

# TOYOTA SEQUOIA

## 2015 PRE-DELIVERY SERVICE CHECK SHEET

August 2014

BEFORE INSPECTION	OK	Adjust/Repair
01 Install Short Pin (see page 2)	<input type="checkbox"/>	<input type="checkbox"/>

FUNCTIONAL OPERATION		
<i>Apply parking brake and cycle ignition "IG-ON"; place gear selector in reverse; turn on lights and rear defogger. Unlock doors; release fuel door.</i>		
01 Check dome, courtesy, map, and sun visor lights*	<input type="checkbox"/>	<input type="checkbox"/>
02 Check warning/indicator lights, gauges, and horn	<input type="checkbox"/>	<input type="checkbox"/>
03 Check windshield wipers and washers	<input type="checkbox"/>	<input type="checkbox"/>
04 Check headlights, instrument lights, turn signals, emergency flashers, and brake lights	<input type="checkbox"/>	<input type="checkbox"/>
05 Check inside/outside rear view mirror operation/adjustment	<input type="checkbox"/>	<input type="checkbox"/>
06 Check cigarette lighter and power outlets*	<input type="checkbox"/>	<input type="checkbox"/>
07 Check audio/navigation*/backup camera* system and set clock	<input type="checkbox"/>	<input type="checkbox"/>
08 Install shift-lock override button cover	<input type="checkbox"/>	<input type="checkbox"/>
09 Check sliding roof*	<input type="checkbox"/>	<input type="checkbox"/>
10 Check Rear Seat Entertainment system operation*	<input type="checkbox"/>	<input type="checkbox"/>
11 Check Parking Assist system*	<input type="checkbox"/>	<input type="checkbox"/>

WALKAROUND INSPECTION		
<i>Start at left front door. Check window and door lock operation (from master power switch, if equipped). Continue around vehicle in a counterclockwise direction checking each door and window operation, child door locks, seat belts, interior condition, all lights, luggage compartment contents. Finish by checking headlight aim and continue into UNDER HOOD checks.</i>		
01 Check Smart Key System*	<input type="checkbox"/>	<input type="checkbox"/>
02 Check door and door lock operation, including each wireless remote control/theft deterrent system*	<input type="checkbox"/>	<input type="checkbox"/>
03 Check window operation	<input type="checkbox"/>	<input type="checkbox"/>
04 Check that engine starts with all keys	<input type="checkbox"/>	<input type="checkbox"/>
05 Check that child safety door locks are in normal (unlocked) position*	<input type="checkbox"/>	<input type="checkbox"/>
06 Check seats and seat belt operation	<input type="checkbox"/>	<input type="checkbox"/>
07 Check rear defogger*/rear view mirror defogger*	<input type="checkbox"/>	<input type="checkbox"/>
08 Check side marker, tail, backup, and license plate lights	<input type="checkbox"/>	<input type="checkbox"/>
09 Check luggage compartment light* and trim appearance	<input type="checkbox"/>	<input type="checkbox"/>
10 Check jack and tool installation	<input type="checkbox"/>	<input type="checkbox"/>
11 Check headlight aim	<input type="checkbox"/>	<input type="checkbox"/>

UNDER HOOD		
01 Check engine oil level	<input type="checkbox"/>	<input type="checkbox"/>
02 Check brake and power steering* fluid levels	<input type="checkbox"/>	<input type="checkbox"/>
03 Check engine coolant level	<input type="checkbox"/>	<input type="checkbox"/>
04 Check windshield washer fluid level	<input type="checkbox"/>	<input type="checkbox"/>
05 Check battery state-of-charge using Digital Battery System Analyzer (SOC Reading: _____%)	<input type="checkbox"/>	<input type="checkbox"/>
06 Inspect for fuel, oil, coolant, and other fluid leaks	<input type="checkbox"/>	<input type="checkbox"/>

\* Inspect or install when equipped/required.

UNDER VEHICLE (ON HOIST)	OK	Adjust/Repair
01 Remove disc brake anti-rust covers/anti-corrosion wheel film	<input type="checkbox"/>	<input type="checkbox"/>
02 Inspect tires for defects/damage	<input type="checkbox"/>	<input type="checkbox"/>
03 Initialize Tire Pressure Warning System (TPWS) (see page 2)	<input type="checkbox"/>	<input type="checkbox"/>
04 Install wheel covers/caps/spare tire wheel covers*	<input type="checkbox"/>	<input type="checkbox"/>
05 Inspect for fuel, oil, coolant, and other fluid leaks	<input type="checkbox"/>	<input type="checkbox"/>
06 Inspect under the vehicle for damage, rust, etc.	<input type="checkbox"/>	<input type="checkbox"/>
07 Visually check bolts and nuts on chassis and powertrain for looseness	<input type="checkbox"/>	<input type="checkbox"/>
08 Install rubber body plugs (stored in glove box or center console)*	<input type="checkbox"/>	<input type="checkbox"/>

ROAD TEST	
<i>A complete road test helps assure customer satisfaction. Drive vehicle over a variety of road surfaces and driving conditions. Check for unusual noise and driving performance.</i>	
Enter Odometer Reading	
Reading Before Test: _____	Reading After Test: _____

01 Check cold engine operation	<input type="checkbox"/>	<input type="checkbox"/>
02 Check engine operation during warm-up	<input type="checkbox"/>	<input type="checkbox"/>
03 Check engine at normal operating temperature	<input type="checkbox"/>	<input type="checkbox"/>
04 Check automatic transmission operation	<input type="checkbox"/>	<input type="checkbox"/>
05 Check brake and parking brake operation	<input type="checkbox"/>	<input type="checkbox"/>
06 Check steering operation and off-center/vehicle pull/flutter	<input type="checkbox"/>	<input type="checkbox"/>
07 Inspect for abnormal noise and vibration	<input type="checkbox"/>	<input type="checkbox"/>
08 Inspect for squeaks and rattles	<input type="checkbox"/>	<input type="checkbox"/>
09 Check front and rear* heater and A/C operation	<input type="checkbox"/>	<input type="checkbox"/>
10 Check cruise control operation	<input type="checkbox"/>	<input type="checkbox"/>
11 Check Blind Spot Monitor system*	<input type="checkbox"/>	<input type="checkbox"/>
12 Check front seat heater/ventilation operation*	<input type="checkbox"/>	<input type="checkbox"/>
13 Set/calibrate compass* (see page 2)	<input type="checkbox"/>	<input type="checkbox"/>
14 Check rear height control air suspension*	<input type="checkbox"/>	<input type="checkbox"/>

FINAL INSPECTION AND CLEANING		
01 Remove interior protective covers, unnecessary labels, tags, etc. (Remove just before delivery to customer)	<input type="checkbox"/>	<input type="checkbox"/>
02 Visually inspect all interior parts for installation, damage, fit, dirt, etc.	<input type="checkbox"/>	<input type="checkbox"/>
03 Verify floor mat application and install using retaining clips*	<input type="checkbox"/>	<input type="checkbox"/>
04 Remove Rappard™ and clear protective bumper film*	<input type="checkbox"/>	<input type="checkbox"/>
05 Wash and clean vehicle	<input type="checkbox"/>	<input type="checkbox"/>
06 Inspect paint finish for scratches, chips, rust, dents, damage, etc.	<input type="checkbox"/>	<input type="checkbox"/>
07 Inspect exterior body parts for proper installation, damage, rust, etc.	<input type="checkbox"/>	<input type="checkbox"/>
08 Place oil change sticker on inside of windshield, top left corner	<input type="checkbox"/>	<input type="checkbox"/>
09 Place Owner's Guide and first aid kit portfolio* in glove box	<input type="checkbox"/>	<input type="checkbox"/>
10 Perform Techstream Health Check	<input type="checkbox"/>	<input type="checkbox"/>
11 Install front license plate and mounting bracket* (see page 2)	<input type="checkbox"/>	<input type="checkbox"/>

Completion and retention of this form is required to comply with Toyota's Warranty Policy.

TECHNICIAN'S SIGNATURE _____		SERVICE MANAGER'S SIGNATURE _____	
NAME (PLEASE PRINT) _____		NAME (PLEASE PRINT) _____	
Date	Dealer Name	Dealer Code	Vehicle Identification Number (Sticker)

**We hereby certify that all items on this form have been checked and corrected for proper operation as required.**

## SHORT PIN INSTALLATION

To minimize battery discharge the Short Pin has been removed and is stored in the engine compartment Relay Block. Install the Short Pin.

### NOTE

If the vehicle is stored in the dealership for a long period of time after PDS, disconnect the negative (-) battery terminal to prevent battery discharge. Refer to Service Bulletin No. PG001-06, "Battery Maintenance for In-Stock Vehicles & Pre-Delivery," for battery maintenance information.

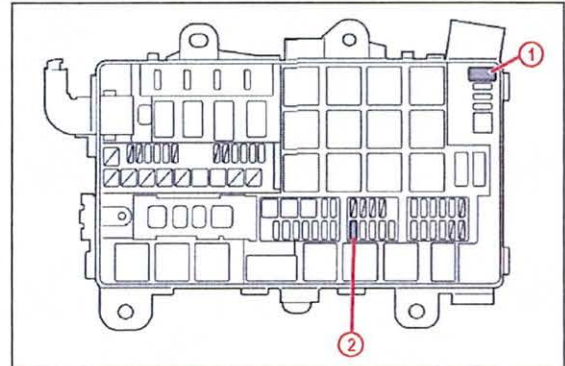

1 Storage Location 2 Installation Location

## TIRE PRESSURE WARNING SYSTEM (TPWS) INITIALIZATION

Refer to the Repair Manual for the Initialization procedure. Please note the spare tire does not have a TPWS sensor.

### NOTE

To adjust tire pressure correctly when outside temperature is significantly colder or warmer than shop temperature, perform a Health Check using Techstream and select the "Compensation Tire Pressure" checkbox. The compensation pressures will be displayed on the Health Check results screen. Adjust the tire pressure when the tires are cold.

## COMPASS CALIBRATION

Refer to the Repair Manual for the Calibration procedure for vehicles equipped with a compass in the rear view mirror.

### NOTE

- Do NOT perform calibration of the compass in a place where the Earth's magnetic field is subject to interference (underground parking, under a steel tower, between buildings, roof parking, near a railroad crossing, near a large vehicle, etc.).
- During calibration, do NOT operate electric systems (moon roof, power windows, etc.) as they may interfere with the calibration.

## FRONT LICENSE PLATE AND MOUNTING BRACKET INSTALLATION\*

The bracket and 6 mounting screws are placed in a vinyl bag located on the right front passenger's side floor.

### Installation Procedure

1. Attach the license plate bracket by snapping the clips on the top of the bracket onto the lower lip of the air intake opening on the bumper.
2. Align the 4 mounting holes in the bracket with the 4 dimples in the bumper.
3. Screw two 20 mm (0.787 in.) self-tapping mounting screws (A) into the top holes on the bumper and then screw the two 30 mm (1.81 in.) self tapping screws (B) into the bottom holes.
4. Align the mounting holes in the license plate with the corresponding holes in the bracket. Using the 2 remaining 20 mm (0.787 in.) self-tapping screws (A), mount the license plate directly to the bracket assembly.

### NOTICE

- Do NOT pre-drill holes into the bumper.
- Do NOT overtighten the self-tapping screws.

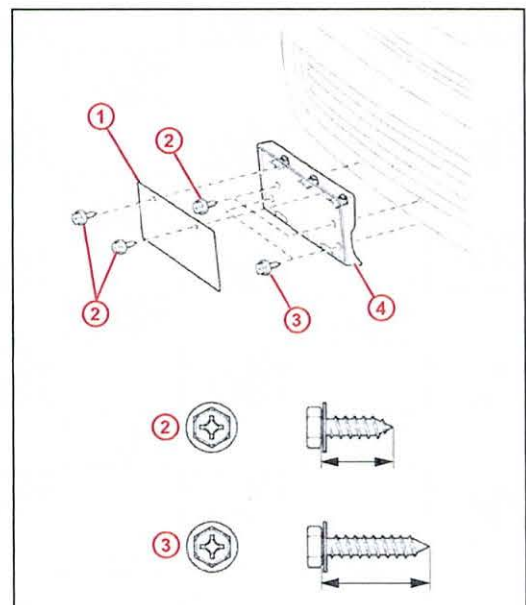

1 License Plate 2 Screw A: 20 mm (0.787 in.) 3 Screw B: 30 mm (1.81 in.) 4 Front License Plate Mounting Bracket