



Innovation that excites

NISSAN BULLETIN

Storage Box Dealer Inventory Service Action

Reference: PC423
Date: March 02, 2016

Attention: Dealer Principal, Sales, Service & Parts Managers

Affected Models/Years:	Affected Population:	Dealer Inventory:	SERVICE COMM Activation date:
MY2016 Titan XD	NA	247	March 1, 2016

*******Dealer Announcement*******

Nissan has identified a small number of vehicles in dealer inventory that should be equipped with storage boxes, but were shipped without the storage boxes installed. **247** specific MY2016 Titan XD vehicles identified in SERVICE COMM will require storage box installation. These vehicles are currently in dealer inventory, assigned and in transit to the dealer, or retailed.

IMPORTANT: Dealers should not trade any affected vehicles in dealer inventory subject to this service action until the storage boxes have been installed.

*******What Dealers Should Do*******

PLEASE FOLLOW THE ATTACHED REPAIR INSTRUCTIONS:

1. Verify if vehicles currently in dealer inventory are affected by this service action using Service Comm **I.D. PC423**.
2. Use the attached instructions to install the storage boxes.
3. The service department should submit a warranty claim **for labor only** and then release the vehicle for sale.

NOTE: Dealers will not be billed again for parts shipped to their dealer as the cost was included in the original vehicle invoice.

******* Claims Information *******

CAMPAIGN (CM) I.D.	CAMPAIGN OP CODE	DESCRIPTION	FLAT RATE TIME
PC423	PC4230	Install storage box (Dual Wall Bed Liner) to Left and Right Side	0.8 hrs

******* Parts Information *******

Parts will be shipped directly to affected dealers by a third party. Parts will not be visible on a dealer's daily parts allocation report. **Please be aware that each box of parts will also include 4 Utili-track® cleats.** Each box should include the following information on the label:

- Dealer Name
- Dealer Number
- VIN (for affected vehicle)
- Part Number

Parts will begin shipping via Pegasus Logistics over the next few days. Nissan expects shipments to be completed by March 18, 2016.

If a dealer receives parts for a vehicle they have traded, please notify the dealer in possession of the vehicle of this action and provide them the parts provided without charge.

******* Dealer Responsibility *******

It is the dealer's responsibility to check Service Comm using the appropriate campaign I.D for the inspection status on each affected vehicle currently in inventory. Nissan requests dealers to perform this repair on vehicles in inventory prior to being retailed to ensure customer satisfaction.

NISSAN NORTH AMERICA, INC.

Aftersales DIVISION

Frequently Asked Questions (FAQ):

Q. Is this a safety recall?

A. No. This is a dealer service action.

Q. What is the reason for this dealer action?

A. Certain Titan XD vehicles were intended to have the storage boxes included, but were released to dealers without the accessory installed. The storage boxes are listed on the Monroney label for these affected units. Dealers were billed for the cost of the storage boxes as part of the original vehicle invoice price.

Q. What is the possible effect of the condition?

A. Vehicle content does not match Monroney Label.

Q. What will be the corrective action?

A. Nissan dealers will install storage boxes on the affected vehicles identified in SERVICE COMM.

Q. How long will the corrective action take?

A. This service, which is conducted at no charge to you for parts and labor, should take approximately 1 hour to complete.

Q. Are parts readily available?

A. Parts will be shipped directly to affected dealers over the next few weeks. **Dealers will not be billed again for parts shipped to their dealer as the cost was included in the original vehicle invoice.** However, if a dealer receives parts for a vehicle they have traded, please notify the dealer in possession of the vehicle of this action and provide them the parts provided without charge.

Q. An affected vehicle has been retailed, should I contact the customer?

A. We are currently determining how to address owners of any affected retailed vehicles. If parts are available and an affected customer contacts your dealer about this issue or comes in for service, dealers may install the storage box at no charge to the customer. Dealers can use the parts provided for their vehicle and file a warranty claim for PC423.

Q. Who can I contact with further questions, parts issues, etc.?

A. Please send an email with your concerns to campaignannouncements@nissan-usa.com. Please be sure to provide a contact name and phone number along with your questions or concerns.



GENUINE PARTS

INSTALLATION INSTRUCTIONS

DESCRIPTION:	Dual Wall Bedliner
APPLICATION:	Titan
PART NUMBER:	999T1 W3770

KIT CONTENTS:

Item	Qty.	Part Description	Service Part Number
A	1	Bin Assembly	n/a
B	4	M8 Rivnut	n/a
C	4	M8 Washer	n/a
D	4	M8 Spacer	n/a
E	4	M8 X 33 Shldr Bolt	n/a
F	4	M6 Rivnut	n/a
G	4	M6 Washer	n/a
H	4	M6 X 25 Shldr Bolt	n/a
I	1	Installation Instruction Replacement Template	n/a

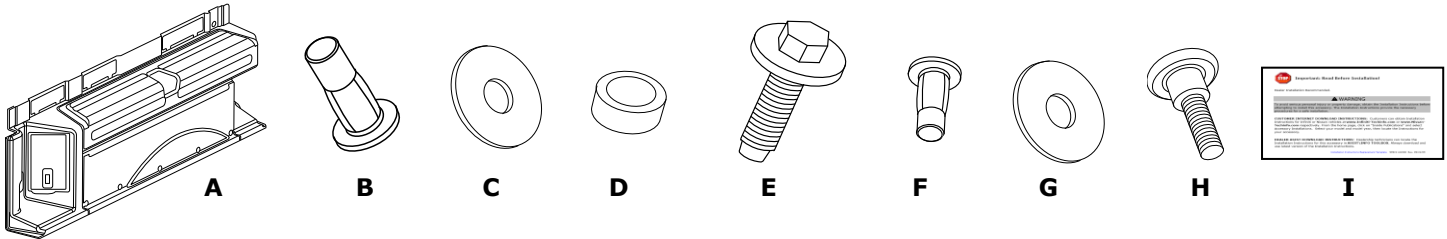

TOOLS REQUIRED:

- Driver Nut with Variable Torque Setting
- Rivnut Installation Tool
- 10MM Socket
- T30 Torx Driver
- Extension 6"

PRE-INSTALLATION WARNINGS, CAUTIONS, CRITICAL STEPS, and NOTES:

- Dealer Installation Recommended. Instructions may refer to Service Manual.

⚠ WARNING

- Static electricity can cause an explosion of flammable liquid vapor or gas in any vehicle or trailer. Do not use bedliner or tailgate cover as a surface for filling a container with flammable liquid.

⚠ CAUTION

- Installation of the bedliner requires two people. Do not attempt to install the bedliner by yourself.
- For proper installation, the sheet metal truck box and bedliner must be at room temperature (65-80 F) at the time of installation.

INSTALLATION PROCEDURE: (continue)

- 1) Apply parking brake.

⚠ CAUTION

- Read entire installation procedure prior to installing new bedliner in order to become familiar with process.

Driver side shown. Repeat steps 3 through 7 for passenger side installation.

- 2) Before installing dual wall bedliner, thoroughly clean bed. (Figure 1).

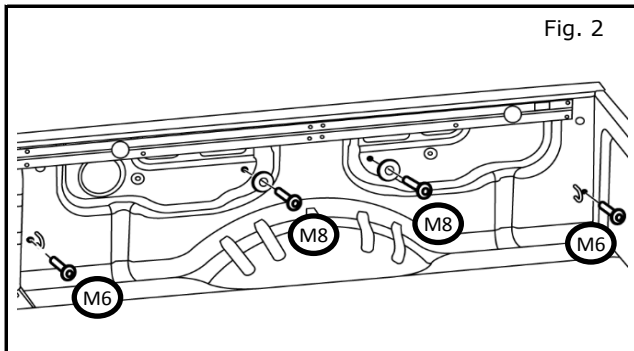
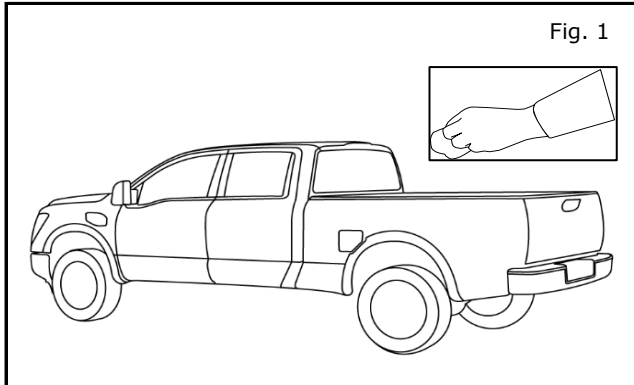

- 3) Install M8 and M6 rivnuts as follows:
 - a) Install M8 rivnuts in locations shown in Figure 2. Using Rivnut installation tool install M8 rivnut using washer under head Figure 3.
 - b) Install M6 rivnuts in locations shown in Figure 2 using installation tool. Washers are not required for M6 rivnut installation.

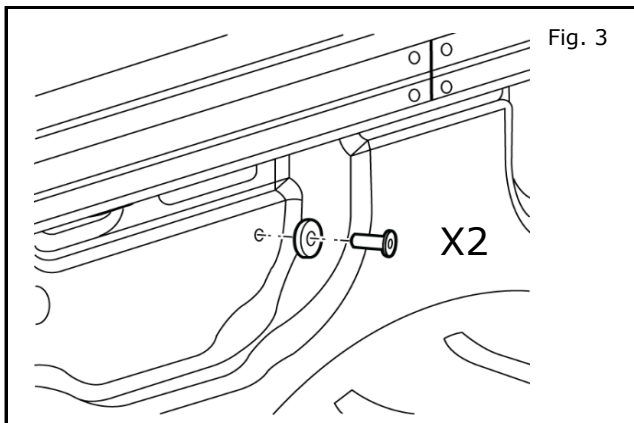

INSTALLATION PROCEDURE: (continue)

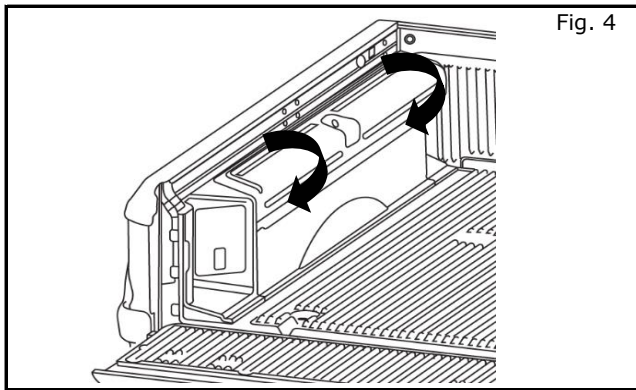

- 4) Position bin assembly near sidewall of truck box (Figure 4). Angle top of bin assembly so upper tabs are positioned behind Utili-trac trail.

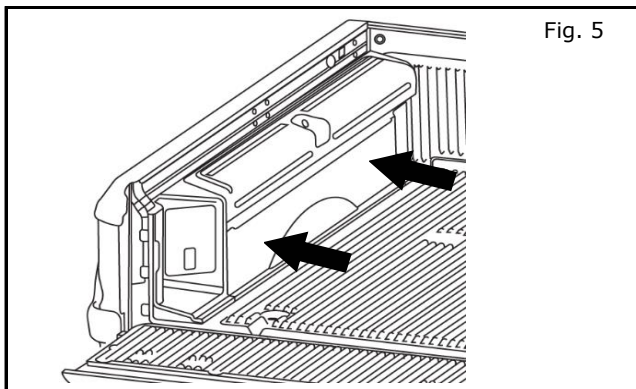

- 5) Push bin assembly tight to side of wall of truck box and align fastener holes with M8 and M6 rivnuts. Ensure fixed tie down loops slide through assembly cutouts. (Figures 5 and 6).

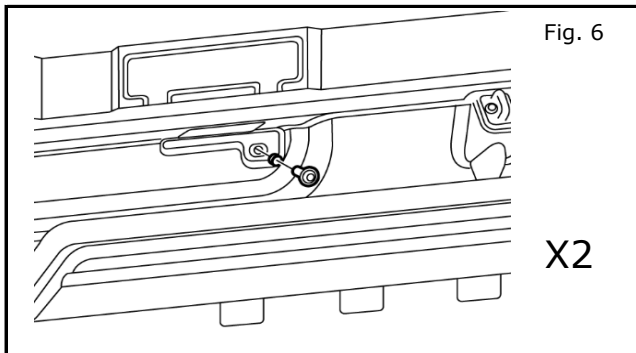

- 6) Open bin assembly lid and install M8 spacer and M8X33 bolt. Install in (2) locations (Figure 7). Tighten screws to 10Nm.

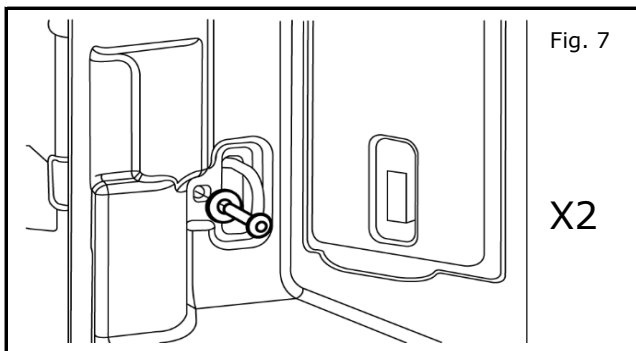

- 7) At front and rear tie down holes, install M6 x 25 shldr bolt and washer (2) locations. Tighten bolts to 5Nm.

INSTALLATION PROCEDURE: (continue)

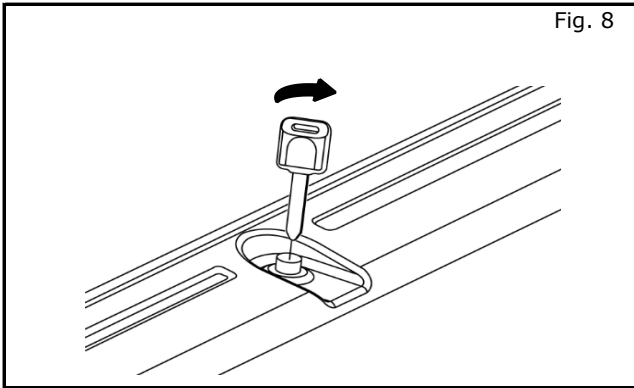

- 8) Code accessory key to bin lock.
 - a) Insert accessory key into bin lock.
 - b) Turn accessory key clockwise to code key.
 - c) Repeat for opposite side.

NOTE: Key may need to be wiggled back and forth during coding process.