

QUALITY ACTION



CAMPAIGN BULLETIN

2G Telematics Hardware Replacement Client Satisfaction Initiative

Reference: PC451, PC452, PC454
Date: September 2, 2016

Attention: Retailer Principal, Sales, Parts and Service Managers

Affected Models/Years:	Affected Population:	Retailer Inventory:	SERVICE COMM Activation date:	Stop Sale In Effect
2013 M37, M56, JX35, QX56	NA	NA	September 2, 2016	NO
2014-15 & certain 2016 Q70, QX60, & QX80				

***** Client Satisfaction Initiative Summary *****

On February 26th, 2016 Infiniti announced that it was sending a reminder notification to clients affected by AT&T's planned discontinuation of the 2G cellular network. In June 2016, Infiniti communicated instructions to retailers to update new vehicles in their inventory with 3G compatible telematics control units.

At this time, Infiniti is beginning the process of making 3G compatible hardware available to owners of affected vehicles as identified above. This upgrade may require an owner make a co-payment in order to receive the 3G hardware update. Please refer to the chart provided on page 2 to determine if an owner co-pay is required. This client satisfaction initiative includes both the hardware upgrade and a complimentary one-year subscription to Infiniti Connection Plus telematics service; this does not apply to PC454 (see page 2 for details).

Note: Vehicle eligibility will be viewed on the second page of Service Comm (except PC454). This activity is not displayed on the main page of Service Comm because it is optional for clients to participate.

```
S E R V I C E - C O M M
08/31/16 14:34:38      SERVICE BULLETINS      CICSWB06
PRIMARY DATA          NMC MODEL: 94413      VIN: JN1AY1AR5DM590133
13 M56X AWD SEDAN     AUTOMATIC EMISSIONS CERTIFICATION: 50 STAT
MANUFACTURE DATE: 01/30/13  PLANT: TOCHIGI
-----
---REF---  ---POSTED---  -----DESCRIPTION-----
PC451      2016-10-10  2G TELEMATICS UPDATE TO 3G COMPATIBLE CONTROL UNITS
APPLIED REMARKS: THIS UPDATE WILL INCLUDE A 1 YEAR SUBSCRIPTION TO
                  INFINITI CONNECTED PLUS SERVICES AND WILL REQUIRE
                  A $299.00 CO-PAY FROM THE CLIENT
```

```
S E R V I C E - C O M M
08/31/16 14:24:34      SERVICE BULLETINS      CICSWB06
PRIMARY DATA          NMC MODEL: 84216      VIN:
16 QX60 3.5 AWD       AUTOMATIC EMISSIONS CERTIFICATION: 50 STAT
MANUFACTURE DATE: 05/17/16  PLANT: SMYRNA, TN.
-----
---REF---  ---POSTED---  -----DESCRIPTION-----
PC452      2016-10-10  2G TELEMATICS UPDATE TO 3G COMPATIBLE CONTROL UNITS
APPLIED REMARKS: THIS UPDATE WILL INCLUDE A 1 YEAR SUBSCRIPTION TO
                  INFINITI CONNECTED PLUS SERVICES AND WILL REQUIRE
                  A $149.00 CO-PAY FROM THE CLIENT
```

******* What Retailers Should Do *******

1. Verify if vehicles are affected by this client satisfaction initiative using Service Comm I.D. **PC451, PC452**, which can be found on the second page, or **PC454** on the main page.
2. Retailers should ensure clients are informed of this 3G upgrade option when bringing their vehicle in for service **and that clients understand a co-pay may be involved.**
3. Retailers must obtain client approval in advance of the upgrade being performed. If client approves, update the vehicle using the procedure included with this announcement.

MODEL	MODEL YEAR	CO-PAY AMOUNT	PNC
M37, M56, JX35, QX56	2013	\$299	PC451
Q70, QX60, QX80	2014		
Q70, QX60, QX80	2015-2016*	\$149	PC452
		\$0	PC454**
Q50 is not available at this time. Refer to Q&A for additional information			

***Only certain 2016 model year vehicles are affected**

**** PC454 applies to new vehicle inventory service action released June 29th 2016**

Please refer to the 3rd bullet (•) below for additional details

- If a client elects to have a 3G compatible Telematics Control Unit installed, the retailer is responsible for collecting the co-pay from the client
- Upon completion of the installation of the 3G hardware, retailers will file a warranty claim for the parts and labor
 - Retailers will initially be paid for the full amount of the claim
 - Infiniti will subsequently debit the retailers Non Vehicle Account for the amount of the co-pay they collected from the client
 - Retailers will be able to view debits on their monthly Retailer Claims Status Reports
- PC454 applies to vehicles that were subject to the retailer service action, but were retailed before the update was performed. PC454 will display on the main page of Service Comm
 - These vehicles will not require a client co-pay nor will retailers receive a claims debit. These owners will only receive a 6-month Infiniti Connection Plus complimentary trial upon installation of the 3G hardware; they will not receive the complimentary one-year subscription to Infiniti Connection Plus telematics services included on PC451 & PC452.
 - Retailers should still acquire client approval to install the 3G compatible Telematics Control Unit prior to performing the update
 - Retailers should continue to perform PC454 on applicable vehicles in their inventory

4. For PC451 and PC452, clients must confirm their participation in the complimentary one-year Infiniti Connection Plus subscription on the Infiniti Owner Portal after installation of the 3G compatible hardware. Please provide clients with a copy of the login instructions provided with this announcement. If possible, retailers should assist clients with this process.

******* Release Schedule *******

Parts	<ul style="list-style-type: none"> • Infiniti will provide an initial supply of parts to all retailers <ul style="list-style-type: none"> ○ Parts are expected to begin arriving on September 6th, 2016 ○ Refer to the automatic parts distribution plan included with this announcement • 283B0-3JA5A is the part number being used for this activity <ul style="list-style-type: none"> ○ This part is not restricted ○ Retailers should not order parts until after they have received their automatic shipment
Repair	<ul style="list-style-type: none"> • There is no TSB for this upgrade • Use the procedure included with this announcement after the FAQ
Owner Notification	Infiniti expects to begin notifying owners of potentially affected vehicles in September, 2016 via U.S. Mail.

******* Retailer's Responsibility *******

It is the retailer's responsibility to check SERVICE COMM using the appropriate Campaign I.D. for the status on each vehicle falling within the range of this client satisfaction initiative which for any reason enters the service department. If a VIN subject to this client satisfaction activity was part of a retailer trade, the letter associated with that VIN should be forwarded to the appropriate retailer for upgrade completion.

Frequently Asked Questions (FAQ):

Q. What is the reason for this client satisfaction activity?

A. AT&T will discontinue its 2G cellular network coverage on December 31, 2016. Like all cellular-equipped devices designed to connect to the 2G cellular network, Infiniti models with a 2G-compatible telematics control unit (TCU) will be unable to use or receive services from that device after December 31, 2016. Without an upgrade to the TCU, Infiniti Connection™ features will not be available after that time and may be impacted prior to that date depending upon AT&T's proprietary decisions regarding discontinuing 2G network coverage. Also, AT&T stopped accepting new enrollments on the 2G network on July 1, 2016. If an affected vehicle has not had a hardware upgrade and was not enrolled in Infiniti Connection™ before June 30, 2016, then it will not have access to the available Infiniti Connection™ features, including Emergency Calling and Automatic Collision Notification, until the upgraded hardware is installed.

Q: What is 2G cellular network access?

A: 2G refers to "2nd Generation" digital cellular telephone technology; it is the name of a specific network that mobile telephone equipment uses to provide connectivity.

Q. Which vehicles have 2G compatible TCUs?

A. The following models equipped with navigation have 2G-compatible TCUs:

- 2013 Infiniti M37/M56, JX35 and QX56
- 2014-15 Infiniti Q50
- 2014-15 and some 2016 Infiniti Q70, QX60 and QX80

Q: What happens if I do not replace the TCU?

A: Once the 2G cellular network is discontinued, the TCU will no longer be able to access the Infiniti Connection™ features, including Emergency Calling and Automatic Collision Notification, without a hardware upgrade. New vehicles sold after June 30, 2016 will not be able to be enrolled in the complimentary trial for Infiniti Connection™ until the hardware has been upgraded to be compatible with the 3G cellular network.

Q: Will the new TCU hardware work with the 4G cellular network?

A: No. The new TCU hardware is designed to connect to the current AT&T 3G cellular network technology.

Q. Why is Infiniti using 3G technology rather than 4G?

A. Infiniti has studied how to integrate newer technology into your vehicle and developed solutions aimed at delivering a hardware update option with the least inconvenience to clients. The 3G network is supported throughout the U.S. by AT&T. However, Infiniti has no control over availability of any cellular network.

Q: How much will the replacement TCU cost?

A. Clients are asked to participate in the cost of the parts and labor to upgrade the TCU. The client co-pay amount varies by model year and is listed in the chart below. Infiniti will cover the balance of the upgrade cost and include a complimentary one-year subscription to Infiniti Connection Plus telematics services (PC451 & PC452 only). PC454 will receive a complimentary 6-month trial to Infiniti Connection Plus telematics services. The Infiniti Connection Plus telematics services subscription retail cost is \$308/year.

MODEL	MODEL YEAR	CO-PAY AMOUNT	PNC
M37, M56, JX35, QX56	2013	\$299	PC451
Q70, QX60, QX80	2014		
Q70, QX60, QX80	2015-2016*	\$149	PC452
		\$0	PC454

Q50 is not available at this time. Refer to Q&A for additional information

Q. Why are Q50 vehicles currently excluded from this client satisfaction initiative?

A. Infiniti is still preparing the upgrade specific to the Q50. A separate announcement will be made when Q50 upgrade is available.

Q: A client has a 2G-equipped Infiniti and is enrolled in Infiniti Connection™. Why do they have to pay for a replacement TCU?

A: The discontinuation of the 2G cellular network is outside of Infiniti's control. The Infiniti Connection™ subscription agreement states that clients are responsible for any hardware upgrades due to changes in telecommunication systems. However, Infiniti is including a complimentary one-year subscription to Infiniti Connection Plus telematics service when an owner elects to upgrade to a 3G compatible TCU. A one year subscription to Infiniti Connection Plus telematics service is currently valued at \$308/year, which is more than the owner co-pay for this client satisfaction initiative. The one year subscription will be added to any remaining time currently on an owner's trial enrollment. If the client already has a paid subscription on their 2G equipped vehicle, the current subscription will be cancelled and a pro-rated refund will be sent to the owner after the new 3G compatible TCU upgrade is completed.

Q: Will the SOS button in the vehicle still work?

A: If an owner of an affected vehicle enrolled in an Infiniti Connection service trial or subscription prior to June 30, 2016, then the SOS button in the vehicle will work through the service trial or subscription period as long as the vehicle's telematics hardware is connected to the cellular network. If an owner of an affected vehicle did **not** enroll in an Infiniti Connection™ service trial or subscription prior to July 1, 2016, then the SOS button in the vehicle will not function until the TCU is upgraded.

Q: Will my vehicle's navigation system feature be affected by the discontinuation of the 2G cellular network?

A: No. If your vehicle is equipped with an Infiniti Navigation system, the navigation system is unaffected by the discontinuation of AT&T's 2G cellular network.

Q. What will be the service department action?

A. If an owner elects to upgrade to a 3G compatible TCU and agrees to pay the applicable co-pay, the retailer's service department should install the 3G hardware using the procedure accompanying this announcement.

Q. How long will the upgrade take?

A. The upgrade will typically take under 2 hours to complete.

Q. When will vehicle owners be notified?

A. Infiniti plans to begin notifying owners of potentially affected vehicles in **September, 2016** via U.S. Mail. Owners may contact Infiniti Owner Services at 855-444-7244 to verify if their vehicle is affected by this issue.

Q. Are parts readily available?

A. Yes. Parts will be automatically shipped to retailers and are expected to arrive beginning September 6th, 2016. Retailers can order additional parts as needed once they receive their automatic shipment.

Q. Will a courtesy vehicle be provided while the retailer is servicing the vehicle?

A. Infiniti may provide a courtesy vehicle for the client to use while their vehicle is being serviced. Courtesy vehicles are subject to availability and not guaranteed. Please check with your retailer for availability and further details.

Q. Will I have to take my vehicle back to the selling retailer to have this service performed?

A. No, any authorized Infiniti retailer is able to perform this service.
For Consumer Affairs: Please inform us of the retailer where you would like to have the upgrade completed.

Q. Does this issue affect any other Infiniti (or Nissan) models?

A. Model year 2011-2015 Nissan LEAF vehicles are also affected.

Q. I did not receive a letter. How can I tell if my vehicle is affected?

A. Please provide your vehicle identification number (VIN) to the retailer so that the retailer can check if your vehicle is included in this campaign. Clients may also contact Infiniti Owner Services at 855-444-7244 to verify if their vehicle is affected by this issue.

Retailer Service Questions:

Q. Is it possible to identify if a vehicle has a 2G or 3G TCU without removing the TCU?

- A. For the QX60, Q70, QX80:
To identify if the vehicle has a 2G or a 3G TCU, complete the following steps on the head unit:
1. Press the hard button labeled Setting/Info
 2. Press the "Others" soft button on the center display screen
 3. Press the "Infiniti Connection" soft button
 4. Press "Unit ID information"
 5. If TCUID starts with " 2021-1" it is a 3G device
 6. If TCUID starts with " 2021-0" it is a 2G device

Q. What if the 2G or 3G TCU part is missing the IMEI (International Mobile Equipment Identity) number that is used to identify the TCU?

- A. The IMEI number can be found on the label adhered to the TCU part. If this label is missing or is not legible, you can use the SIM ID/ICCID instead. The SIM ID/ICCID is located on the head unit "Unit ID" screen, you can locate this screen by following the steps in the question above. You will need to locate this number prior to calling the SiriusXM agent to deactivate the 2G TCU and activate the 3G TCU.

Retailers will also need to have the model, model year, sales country (i.e. USA), marketing color name of the vehicle and VIN available

Q. Who can I call with Telematics system specific questions?

- A. Contact the Infiniti Connection / Infiniti InTouch Services call center @ 855-444-7244. The call center is operational between 8AM-12AM EST Monday through Saturday.

Q. Can the 283B0-3JA5A part number be used on all Infiniti models?

- A. The 283B0-3JA5A part number can only be used on:
- 2013 Infiniti M37/M56, JX35 and QX56
 - 2014-2016 Infiniti Q70, QX60 and QX80

Q. May a retailer offer retailer paid goodwill to cover the cost of a client's co-pay for this upgrade?

- A. The retailer is responsible for collecting the copay from an owner electing to upgrade to a 3G compatible TCU and may choose to not collect co-pays as service to their clients. Infiniti will debit a retailers non-vehicle account for each claim submitted when a co-pay applies.

Q. Will Infiniti cover an owner's co-pay using factory goodwill?

- A. No. Factory goodwill will not cover a co-pay for owner's electing to upgrade to a 3G compatible TCU.

Login instructions for the Infiniti Owner portal & installation instructions follow.

- **M37, M56, & Q70 – pages 10 – 21**
- **JX35 & QX60 – pages 22 – 47**
- **QX56 & QX80 – pages 48 – 60**

Infiniti Owner Portal Login and Infiniti Connection Subscription Confirmation Instructions:

Owners must follow these instructions to confirm their participation in the complimentary trial for Infiniti Connection Plus telematics service.

1. Log onto the Infiniti Owner Portal, if not already enrolled, the client will need to create an account and add their vehicle to their personal garage, then click on the **Infiniti Connection** button
2. The client will be directed to the Infiniti Connection web portal where they should click the "**Enroll Now**" button
3. The primary subscriber tab will open and be pre-populated if the client was previously enrolled in Infiniti Connection, otherwise, the client will need to enter their information and click "**Next**"
4. The Package Selection page will appear where the complimentary 12-month Infiniti Connection Plus package information will be pre-populated. No credit card is required to continue, but the client may elect to automatically renew after the complimentary subscription by providing payment information, then click "**Next**"
5. The client will be presented with their selection summary and asked to confirm the Terms & Conditions of participation. This will complete the confirmation and services will be active
6. If the client has not already done so, assist the client in downloading the Infiniti Connection companion app from either the App Store or Google Play
7. For assistance with this process, you and your clients can contact Infiniti Owner Services at 1-855-444-7244



M37, M56, & Q70 Telematics Control Unit Replacement

IMPORTANT: Those steps in **RED** below, under Campaign Overview, **MUST** be performed in the order listed for the new TCU to operate correctly.

Campaign Overview:

1. Turn OFF the original TCU using CONSULT-III plus (C-III plus) (page 2).
2. Save the VIN DATA using C-III plus (page 7).
3. Remove the original TCU from the vehicle (page 8).
4. Deactivate (unregister) the original TCU by calling INFINITI CONNECTION™ Call Center (page 9).
5. Activate (register) the replacement TCU by calling INFINITI CONNECTION™ Call Center (page 9).
6. Install the replacement TCU in the vehicle (page 10).
7. Turn ON the replacement TCU using C-III plus (page 10).
8. Write the VIN DATA using C-III plus (page 10).

SERVICE PROCEDURE

Turn OFF the TCU

1. Connect the C-III plus VI to the vehicle.
2. Set the parking brake.
3. Turn the Ignition ON, but do not start the vehicle.
4. Launch C-III plus on the CONSULT PC.
5. Select **Diagnosis (One System)**.

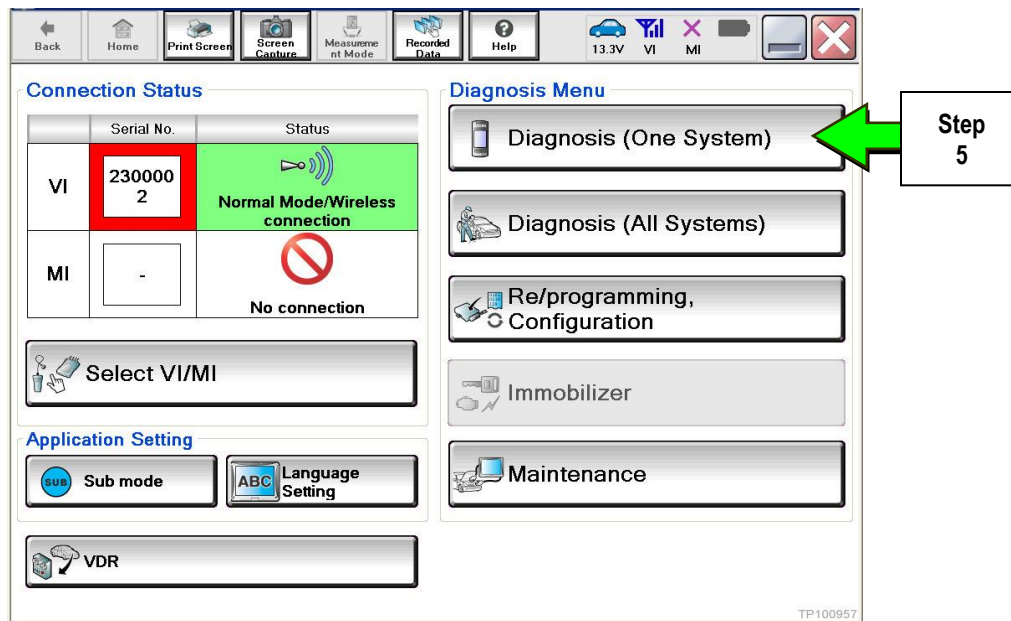

Figure 1

6. Select **TELEMATICS** on page 2 of the “All systems” list.

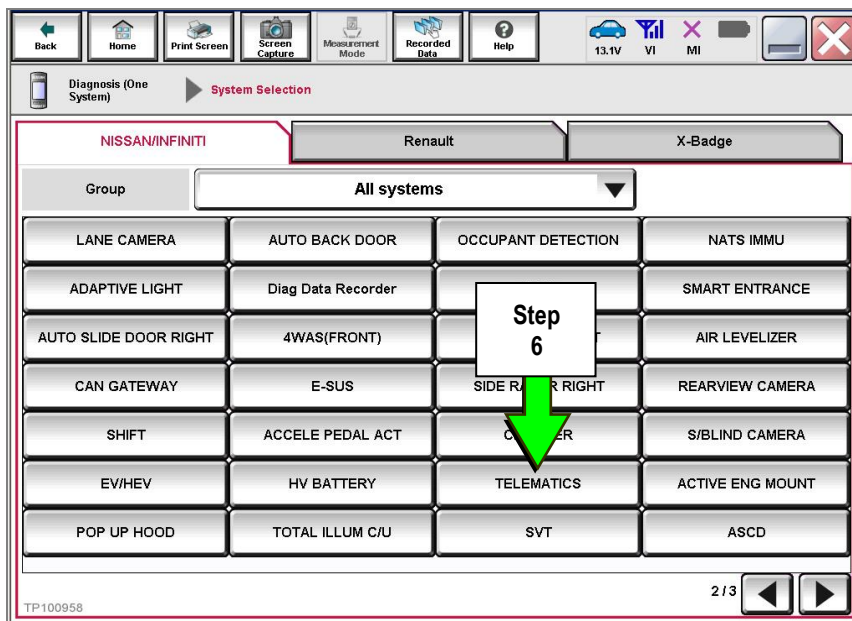

Figure 2

7. Select **Work support**.

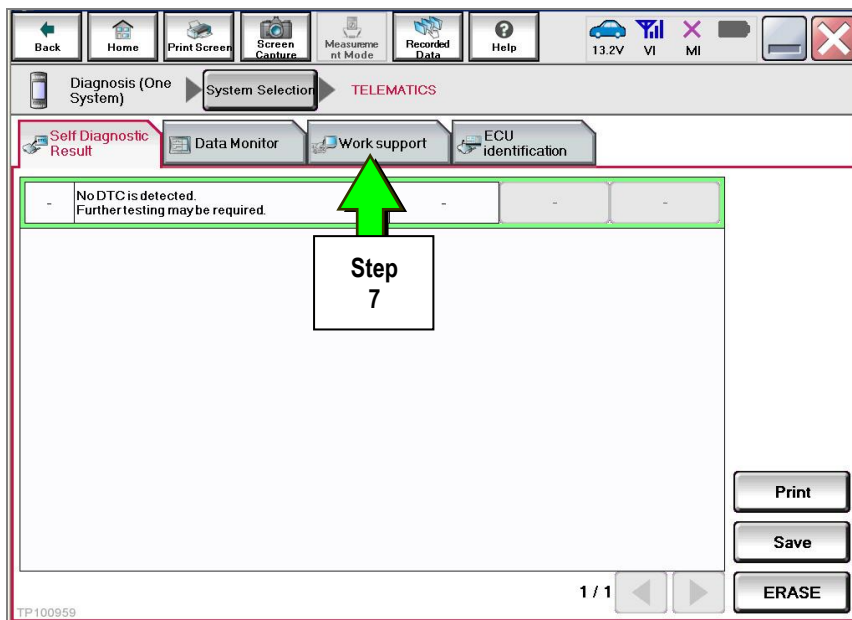

Figure 3

8. Select **TCU ACTIVATE SETTING**.

9. Select **Start**.

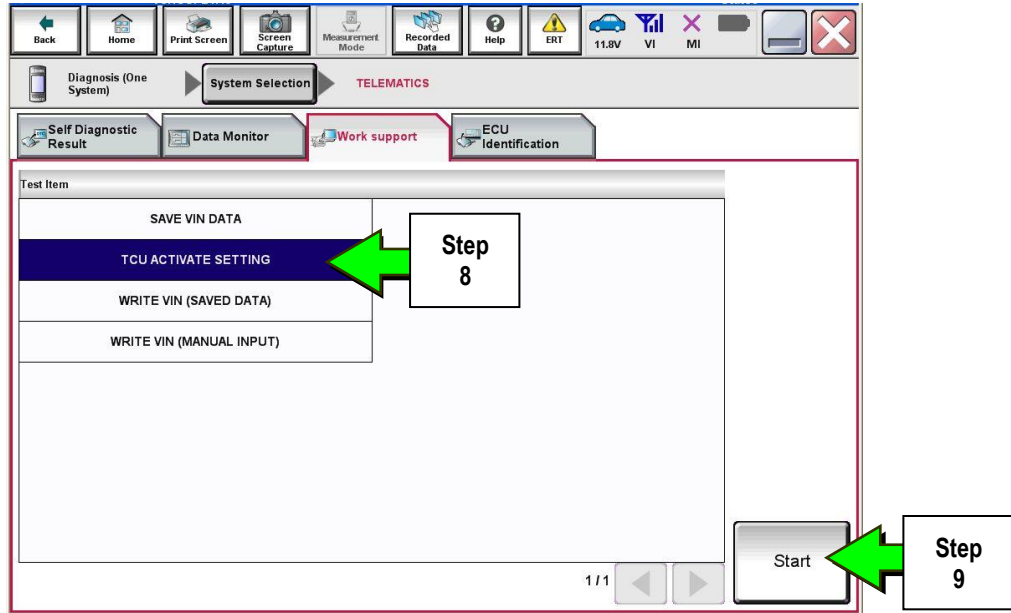

Figure 4

10. Select **Start**.

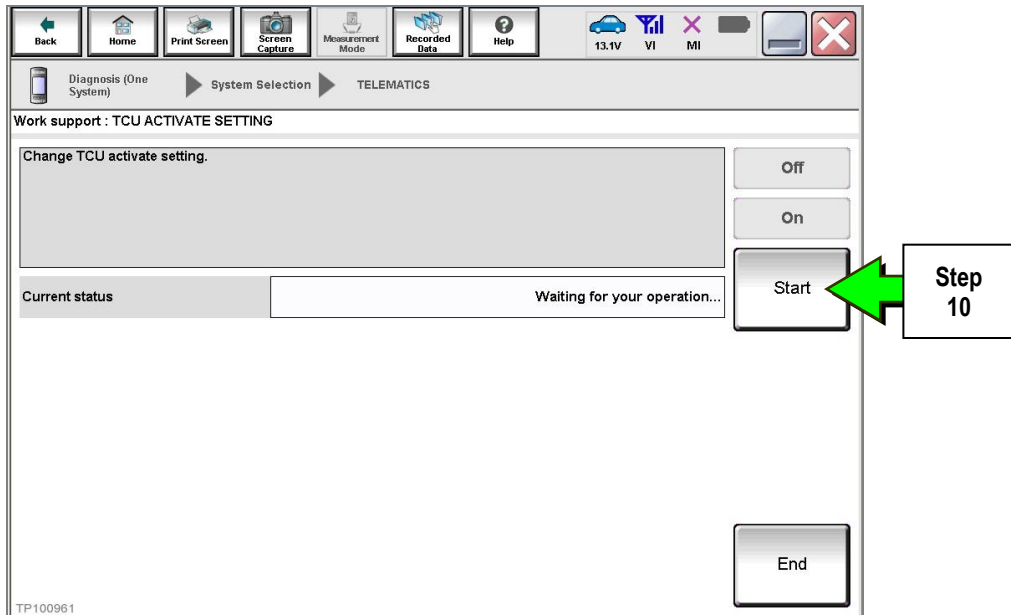

Figure 5

11. Select **Off** to turn OFF the TCU.

12. Select **End**.

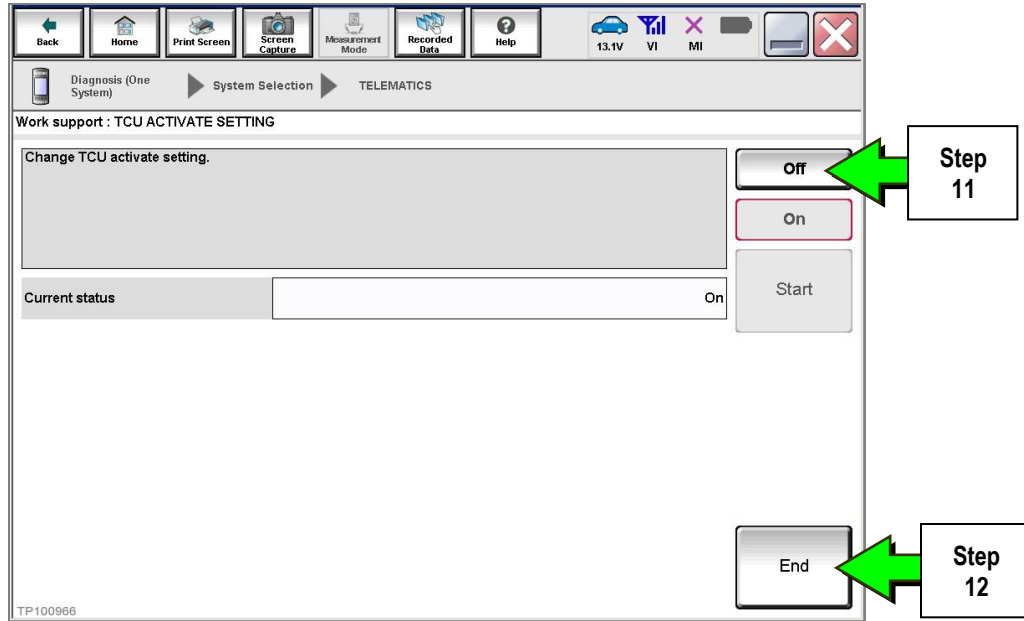

Figure 6

13. Select **Start**.

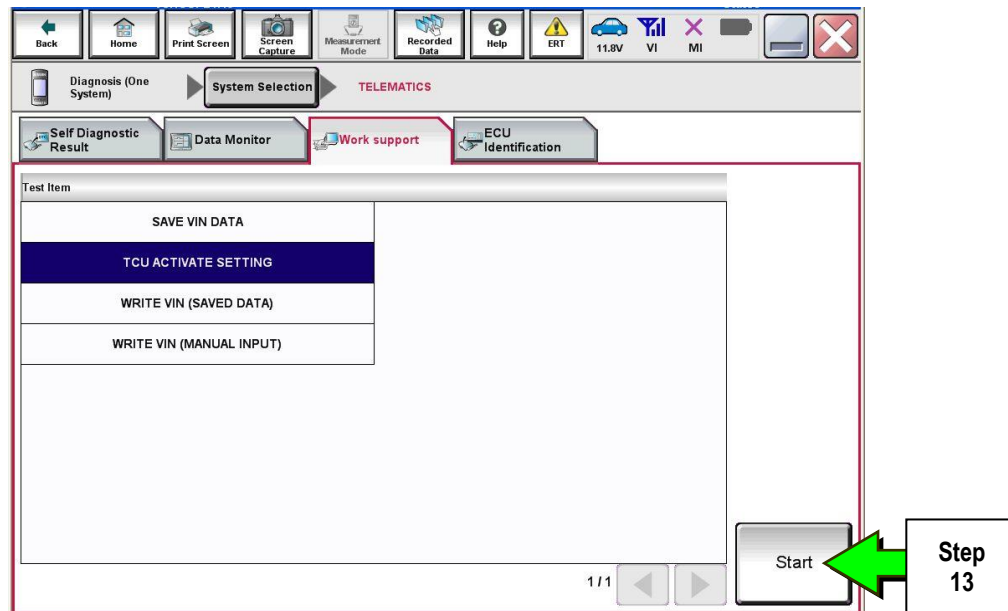

Figure 7

14. Select **Start**.

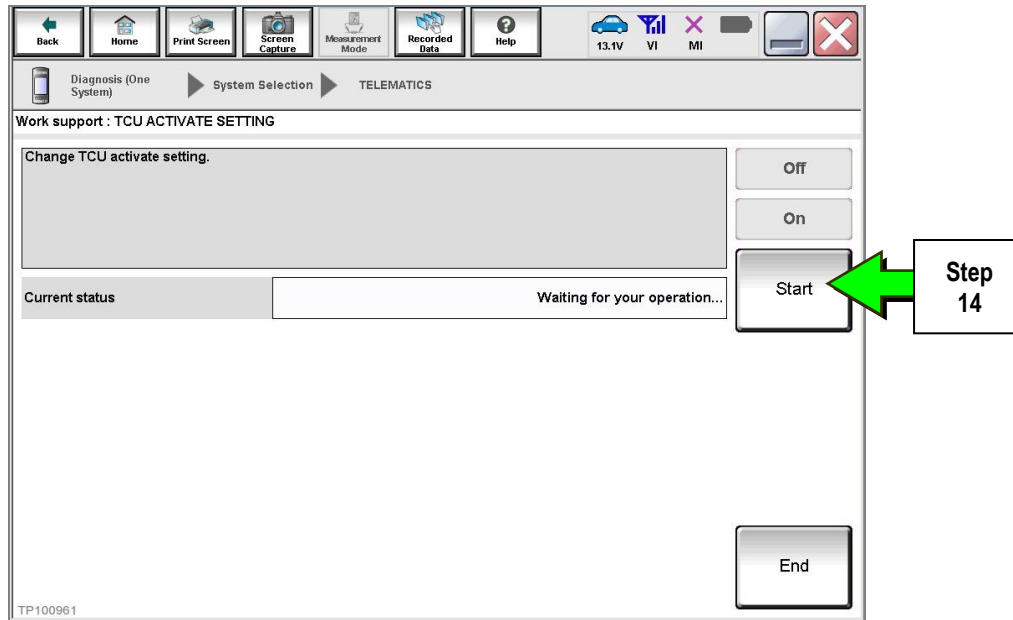

Figure 8

15. Confirm "**Off**" is displayed in the **Current status** field.

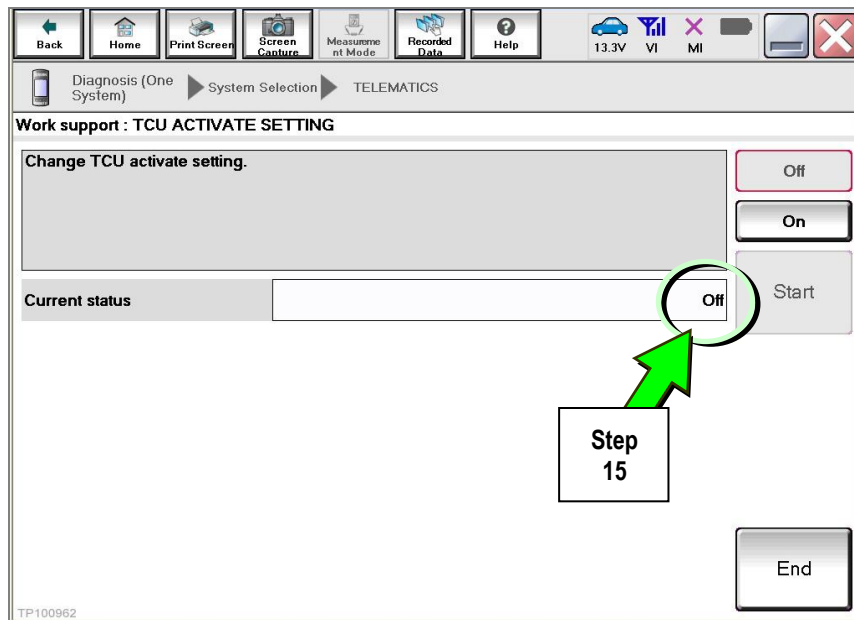

Figure 9

Save VIN Data

1. Select **SAVE VIN DATA**.
2. Select **Start**.

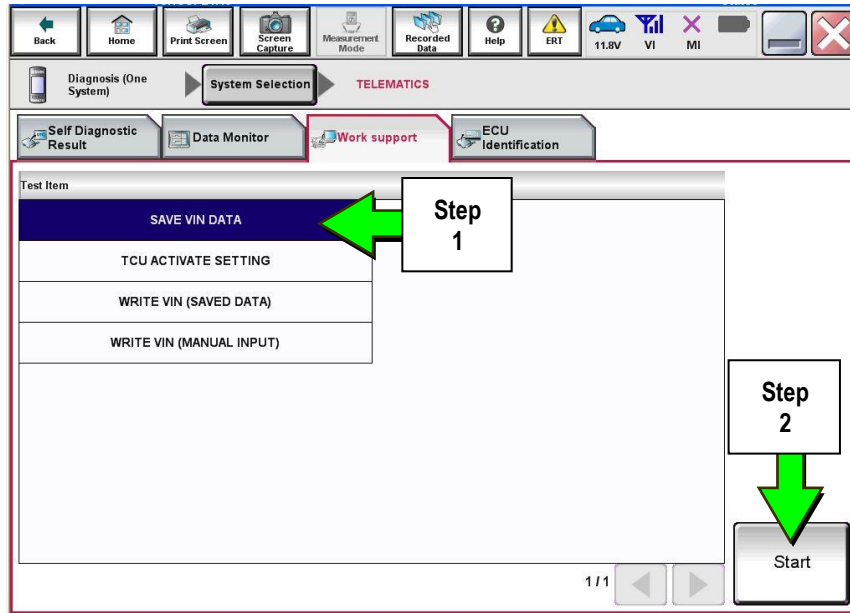

Figure 10

3. Select **Start**.

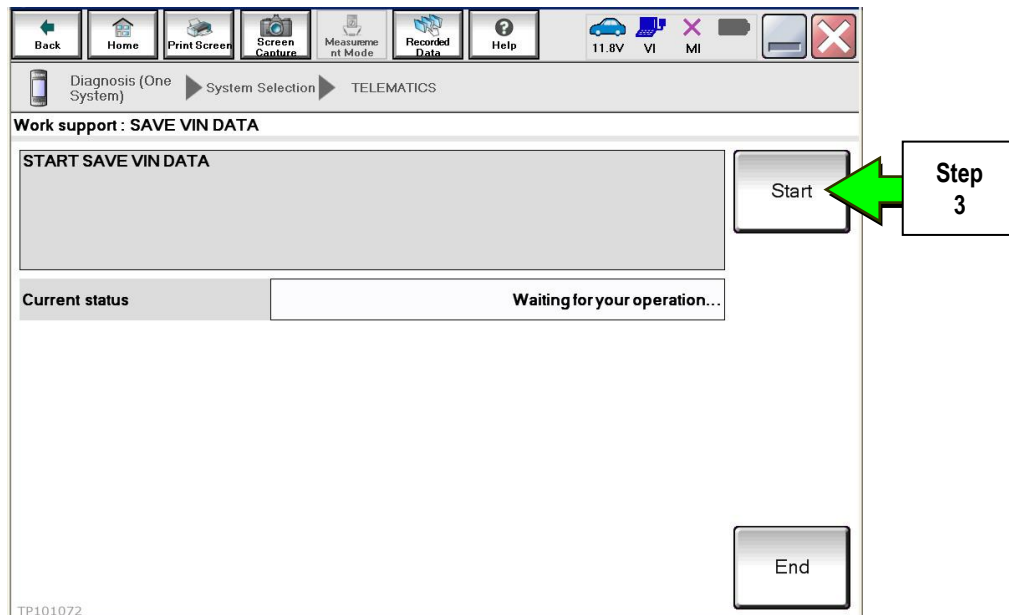

Figure 11

4. Select End.

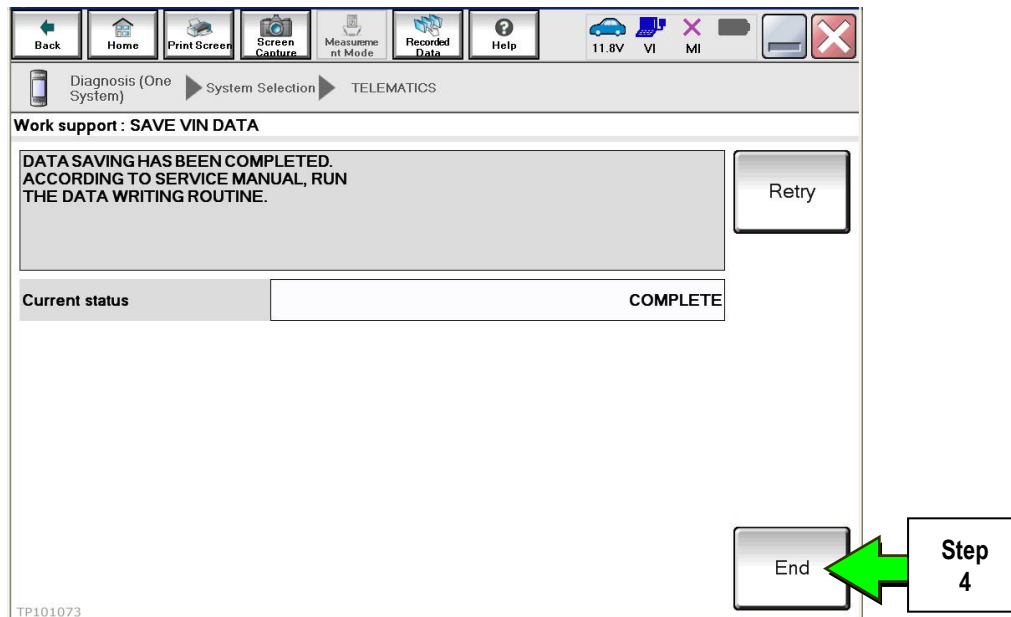

Figure 12

Remove the TCU from the Vehicle.

1. Remove the instrument lower cover.
 - a. Pull downward and disengage fixing pawl and metal clips.
 - b. Pull back instrument lower cover.
 - c. Disconnect foot lamp RH harness connector and TCU harness connector.

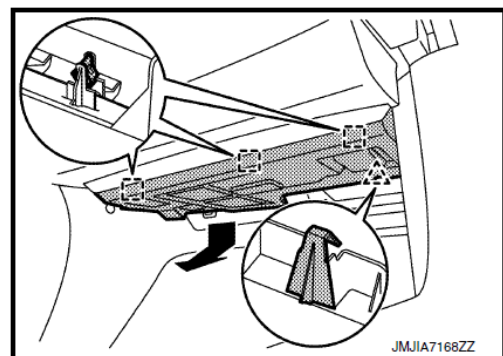
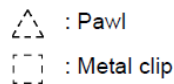
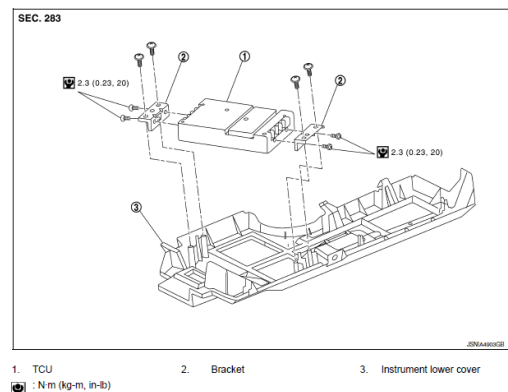

Figure 13

2. Remove the mounting screw and disconnect the connector, and then remove them together with the bracket from instrument lower cover.
3. Remove the bracket mounting screw and remove the bracket from TCU.



1. TCU
2. Bracket
3. Instrument lower cover
☑ : N·m (kg·m, in·lb)

Figure 14

Deactivate the Old TCU and then Activate the new TCU

IMPORTANT: Steps 1 and 2 below must be performed AFTER the original TCU is removed from the vehicle and BEFORE the replacement TCU is installed.

1. Collect and have ready the following information:
 - VIN.
 - International Mobile Equipment Identity Number (IMEI) of the original TCU. This number is located on the TCU.
 - IMEI Number of the replacement TCU. This number is located on the TCU.
 - Serial Number of the replacement TCU. This number is located on the TCU.

LABEL ON TCU



Figure 15

2. Call the INFINITI CONNECTION™ Call Center at 1-800-334-7858, press “1” and listen for additional applicable INFINITI retailer prompts to replace a TCU. (Hours of operation are listed at the bottom of the page.)

NOTE: The phone number shown above is for TCU activation and deactivation **ONLY**. The Support Center agent is unable to assist with matters unrelated to TCU activation and deactivation.

During this call:

- You will be asked for your name, dealership name, and all of the information collected in step 1.
- The Support Center agent will deactivate the original TCU and activate the replacement TCU.

IMPORTANT: Step 2 **MUST** be performed to activate the replacement TCU. If it is not performed the TCU will not be able to communicate with the Infiniti Connection Global Data Center.

Infiniti Connection Call Center – Hours of Operation (Central Time Zone)

Monday – Friday: 7AM – 10PM Saturday: 8AM – 5PM

Special Holiday Hours:

Closed Thanksgiving, Christmas, and New Years Day

Christmas Eve: 7AM – 7PM

New Years Eve: 7AM – 7PM

Install Replacement TCU

- Perform steps 1-3 of **Remove the TCU from the Vehicle** procedure on page 8, in reverse order, to install.

Turn TCU ON

- Perform steps 1-15 of **Turn OFF the TCU** procedure, starting on page 2, to turn the TCU ON and then confirm the **Current status** field shows “On”.

Write VIN Data

1. Select **WRITE VIN (SAVED DATA)**.
2. Select **Start**.

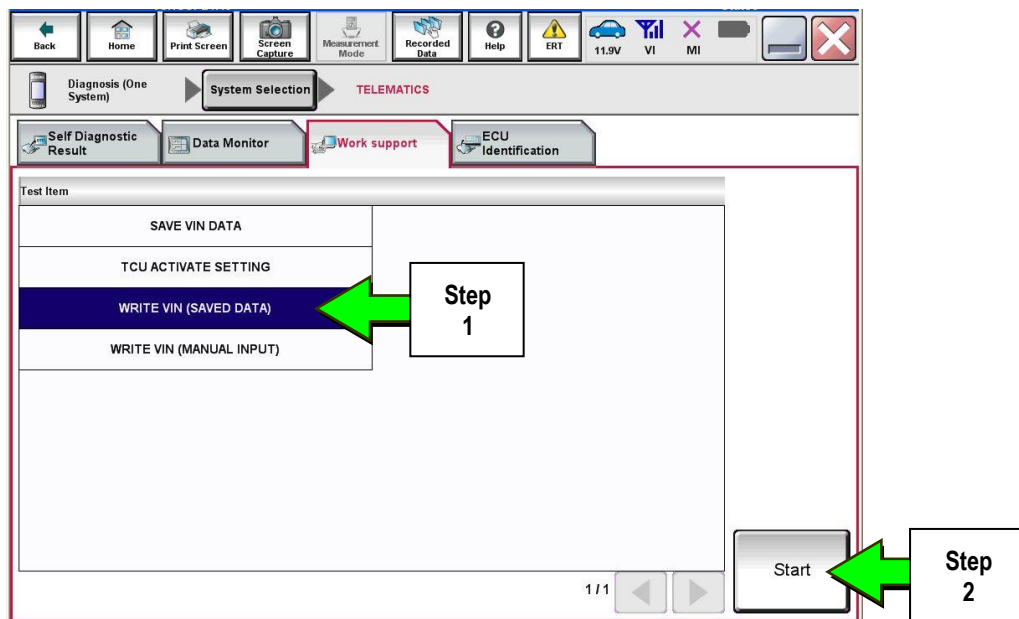

Figure 16

3. Select **Start**.

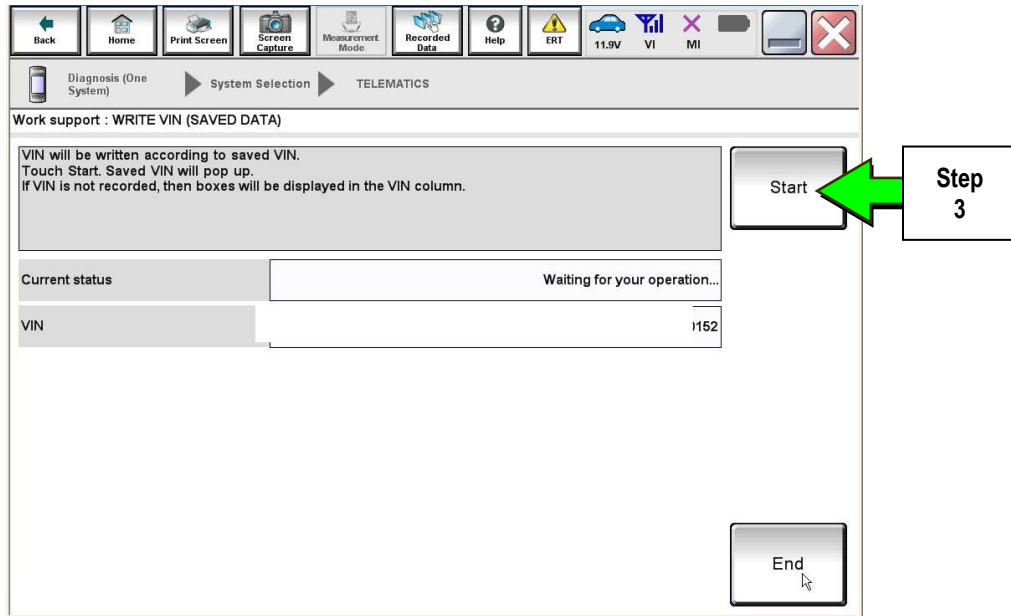

Figure 17

4. Select **End**.

IMPORTANT: Wait at least 2 minutes after the ignition is turned ON before checking for DTCs. If DTCs are checked prior to this a U1000 may be stored.

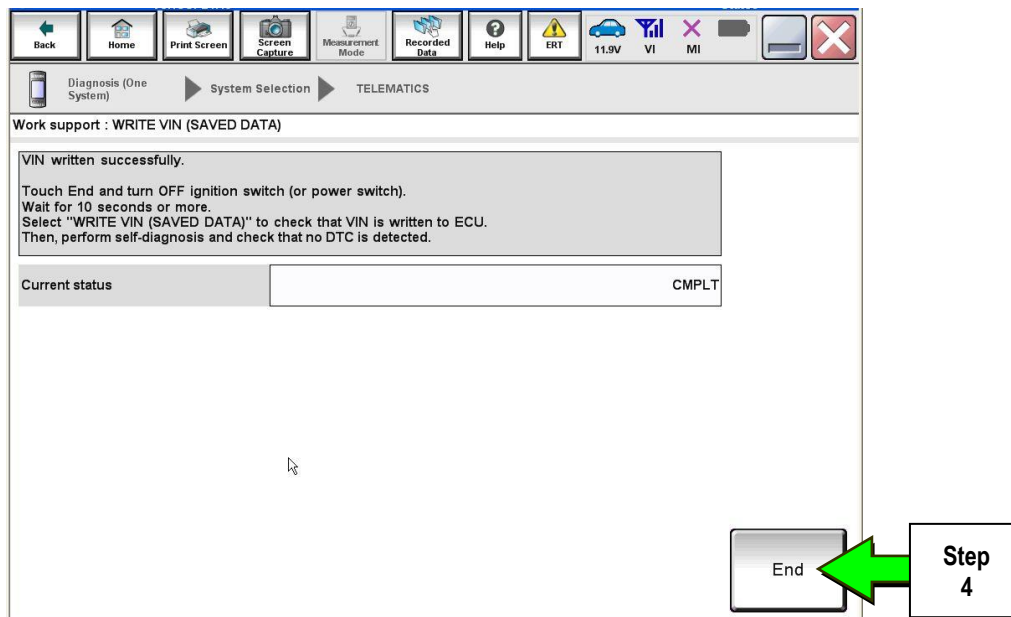

Figure 18

PARTS INFORMATION

Description	PART NUMBER	Quantity
Telematics Control Unit	283B0-3JA5A	1

CLAIMS INFORMATION

Submit a Campaign (CM) line claim using the following claims coding:

CAMPAIGN ("CM") ID	DESCRIPTION	OP CODE	FRT
PC451	Replace Telematics Control Unit (\$299 Co-Pay)	PC4511	0.6 hrs.
PC452	Replace Telematics Control Unit (\$149 Co-Pay)	PC4521	0.6 hrs.
PC454	Replace Telematics Control Unit (Dealer Action Unit – No Co-Pay)	PC4541	0.6 hrs.





JX35 & QX60 Telematics Control Unit Replacement

IMPORTANT: Those steps in **RED** below, under Campaign Overview, **MUST** be performed in the order listed for the new TCU to operate correctly.

Campaign Overview:

1. Turn OFF the original TCU using CONSULT-III plus (C-III plus) (page 2).
2. **Save the VIN DATA using C-III plus (page 7).**
3. Remove the original TCU from the vehicle (page 9).
4. **Deactivate (unregister) the original TCU by calling INFINITI CONNECTION™ Call Center (page 22).**
5. **Activate (register) the replacement TCU by calling INFINITI CONNECTION™ Call Center (page 23).**
6. Install the replacement TCU into the vehicle (page 24).
7. Turn ON the replacement TCU using C-III plus (page 24).
8. **Write the VIN DATA using C-III plus (page 24).**

SERVICE PROCEDURE

Turn OFF the TCU

1. Connect the C-III plus VI to the vehicle.
2. Set the parking brake.
3. Turn the Ignition ON, but do not start the vehicle.
4. Launch C-III plus on the CONSULT PC.
5. Select **Diagnosis (One System)**.

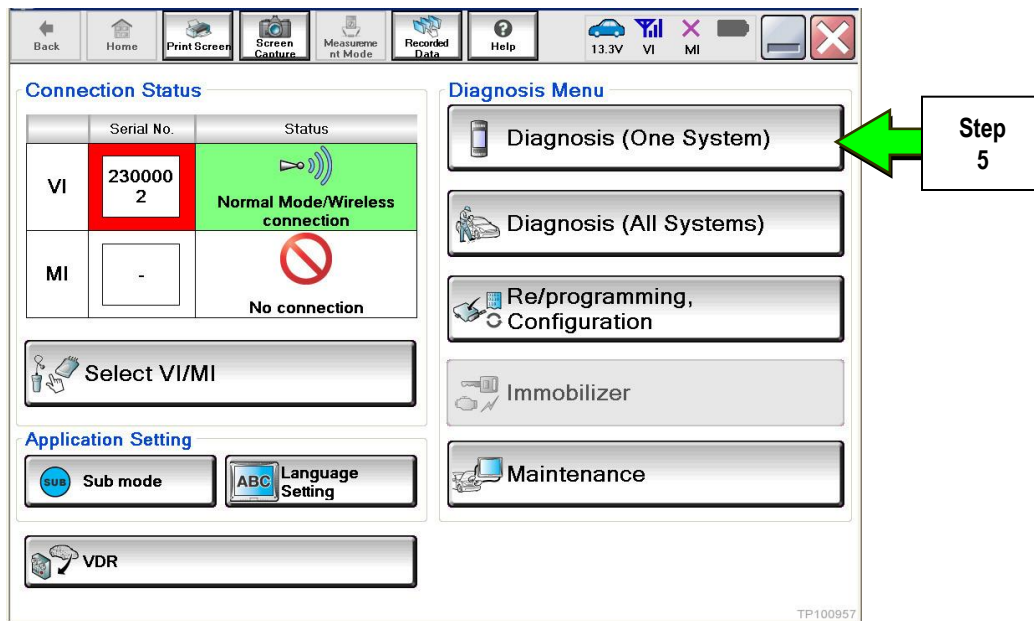

Figure 1

6. Select **TELEMATICS** on page 2 of the “All systems” list.

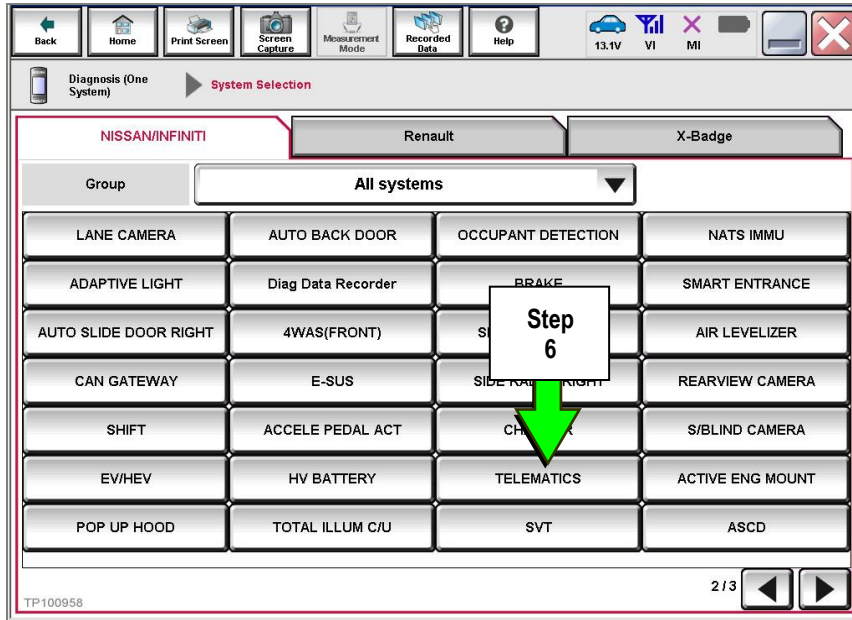

Figure 2

7. Select **Work support**.

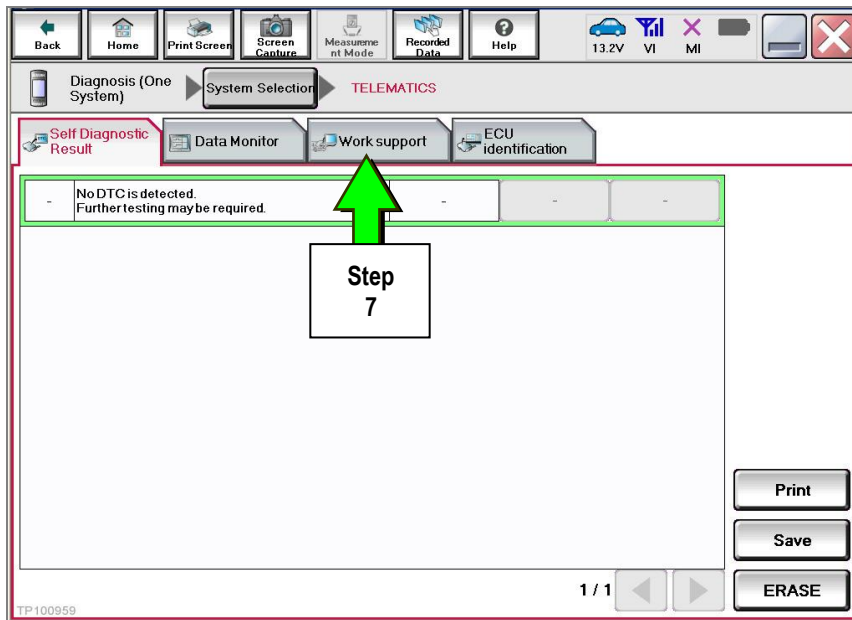

Figure 3

8. Select **TCU ACTIVATE SETTING**.

9. Select **Start**.

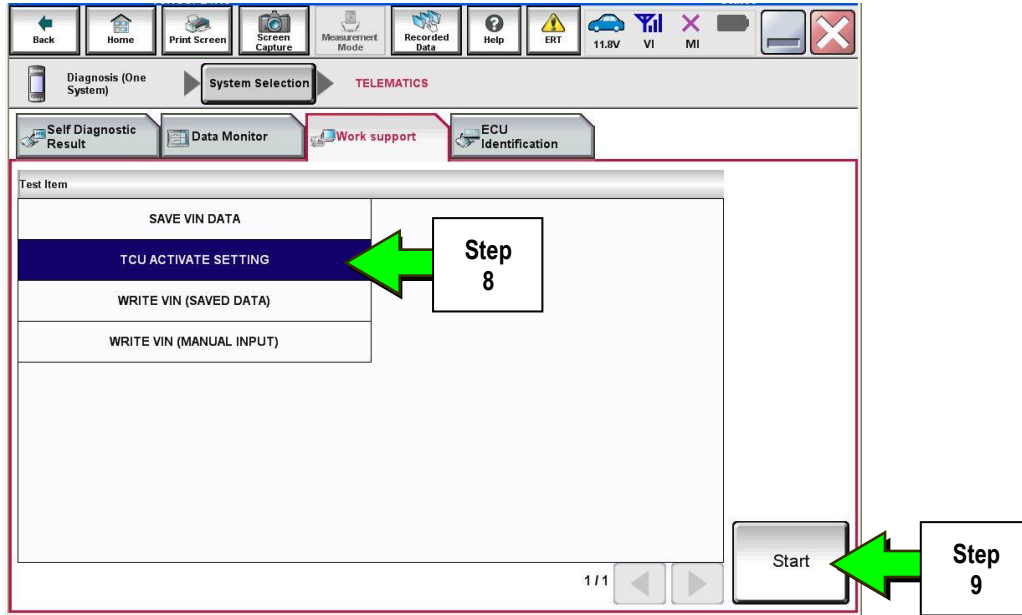

Figure 4

10. Select **Start**.

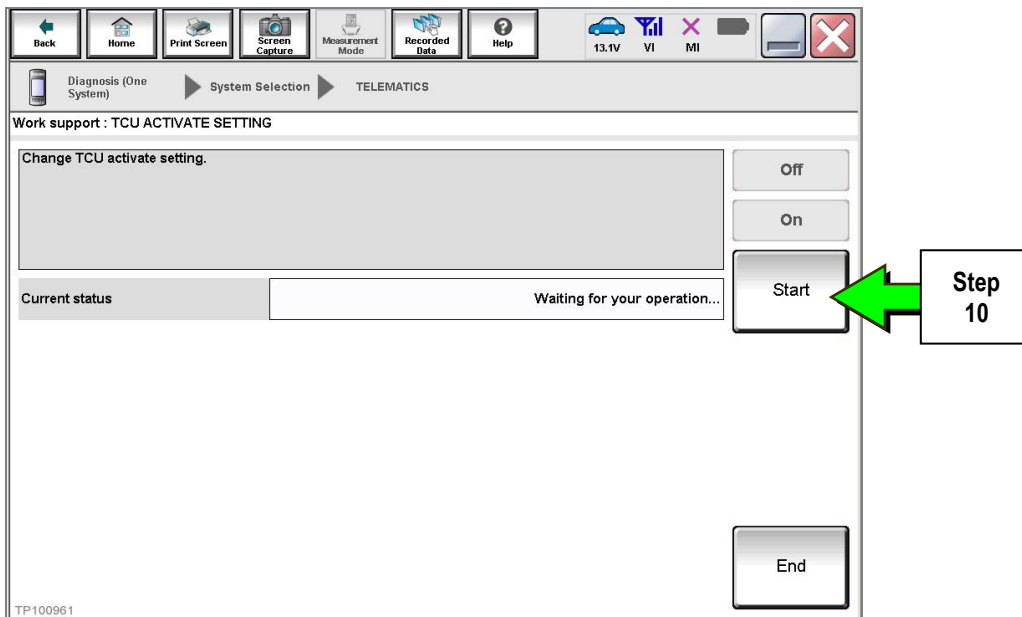

Figure 5

11. Select **Off** to turn OFF the TCU.

12. Select **End**.

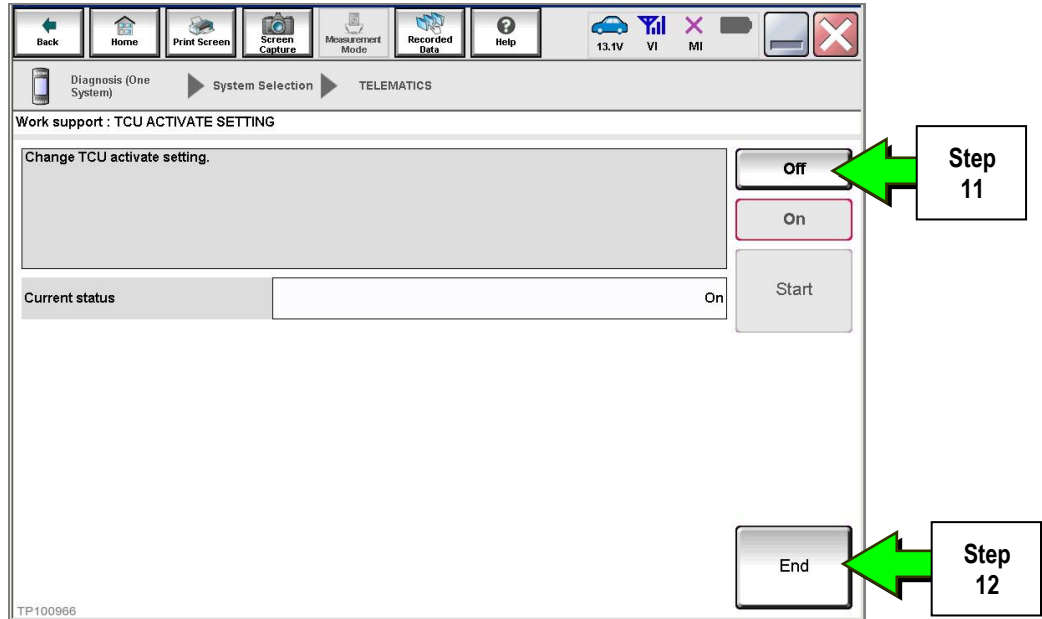

Figure 6

13. Select **Start**.

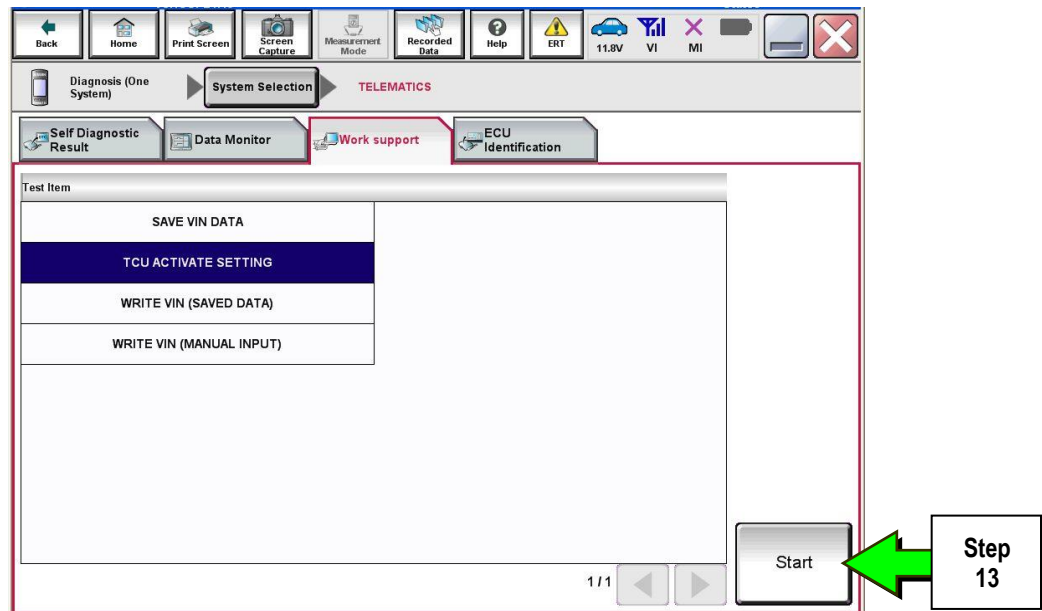

Figure 7

14. Select **Start**.

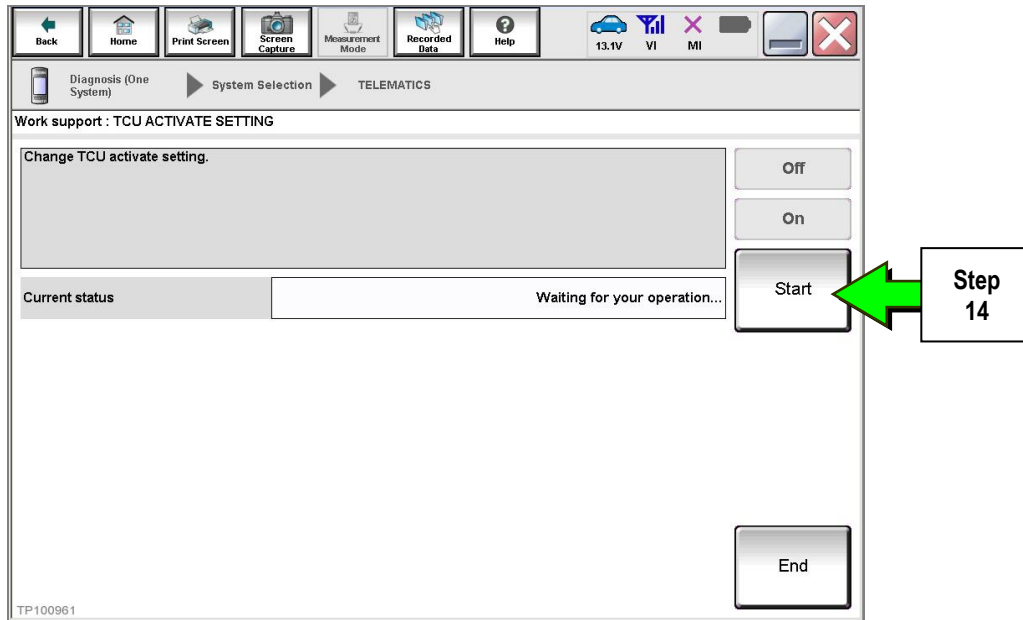

Figure 8

15. Confirm "**Off**" is displayed in the **Current status** field.

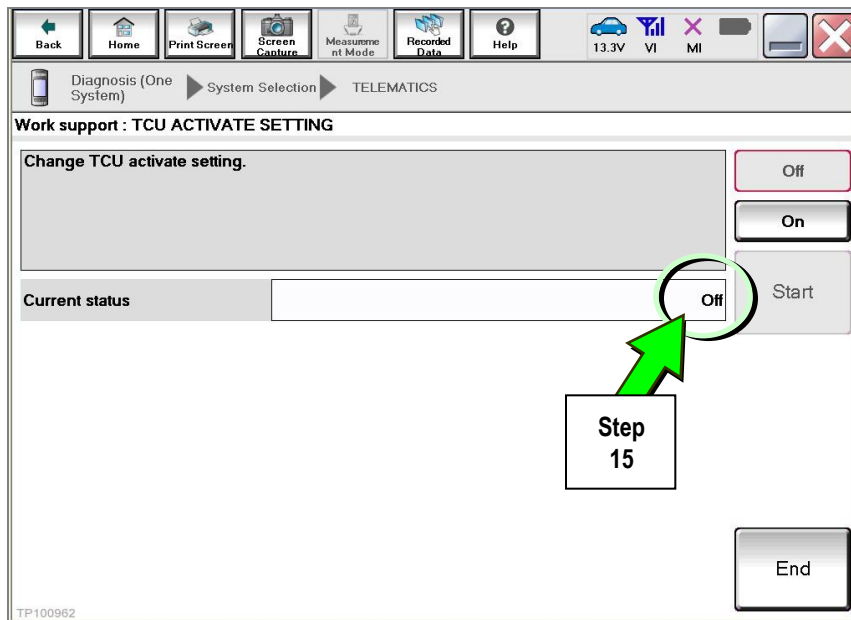

Figure 9

Save VIN Data

1. Select **SAVE VIN DATA**.
2. Select **Start**.

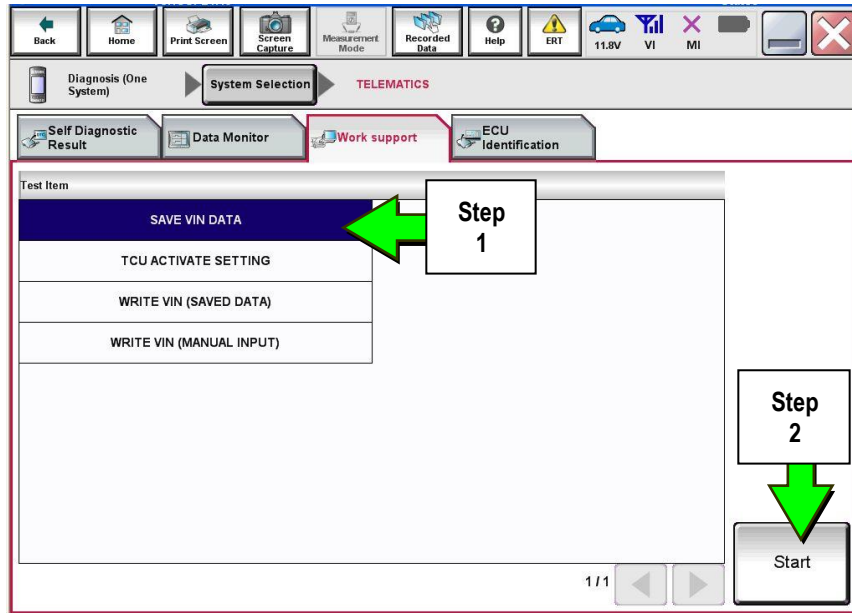

Figure 10

3. Select **Start**.

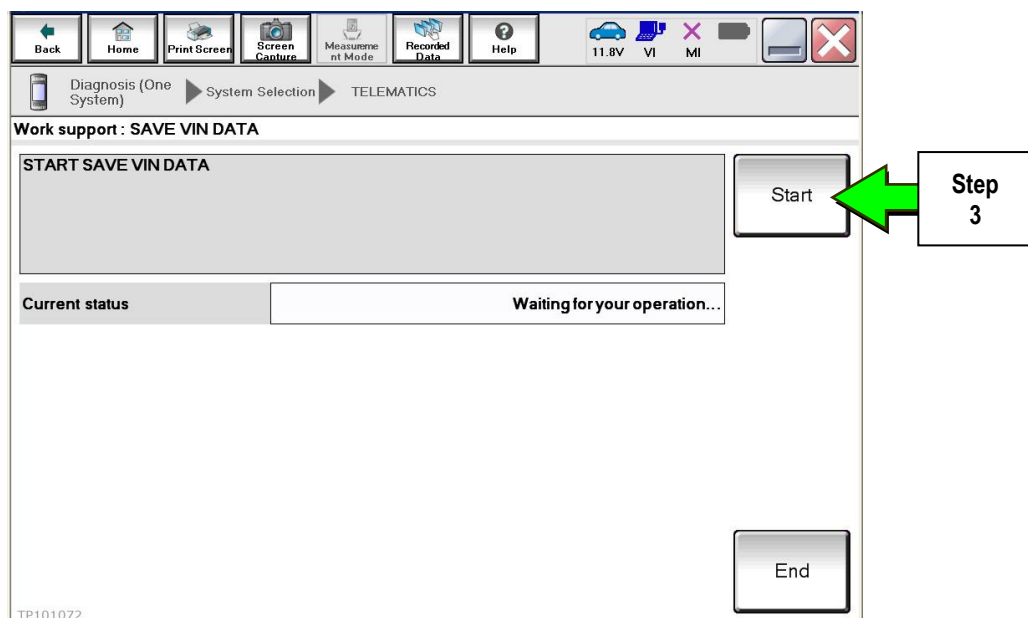

Figure 11

4. Select End.

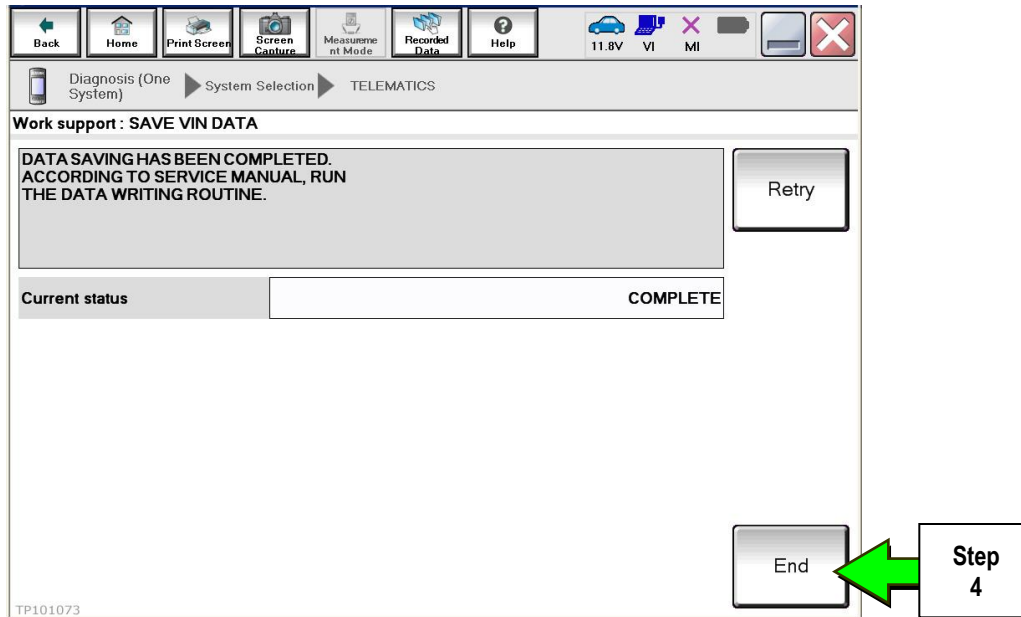

Figure 12

Remove the TCU from the Vehicle.

1. Remove both left and right center console upper side finishers.

NOTE: Driver side shown In Figure 13 and 14. Passenger side similar.

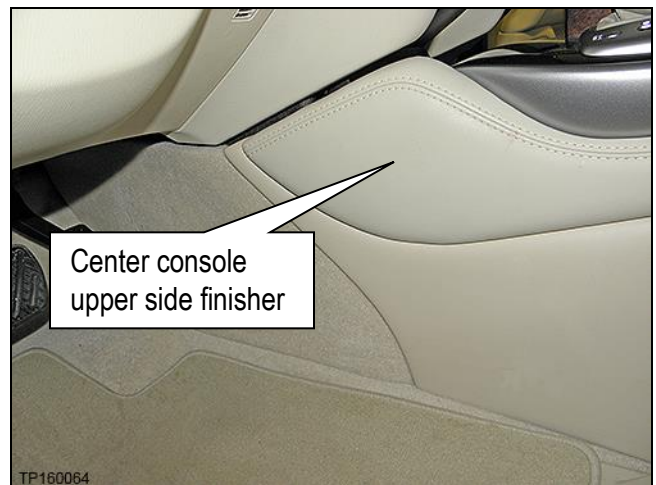

Figure 13

2. Confirm that the metal clips for the left and right upper center console side finisher are in place.
 - If the clips were detached, remove them from the center console and reattach to the upper center console side finishers.

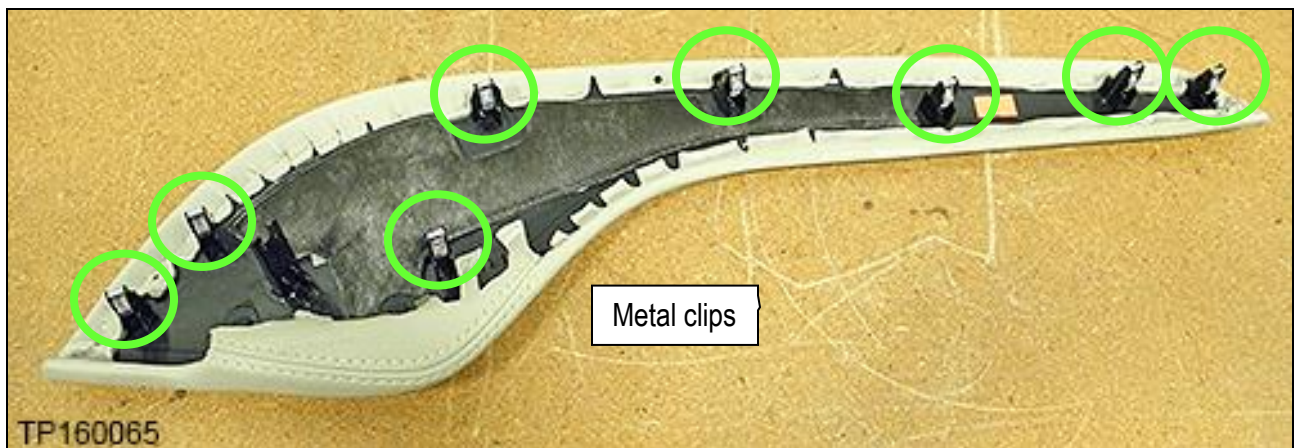

Figure 14

3. Remove both center console side finishers.

NOTE: Driver side shown in Figure 15.



Figure 15

4. Confirm that the plastic clips for the left and right center console side finisher are in place.
 - If the clips were detached, remove them from the center console and reattach to the center console side finishers.

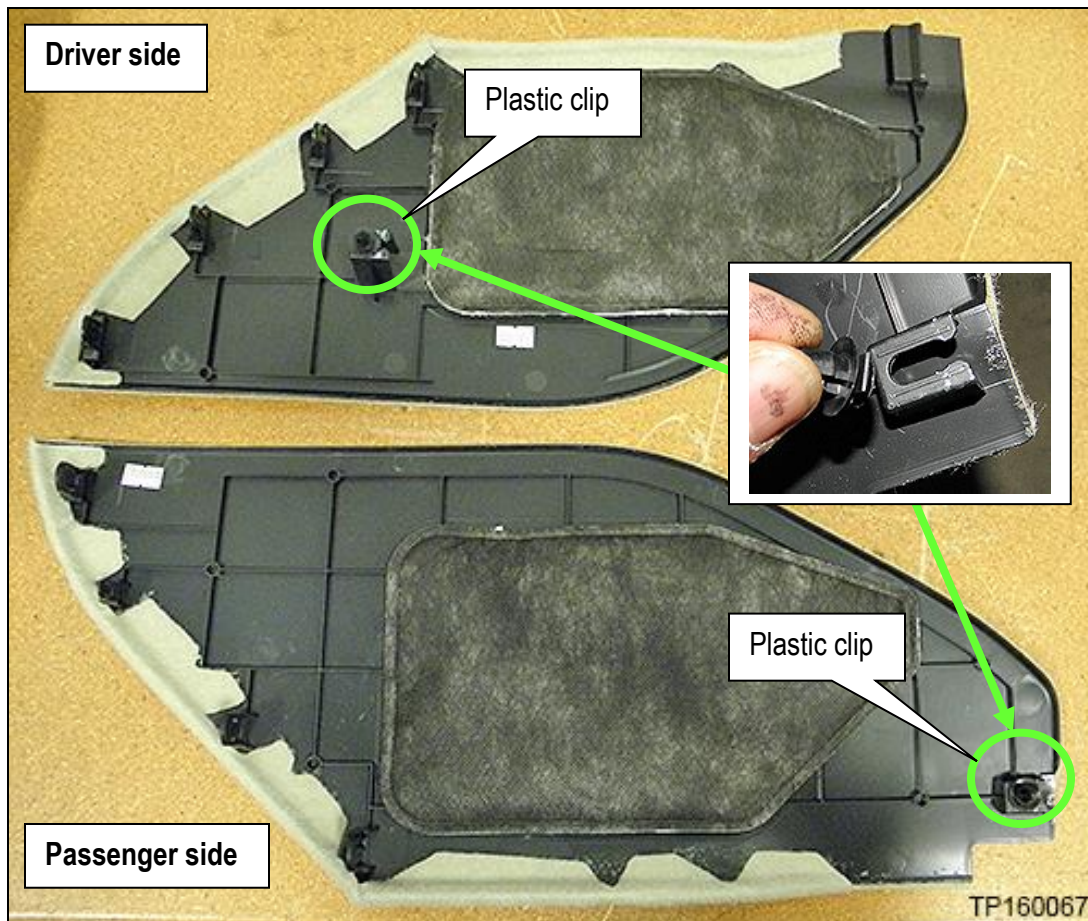

Figure 16

5. Remove the shift knob:



Figure 17

a. Pull shift boot collar down (Figure 18).

b. Remove retaining clip (Figure 18).

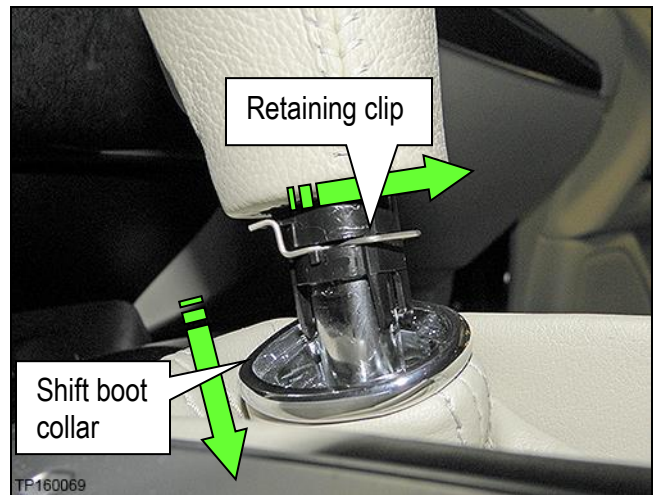

Figure 18

c. Replace retaining clip back onto shift knob (Figure 19).



Figure 19

6. Remove the left and right side screws that retain the shift selector finisher.
 - Four on driver's side (Figure 20).
 - Five on Passenger side (Figure 21).

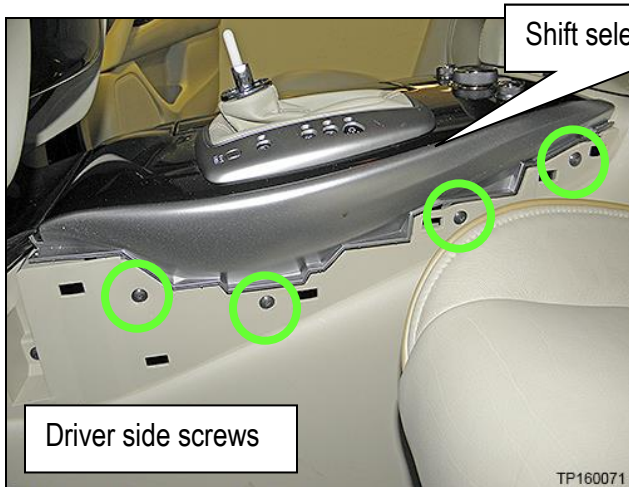

Figure 20

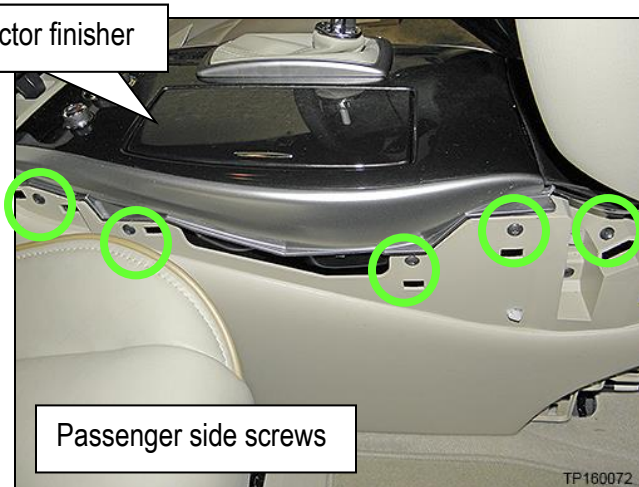

Figure 21

7. Remove one retaining screw and then unclip the front console tray from the center console (Figure 22).

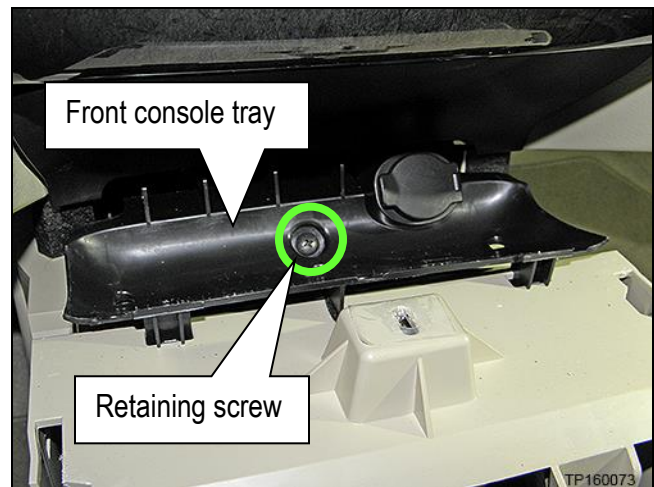

Figure 22

8. Disconnect the harness connector from the 12 volt power receptacle (Figure 23).
 - Leave harness attached to the center console.



Figure 23

9. Remove the shift selector finisher:
 - a. Place a clean shop towel over the front of the shift selector finisher (Figure 24).



Figure 24

- b. Lift the shift selector finisher at the rear.
 - c. While lifting the shift selector finisher, disconnect the four harness connectors exposed at the rear of the center console (Figure 25).
 - d. Separate the shift selector finisher from the center console.

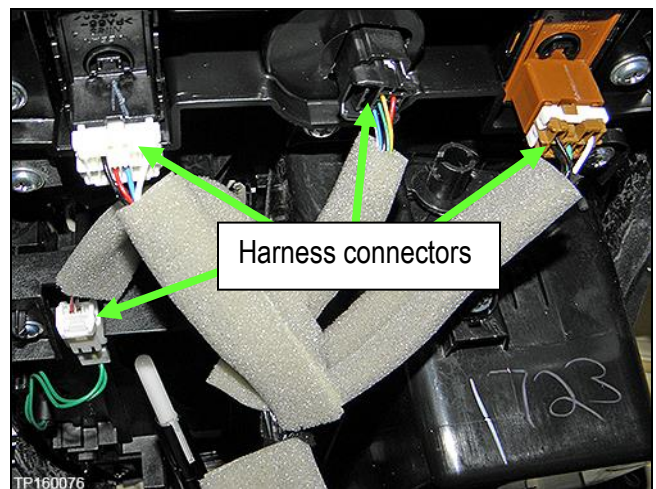

Figure 25

10. Remove the center console rear finisher:

- Six hidden clips (Figure 26).

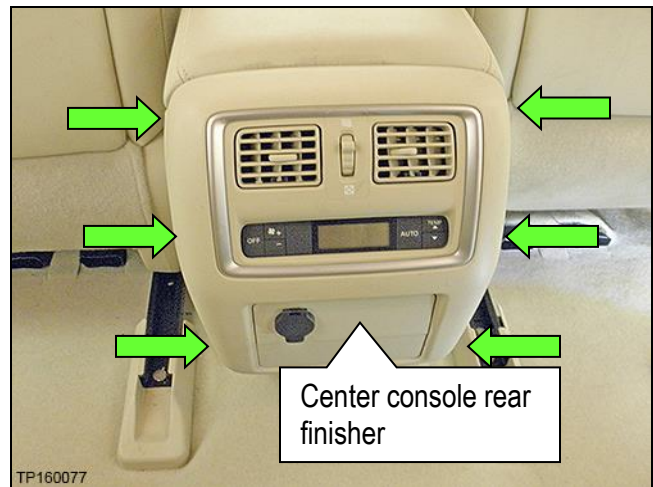

Figure 26

- Lift center console lid.
- Release six clips by gently pulling at the top of the center console rear finisher toward the rear of the vehicle.

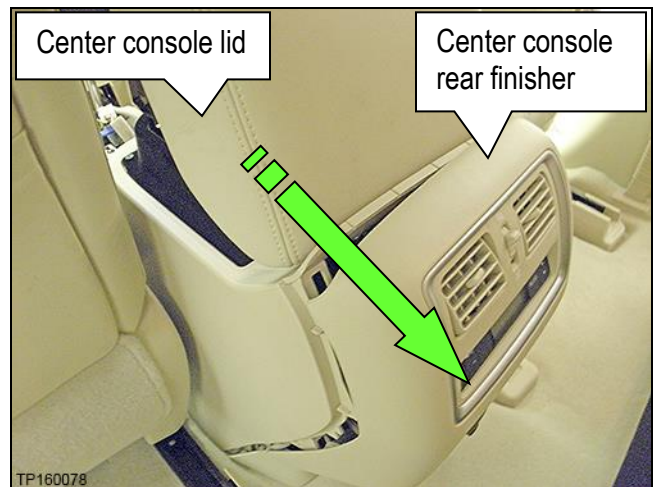

Figure 27

- Lay the center console rear finisher on the vehicle floor.
- Disconnect the two attached harness connectors (Figure 28).

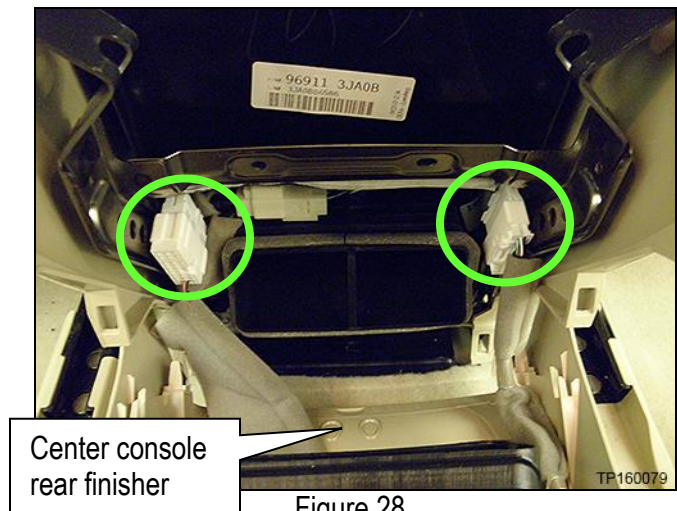

Figure 28

11. Remove the two mounting screws at the bottom rear of the center console (Figure 29).

- Driver's side shown. Passenger side similar.

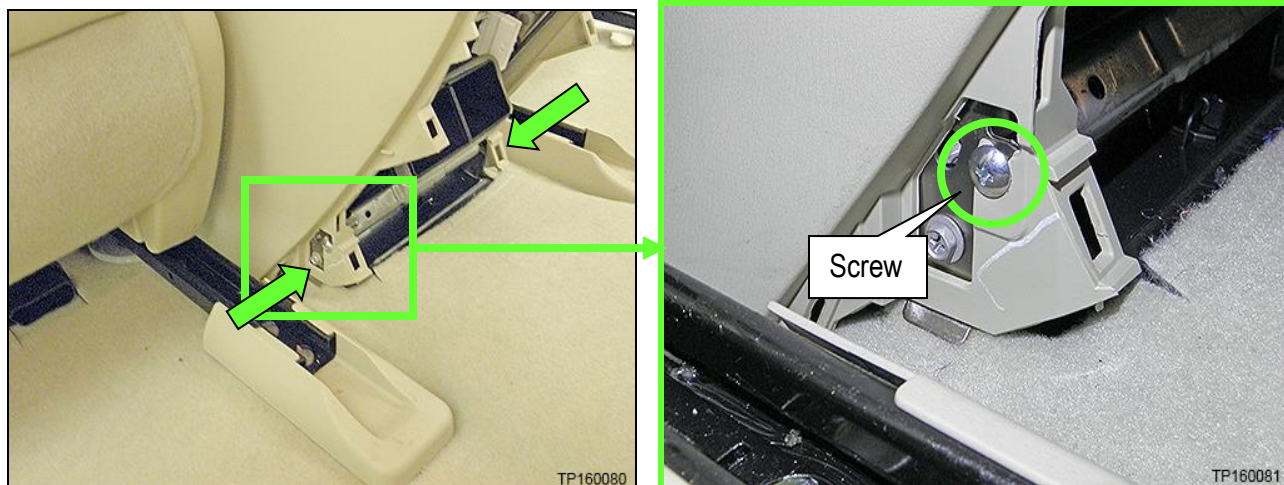

Figure 29

12. Remove one mounting screw from the driver's side and one from the passenger side of the center console (Figure 30)

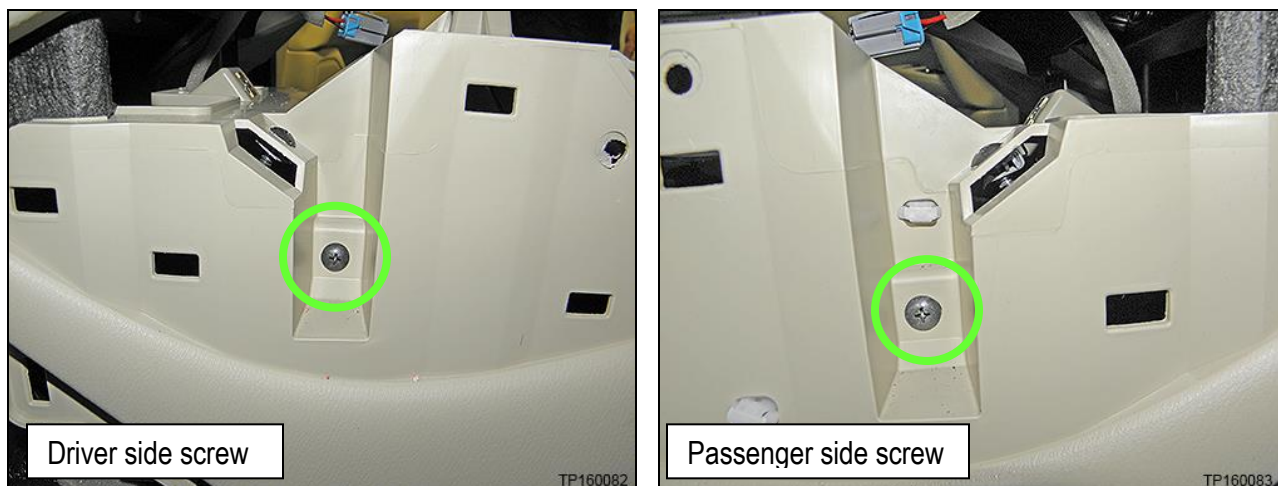

Figure 30

13. Remove the two screws to the left of the shifter.

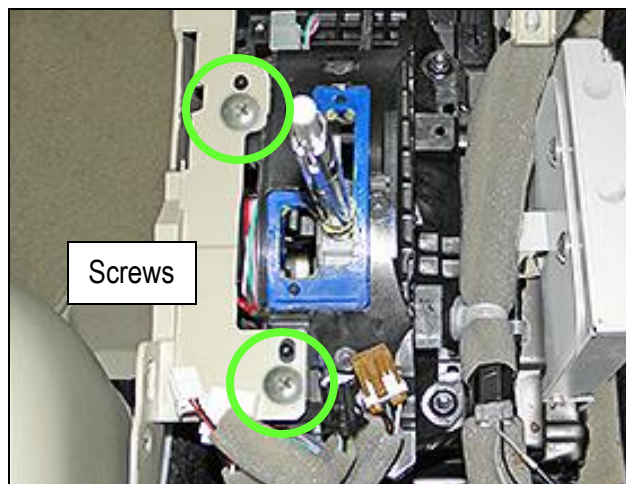

Figure 31

14. Disconnect the harness connectors on the passenger side center console.

- Do not unclip harnesses from center console.

NOTE: There may be three or four connectors depending on the vehicle options.

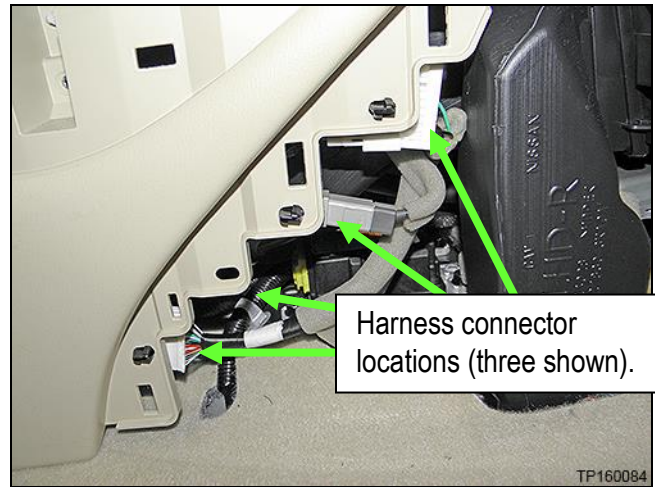

Figure 32

15. Unclip the harness from the shift selector assembly (Figure 33).

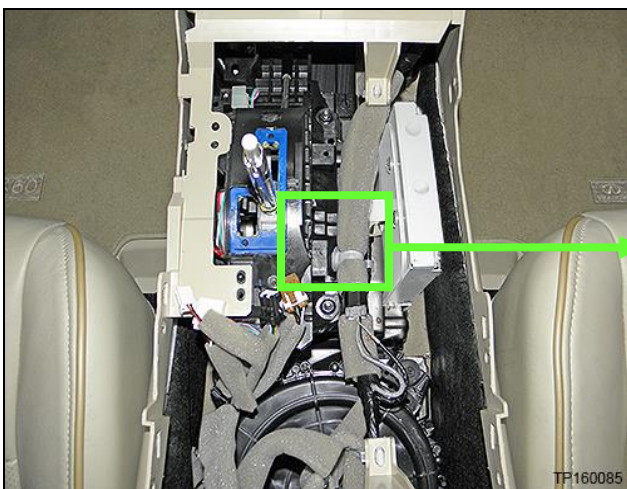

Figure 33

16. Remove the center console (Figure 34).

- a. Gently lift up,
- b. and then rearward.

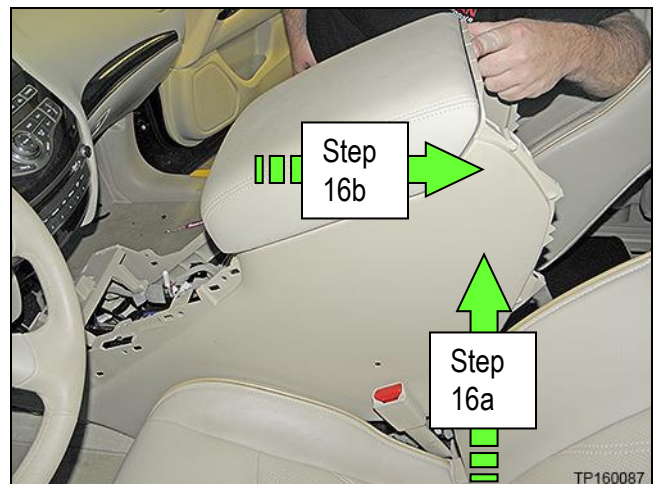

Figure 34

17. Remove the four nuts that attach the shift selector assembly to the center console brace (Figure 35).

NOTE: Top left nut is hidden in Figure 35.

- Reassembly torque to: 7 N•m (0.7 kg-m, **62 in-lb.**)

18. Unclip the two harness clips shown in Figure 34 attached to the center console brace.

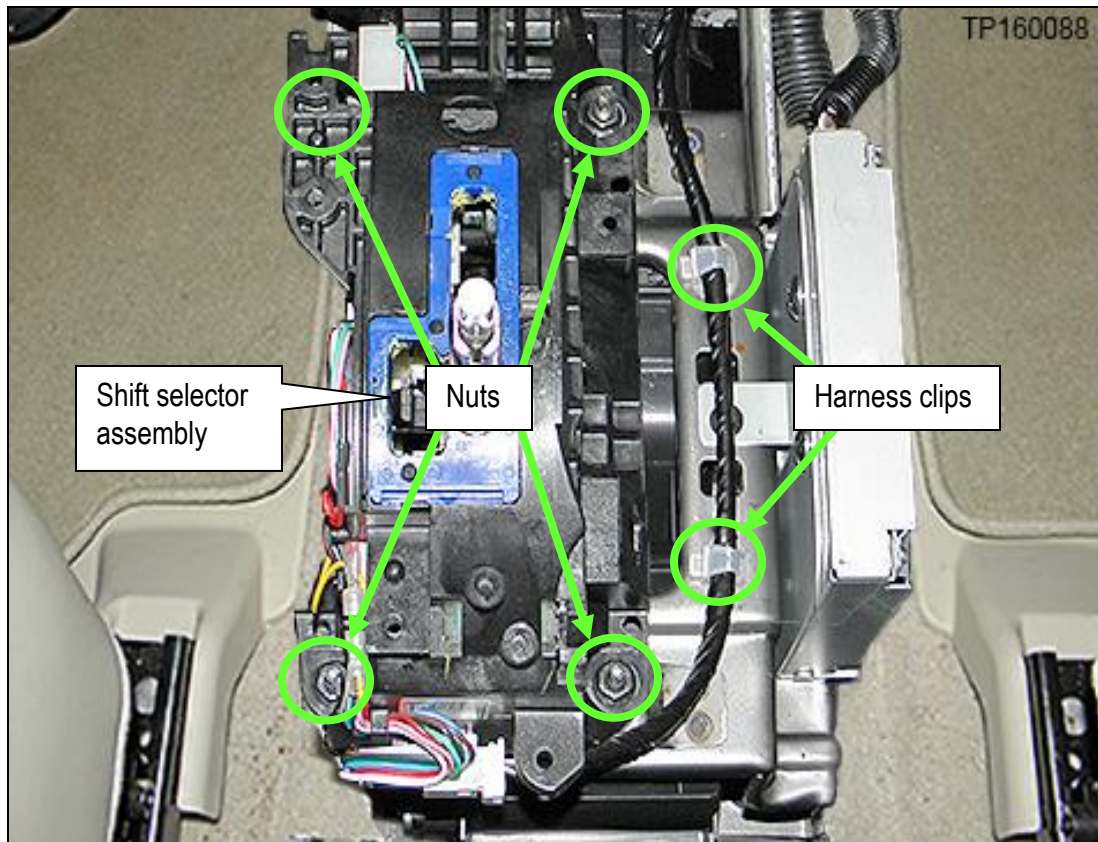

Figure 35

19. Unclip the three harness clips from the center console brace shown in Figure 36.

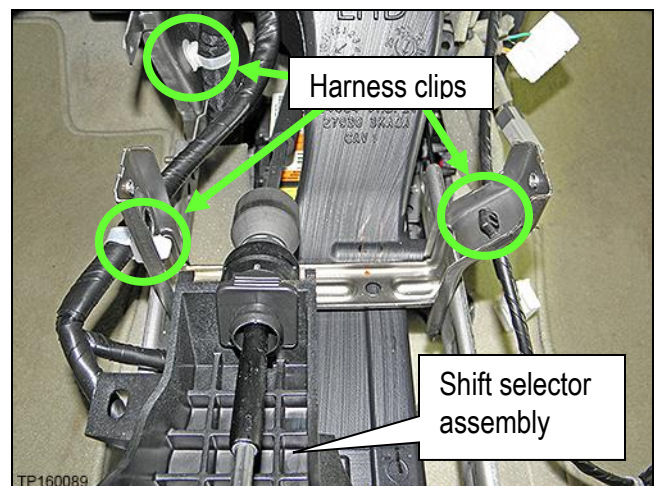

Figure 36

20. Lift the shift selector assembly away from the center console brace and lay it on the driver's side floor (Figure 37).

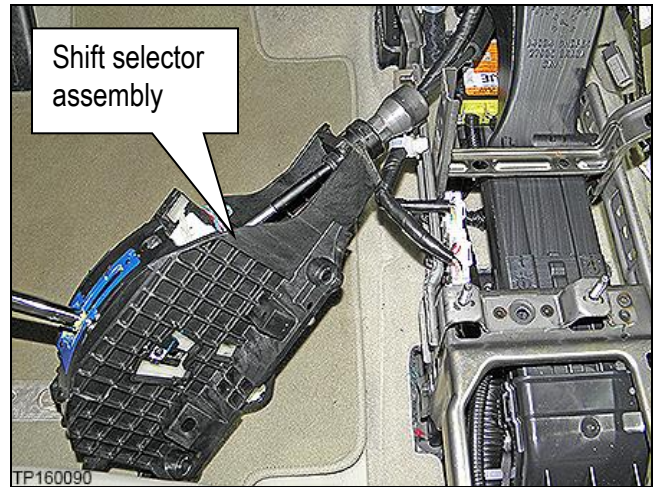

Figure 37

21. Unclip the two harness connectors shown in Figure 38 from the driver's side of the center console brace.

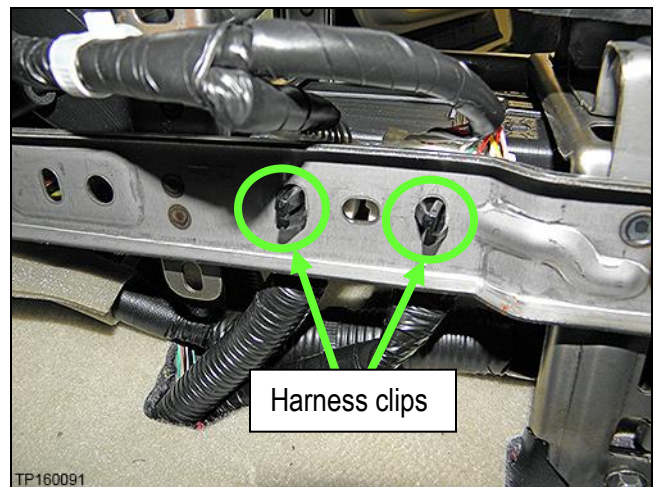

Figure 38

22. Unplug the two harness connectors that were unclipped in step 21 and shown in Figure 39.

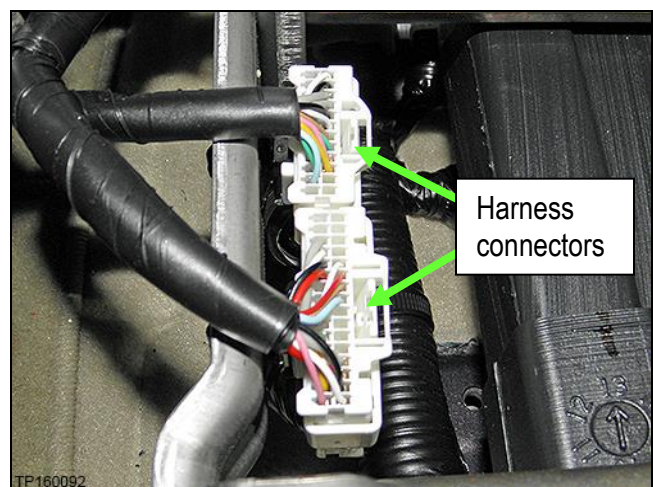

Figure 39

23. Remove the around view monitor control unit from the center console brace (Figure 40).
- Disconnect the harness connectors from the around view monitor control unit.
 - Remove one top screw (not shown) and two bottom screws.

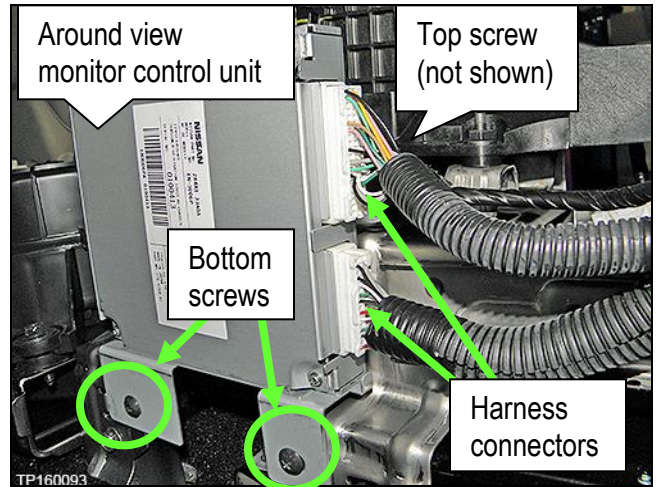

Figure 40

24. Remove the two bolts and one nut on the driver's side of the center console brace.
- Reassembly torque to: 7 N•m (0.7 kg-m, **62 in-lb.**)

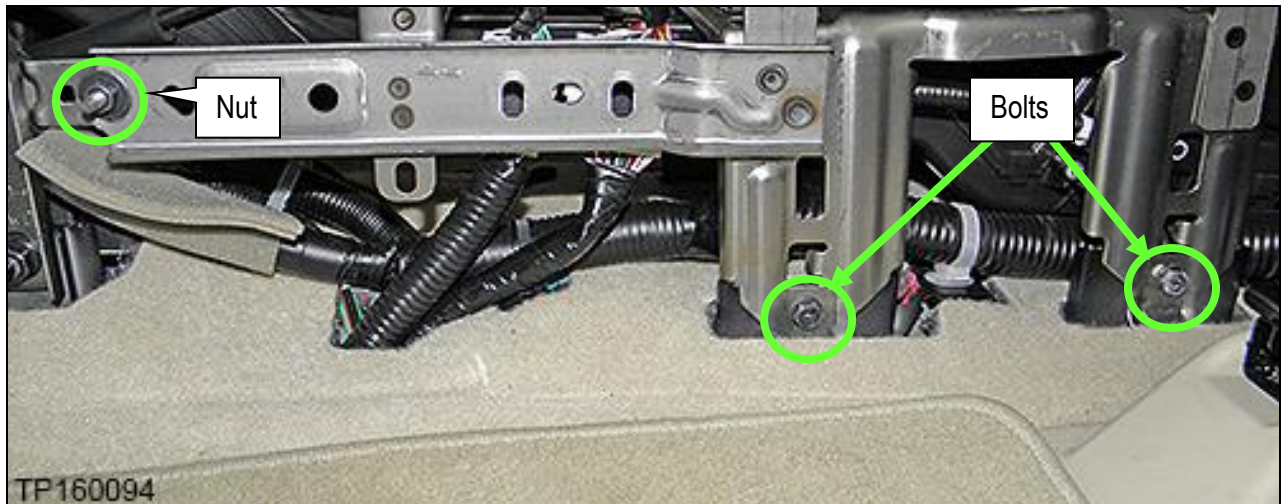

Figure 41

25. Remove the two bolts and one plastic clip on the passenger side of the center console brace.
- Reassembly torque to: 7 N•m (0.7 kg-m, **62 in-lb.**)

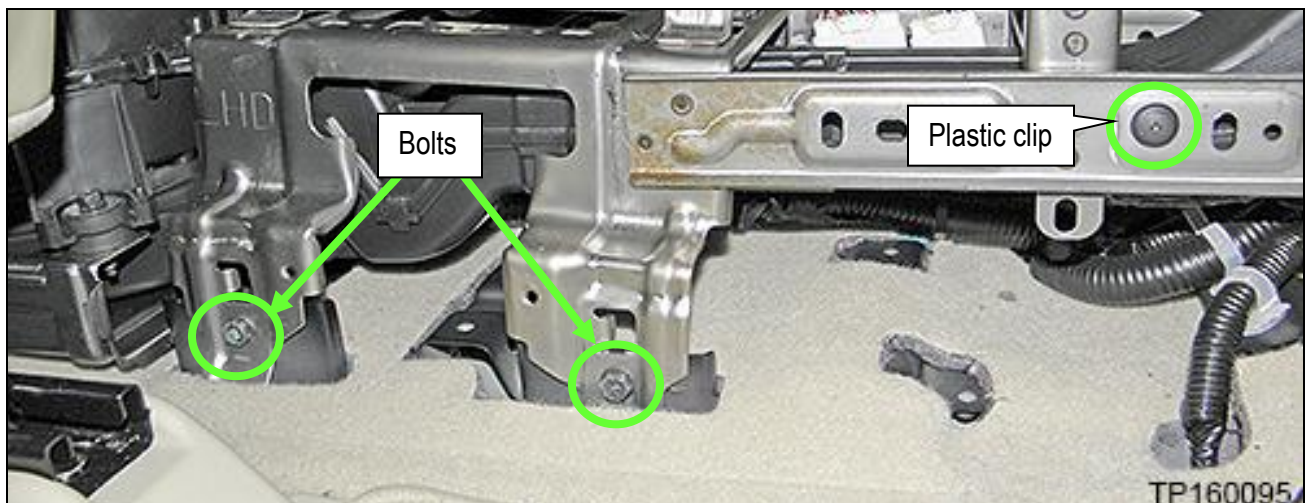

Figure 42

26. Lift the center console brace up at the rear and then remove.

CAUTION: The center console brace may have some sharp edges. Use care when removing it.

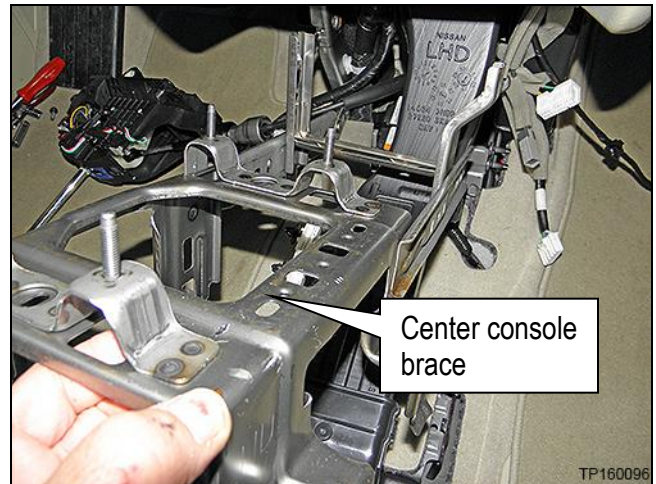

Figure 43

27. Push the adapter duct forward to detach from the rear blower unit assembly and then remove.

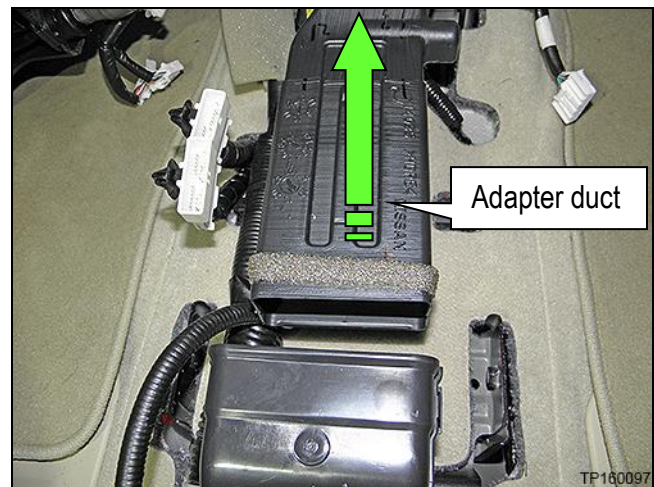

Figure 44

28. Unbolt the 3 bolts that retain the rear blower unit assembly (Figure 45) and then move it to gain access to the “Telematics Control Unit” (TCU).

NOTE: Do not disconnect harnesses to the rear blower unit assembly.

- Reassembly torque to:
7 N•m (0.7 kg-m, 62 in-lb.)

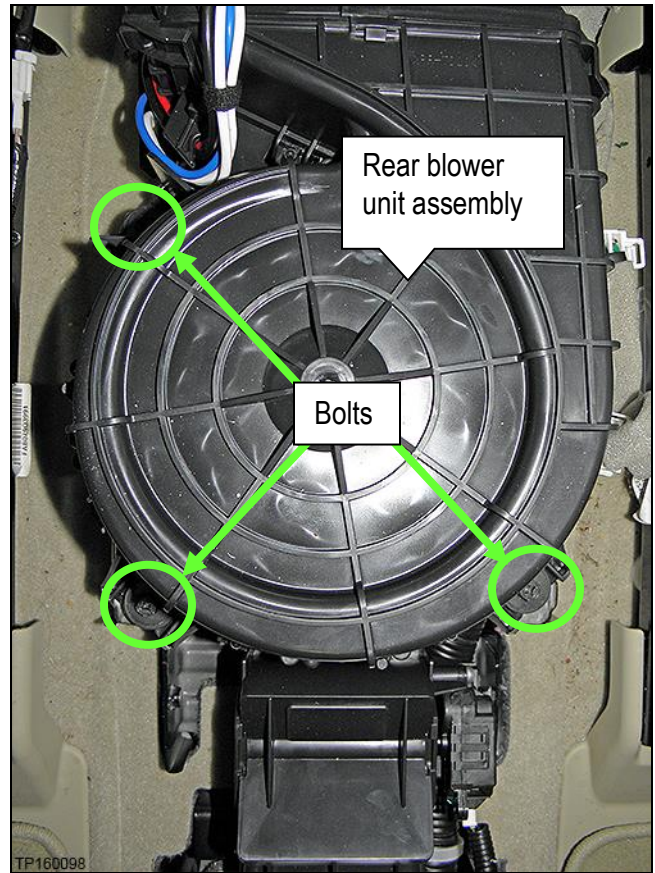

Figure 45

29. Disconnect the three harness connectors from the TCU (Figure 46).

30. Unclip the antenna support clip from the TCU bracket (Figure 46).

31. Unbolt the four bolts that attach the TCU to the vehicle floor (Figure 46)

- One bolt hidden in Figure 46.
- Reassembly torque to: 10.1 N•m (1.0 kg-m, 7 ft-lb.)

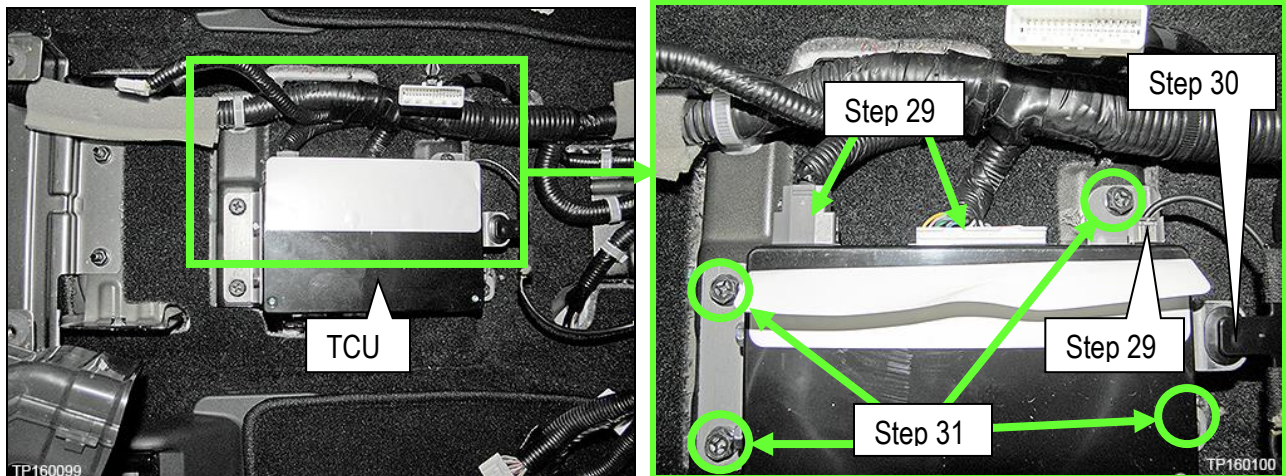

Figure 46

32. Transfer the brackets from the old TCU to the new one.
 - a. Remove the two bolts that attach the front and rear TCU brackets; four total (Figure 47).
 - b. Transfer the brackets to the new TCU and install bolts.
 - Reassembly torque to: 5.5 N•m (0.56 kg-m, **49 in-lb.**)

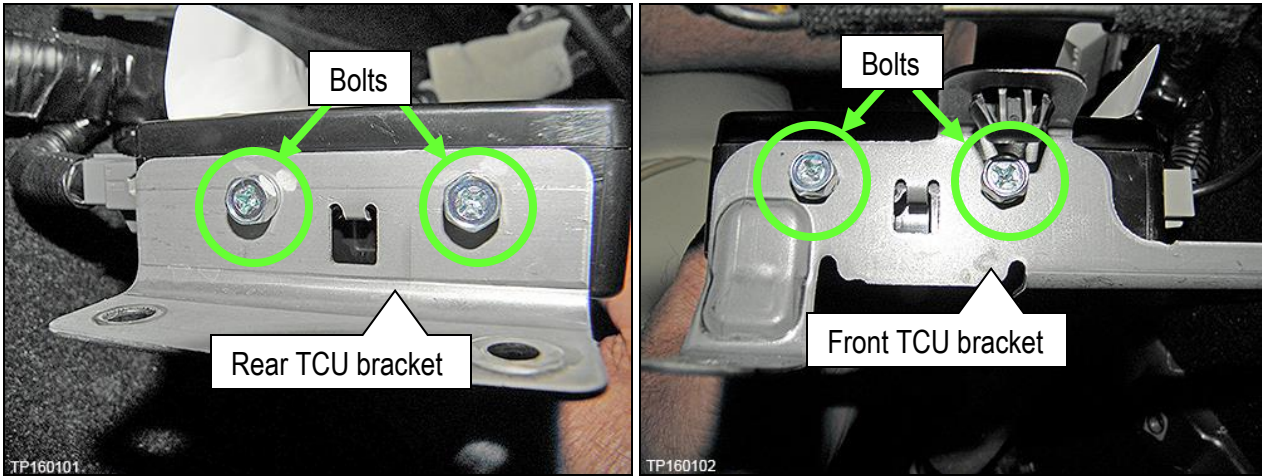

Figure 47

Deactivate the Old TCU and Activate the new TCU

Steps 1 and 2 below must be performed AFTER the original TCU is removed from the vehicle and BEFORE the replacement TCU is installed.

1. Collect and have ready the following information:
 - VIN.
 - International Mobile Equipment Identity Number (IMEI) of the original TCU. This number is located on the TCU.
 - IMEI Number of the replacement TCU. This number is located on the TCU.
 - Serial Number of the replacement TCU. This number is located on the TCU.

LABEL ON TCU



Figure 48

2. Call the INFINITI CONNECTION™ Call Center at 1-800-334-7858, press “1” and listen for additional applicable INFINITI retailer prompts to replace a TCU. (Hours of operation are listed at the bottom of the page.)

NOTE: The phone number shown above is for TCU activation and deactivation **ONLY**. The Support Center agent is unable to assist with matters unrelated to TCU activation and deactivation.

During this call:

- You will be asked for your name, dealership name, and all of the information collected in step 1.
- The Support Center agent will deactivate the original TCU and activate the replacement TCU.

IMPORTANT: Step 2 MUST be performed to activate the replacement TCU. If it is not performed the TCU will not be able to communicate with the Infiniti Connection Global Data Center.

Infiniti Connection Call Center – Hours of Operation (Central Time Zone)

Monday – Friday: 7AM – 10PM Saturday: 8AM – 5PM

Special Holiday Hours:

Closed Thanksgiving, Christmas, and New Years Day

Christmas Eve: 7AM – 7PM

New Years Eve: 7AM – 7PM

Install Replacement TCU

- Install the new TCU into the vehicle and reassemble the center console in the reverse order of disassembly.

Turn TCU ON

- Perform steps 1-15 of **Turn OFF the TCU** procedure, starting on page 2, to turn the TCU ON and then confirm the **Current status** field shows “On”.

Write VIN Data

1. Select **WRITE VIN (SAVED DATA)**.
2. Select **Start**.

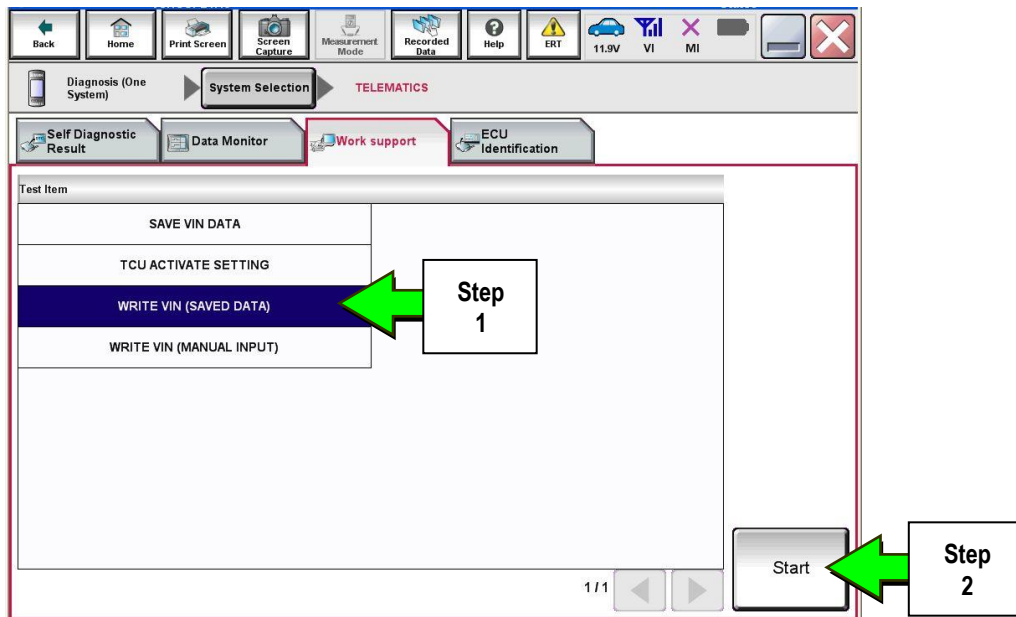

Figure 49

3. Select **Start**.

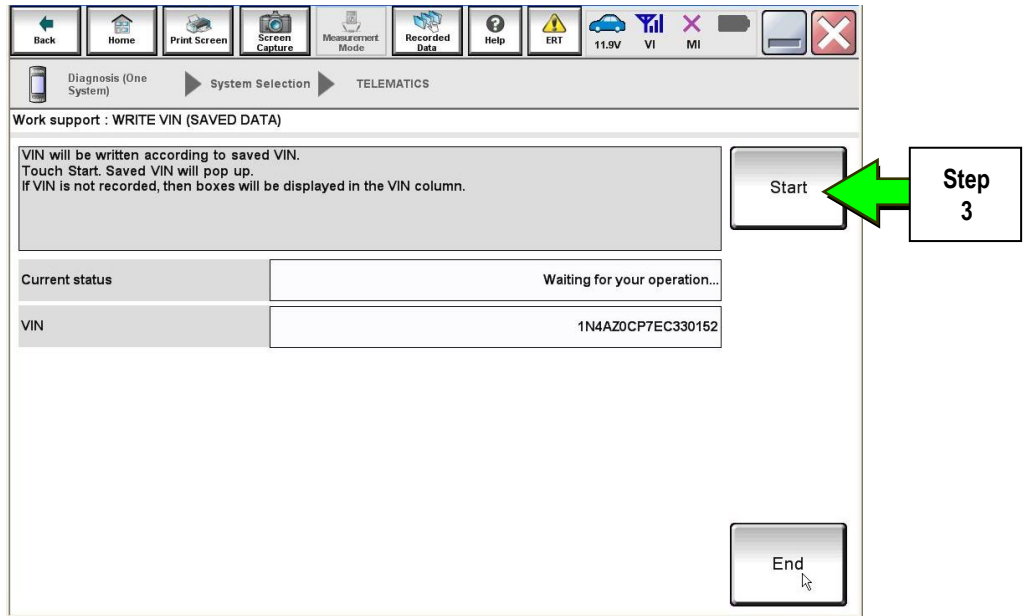

Figure 50

4. Select **End**.

IMPORTANT: Wait at least 2 minutes after the ignition is turned ON before checking for DTCs. If DTCs are checked prior to this a U1000 may be stored.

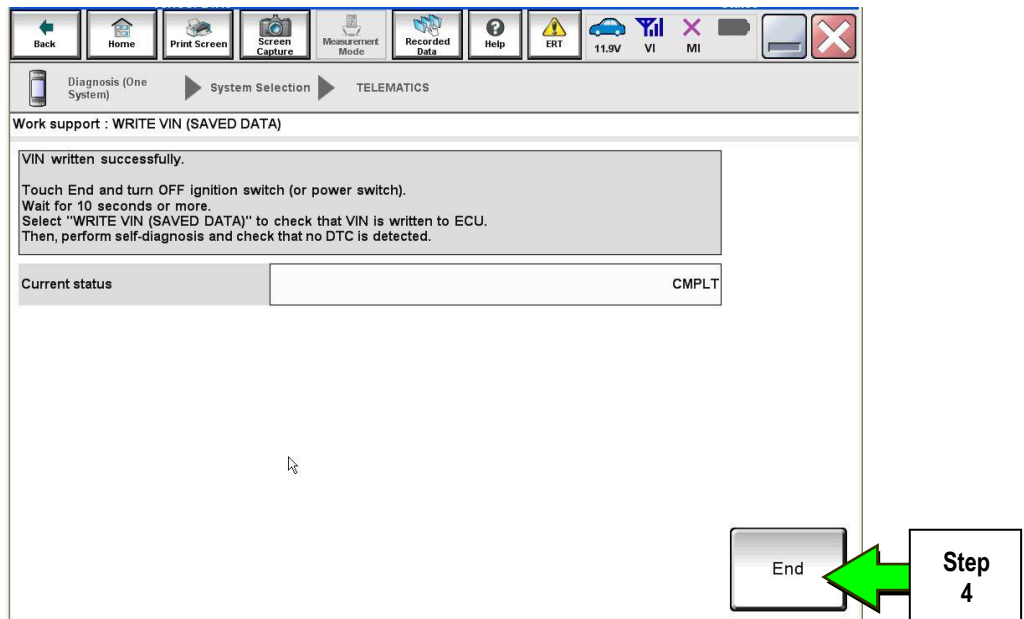

Figure 51

PARTS INFORMATION

Description	PART NUMBER	Quantity
Telematics Control Unit	283B0-3JA5A	1

CLAIMS INFORMATION

Submit a Campaign (CM) line claim using the following claims coding:

CAMPAIGN ("CM") ID	DESCRIPTION	OP CODE	FRT
PC451	Replace Telematics Control Unit (\$299 Co-Pay)	PC4512	1.1 hrs.
PC452	Replace Telematics Control Unit (\$149 Co-Pay)	PC4522	1.1 hrs.
PC454	Replace Telematics Control Unit (Dealer Action Unit – No Co-Pay)	PC4542	1.1 hrs.





QX56 & QX80 Telematics Control Unit Replacement

IMPORTANT: Those steps in **RED** below, under Campaign Overview, **MUST** be performed in the order listed for the new TCU to operate correctly.

Campaign Overview:

1. Turn OFF the original TCU using CONSULT-III plus (C-III plus) (Page 2).
2. **Save the VIN DATA using C-III plus (Page 7).**
3. Remove the original TCU from the vehicle (Page 8).
4. **Deactivate (unregister) the original TCU by calling INFINITI CONNECTION™ Call Center (Page 10).**
5. **Activate (register) the replacement TCU by calling INFINITI CONNECTION™ Call Center (Page 10).**
6. Install the replacement TCU in the vehicle (Page 11).
7. Turn ON the replacement TCU using C-III plus (Page 11).
8. **Write the VIN DATA using C-III plus (Page 11).**

SERVICE PROCEDURE

Turn OFF the TCU

1. Connect the C-III plus VI to the vehicle.
2. Set the parking brake.
3. Turn the Ignition ON, but do not start the vehicle.
4. Launch C-III plus on the CONSULT PC.
5. Select **Diagnosis (One System)**.

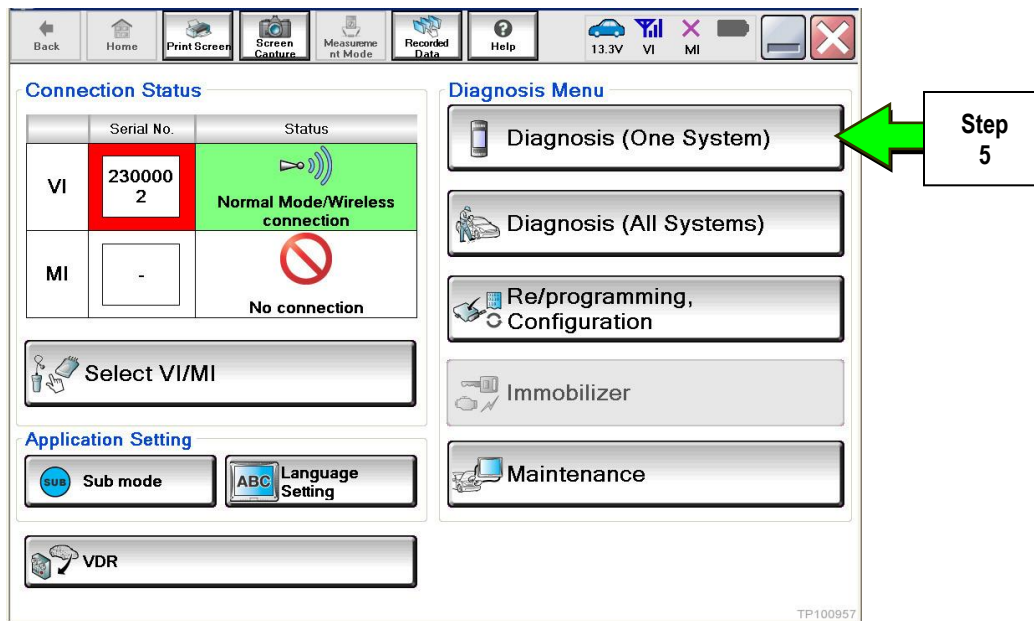

Figure 1

6. Select **TELEMATICS** on page 2 of the “All systems” list.

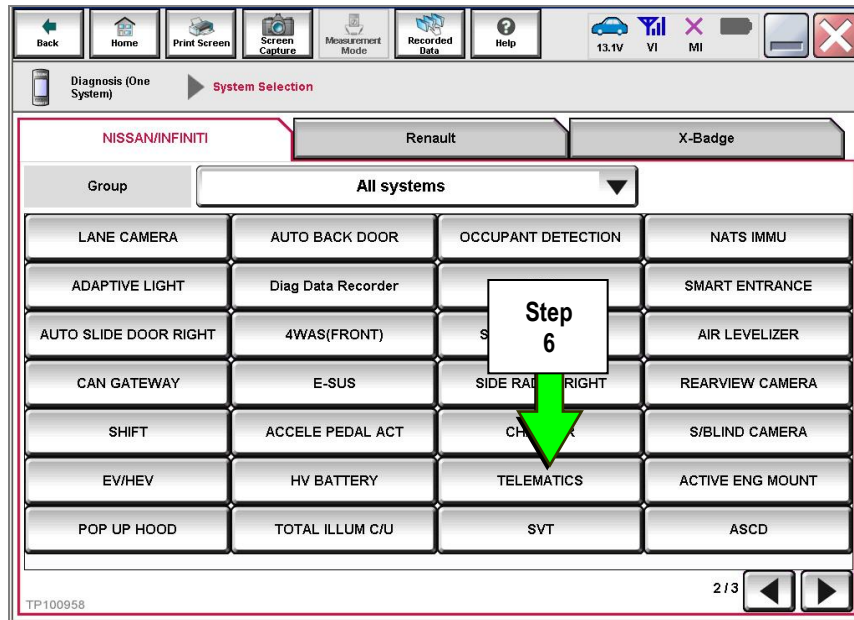

Figure 2

7. Select **Work support**.

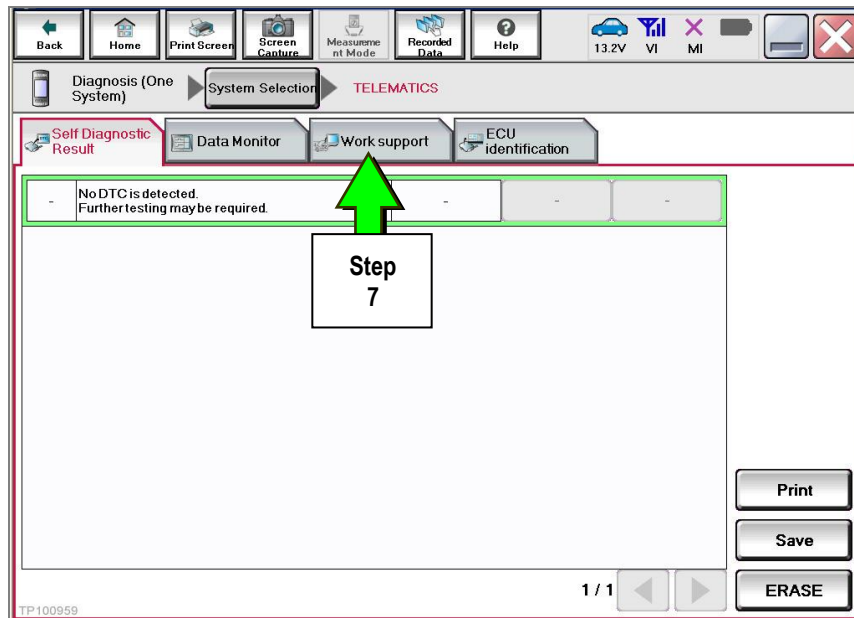

Figure 3

8. Select **TCU ACTIVATE SETTING**.

9. Select **Start**.

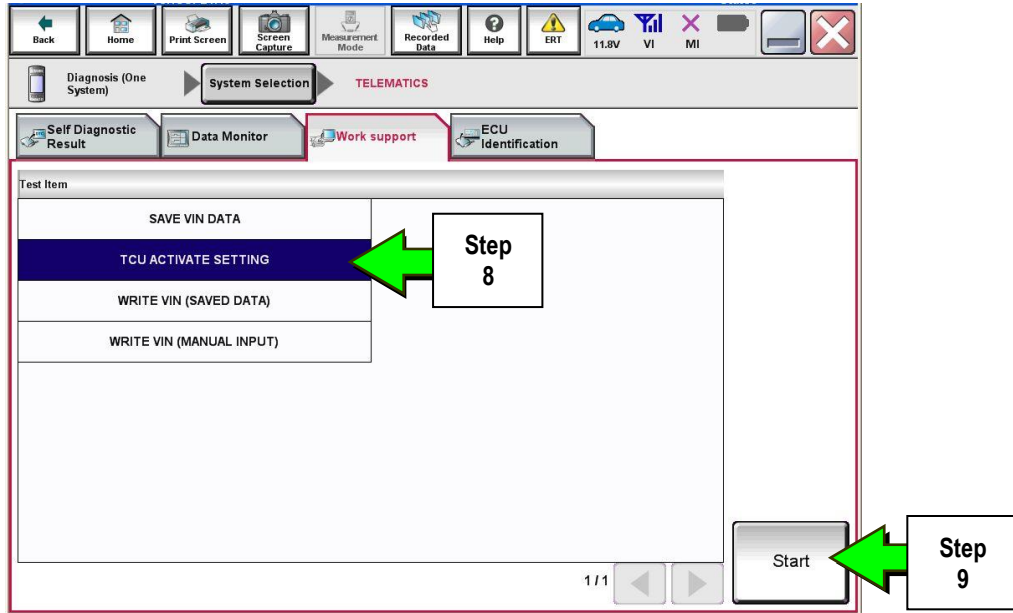

Figure 4

10. Select **Start**.

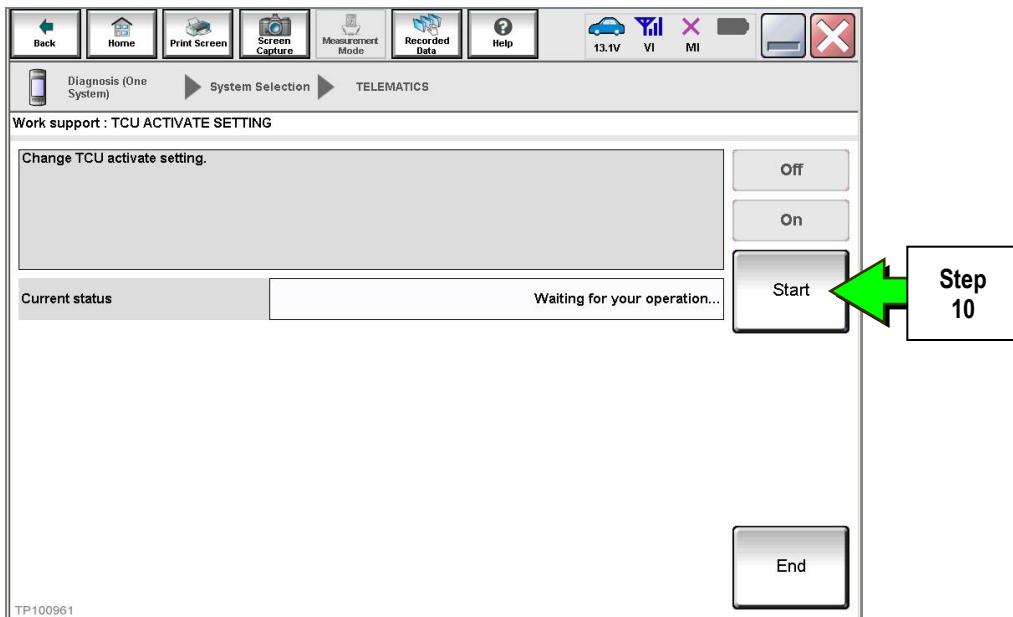

Figure 5

11. Select **Off** to turn OFF the TCU.

12. Select **End**.

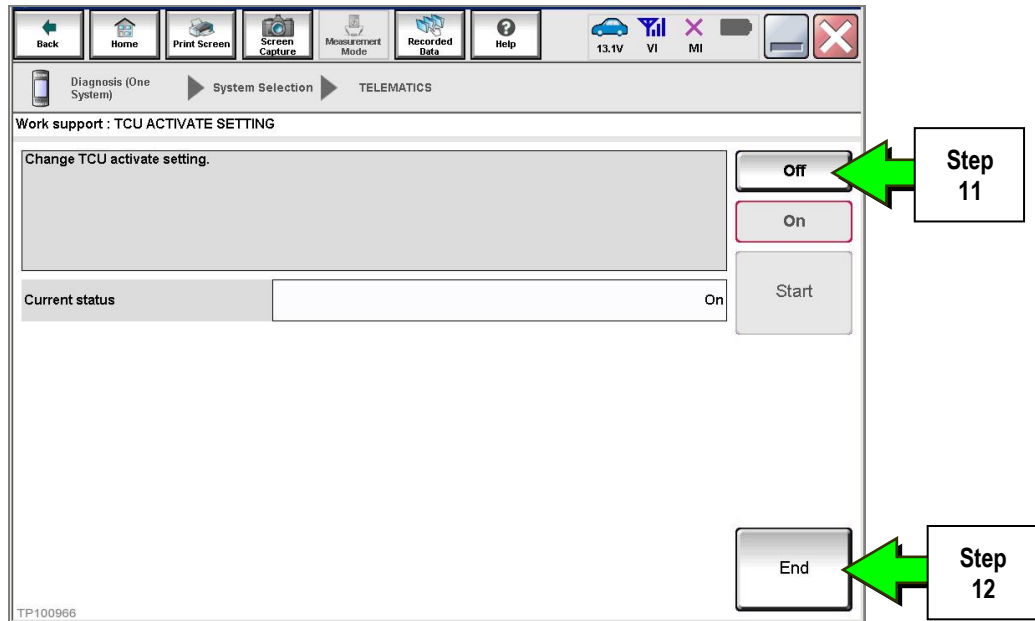

Figure 6

13. Select **Start**.

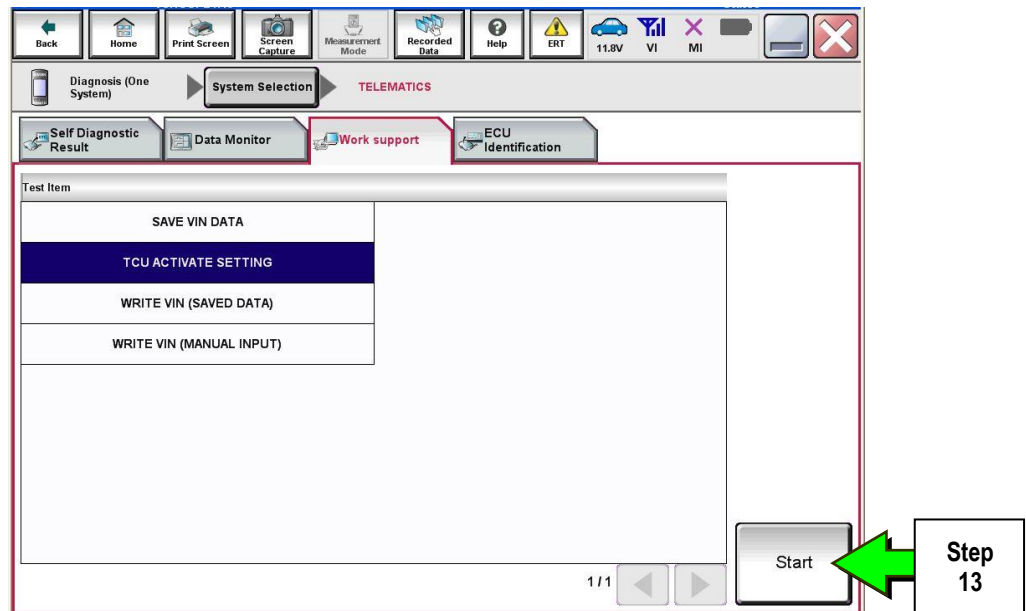

Figure 7

14. Select **Start**.

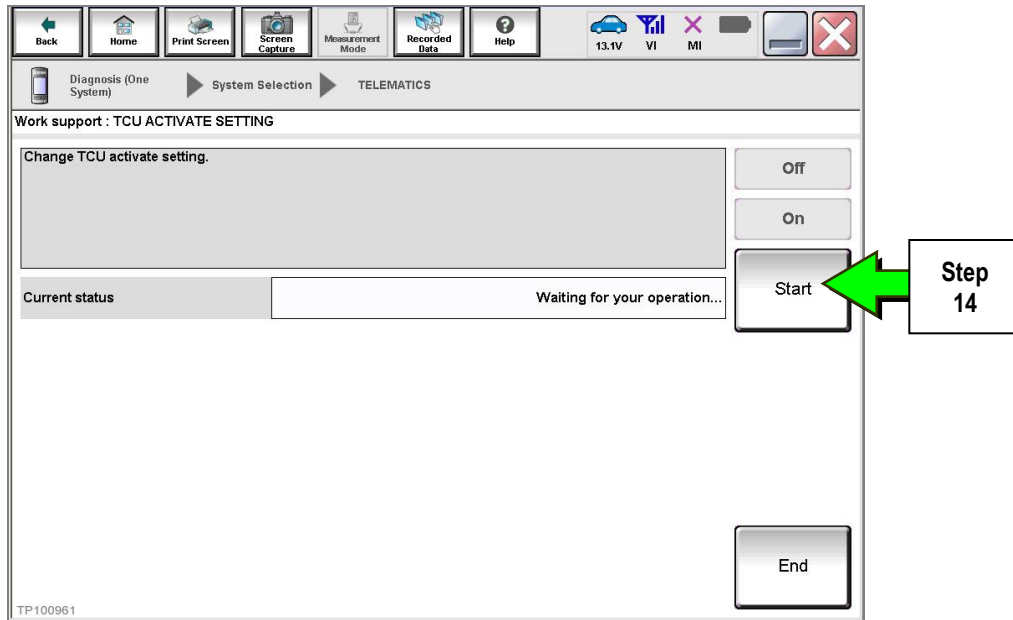

Figure 8

15. Confirm "**Off**" is displayed in the **Current status** field.

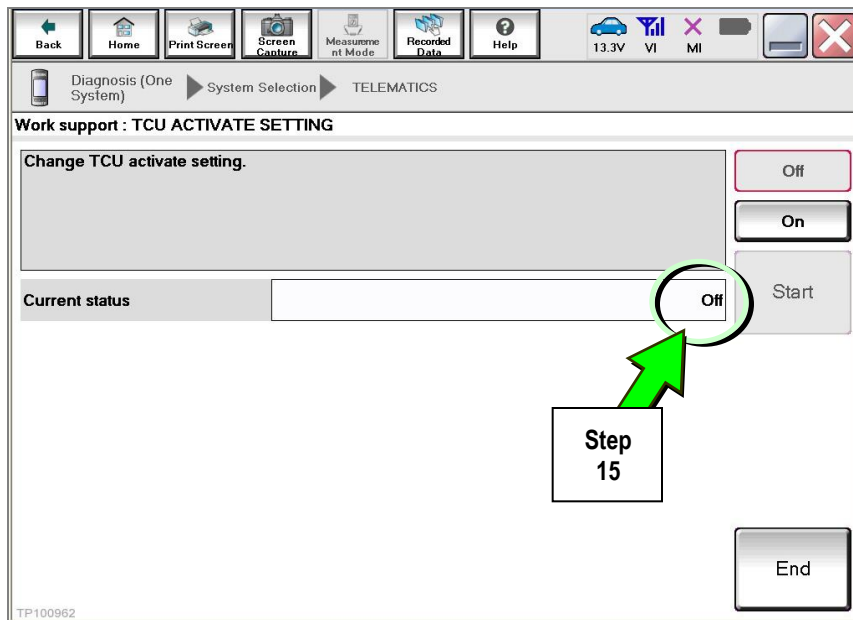

Figure 9

Save VIN Data

1. Select **SAVE VIN DATA**.
2. Select **Start**.

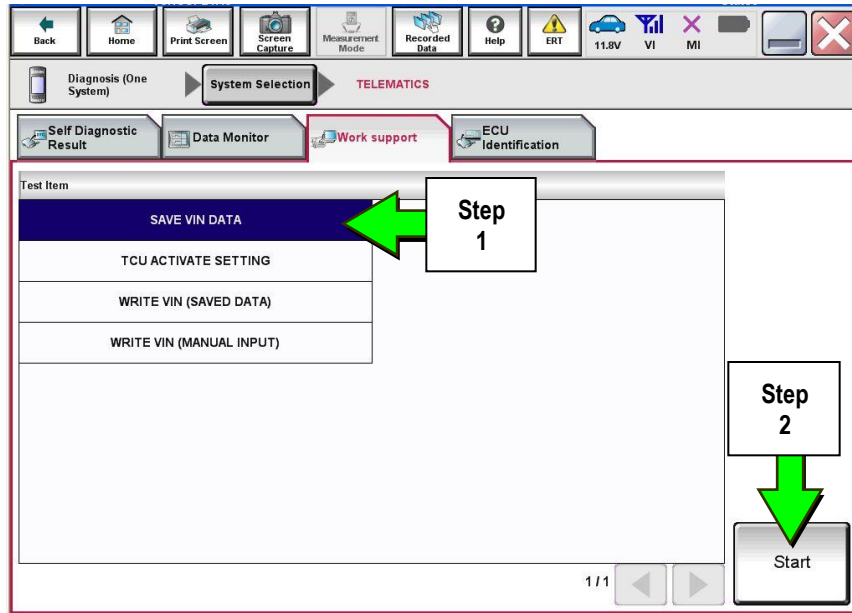

Figure 10

3. Select **Start**.

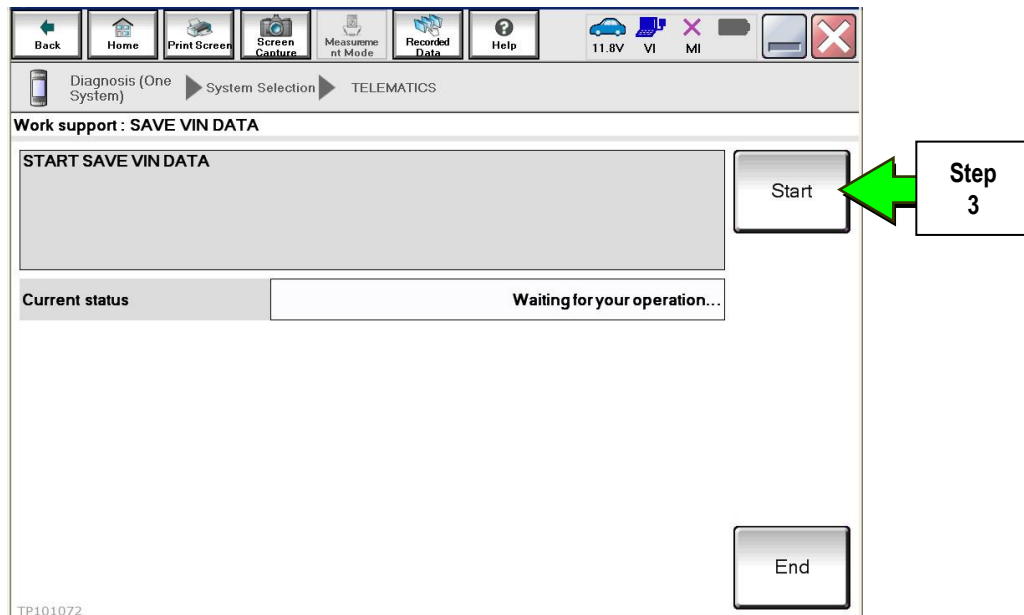

Figure 11

4. Select End.

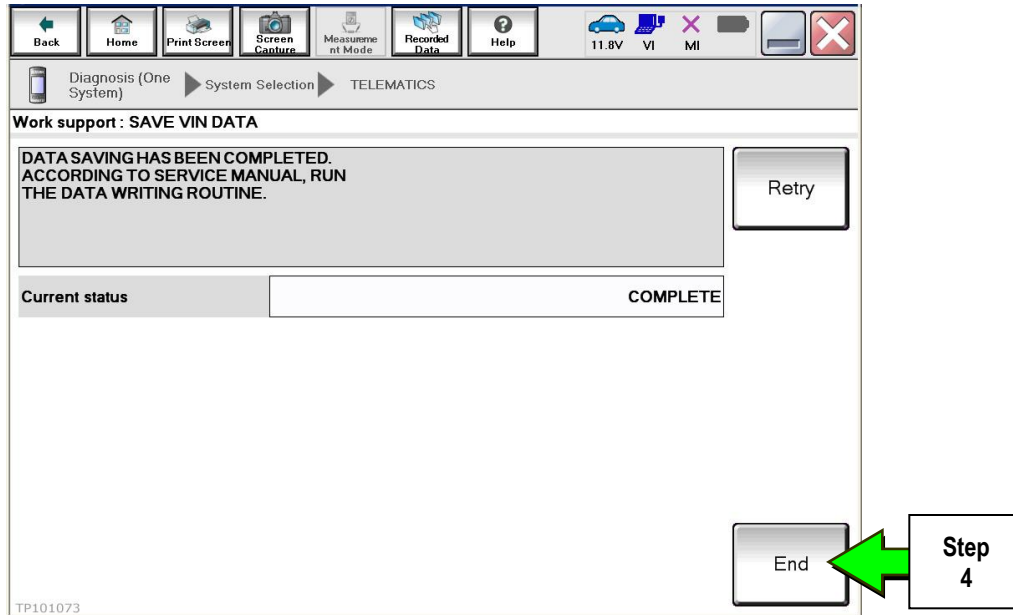

Figure 12

Remove the TCU from the Vehicle.

1. Remove instrument lower cover.
 - a. Pull disengaged pawls downward.
 - b. Pull back instrument lower cover.
 - c. Disconnect harness connectors.

△ : Pawl

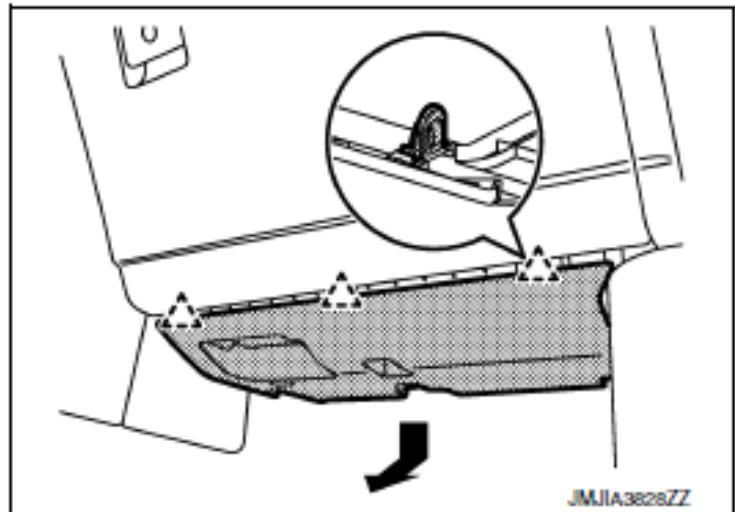



Figure 13

2. Remove glove box assembly.
 - a. Remove glove box assembly fixing screws (A).
 - b. Open glove box lid.
 - c. Remove glove box assembly fixing screws (B).
 - d. Pull back glove box assembly.
 - e. Disconnect harness connector.

 : Pawl
 : Metal clip

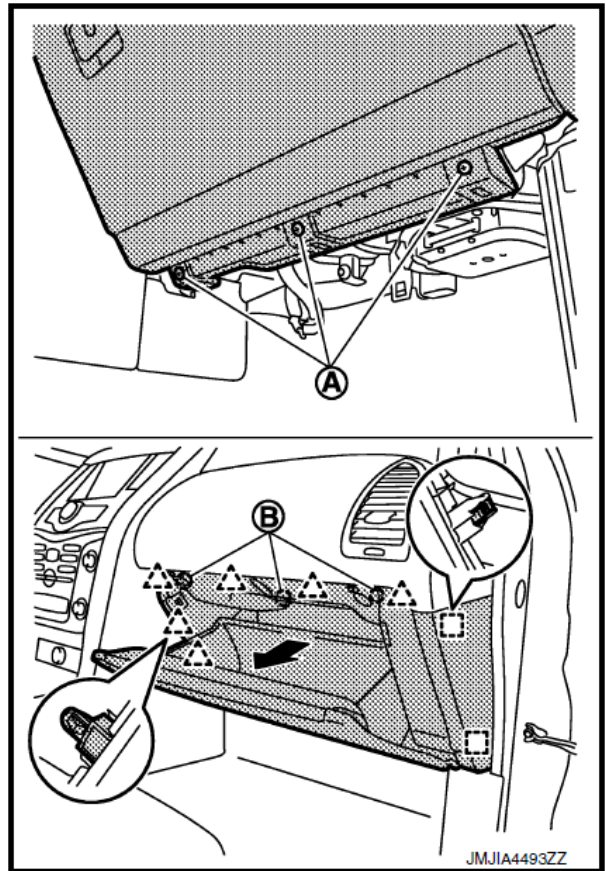
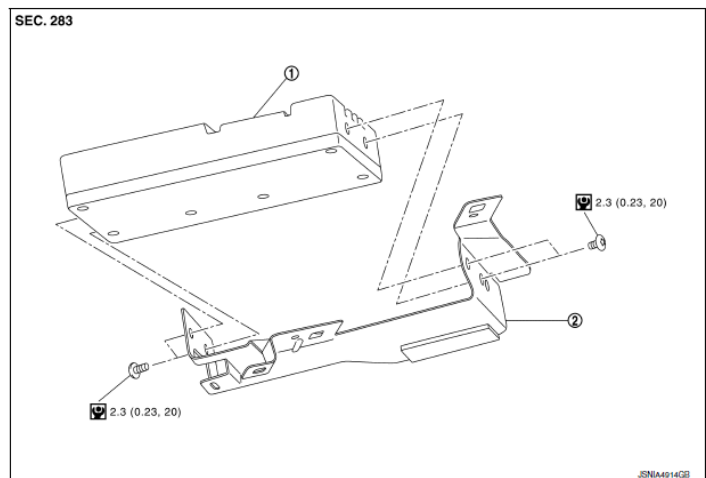



Figure 14

3. Remove the vehicle mounting bolts and disconnect the connector, and then remove them together with the bracket.
4. Remove the bracket mounting screw and remove the bracket from TCU.



1. TCU
 : N·m (kg-m, in-lb)

2. Bracket

Figure 15

Deactivate the Old TCU and then Activate the new TCU

IMPORTANT: Steps 1 and 2 below must be performed AFTER the original TCU is removed from the vehicle and BEFORE the replacement TCU is installed.

1. Collect and have ready the following information:
 - VIN.
 - International Mobile Equipment Identity Number (IMEI) of the original TCU. This number is located on the TCU.
 - IMEI Number of the replacement TCU. This number is located on the TCU.
 - Serial Number of the replacement TCU. This number is located on the TCU.

LABEL ON TCU



Figure 16

2. Call the INFINITI CONNECTION™ Call Center at 1-800-334-7858, press “1” and listen for additional applicable INFINITI retailer prompts to replace a TCU. (Hours of operation are listed at the bottom of the page.)

NOTE: The phone number shown above is for TCU activation and deactivation **ONLY**. The Support Center agent is unable to assist with matters unrelated to TCU activation and deactivation.

During this call:

- You will be asked for your name, dealership name, and all of the information collected in step 1.
- The Support Center agent will deactivate the original TCU and activate the replacement TCU.

IMPORTANT: Step 2 **MUST** be performed to activate the replacement TCU. If it is not performed the TCU will not be able to communicate with the Infiniti Connection Global Data Center.

Infiniti Connection Call Center – Hours of Operation (Central Time Zone)

Monday – Friday: 7AM – 10PM Saturday: 8AM – 5PM

Special Holiday Hours:

Closed Thanksgiving, Christmas, and New Years Day

Christmas Eve: 7AM – 7PM

New Years Eve: 7AM – 7PM

Install Replacement TCU

- Perform steps 1-4 of **Remove the TCU from the Vehicle** procedure starting on page 8, in reverse order, to install.

Turn TCU ON

- Perform steps 1-15 of **Turn OFF the TCU** procedure, starting on page 2, to turn the TCU ON and then confirm the **Current status** field shows “On”.

Write VIN Data

1. Select **WRITE VIN (SAVED DATA)**.
2. Select **Start**.

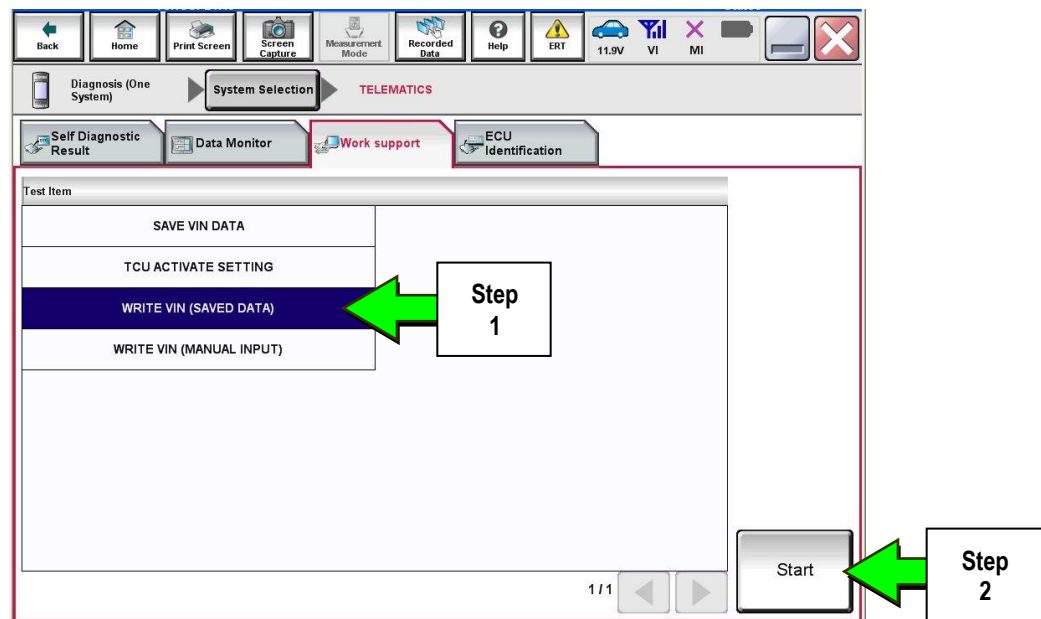

Figure 17

3. Select **Start**.

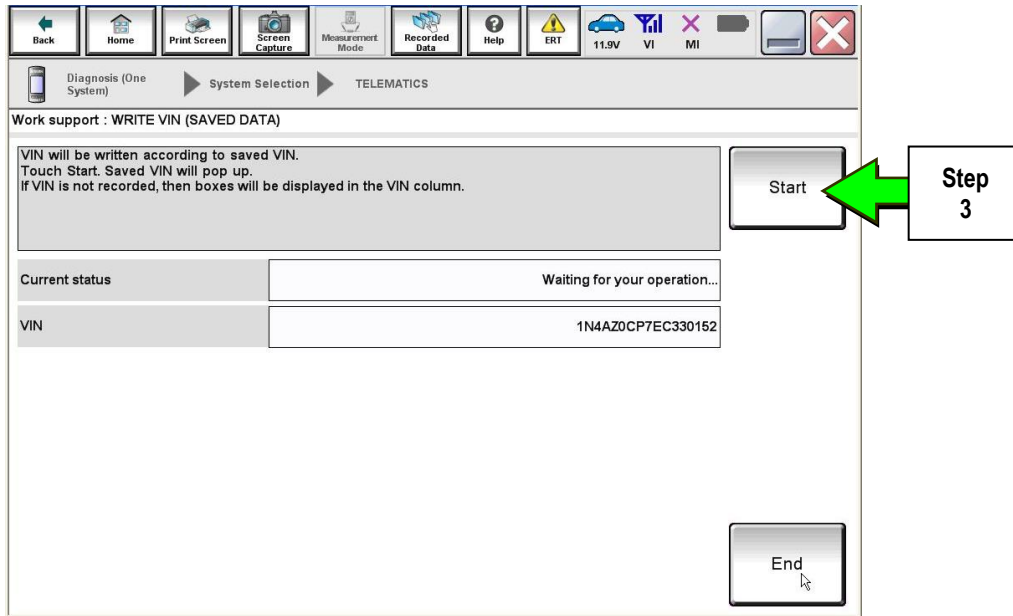

Figure 18

4. Select **End**.

IMPORTANT: Wait at least 2 minutes after the ignition is turned ON before checking for DTCs. If DTCs are checked prior to this a U1000 may be stored.

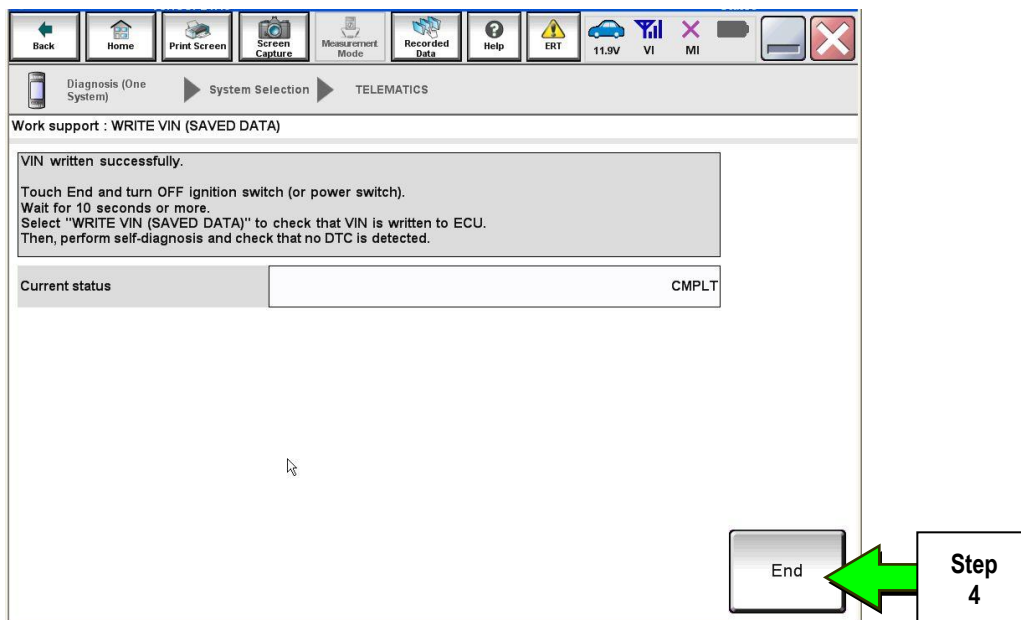

Figure 19

PARTS INFORMATION

Description	PART NUMBER	Quantity
Telematics Control Unit	283B0-3JA5A	1

CLAIMS INFORMATION

Submit a Campaign (CM) line claim using the following claims coding:

CAMPAIGN ("CM") ID	DESCRIPTION	OP CODE	FRT
PC451	Replace Telematics Control Unit (\$299 Co-Pay)	PC4513	1.1 hrs.
PC452	Replace Telematics Control Unit (\$149 Co-Pay)	PC4523	1.1 hrs.
PC454	Replace Telematics Control Unit (Dealer Action Unit – No Co-Pay)	PC4543	1.1 hrs.