

2009-2013 Mazda6 (EQUIPPED WITH 3.7L) WORKSHOP MANUAL ENGINE TIMING CHAIN REMOVAL AND INSTALLATION PROCEDURE CORRECTION

There are two engine timing chain types for the 2009-2013 Mazda6 3.7L.

1. Roller type timing chain is used on the 2009-2011 built before December 14, 2010.
2. Silent type timing chain is used on the 2011-2013 built after December 14, 2010.

Workshop Manual TIMING CHAIN REMOVAL/INSTALLATION [MZI 3.7 V6] has been revised with corrected procedures.

2009-2013 MAZDA6 3.7L - TIMING CHAIN APPLICABILITY

Model Year	Model / Eng.	Production Date	Part Number	Description	Total No. of Links
2009	Mazda6 3.7L	All	CY01-12-201A	Timing Chain (Roller Type)	101
2010					
2011		Built Before Dec. 14, 2010			

Roller Type

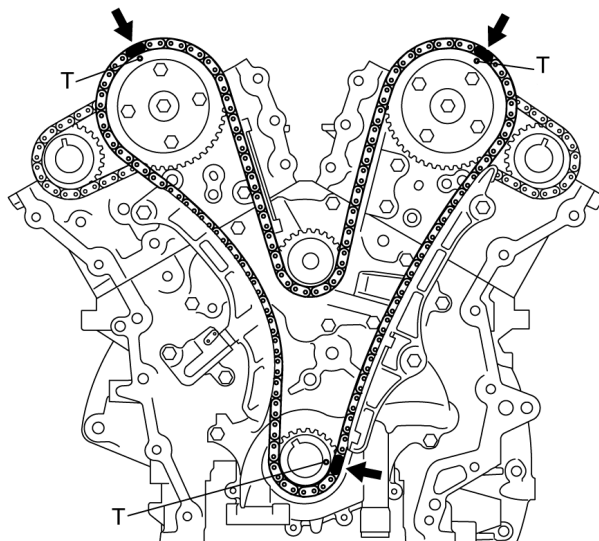

T = Timing Mark

Model Year	Model / Eng.	Production Date	Part Number	Description	Total No. of Links
2011	Mazda6 3.7L	Built After Dec. 14, 2010	CA51-12-201	Timing Chain (Silent Type)	127
2012		All			
2013					

Silent Type

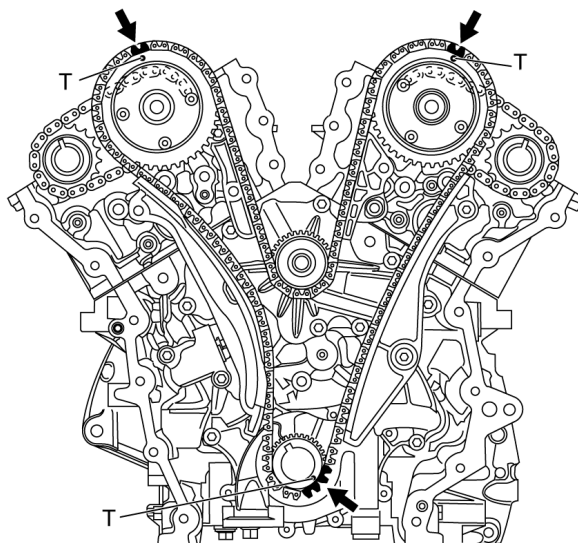

T = Timing Mark

Note:

- Timing chains, crankshaft sprockets, tensioner arms, chain guides, chain tensioners, VVT actuator sets, water pumps, front engine covers and all associated bolts are NOT interchangeable.
- Use GEPC to look up correct part numbers by vehicle Production Date.