

To: All Toyota Dealer Principals, Service Managers, Parts Managers

Subject: Update – Limited Service Campaign 9SM



**This Campaign Expired on December 31, 2012.**

**TECHNICAL INSTRUCTIONS**

**FOR**

**LIMITED SERVICE CAMPAIGN 9SM**

**FOR VEHICLES**

***CURRENTLY REGISTERED IN AND/OR ORIGINALLY SOLD IN***

***AK, AL, AR, AZ, CA, CO, FL, GA, HI, IA, ID, KS, LA, MO, MS, MT, NC,  
ND, NE, NM, NV, OK, OR, SC, SD, TN, TX, UT, WA, and WY***

**REAR FRAME CROSS MEMBER REPLACEMENT**

**ON**

**2000 THROUGH 2003 MODEL YEAR TUNDRA**

**This Campaign Expires  
December 31, 2014**

# I. OPERATION FLOW CHART

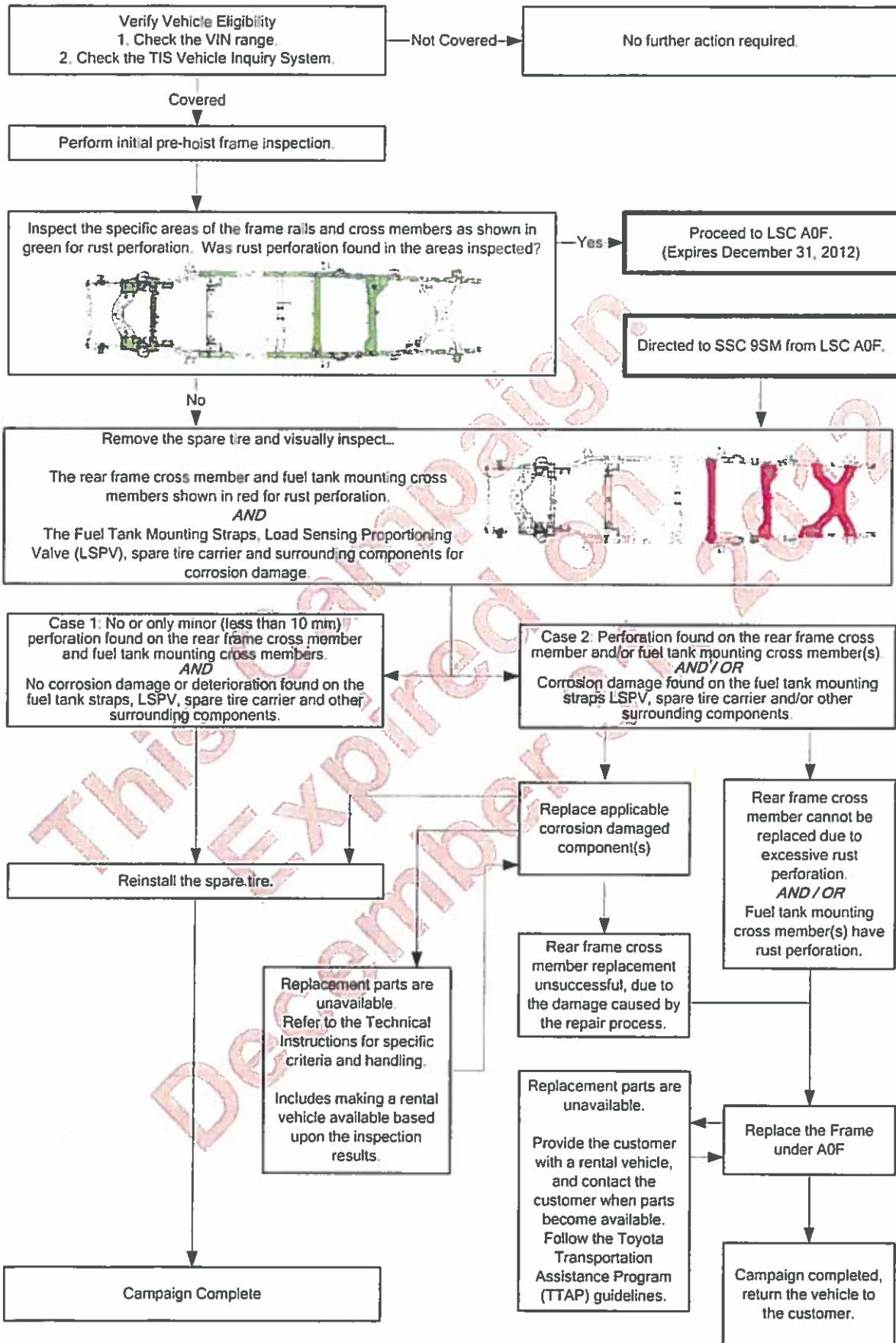

## II. IDENTIFICATION OF AFFECTED VEHICLES

### A. AFFECTED VIN RANGE

Model	WMI	Year	VIN Range	
			VDS	Range
Tundra	5TB	2000	BN441	S001001 - S124211
			BN481	S001001 - S001001
			BT441	S001001 - S125901
			BT481	S001001 - S125894
			JN321	S001001 - S125878
			KN421	S001001 - S001003
			KN441	S001001 - S051314
			KT441	S001001 - S125833
			RN341	S001001 - S125859
			RN381	S001001 - S001003
			RT341	S001001 - S125904
			RT381	S001001 - S125897
		2001	BN441	S127099 - S220170
			BT441	S125911 - S220327
			BT481	S064335 - S220350
			JN321	S126112 - S220343
			KN441	S064852 - S064852
			KT421	S090565 - S090565
			KT441	S125953 - S220297
			RN341	S125909 - S220341
			RT341	S125907 - S220347
		2002	RT381	S064333 - S220345
			BN441	S220461 - S332258
			BT441	S220352 - S332710
			BT481	S219295 - S332685
			JN321	S220351 - S332714
			KT441	S220754 - S332680
			RN341	S220353 - S332719
			RT341	S220360 - S332721
			RT381	S220365 - S332666
		2003	BN441	S332744 - S434008
			BT441	S316368 - S439612
			BT481	S306031 - S439593
			JN321	S332750 - S436914
			KT441	S330788 - S439601
			RN341	S307943 - S436915
RT341	S306032 - S439732			
RT381	S308386 - S439716			

#### NOTE:

- Check the TIS Vehicle Inquiry System to confirm the VIN is covered by this Limited Service Campaign, and that the campaign has not already been completed prior to dealer shipment or by another dealer.
- TMS warranty will not reimburse dealers for repairs conducted on vehicles that are not covered or were completed by another dealer.

### III. BACKGROUND

- Toyota has received reports that certain 2000 through 2003 model year Tundra vehicles operated in cold climate areas with high road salt use, may exhibit excessive corrosion on the rear cross member and the fuel tank mounting system.
- Exposure to cold climate and high road salt usage conditions are primary contributors. This is unrelated to, and separate from, normal surface rust which is commonly found on metallic surfaces after some years of usage and/or exposure to the environment.

### IV. VEHICLE INSPECTION WORK PROCEDURE

#### A. INITIAL PRE-HOIST FRAME INSPECTION

##### 1. INSPECT THE FRAME FOR RUST PERFORATION

- If NG (rust perforation found), use a drive on vehicle lift to inspect the frame & cross members. **DO NOT lift vehicle by the frame.**
- If OK (no rust perforation), you may use a frame contacting vehicle lift to inspect the frame & cross members.

##### 2. VISUALLY INSPECT THE FRAME AND CROSS MEMBERS

- Visually inspect the specific areas (highlighted in green) of the frame assembly as shown for visible signs of perforation.

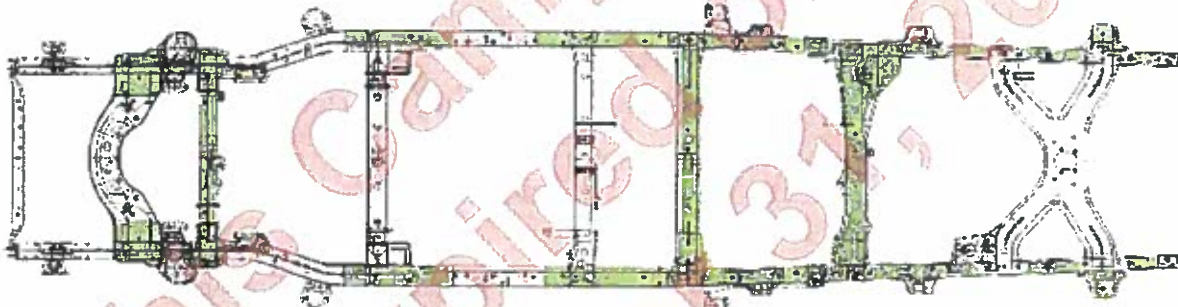

Judgement Criteria	Result	Action
Perforation (hole) of 10 mm or more	NG	<ul style="list-style-type: none"> <li>• Replace the frame under A0F</li> </ul>
Perforation (hole) of less than 10 mm	OK	<ul style="list-style-type: none"> <li>• No action required</li> <li>• Proceed to Rear Cross Member Inspection</li> </ul>

#### B. INSPECT THE REAR FRAME CROSS MEMBER

##### 1. REMOVE THE SPARE TIRE AND INSPECT THE REAR FRAME CROSS MEMBER FOR RUST PERFORATION

Judgment Criteria	Result	Action
A perforation (hole) of over 10 mm	NG	Replace the rear frame cross member <i>For part number information, please reference Section V "Parts Information"</i>

**C. INSPECT THE FUEL TANK MOUNTING STRAPS, LSPV, SPARE TIRE CARRIER AND SURROUNDING COMPONENTS**

**1. INSPECT THE FUEL TANK STRAPS FOR CORROSION DAMAGE**

- a) Using a piece of cloth, clean the outside surface of the front and rear fuel tank mounting straps to remove any dirt and debris.
- b) Inspect the outside surface of the fuel tank mounting straps, does the rust span the width (front to rear) of either fuel tank strap as shown.

**Inspection Area:**

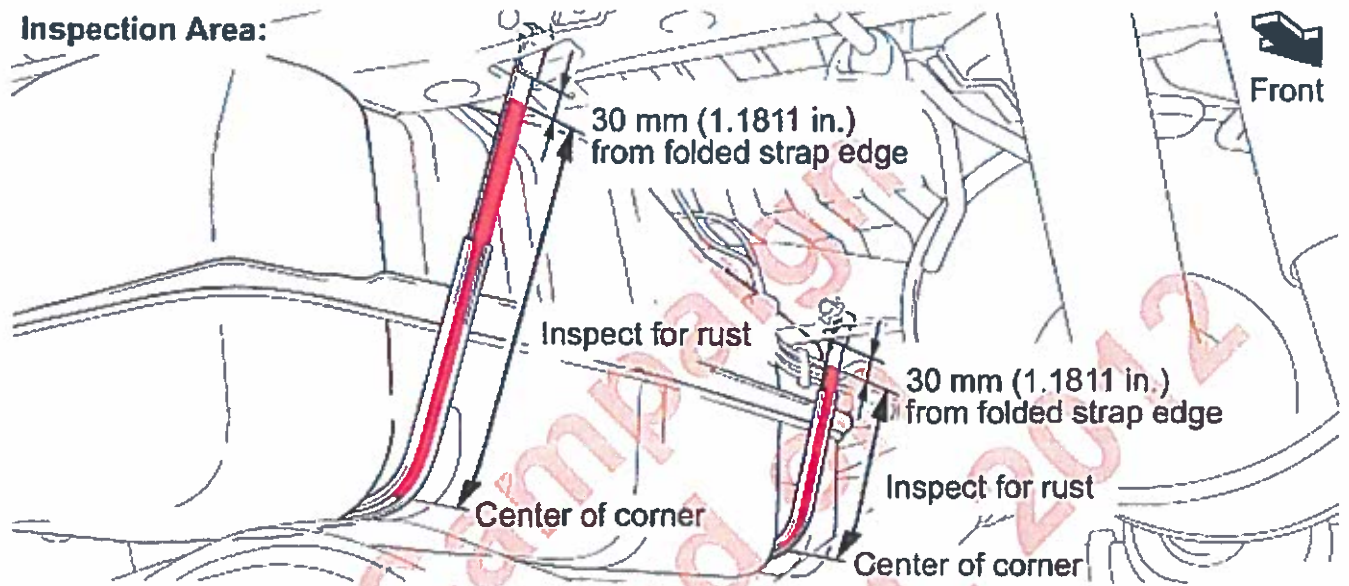

**Inspection Standard:**

Rusting occurs continuously along the entire width of the strap.

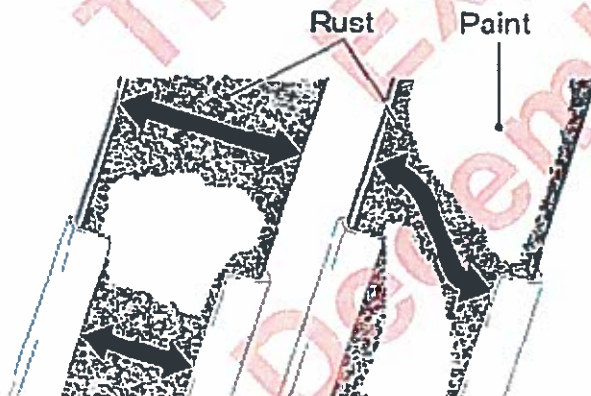

**NG**

Rusting does not occur continuously along the entire width of the strap.

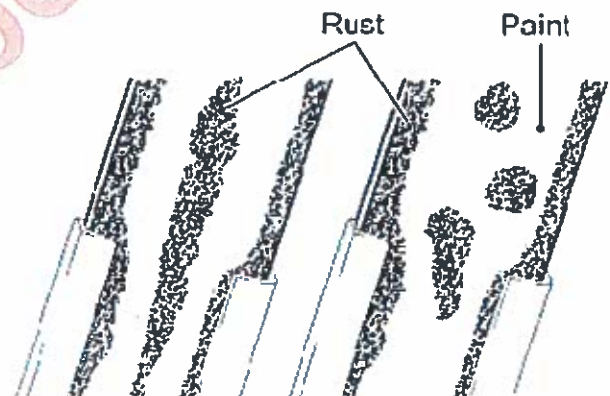

**OK**

Judgment Criteria	Action
NG	Replace the fuel tank strap(s) <i>For part number information, please reference Section V "Parts Information"</i>
OK	Replacement not required

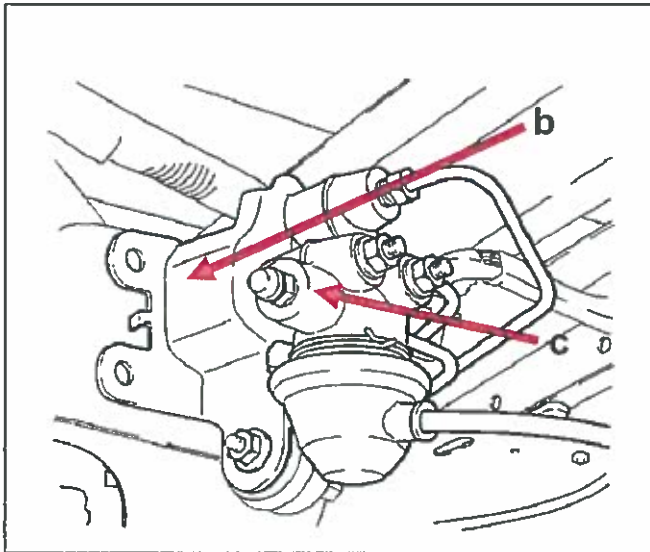

## 2. INSPECT THE LSPV

- a) If there are signs of excessive rust and brake fluid leakage on the LSPV, replace the damaged parts.
- b) With one hand using minimal force, attempt to wiggle the valve bracket (b).
  - If the valve bracket is loose, replace the damaged part.
- c) With one hand using minimal force, attempt to wiggle the valve body (c).
  - If the valve body and/or associated components are loose or show any signs of leakage, replace the damaged parts.

For part number information, please reference Section V "Parts Information"

## 3. INSPECT THE SPARE TIRE CARRIER FOR DETERIORATION

- a) Inspect the spare tire carrier lift plate as shown.

Judgment Criteria	Result	Action
Deterioration Found	NG	Replace the spare tire carrier For part number information, please reference Section V "Parts Information"
No Deterioration	OK	Replacement not required

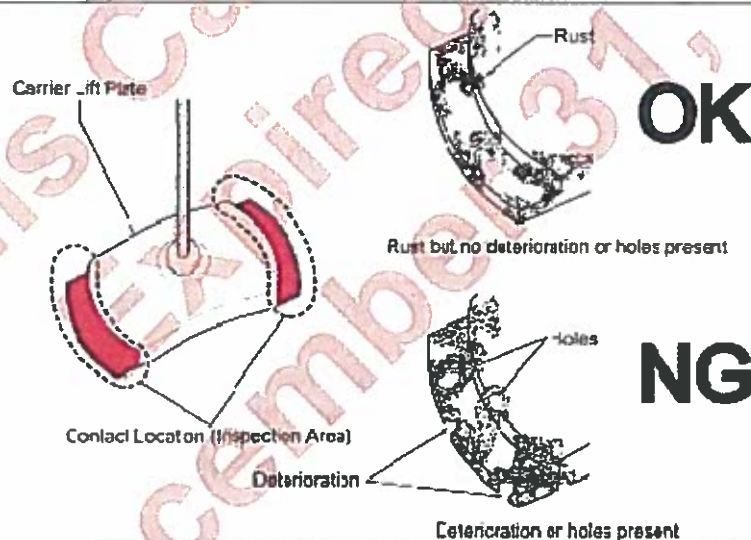

## 4. INSPECT SURROUNDING COMPONENTS AND ADJACENT AREAS

- a) Inspect the...

- Brake lines
- Fuel line
- Exhaust pipe brackets
- Steering components and power steering lines
- Suspension mounts

**NOTE:** If there is perforation, breakage, and/or fluid leakage of the specified components or adjacent areas due to corrosion replace the damaged part(s).



- If parts are NOT available for the components requiring replacement (i.e. brake components, fuel lines, LSPV, spare tire carrier, etc.) inform the customer and provide them with a rental vehicle. Contact the customer when parts become available.
- Follow the Toyota Transportation Assistance Program (TTAP) guidelines for rentals.

## V. PARTS INFORMATION

### • Rear Frame Cross Member

MY	Description	Part Number	Part Name	Qty
2000 – 2002	-	51209-0C010	Rear Frame Cross Member Sub-assembly	1
2003	-	51209-0C012	Rear Frame Cross Member Sub-assembly	1
All	-	90080-11288	Bolt	13
All	-	90178-A0082	Nut	13

### • Fuel Tank Straps

MY	Description	Part Number	Part Name	Qty
2000	2WD	77601-34030	Fuel Tank Strap Sub-assembly No.1	1
		77603-34070	Fuel Tank Strap Sub-assembly No.2	1
	4WD	77601-34040	Fuel Tank Strap Sub-assembly No.1	1
		77603-34060	Fuel Tank Strap Sub-assembly No.2	1
2001 – 2003	2WD <i>Except UCK30 Off Road Package</i>	77601-34030	Fuel Tank Strap Sub-assembly No.1	1
		77603-34070	Fuel Tank Strap Sub-assembly No.2	1
	4WD <i>Includes UCK30 Off Road Package</i>	77601-34040	Fuel Tank Strap Sub-assembly No.1	1
		77603-34060	Fuel Tank Strap Sub-assembly No.2	1

### • Load Sensing Proportioning Valve (LSPV)

MY	Description	Part Number	Part Name	Qty
2000 – 2002	WO/ABS	47910-34060	LSPV Assembly	1
2000 – 2003	W/ABS	47910-34070	LSPV Assembly	1

### • Spare Tire (Wheel) Carrier

MY	Description	Part Number	Part Name	Qty
All	-	51900-0C010	Spare Wheel Carrier Assembly	1

#### NOTE:

- Depending on the vehicle condition, additional parts may be required.
- Correct part number(s) should be confirmed with the parts catalog.

## VI. REAR FRAME CROSS MEMBER REPLACEMENT WORK PROCEDURE

### A. TOOLS & EQUIPMENT

- Air hammer with...
  - Flat chisel bit
  - Tapered punch bit
- Dust mask
- Ear plugs
- Frame expansion bar\*
- Protective eyewear
- Protective work gloves
- Standard hand tools
- Steel tape measure
- Torque wrench
- Torx ® T55H Tamper Resistant Socket
- Pencil Type Grinder – 1/8" Chuck
- Cone Shaped Grinding Stone

\*NOTE: One Frame Expansion Bar will be provided to each region covering: AK, AL, AR, AZ, CA, CO, FL, GA, HI, IA, ID, KS, LA, MO, MS, MT, NC, ND, NE, NM, NV, OK, OR, SC, SD, TN, TX, UT, WA, and WY

### B. MATERIALS

- Black paint (chassis black or black anti-corrosive paint)
- Sandpaper 80 grit



C. COMPONENTS

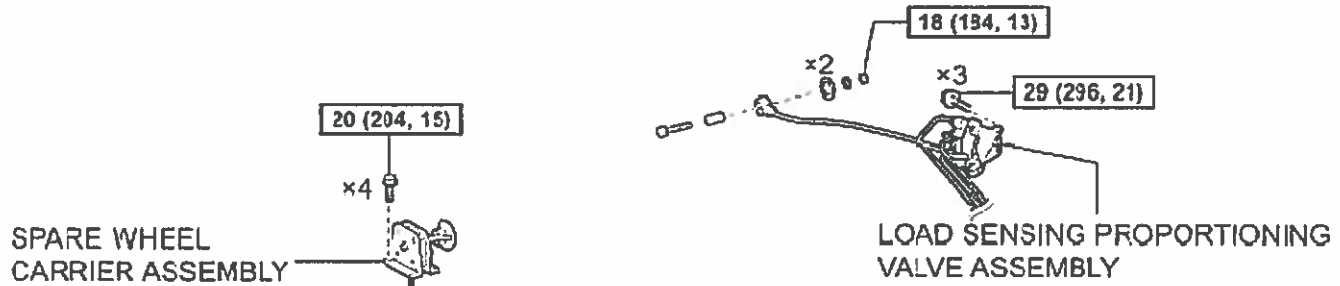

**NOTE:**  
Please follow all work procedure instructions and notes when tightening the bolts and nuts.  
54 (551, 40)

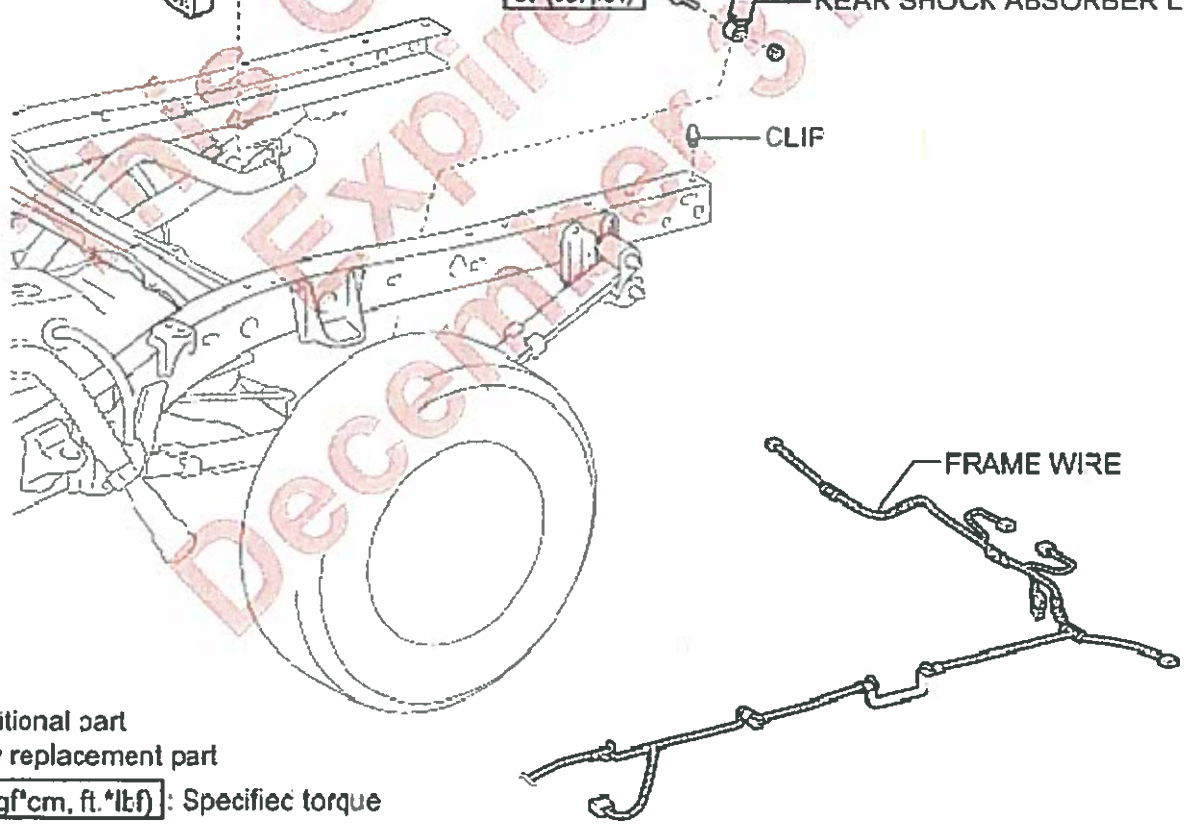
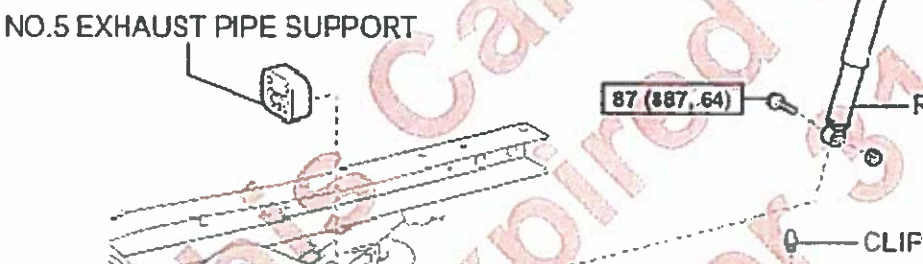
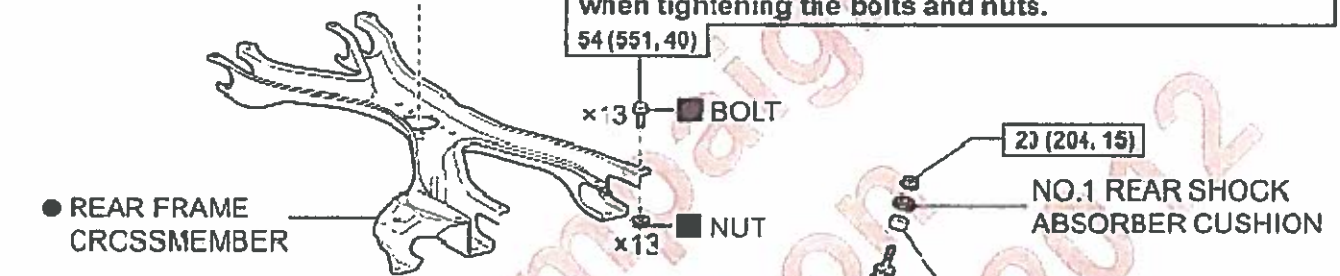

■ Additional part  
● New replacement part  
N\*m (kgf\*cm, ft.\*lbf): Specific torque

#### D. LOCATION AND TORQUE SPECIFICATIONS FOR SURROUNDING COMPONENTS IF REPLACED

Location reference diagram and torque values for replacing brake harness and LSPV.

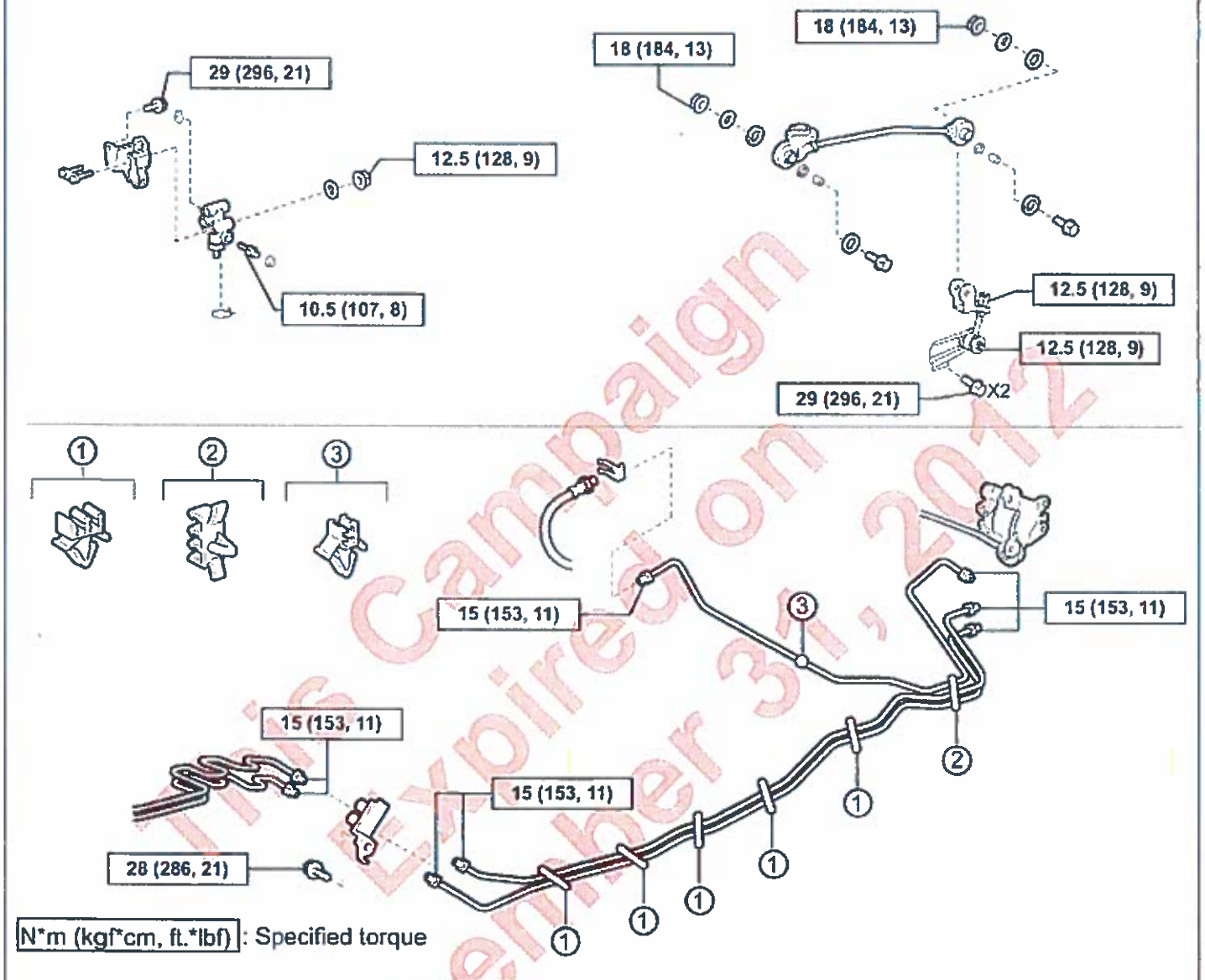

#### E. REAR FRAME CROSS MEMBER REMOVAL

1. REMOVE THE LICENSE PLATE LIGHTS
2. REMOVE THE CENTER REAR BUMPER PAD
3. REMOVE THE REAR BUMPER ASSEMBLY
4. REMOVE THE TRAILER HITCH (IF EQUIPPED)

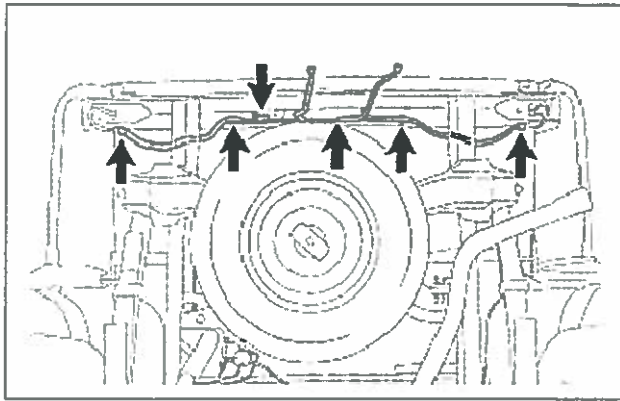

#### 5. DISCONNECT THE FRAME WIRE HARNESS

- a) Disconnect the connectors.
- b) Disconnect the clips and the frame wire harness from the bed assembly.

#### NOTE:

- The number of connectors may differ depending on the vehicle specification.
- Be careful not to damage the wire harness clips when removing them.

#### 6. REMOVE THE REAR MUDGUARDS (IF EQUIPPED)

#### 7. REMOVE THE FUEL TANK FILLER PIPE SHIELD

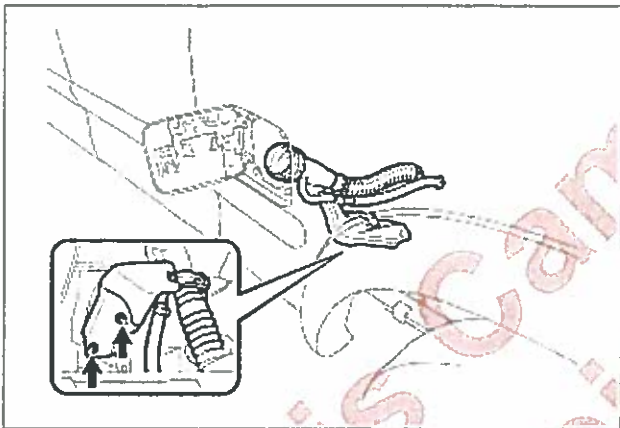

#### 8. DISCONNECT THE FUEL INLET PIPE

- a) Remove the 2 nuts and disconnect the fuel inlet pipe.

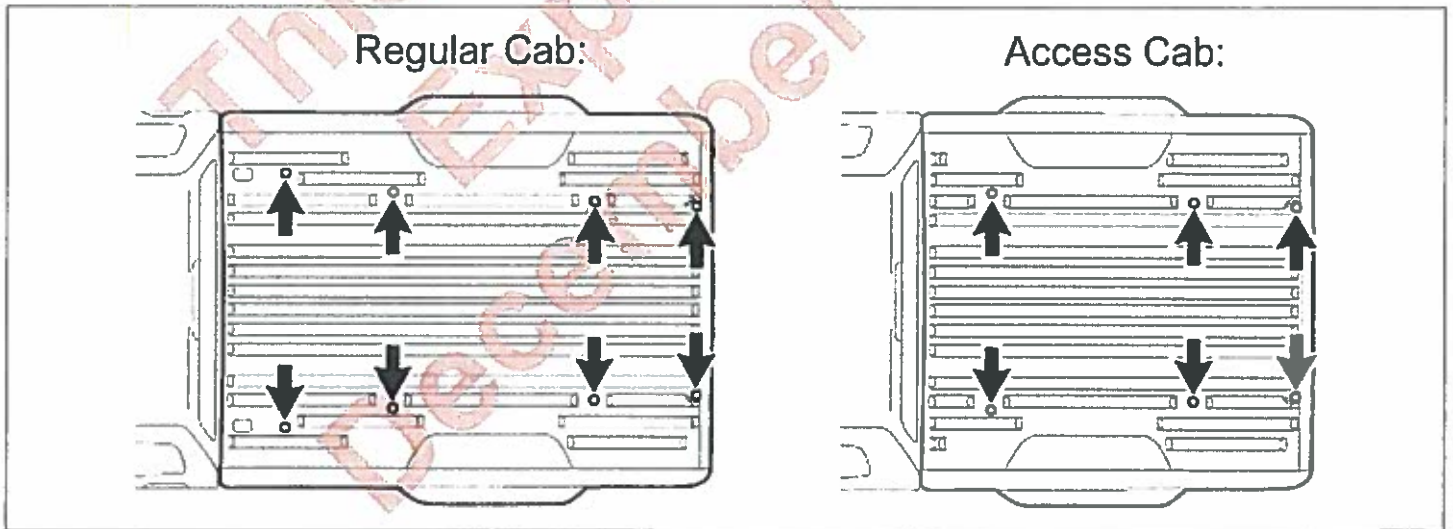

#### 9. REMOVE THE BED ASSEMBLY

- a) Using a Torx ® T55H Tamper Resistant Socket, remove the Torx ® bolts from the bed assembly
  - Regular Cab: 8 Torx ® bolts
  - Access Cab: 6 Torx ® bolts

#### NOTE:

- Use 4 or more people to remove the bed assembly from the frame.
- Evenly support the bed assembly when removing it.

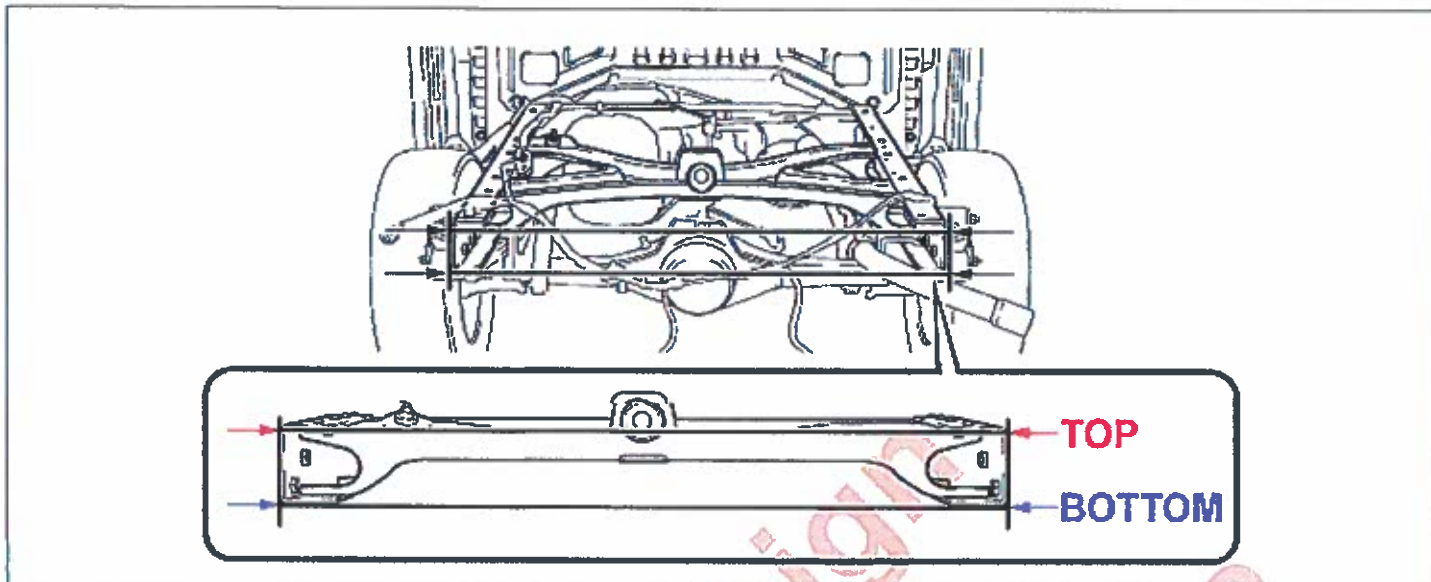

**10. MEASURE THE DIMENSIONS OF THE REAR FRAME END**

- a) Measure and record the distance between the left and right frame rails for the **TOP** and **BOTTOM** edges of the rear frame end as shown.

**TOP:** \_\_\_\_\_ **BOTTOM:** \_\_\_\_\_

**NOTE:**

Make sure to measure and record the distances. These measurements will be used for adjustment purposes after the cross member has been installed.

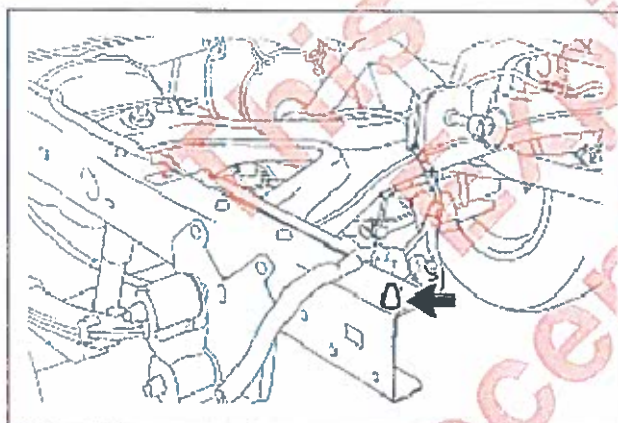

**11. REMOVE THE CLIP**

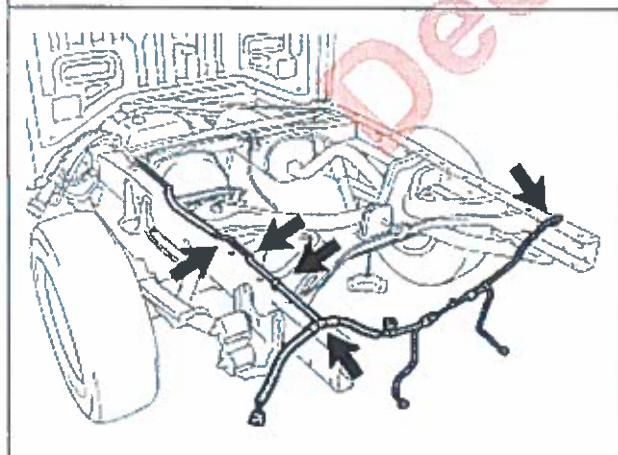

**12. DISCONNECT THE FRAME WIRE HARNESS**

- a) Remove the 5 wire harness clips.

**NOTE:**

**DO NOT** damage the wire harness clip during removal.

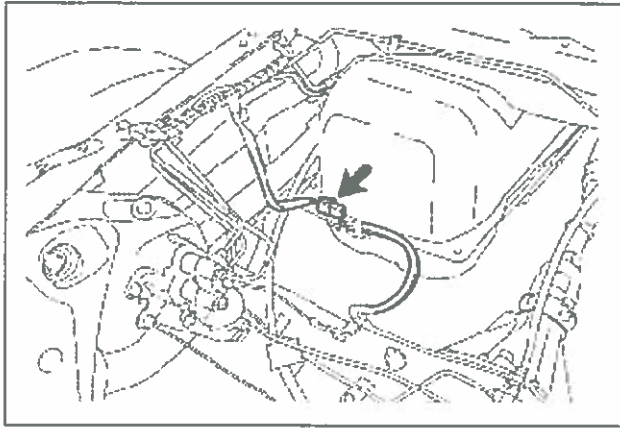

b) Disconnect the ABS connector (*if equipped*).

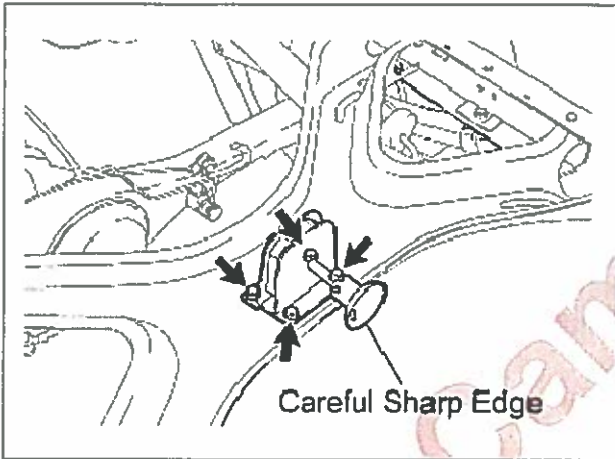

### 13. REMOVE THE SPARE TIRE CARRIER

a) Remove the 4 bolts and the spare tire carrier.

**NOTE:**

The edge of the spare tire carrier is sharp, take care when removing.

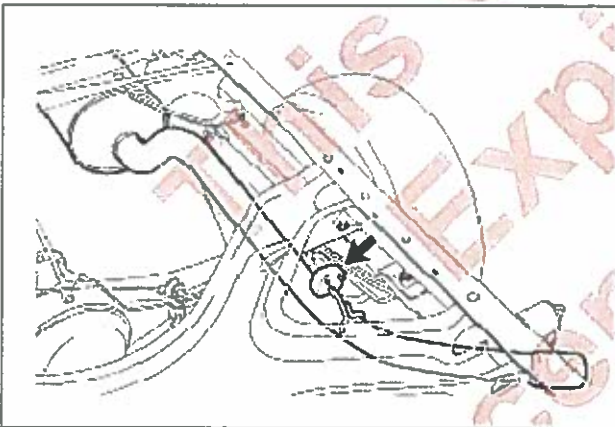

### 14. REMOVE THE EXHAUST PIPE HANGER

a) Remove the exhaust pipe hanger from the frame.

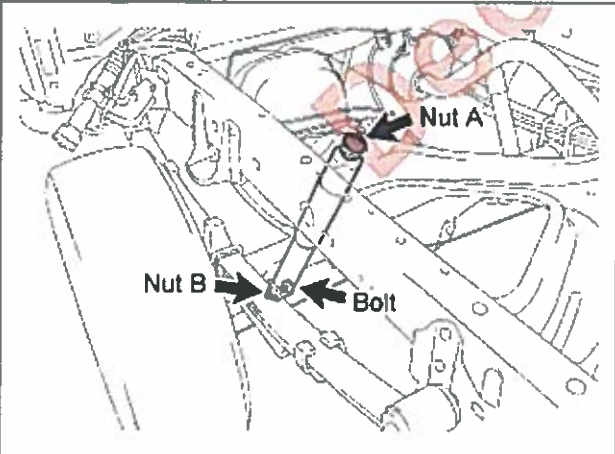

### 15. REMOVE THE REAR SHOCK ABSORBER LH

a) Remove the 2 nuts, bolt and the rear shock absorber LH.

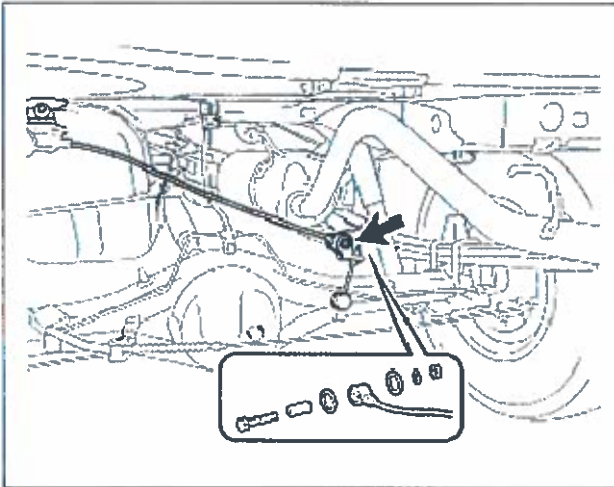

## 16. DISCONNECT THE LSPV AND LOAD SENSING SPRING

- a) Remove the nut, washer and bolt, and then disconnect the load sensing spring.
- b) Remove the 2 washers and collar from the load sensing spring to prevent them from falling off.

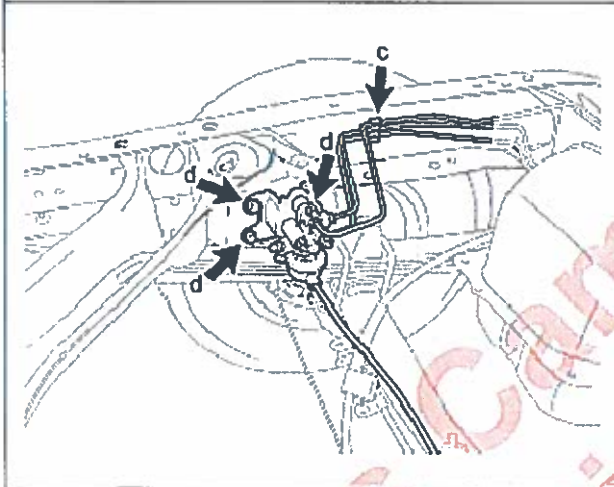

- c) Disconnect the brake line clip.
- d) Remove the 3 bolts and disconnect the LSPV assembly.

### NOTE:

- DO NOT damage the brake line clip during removal.
- Visually inspect the LSPV for any damage of fluid leakage. Replace the LSPV if damage or fluid leakage is found.



- e) Suspend the LSPV with a rope this will protect the brake lines from damage and deformation.



- When using an air chisel and air hammer wear protective eyewear, ear plugs and gloves.
- Please have ALL personnel near the work area wear ear plugs when the air chisel and air hammer are in use.

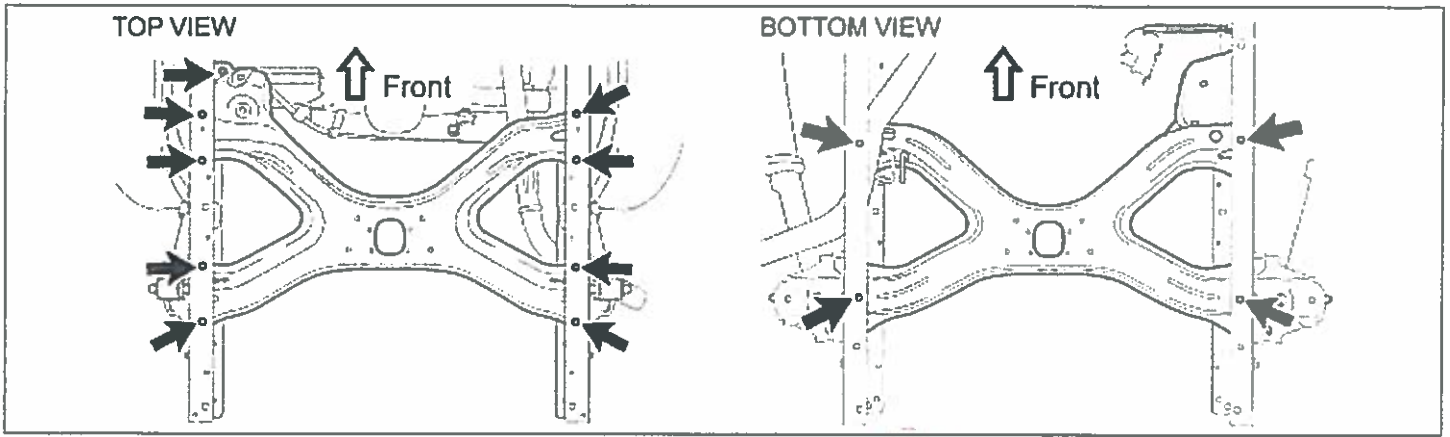

**17. REMOVE THE REAR FRAME CROSS MEMBER**

- a) Using an air chisel cut off the 13 rivet heads.

**NOTE:**

- Always wear protective eyewear, ear plugs and gloves when using an air chisel and air hammer.
- DO NOT allow personnel near the vehicle, as the rivet heads may fly off when cut.
- Cover the cab body to prevent damage from flying debris.

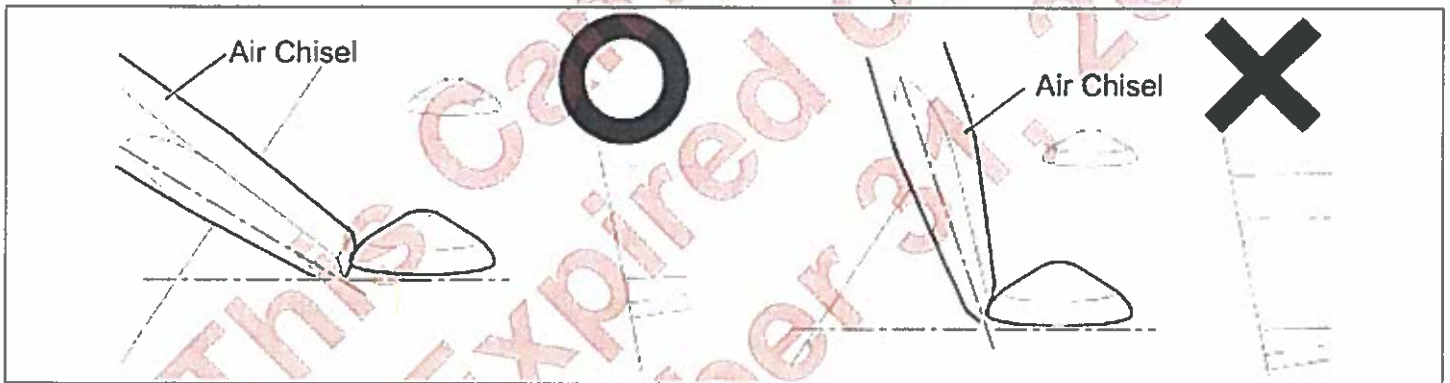

- b) Position the air chisel in between the rivet and side member. DO NOT increase the angle the air chisel, doing so may damage frame side member.

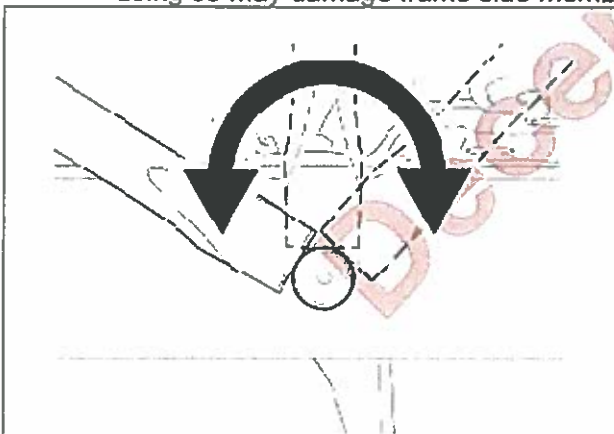

- c) When cutting the rivet head, alternate the position of the air chisel between 3 to 4 different spots.

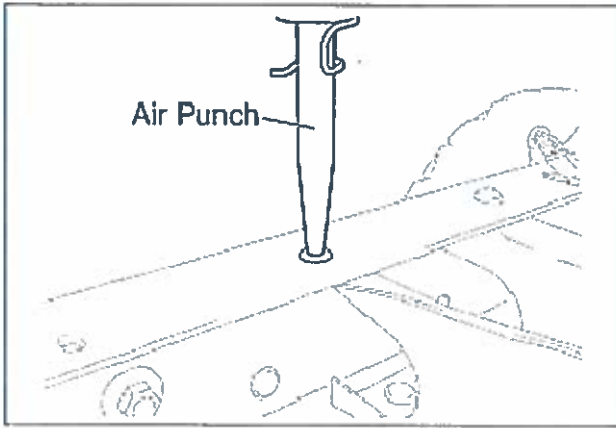

d) Using an air punch remove the 13 rivets.

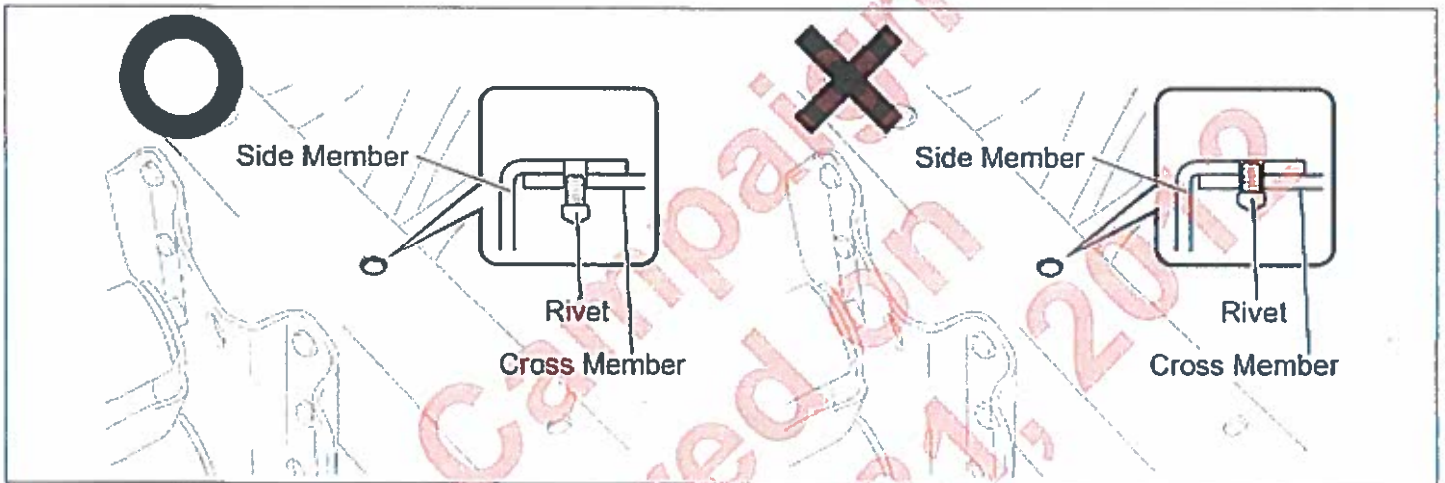

e) The rivet may expand preventing removal with the air punch.

- If the rivet is attached only to the cross member no further action is required.
- If the rivet is attached to the side and cross member, drill a hole in the rivet. Then use a hammer and punch to knock the rivet out.

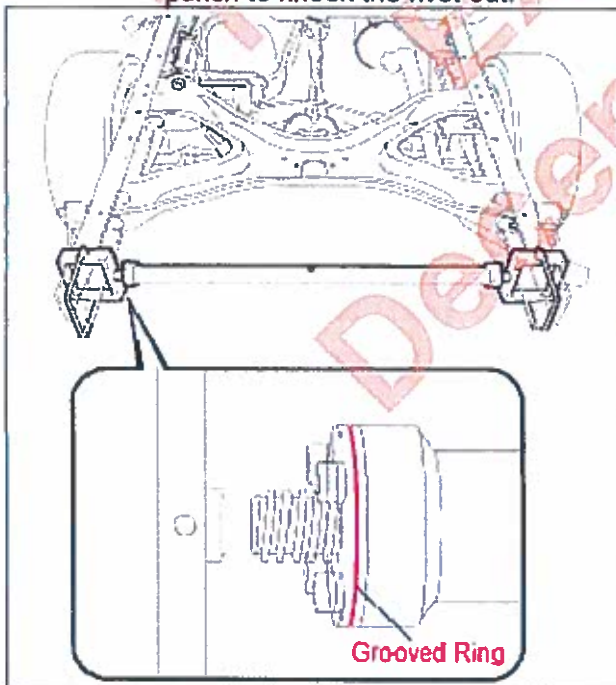

f) Set the frame expansion bar on the vehicle with the groove ring on the left side of the vehicle.

**NOTE:**

- Verify that the threaded section of the frame expansion bar is properly greased.
- If grease is needed, apply disulfide molybdenum grease to the threaded section before use.



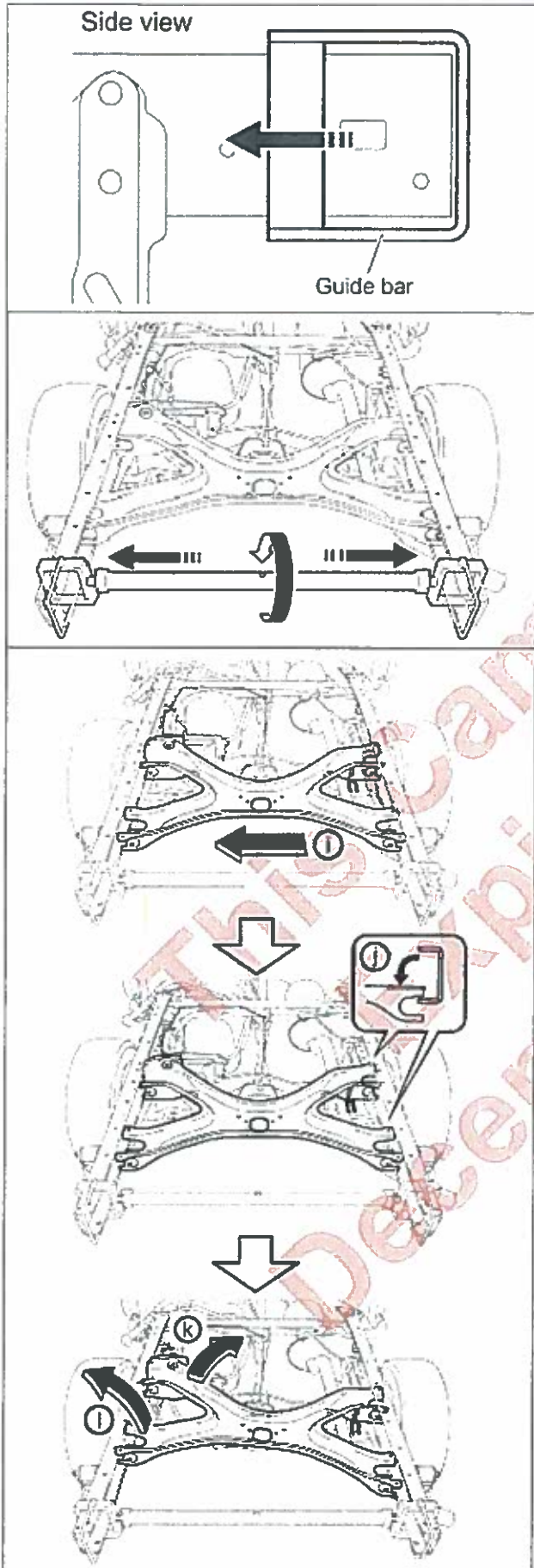

- g) Push the expansion bar until both guide bars contact the frame.
- h) Using the frame expansion bar, expand the ends of the frame rails by 4.33 in. (110 mm).
- i) Push the rear frame cross member towards the left of the vehicle as shown.
- j) Lower the right side of the rear frame cross member one notch as shown.
- k) From the left side of the vehicle, slightly twist the rear frame cross member to the right and lift up to remove as shown.

**NOTES:**

- Use 2 people to remove the rear frame cross member.
- DO NOT remove the expansion bar.

## F. REAR FRAME CROSS MEMBER INSTALLATION

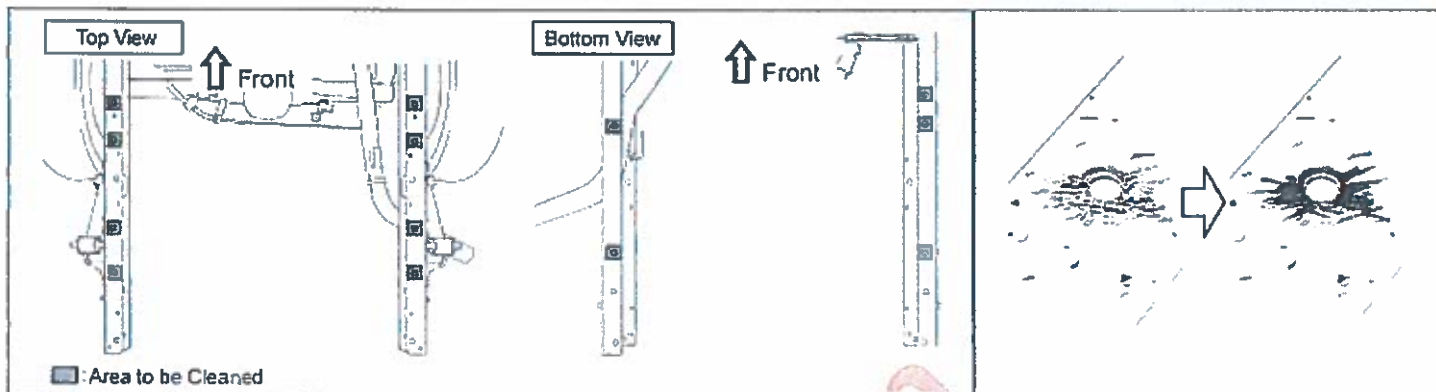

### 1. PREPARE AND CLEAN THE BOLT MOUNTING SURFACE

- a) Using 80-grit sandpaper, remove any scratches and uneven areas from where the rivets were removed.
- b) Sand the surfaces until they are smooth and even.

#### NOTE:

- Any unevenness in the surface can cause the bolts to loosen.
- Make sure the surface is completely even before proceeding to the next step.

This Campaign  
Expired on  
December 31, 2012

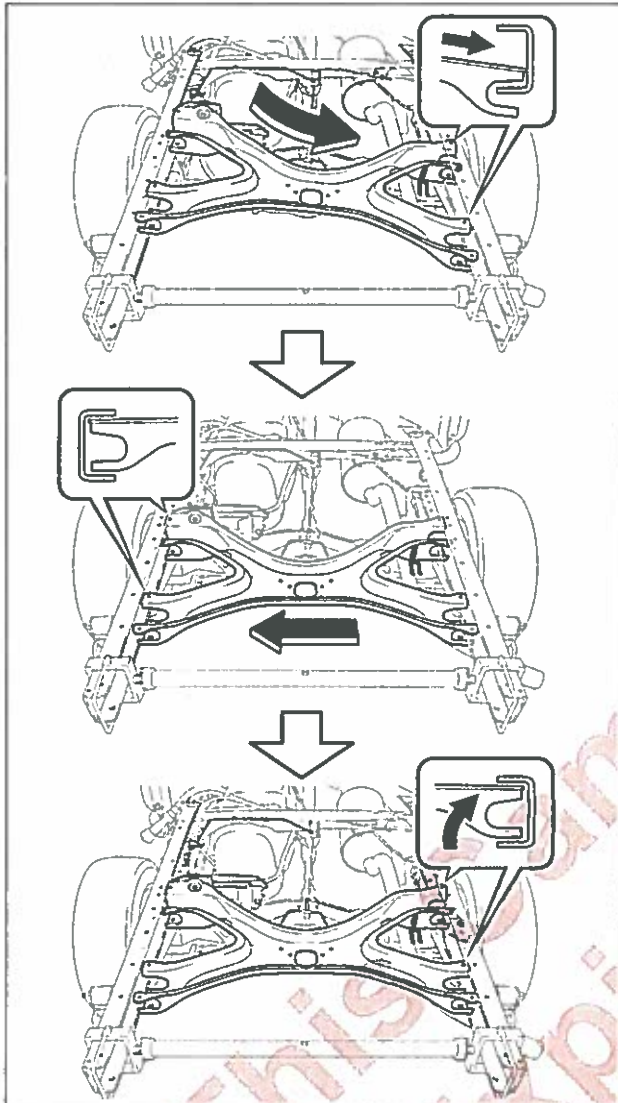

## 2. INSTALL THE **NEW** FRAME REAR CROSS MEMBER

- a) From the left side of the vehicle, insert the **NEW** rear frame cross member and set the right notches in the position shown.

### NOTES:

Use 2 people to install the **NEW** rear frame cross member.

- b) Slightly twist the **NEW** frame rear cross member and set the left side in the side member as shown.

- c) Push the **NEW** frame rear cross member towards the left and set the right side in the side member as shown.

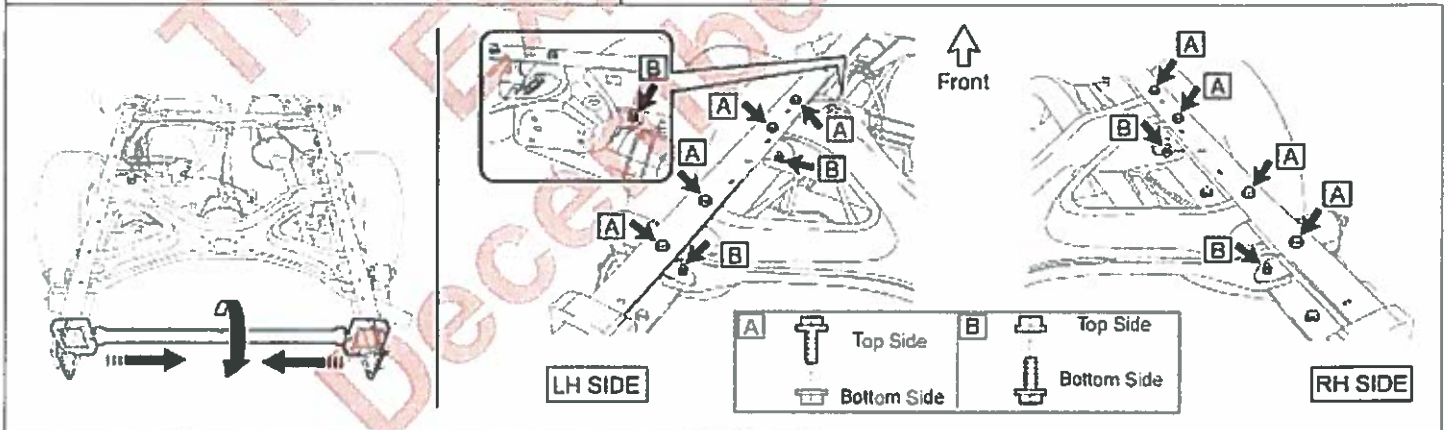

## 3. INSTALL THE BOLTS AND NUTS

- a) While shortening the frame expansion bar, align the side member and cross member holes and temporarily install 13 **NEW** bolts and nuts.

### NOTES:

- DO NOT fully tighten the bolts and nuts at this time.
- For the lower section of the side member, insert the bolts from the bottom side.

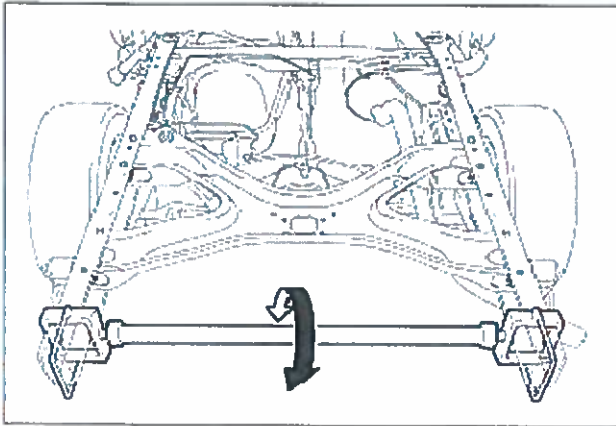

- b) After temporarily installing the bolts and nuts, measure the distance between the left and right frame rails for the **TOP** and **BOTTOM** edges of the rear frame end.
- c) Compare the new measurements to the ones taken in step "9. MEASURE THE DIMENSIONS OF THE REAR FRAME END" during rear frame cross member removal process, and adjust the frame expansion bar until they match.

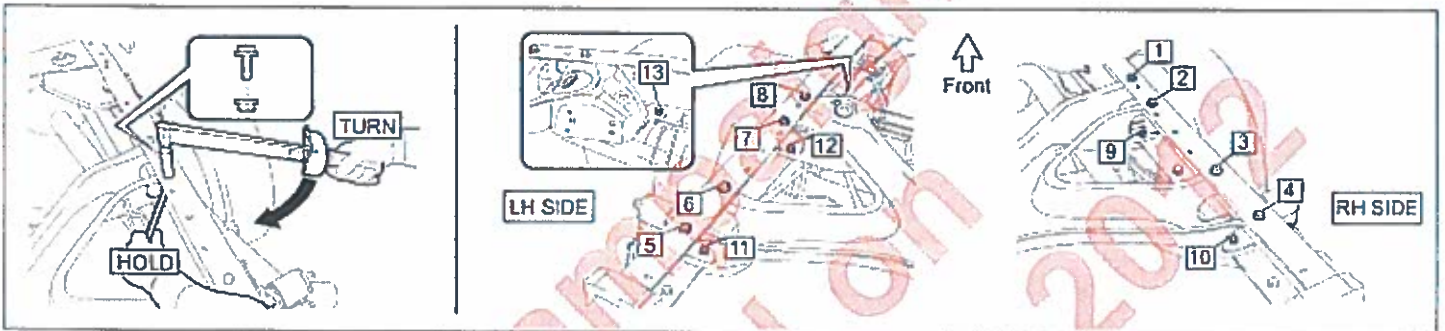

#### 4. TIGHTEN THE BOLTS AND NUTS

- a) In the order illustrated, **tighten each bolt to specification while holding the nut.**

**Torque Specification: 54 N·m (551 kgf·cm, 40 ft·lbf)**

**NOTE:**

- **DO NOT** tighten the nut.
- **Tighten the bolt while holding the nut.**

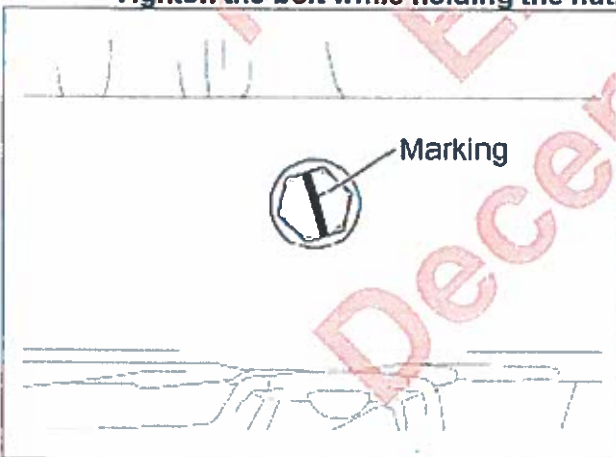

- b) Mark the tightened bolts as shown for verification.
- c) Remove the frame expansion bar.

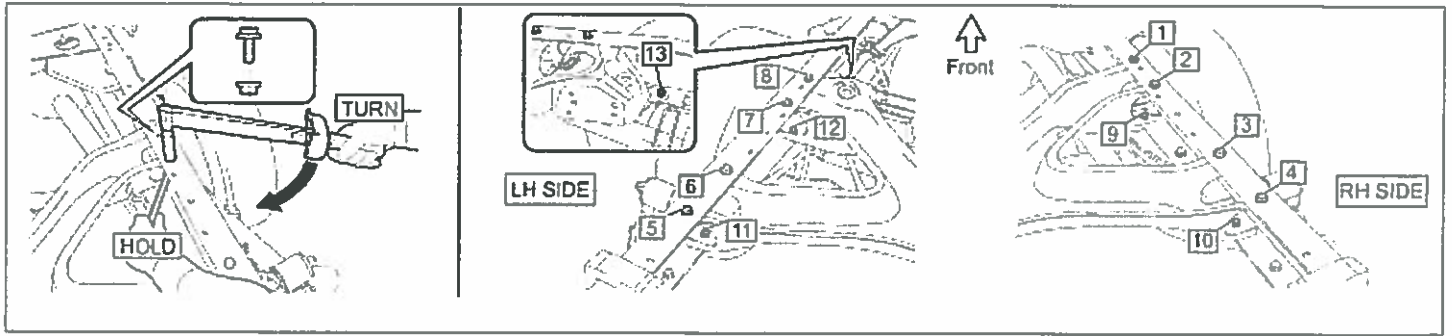

## 5. RETIGHTEN THE BOLTS AND NUTS

- a) In the order illustrated, retighten each bolt to specification while holding the nut.

Torque Specification: 54 N·m (551 kgf·cm, 40 ft·lbf)

### NOTE:

- DO NOT tighten the nut.
- Tighten the bolt while holding the nut.

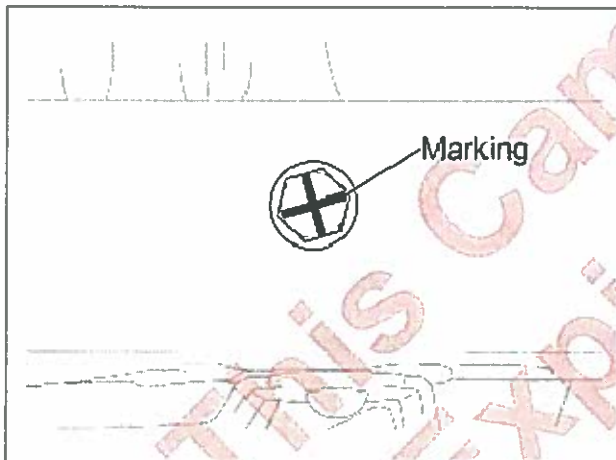

- b) Mark the tightened bolts as shown for verification.  
 c) Verify that every bolt has an X mark on the head.

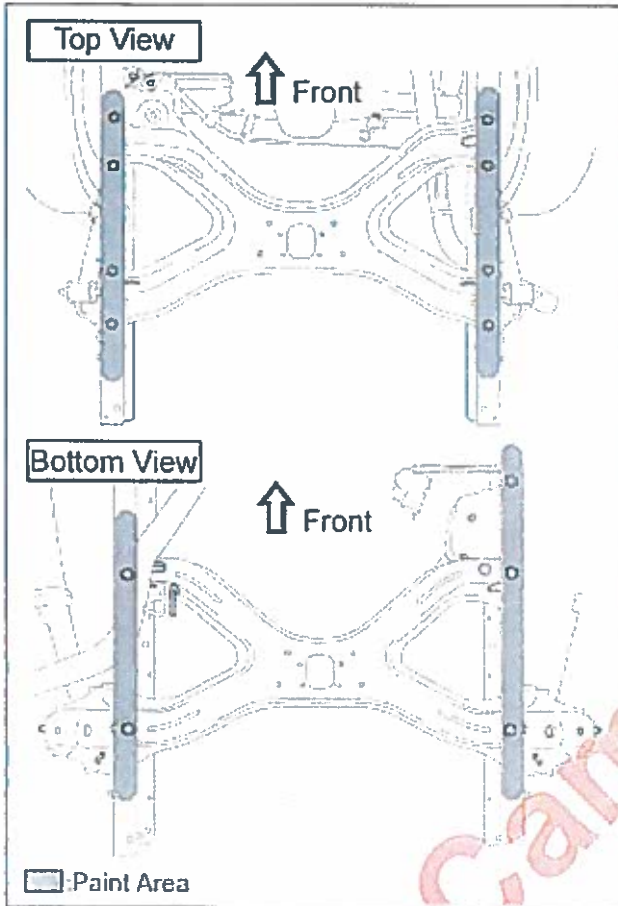

- d) Apply paint (chassis black or black anti-corrosive paint) to the top and bottom areas on the side member as shown.

**NOTE:**

Confirm all the bolts are tightened before applying paint to the side member.

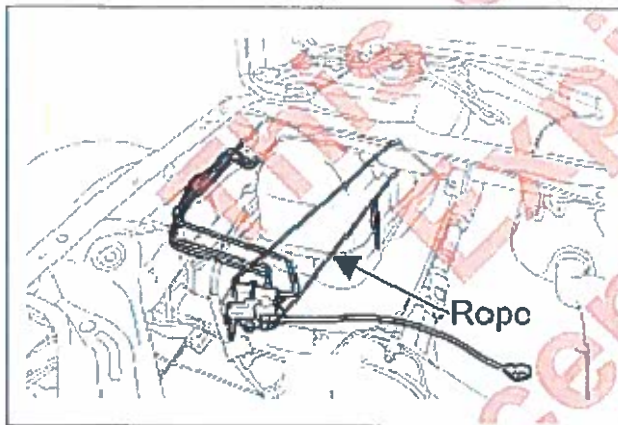

**6. RECONNECT THE LSPV AND LOAD SENSING SPRING**

- a) Remove the rope supporting the LSPV.

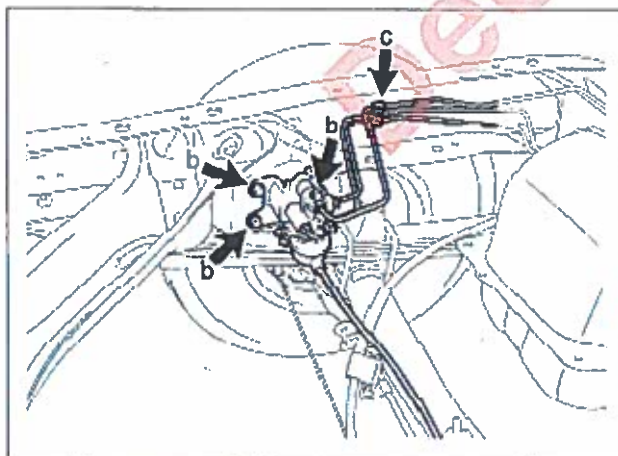

- b) Reinstall the LSPV with the 3 bolts and tighten to specification.

**Torque Specification: 29 N·m (296 kgf·cm, 21 ft·lbf)**

- c) Reconnect the brake line clip.

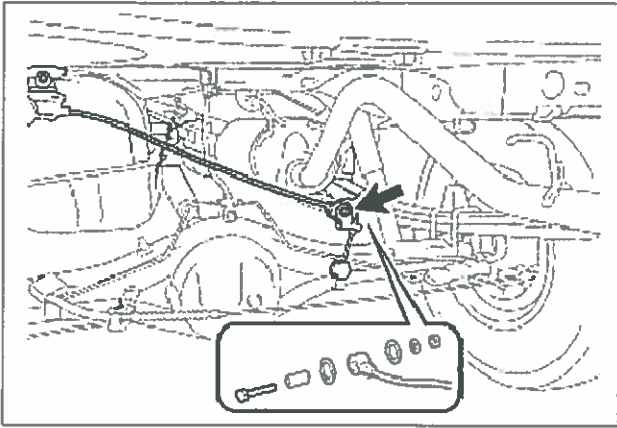

- d) Reinstall the collar and 2 washers to the load sensing spring.
- e) Reinstall the load sensing spring with the bolt, washer and nut, and then tighten to specification.

**Torque Specification: 18 N·m (184 kgf·cm, 13 ft·lbf)**

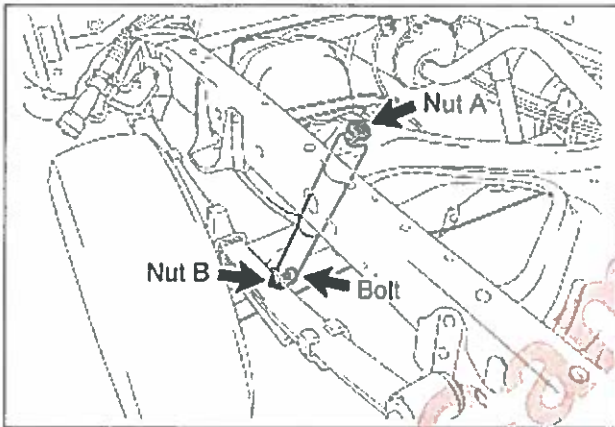

#### 7. REINSTALL THE REAR SHOCK ABSORBER LH

- a) Reinstall the rear shock absorber LH with the bolt and 2 nuts, and tighten to specification.

**Torque Specification:**

**Bolt – 87 N·m (887 kgf·cm, 64 ft·lbf)**

**Nut A– 20 N·m (204 kgf·cm, 15 ft·lbf)**

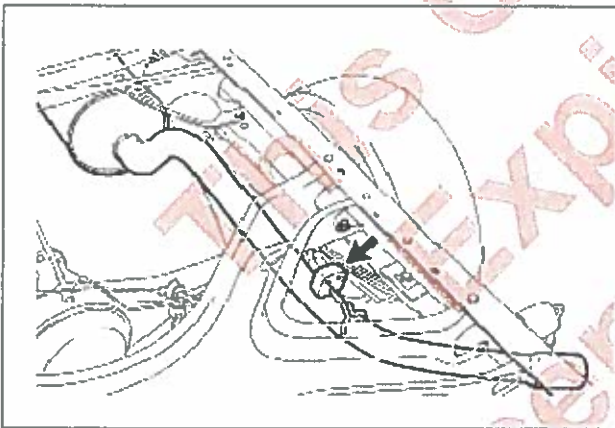

#### 8. REINSTALL THE EXHAUST PIPE HANGER

- a) Reinstall the exhaust pipe hanger to the frame.

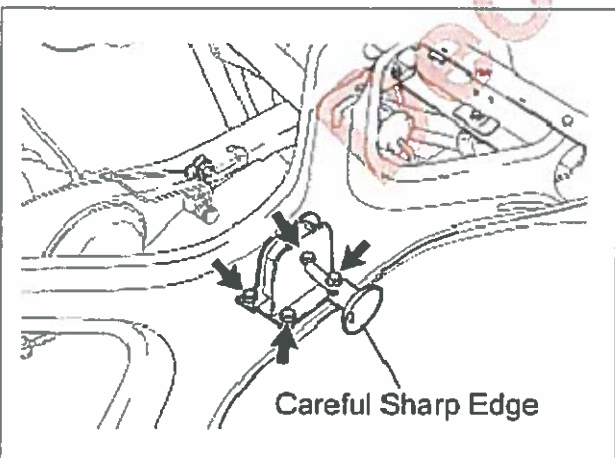

#### 9. REINSTALL THE SPARE TIRE CARRIER

- a) Reinstall the spare tire carrier with the 4 bolts, and tighten to specification.

**Torque Specification: 20 N·m (204 kgf·cm, 15 ft·lbf)**

**NOTE:**

The edge of the spare tire carrier is sharp, take care when installing.

## 10. REPLACE THE FUEL TANK STRAPS

- a) Remove the bolt, clip, pin and the fuel tank strap.
- b) Support the fuel tank prior to removing the strap.

### NOTE:

If the fuel tank strap bolt and weld nut breaks or cannot be removed, reference the APPENDIX for additional information on fuel tank weld nut and bolt replacement.

- c) Install the **NEW** fuel tank strap with the pin, clip and bolt, then torque to spec.

**Torque Specification: 62 N·m (632 kgf·cm, 46 ft·lbf)**

- d) Repeat the procedure on the other fuel tank strap.



## 11. RECONNECT THE FRAME WIRE HARNESS

- a) Reconnect the ABS connector (*if equipped*).

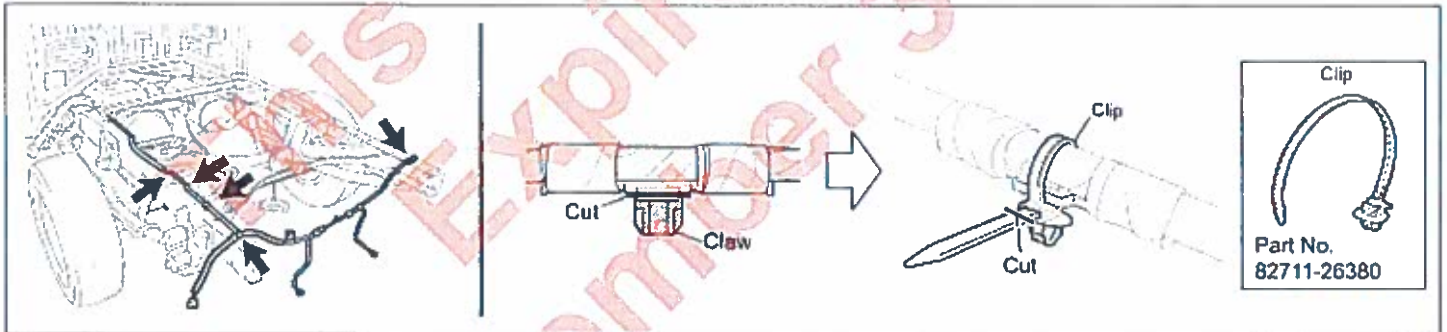

- b) Reinstall the 5 wire harness clips.

### NOTE:

If the clip(s) indicated for the frame wire harness is damaged or broken, cut off the damaged claw and replace it with part number 82711-26380 as shown above.



## 12. REINSTALL THE CLIP

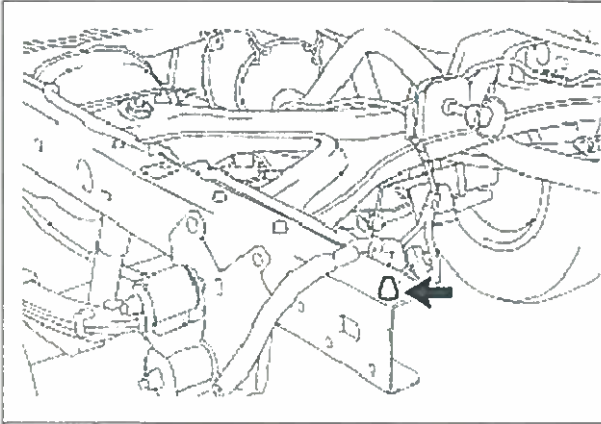

Regular Cab:

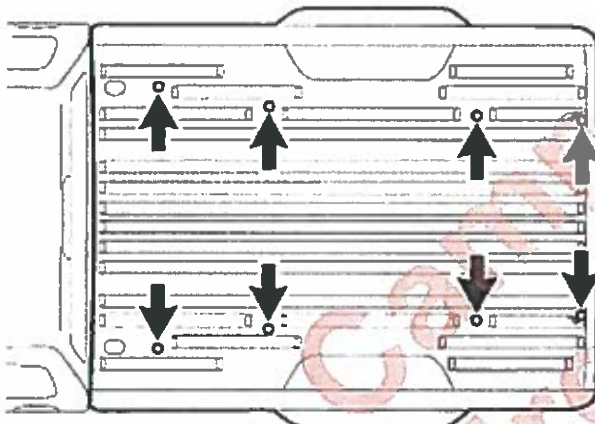

Access Cab:

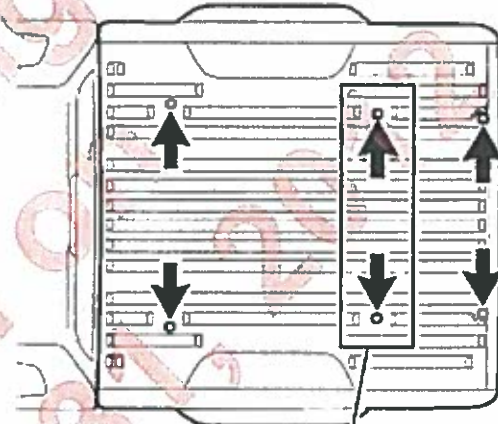

Location A

## 13. REINSTALL THE BED ASSEMBLY

- a) Using a Torx ® T55H Tamper Resistant Socket, reinstall the Torx ® bolts to the bed assembly and tighten to specification.
- Regular Cab: 8 Torx ® bolts
  - Access Cab: 6 Torx ® bolts

**Torque Specification: 86 N·m (877 kgf·cm, 63 ft·lbf)**

### NOTE:

- If a Torx ® bolt is damaged or broken, use part number 64189-0C010. This part number is not listed in the parts catalog. Please note on side step bed vehicles, Torx ® bolt 64189-0C010 cannot be used to replace a damaged or broken bolt in location "A", use the recommended part listed in the catalog.
- Use 4 or more people to reinstall the bed assembly from the frame.
- Evenly support the bed assembly when reinstalling it.

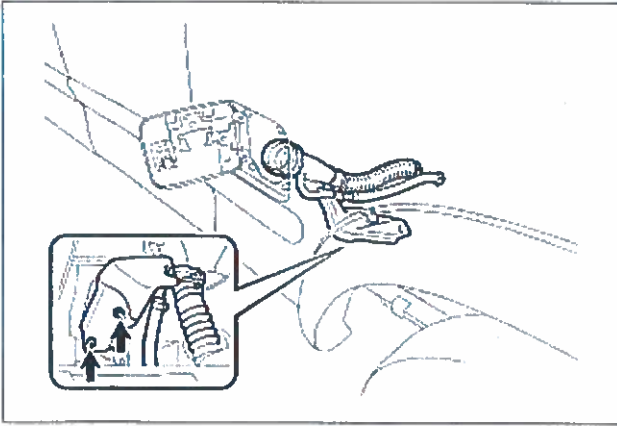

#### 14. RECONNECT THE FUEL INLET PIPE

- a) Reinstall the fuel pipe inlet with the 2 nuts and tighten to specification.

**Torque Specification: 27 N·m (275 kgf·cm, 20 ft·lbf)**

#### 15. REINSTALL THE FUEL TANK FILLER PIPE SHIELD

#### 16. REINSTALL THE REAR MUDGUARDS (IF EQUIPPED)

#### 17. REINSTALL THE SPARE TIRE

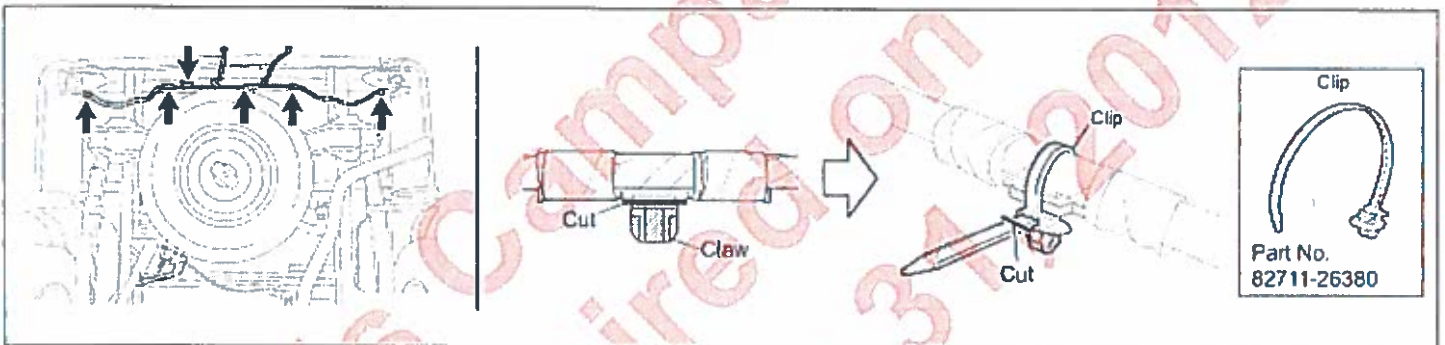

#### 18. RECONNECT THE FRAME WIRE HARNESS

- a) Reconnect the frame wire harness to the bed assembly with the clips.
- b) Reconnect the connectors.

##### NOTE:

- The number of connectors and clips may differ depending on the vehicle specification.
- If the clip(s) indicated for the frame wire harness is damaged or broken, cut off the damaged claw and replace it with part number 82711-26380 as shown above.

#### 18. REINSTALL THE TRAILER HITCH (IF EQUIPPED)

#### 19. REINSTALL THE REAR BUMPER ASSEMBLY

#### 20. REINSTALL THE CENTER REAR BUMPER PAD

#### 21. REINSTALL THE LICENSE PLATE LIGHTS

#### 22. TEST DRIVE THE VEHICLE

- a) Test drive the vehicle and inspect for any issues, abnormalities, drivability concerns, etc.

## VII. APPENDIX

Please make sure all parts (original parts) removed from the vehicle are disposed of in a manner in which they will not be reused, *unless requested for parts recovery return.*

### A. FUEL TANK STRAP WELD NUT REPLACEMENT PROCEDURE

#### • Fuel Tank Strap Weld Nut and Bolt Part Number Information

PART NUMBER	PART DESCRIPTION	QUANTITY
90080 - 11376	BOLT, W/WASHER	AS NEEDED
94151 - 81041	NUT, FLANGE	AS NEEDED

### 1. REMOVE THE REAR BODY (BED) ASSEMBLY, CAB BODY ASSEMBLY, AND OTHER COMPONENTS AS NEEDED

- a) Remove necessary components to gain access to the fuel tank strap bolt and weld nut in need of repair. Component removal is dependent on the weld nut and bolt being repaired.

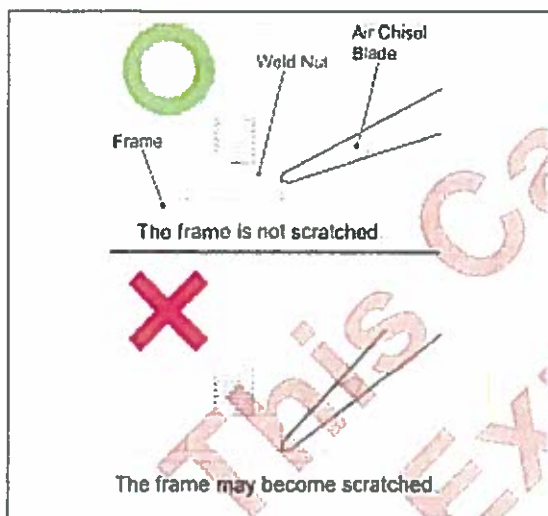

### 2. REMOVE THE WELD NUT

- a) Wear protective eyewear and ear plugs.
- b) Use an air chisel to remove the broken bolt and weld nut.
- c) Take care to ensure the air chisel blade only contacts the weld nut.

#### NOTE:

Do not scratch the frame when removing the weld nut with an air chisel.

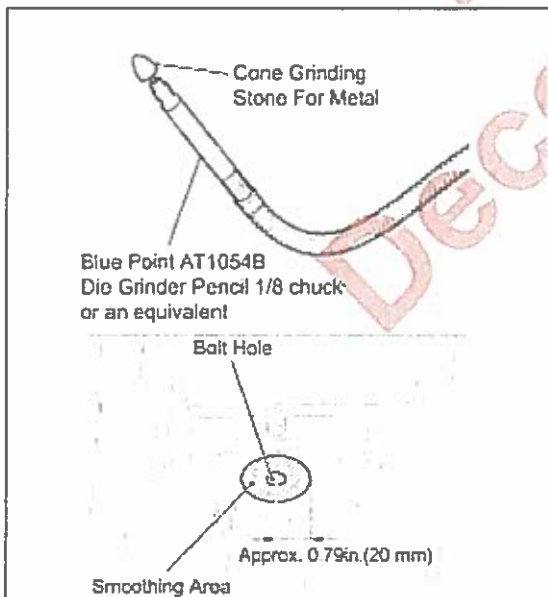

### 3. SMOOTH THE FRAME SURFACE

- a) Smooth the frame surface where the weld nut has been removed with a pencil type grinder and a cone grinding stone.
  - (1) Remove paint and rust from the frame surface surrounding the bolt hole. (Approximately 0.79in. or 20mm radius from the center of the bolt hole.)
  - (2) Carefully grind the surface flat.

#### NOTE:

Do not grind more material than necessary.

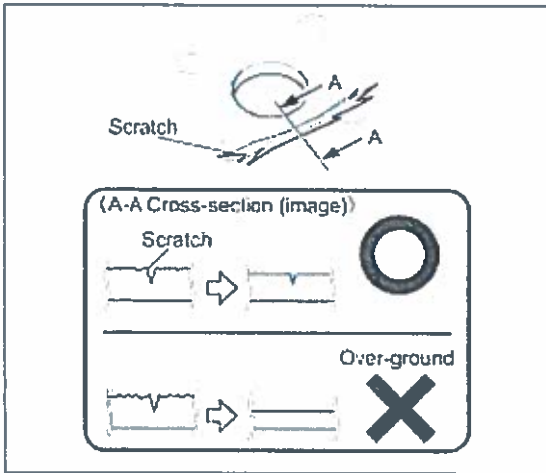

- (3) If the frame was deeply scratched by the air chisel during the weld nut removal, repair the area surrounding the scratch.

**NOTE:**

Attempting to completely remove a deep scratch may lead to excessive removal of material and cause the metal to be thin.

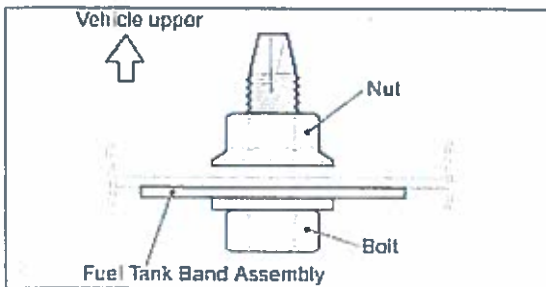

4. **INSTALL THE FUEL TANK BAND ASSEMBLY WITH A NEW BOLT AND NUT**

- a) Degrease and clean the frame surface.
- b) Torque the nut and bolt to spec.

**Torque Spec: 39 N·m (398 kgf·cm, 29 ft·lbf)**

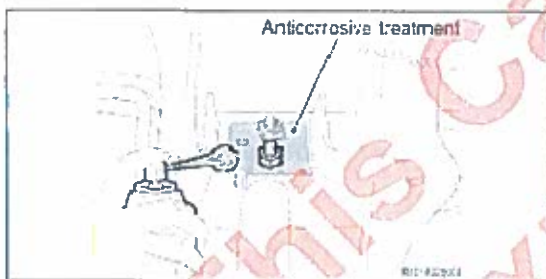

5. **APPLY ANTICORROSIVE TREATMENT TO THE FRAME**

- a) Apply an anti-corrosive paint to the frame surface, bolt, and nut shown in the figure.

**NOTE:**

Do not apply corrosion inhibitor to the frame before tightening the bolt.

**- COMPLETED -**