



Applies To: **2003 3.2CL** – Check the iN VIN status for eligibility
2002–03 3.2TL – Check the iN VIN status for eligibility

February 6, 2015

Safety Recall: Replacement Driver's Airbag Inflator Can Be Over-Pressurized

(Supersedes 10-026, dated September 26, 2014, to revise the information marked by the black bars)

REVISION SUMMARY

The inspection procedure for Takata driver's airbags was removed because all Takata driver's airbag inflators installed in the recall vehicle population are being replaced.

BACKGROUND

The inspection procedure for Takata driver's airbags was removed because all Takata driver's airbag inflators installed in the recall vehicle population are being replaced.

A manufacturing error can produce over-pressurization of some replacement driver's (front) airbag inflators during airbag deployment. If an affected airbag deploys, the increased internal pressure may cause the inflator casing to rupture. Metal fragments could pass through the airbag cushion material, possibly causing an injury or fatality to vehicle occupants.

CLIENT NOTIFICATION

All owners of affected vehicles were sent a notification of this campaign.

Do an **iN VIN status inquiry** to make sure the vehicle is shown as eligible.

Some vehicles affected by this campaign may be in your used vehicle inventory. These vehicles **must** be repaired before they are sold.

Should a dealership sell an unrepaired vehicle that subsequently causes an injury or damage because of the recalled item, the dealership will be solely responsible to the damaged party, and will be required to defend and indemnify American Honda for any resulting claims. To see if a vehicle in inventory is affected by this campaign, do a VIN status inquiry before selling it.

CORRECTIVE ACTION

Install a driver's airbag inflator kit, then return the defective, **undeployed** inflator as directed.

PARTS INFORMATION

NOTE: Always use new Torx bolts to reinstall the airbags. The new Torx bolts are coated with threadlock to make sure they do not come loose.

Torx Airbag Bolts: P/N 90134-S04-A81
 (Two bolts are required to install an airbag)

Driver's Airbag Inflator Kit: P/N 04770-S5A-305*
 Includes inflator with wire harness, locknuts (4), felt tape, felt washers (4), Torx bolts (2), and shipping instructions.

NOTE:

- The inflator kit box must be used to return the old inflator to its supplier, **ideally within 48 hours of the repair**. Be careful not to damage the inflator kit box.
- If the defective, undeployed inflator is not returned, the warranty claim for that vehicle will be charged back to your dealership.

*The kit contains FedEx Ground shipping documents and instructions for the airbag inflator. If you are a dealer in Alaska or Hawaii, call the WPI administrative office at **937-642-2737** for FedEx Air shipping documents and instructions; do not use the documentation included in the airbag inflator kit.

WARRANTY CLAIM INFORMATION

NOTE:

- To avoid non-payment of warranty claims, the serial number on the box of the new airbag inflator must be entered in the Diagnostic Trouble Codes field on each warranty claim. For more information, refer to step 2 of REPAIR PROCEDURE.
- To avoid a warranty claim being charged back to your dealership, the defective, undeployed inflator must be returned to its supplier. Follow the shipping instructions supplied with the inflator kit. If you have any questions about shipping, call Warranty Parts Inspection (WPI) at **937-642-2737**.

OP#	Description	FRT
7525A6	Replace the driver's airbag inflator.	0.5

Failed Part: P/N 06770-S84-A11ZA
Defect Code: 5US00
Symptom Code: R5500
Skill Level: Repair Technician

REPAIR PROCEDURE

NOTE: Be careful not to damage any parts when replacing the inflator, and follow the procedure exactly.

1. Remove the driver's airbag by referring to the applicable electronic service manual.
2. Write down the serial number located on the right side of the new inflator's box. For the warranty claim to be paid, your warranty clerk must enter this serial number in the **Diagnostic Trouble Codes** field on the warranty claim.

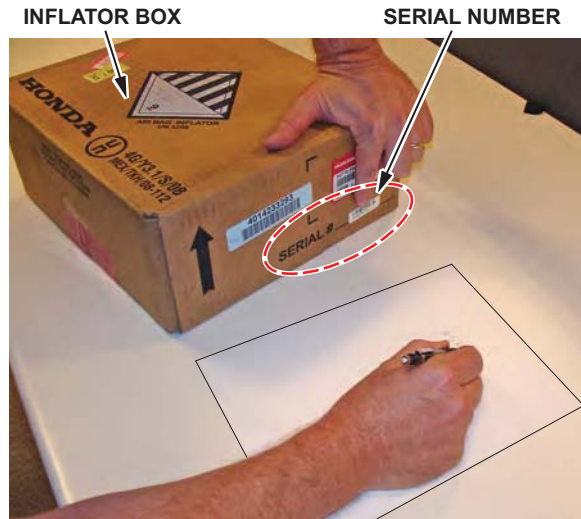

3. Place the airbag, face down, on a clean shop towel.

4. Visually inspect the airbag and the inflator for any unusual writing or markings.
 - If there is nothing unusual about the airbag or the inflator, go to step 5.
 - If there is unusual markings, like an incorrect label or a model year written in marker, the airbag and inflator may not be the correct airbag and/or inflator for the vehicle or it may be a counterfeit part. For more information about counterfeit airbags, you can refer to safercar.gov, enter keywords **MANAGING COUNTERFEIT**, and select *Recommended Dealer Guidance for Managing Counterfeit Air Bags* from the list. **If you suspect that the airbag or inflator is counterfeit, do not continue this procedure.** Contact your DPSM for assistance.

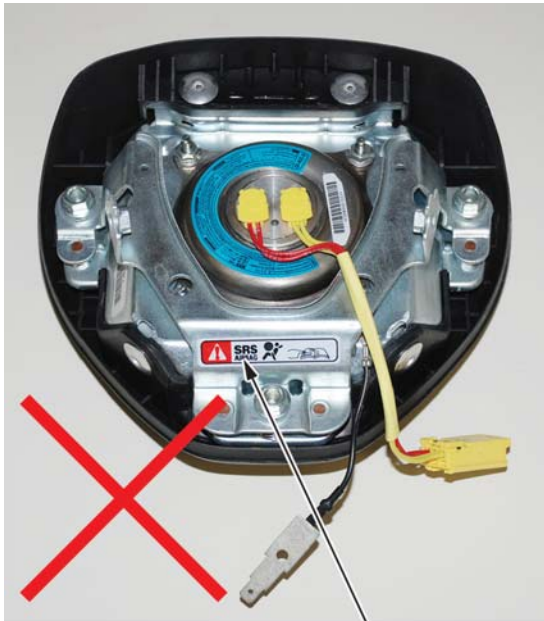

NON-STANDARD SAFETY LABEL

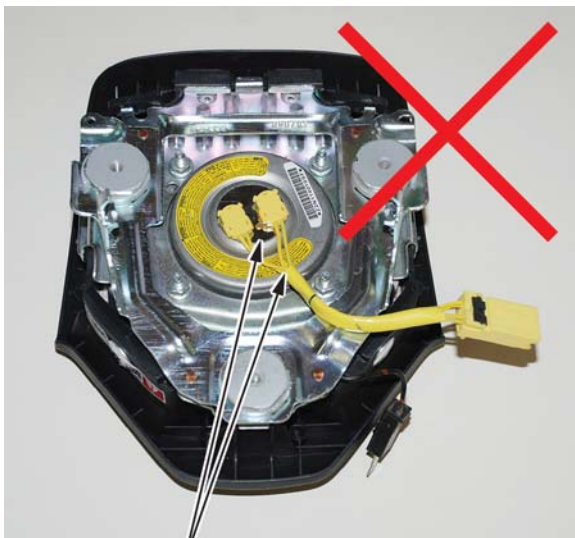

NON-STANDARD WIRES

5. Remove the four horn plate mounting bolts, the mounting bolt felt washers, and the horn plate. The felt washers will not be reused.

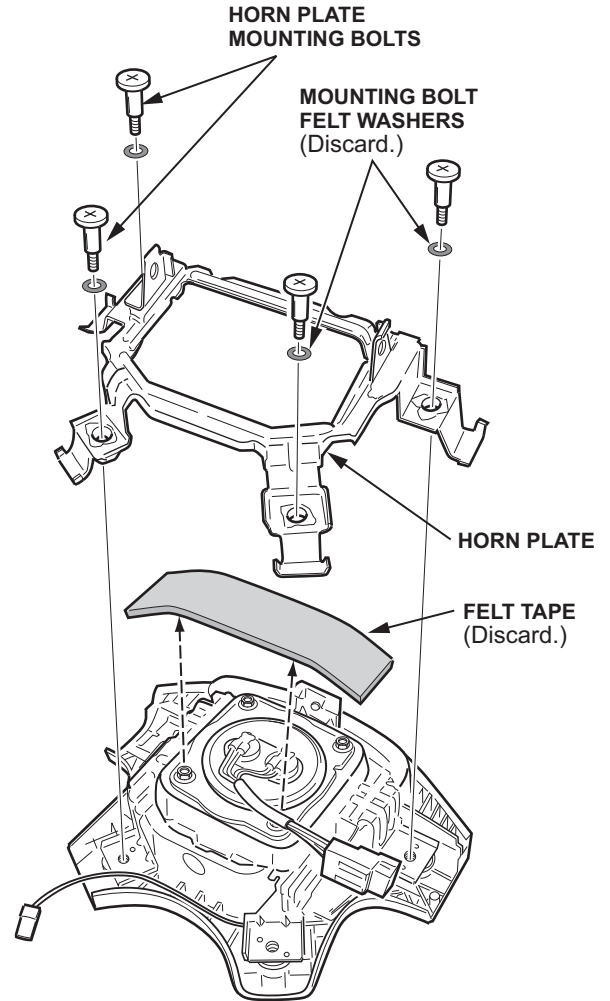

6. Remove and discard the felt tape covering the lower two inflator locknuts.

- Using needle-nose vise grips or a 3/8 in. 6-point socket, remove the four locknuts from the inflator. The locknuts will not be reused.

NOTE: Do not remove the inflator from the airbag until you complete step 8.

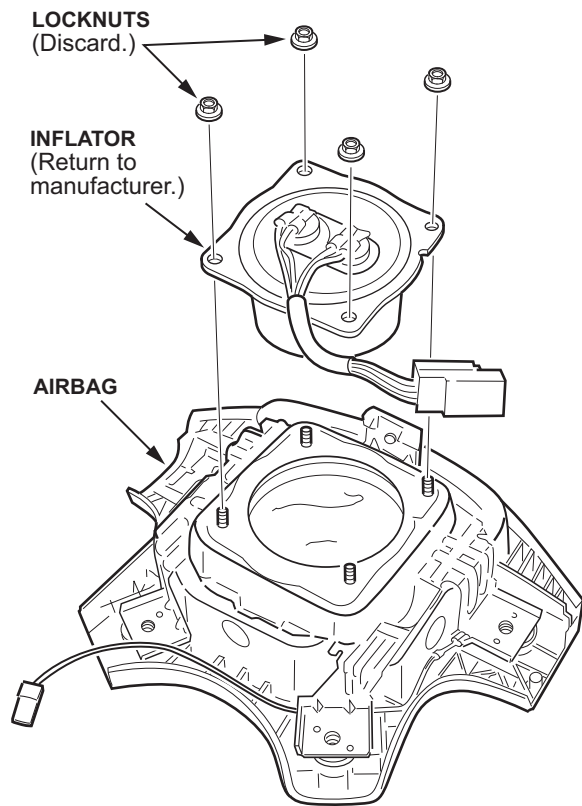

- Use shop air to clean any debris that may be on the inflator, then remove the inflator from the airbag.

NOTE:

- Do not allow any debris to enter the inflator opening in the airbag.
- Do not deploy the inflator.** The inflator must be returned in the box the new inflator came in.

- Turn over the airbag (inflator side down), and shake it to remove any debris from the inflator opening.

- Install the new inflator in the airbag with new locknuts. Torque the locknuts to **3.9 N·m (2.8 lb-ft, 34 lb-in)**.

NOTE:

- The new inflator is slightly different than the original inflator, but they are still interchangeable.
- There may be some minor surface rust or corrosion on the new inflator; this is OK.

- Cover the lower two inflator locknuts with new felt tape.

- Reinstall the horn plate with new felt washers on its mounting bolts. Torque the mounting bolts to **3.4 N·m (2.5 lb-ft, 30 lb-in)**, then make sure the horn plate moves freely.

- Reinstall the driver's airbag using new Torx bolts:
 - Refer to the appropriate service manual, or
 - Online, enter keywords **DRIVER AIR**, and select **Driver's Airbag Replacement** from the list.

- Center-punch a completion mark below the fifth character of the engine compartment VIN:

19XXXXXXXXXXXXXXXX

Center-punch here.

- Give your warranty clerk the inflator serial number you wrote down in step 2. For the warranty claim to be paid, your warranty clerk must enter the appropriate serial number in the **Diagnostic Trouble Codes** field on each warranty claim.