



I N F I N I T I

EMPOWER THE DRIVE

CAMPAIGN BULLETIN

Body Seal Retailer Inventory

Reference: PG7B3

Date: March 23, 2017

Attention: Retailer Principal, Sales, Parts and Service Managers

UPDATE March 23, 2017

The announcement has been revised to inform retailers to resume repairs using the revised procedure included with this announcement.

- Please refer to the revised announcement and adhere to the new warning information and procedures for removing the cowl cover and applying sealant
- **Please discard earlier versions of this bulletin.**

Affected Models/Years:	Affected Population:	Retailer Inventory:	SERVICE COMM Activation date:	Stop Sale In Effect
MY2017 QX30 (H15)	NA	1,936	March 3, 2017	NO

**** Retailer Announcement ****

Infiniti is conducting a retailer inventory quality action to apply body sealer on **1,936** specific 2017 QX30 vehicles identified in Service Comm. Certain vehicles may have a gap between the air box lid and the bulkhead as a result of incorrectly applied paint and body sealer and/or incorrect fastening of the air box lid. Retailers will apply additional sealer and ensure the air box lid is correctly fastened to prevent water intrusion into the passenger compartment.

Affected vehicles are **not** subject to stop sale and are either currently in retailer inventory or assigned and in transit to the retailer. Infiniti requests retailers complete this inspection prior to sale to ensure client satisfaction.

**** What Retailers Should Do ****

PLEASE FOLLOW THE ATTACHED REVISED REPAIR INSTRUCTIONS:

1. Verify if vehicles are affected by this client satisfaction initiative using Service Comm I.D. PG7B3
 - New vehicles in retailer inventory can also be identified using DCS (Sales-> Vehicle Inventory, and filter by Open Campaign).
 - Refer to IPSB 15-286 for additional information
 - Please continue to check newly arriving inventory for campaign applicability.
2. Use the attached procedure to apply body sealer and ensure correct fastening of the Heating, Ventilation, and Air Conditioning (HVAC) air box lid.

3. The service department should submit the applicable warranty claim for the action performed so it can be closed on Service Comm and release the vehicle.

******* Retailer Responsibility *******

It is the retailer's responsibility to check Service Comm using the appropriate campaign I.D for the inspection status on each affected vehicle currently in new vehicle inventory. Infiniti requests retailers to perform this repair on new vehicles in inventory prior to being retailed to ensure client satisfaction.

Thank you for your prompt attention to this matter.



PG7B3 - 2017 Q30/QX30 (H15) BODY SEAL REPAIR

SERVICE PROCEDURE:

1. Verify the VIN of the affected.
2. Clean windshield glass and wiper blades to avoid windshield damage.
3. Switch ignition on and cycle wipers so they set to the auto stop position.
4. Open the hood and remove the three plastic caps covering the 16MM nuts holding on the windshield wiper arms. (Figure 1).



Figure 1

5. Locate the three 16MM nuts that are under the caps and remove them.
6. Using a grease pencil, mark the wiper arm in relation to the mounting point on the wiper arm stud. (Figure 2).



Figure 2

CAUTION:

USE GREAT CARE TO NOT STRIKE OR BREAK THE WINDSHIELD WHEN REMOVING THE WINDSHIELD WIPER ARMS.

- Using one hand lift the wiper blade slightly off the windshield and with the other hand gently rock the arm at the mounting point to loosen the arm on the stud, and remove the wiper arms. (Figure 3).

IMPORTANT: Use great caution and do not damage the windshield when removing the wiper arm assemblies.



Figure 3

- Remove the cowl top seal and set aside. (Figure 4).



Figure 4

- Remove the (4) 8MM bolts that hold the cowl top cover in place. (Figure 5).

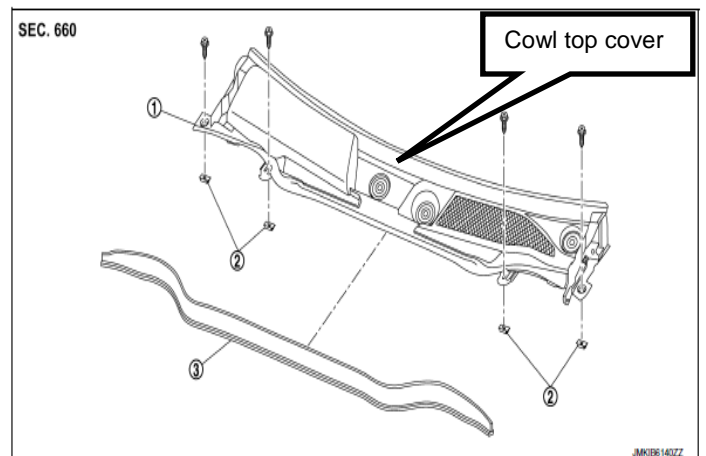

Figure 5

CAUTION:

USE GREAT CARE TO NOT USE FORCE WHEN REMOVING THE COWL TOP COVER. NOT REMOVING THE COWL TOP COVER AS INSTRUCTED COULD BREAK THE WINDSHIELD!

10. Remove the front washer tube-fixing pawls from the cowl top cover. (Figure 6).



Figure 6

11. Pull cowl top cover up just enough to clear the wiper arm studs and pull gently forward starting from the driver's side. (Figure 7).

Caution: Use great caution when removing the cowl top cover to avoid breaking the windshield.

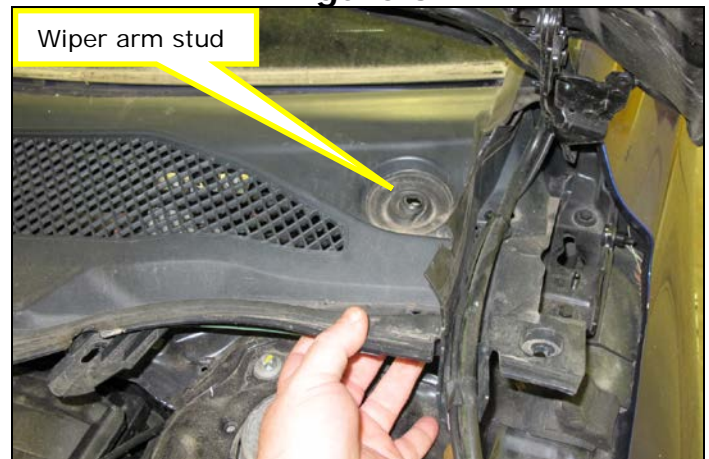

Figure 7

12. Remove the air box inlet assembly by pulling up on the release tabs. (Figure 8).



Figure 8

13. Figure 9 displays the passenger side showing areas of potential leaks.

- In this area is where you will apply sealer.

NOTE:

- The dashed arrow on the far right of the picture is under the corner of the windshield, this is the area of greatest concern.
- Apply sealer to all areas where the arrows are pointing, on both sides of the vehicle.
- **IMPORTANT:** Use 3M 540 Polyurethane Sealant for this repair and allow 60 minutes for the sealer to harden before reassembling the car.

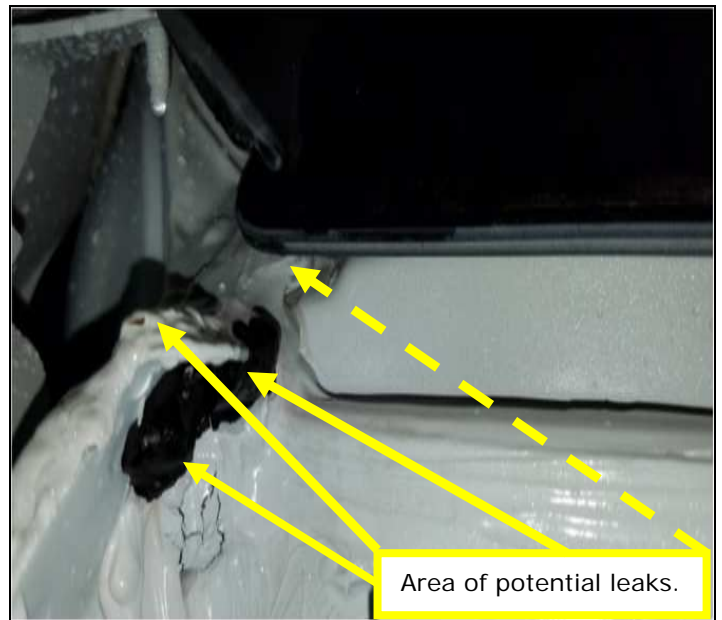

Figure 9



3M 540 SEALER

14. Figure 10 is a close up of a potential leak area under passenger side windshield.

- Apply sealer to this area on both sides of the car, driver and passenger.



Figure 10

16. When applying sealer to the vehicle use your finger or a plastic wedge to push sealant into the areas of concern.

- **IMPORTANT:** When applying the sealant care must be taken not to fill the area between the body and the glass area where the plastic plate fits, this is to avoid excess load being placed on the glass when the cowl is refitted.
- **IMPORTANT:** Use 3M 540 Polyurethane Sealant for this repair and allow 60 minutes for the sealer to harden before reassembling the car.



Figure 11

17. Figure 12 shows sealer applied to areas of concern, passenger side.

- **IMPORTANT:** only place sealant in the areas designated in Figures 12 & 13.
- **NOTE:** In this picture, the lower corner windshield trim is removed for the picture.

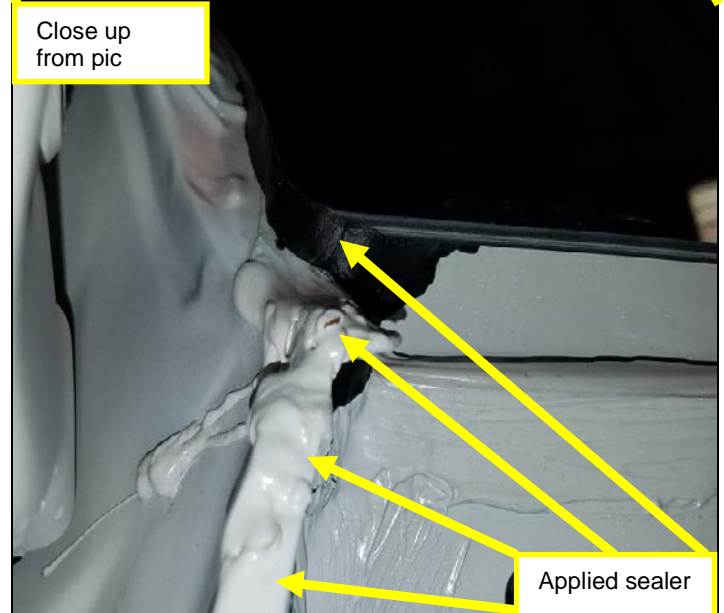

Figure 12

18. Figure 13 shows sealer applied to driver's side of the vehicle.

- **IMPORTANT:** Use 3M 540 Polyurethane Sealant for this repair and allow 60 minutes for the sealer to harden before reassembling the car.
- **NOTE:** In this picture, the black lower corner windshield trim is removed for the picture.

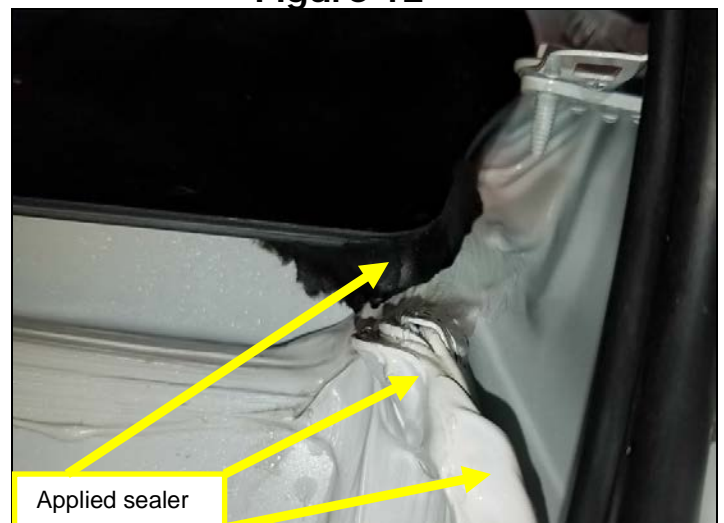
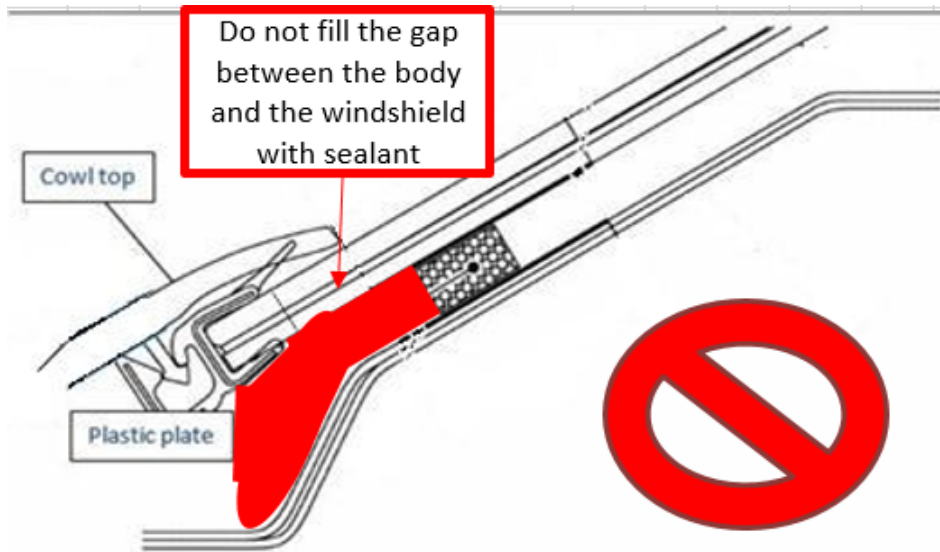

Figure 13

IMPORTANT:

BELOW ARE EXAMPLES OF WHERE NOT TO APPLY SEALANT. SEALANT APPLIED IN AREAS CIRCLED IN RED WILL CAUSE DAMAGE TO THE WINDSHIELD



- **IMPORTANT:** Do not apply any sealant along the bottom edge of the windshield on either side of the vehicle. Doing so will cause windshield breakage when reinstalling the cowl top cover!



19. At this point, you will reinstall the air box inlet cover.

- **Note:** The bottom side of the air box inlet cover hooks where the yellow arrows are pointing. (Figure 14).

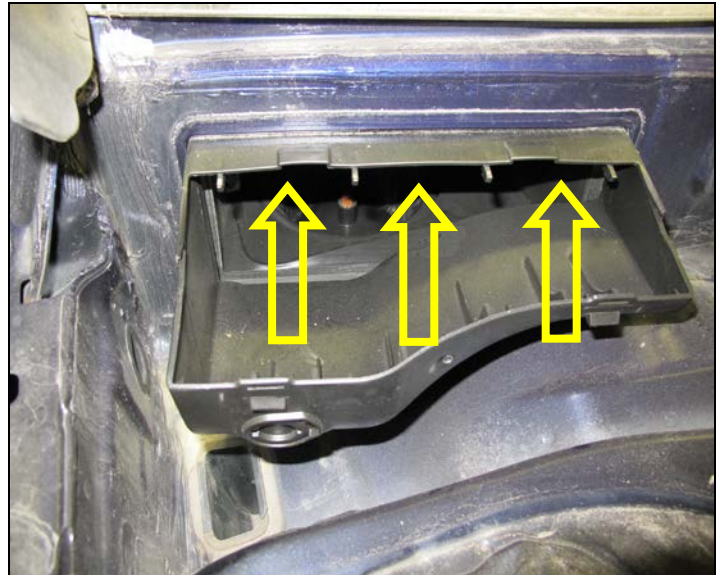

Figure 14

20. Looking at the bottom side of the air box inlet cover, make sure the three clips with the yellow arrows hook onto the back of the air box. (Figure 15).



Figure 15

21. Verify the air box inlet cover is attached in the front and rear by pulling up on it gently.



Figure 16

CAUTION:

USE GREAT CARE TO NOT USE FORCE WHEN INSTALLING THE COWL TOP COVER. USING FORCE COULD BREAK THE WINDSHIELD

IMPORTANT: The lower portion of windshield and groove in cowl top cover must be clean and free of debris prior to installation

- 22. Clean lower portion of windshield and bottom edge. Wipe inside of groove in in cowl top cover with damp rag making sure any grit or debris is removed in order to prevent any scratches along lower edge of glass.

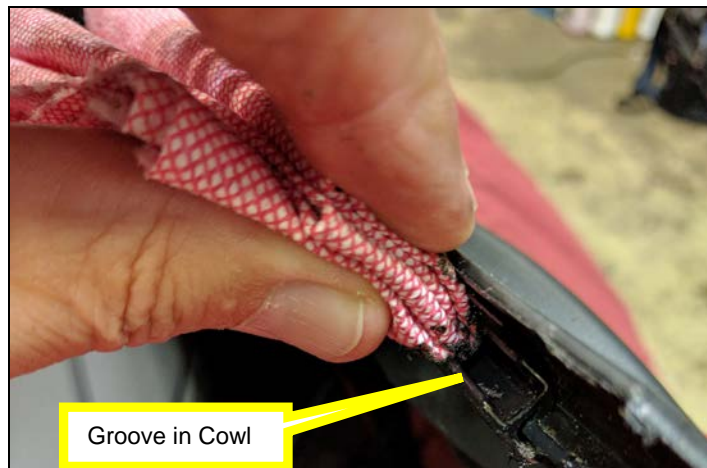

Figure 17

- 23. Installing the cowl top cover needs to be done smoothly and without application of excessive force. Special care should be taken on the Airbox side where the Airbox rubber lip sits against the cowl top. It is necessary to flex the rubber lip to allow fitment of the cowl top.

IMPORTANT: Use caution and do not force the cowl top cover into place. Forcing could break the windshield when reinstalling the cowl top cover.

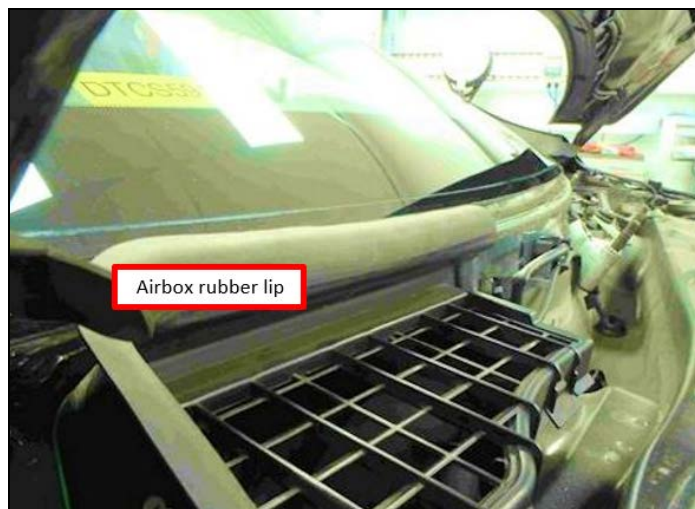

Figure 18

- 24. Reinstall the (4) 8MM bolts for the cowl top cover. (Figure 19).

- 25. Reinstall the cowl top cover seal on to the cowl top cover.

IMPORTANT: Use great caution and do not damage the windshield when installing the wiper arm assemblies.

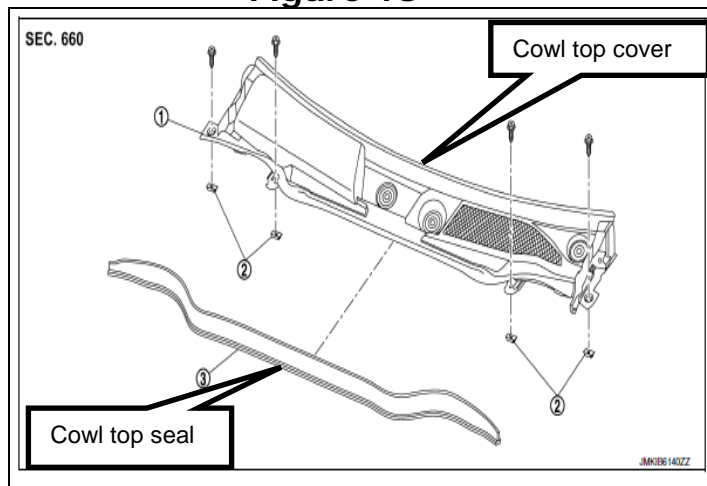

Figure 19

26. Reinstall the wiper arm assemblies, aligning the marks left from the grease pencil from step 2.



Figure 20

27. Reinstall the three 16MM nuts that hold on the wiper arms and torque to **15 (ft-LB) OR 30Nm**.



Figure 21

28. Reinstall the (3) plastic caps that cover the wiper arm 16MM nuts.



Figure 22

29. Reinstall the two-windshield washer tube fixing pawls to the cowl top cover, on the driver's side. (Figure 23).

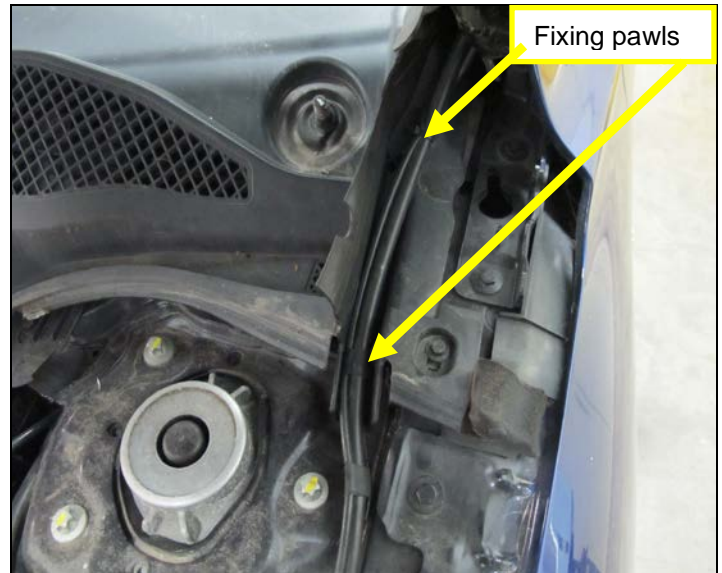

Figure 23

30. Close the hood and cycle the windshield wipers to make sure that they park properly at the bottom of the windshield.

- **NOTE:** The hood must be closed for the windshield wiper to work.



Figure 24

Prepare for application of 3M 540 Polyurethane sealant (or equivalent* automotive sealant).

- Load the cartridge into a 1:1 dispensing gun.
- Puncture the end of the cartridge before installing the applicator tip.
- Screw on the applicator tip onto the cartridge.

***Equivalent automotive sealer MUST be a product that has been manufactured specifically for sealing vehicle body panel seams.**



3M 540 sealant

PARTS INFORMATION

Description	Qty	Part #
3M 540 Polyurethane Sealant	As needed	Locally sourced

***Equivalent automotive sealer MUST be a product that has been manufactured specifically for sealing vehicle body panel seams.**

NOTE:

- One 300ML /10.1 FL OZ cartridge can be used for more than one vehicle.
- This product is available in five colors, any color can be used.

CLAIMS INFORMATION:

Submit claim using the following claims coding:

Work Order Line Type: "CM" Campaign

Campaign: PG7B3

Claim Type:	CM			
PNC:	PG7B3			
Symptom:	ZZ			
Diagnosis:	99			
Description:	Op Code	Flat Rate Time	Parts Required on claim	Expense Code Required
Body seal repair	PG7B30	0.7 Hrs.	No	YES

EXPENSE CODE	DESCRIPTION	MAX AMOUNT
009/Sealant	3M 540 Polyurethane Sealant	\$16.00 MAX

- **Each expense code can be claimed only once per repair order.**
- **Corresponding op-code must be cleared with each expense code.**