

# 2015 PRE-DELIVERY SERVICE CHECK SHEET

BEFORE INSPECTION	OK	Adjust/ Repair
01 Install DCC fuse (see page 2) .....	<input type="checkbox"/>	<input type="checkbox"/>
02 Install radio antenna* .....	<input type="checkbox"/>	<input type="checkbox"/>
FUNCTIONAL OPERATION		
<i>Apply parking brake and cycle ignition "IG-ON," place gear selector in reverse; turn on lights and rear defogger. Unlock all doors, release fuel door, release trunk hatch.</i>		
01 Check dome, courtesy, map, and sun visor lights* .....	<input type="checkbox"/>	<input type="checkbox"/>
02 Check warning/indicator lights, gauges, and horn .....	<input type="checkbox"/>	<input type="checkbox"/>
03 Check windshield wipers and washers .....	<input type="checkbox"/>	<input type="checkbox"/>
04 Check headlights, instrument lights, turn signals, dimmer switch, emergency flashers, and brake lights .....	<input type="checkbox"/>	<input type="checkbox"/>
05 Check inside/outside rear view mirror operation/adjustment .....	<input type="checkbox"/>	<input type="checkbox"/>
06 Check power outlet* and cigarette lighter .....	<input type="checkbox"/>	<input type="checkbox"/>
07 Check audio/navigation* systems, set SSP* to iQ and set clock .....	<input type="checkbox"/>	<input type="checkbox"/>
08 Install shift-lock override button cover .....	<input type="checkbox"/>	<input type="checkbox"/>
WALKAROUND INSPECTION		
<i>Start at left front door. Check window and door lock operation (from master power switch, if equipped). Continue around vehicle in a counterclockwise direction checking each door and window operation, child door locks, seat belts, interior condition, all lights, luggage compartment contents. Finish by checking headlight aim and continue into UNDER HOOD checks.</i>		
01 Check door and door lock operation, including each wireless remote control/theft deterrent system* .....	<input type="checkbox"/>	<input type="checkbox"/>
02 Check power window operation .....	<input type="checkbox"/>	<input type="checkbox"/>
03 Check that engine starts with all keys .....	<input type="checkbox"/>	<input type="checkbox"/>
04 Check seats and seat belt operation .....	<input type="checkbox"/>	<input type="checkbox"/>
05 Check rear defogger .....	<input type="checkbox"/>	<input type="checkbox"/>
06 Check side marker, tail, backup, and license plate lights .....	<input type="checkbox"/>	<input type="checkbox"/>
07 Check rear hatch/cargo area trim appearance .....	<input type="checkbox"/>	<input type="checkbox"/>
08 Check tire repair kit and tool installation .....	<input type="checkbox"/>	<input type="checkbox"/>
09 Check headlight aim .....	<input type="checkbox"/>	<input type="checkbox"/>
UNDER HOOD		
01 Check engine oil and ATM fluid levels .....	<input type="checkbox"/>	<input type="checkbox"/>
02 Check brake fluid level .....	<input type="checkbox"/>	<input type="checkbox"/>
03 Check engine coolant level .....	<input type="checkbox"/>	<input type="checkbox"/>
04 Check windshield washer fluid level .....	<input type="checkbox"/>	<input type="checkbox"/>
<b>05 Check battery state-of-charge using Digital Battery System Analyzer (SOC Reading: _____%) .....</b>	<input type="checkbox"/>	<input type="checkbox"/>
06 Inspect for fuel, oil, coolant, and other fluid leaks .....	<input type="checkbox"/>	<input type="checkbox"/>
Comments: _____ _____ _____ _____		

UNDER VEHICLE (ON HOIST)	OK	Adjust/ Repair
<b>01 Remove disc brake anti-rust covers/anti-corrosion wheel film* .....</b>	<input type="checkbox"/>	<input type="checkbox"/>
02 Activate and initialize Tire Pressure Warning System (TPWS) (see page 2) .....	<input type="checkbox"/>	<input type="checkbox"/>
03 Inspect tires for defects/damage .....	<input type="checkbox"/>	<input type="checkbox"/>
04 Install wheel covers/caps/spare tire wheel covers* .....	<input type="checkbox"/>	<input type="checkbox"/>
05 Install rubber body plugs (stored in glove box) .....	<input type="checkbox"/>	<input type="checkbox"/>
06 Inspect for fuel, oil, coolant, and other fluid leaks .....	<input type="checkbox"/>	<input type="checkbox"/>
07 Visually check bolts and nuts on chassis and powertrain for looseness .....	<input type="checkbox"/>	<input type="checkbox"/>
08 Inspect under the vehicle for damage, rust, etc. ....	<input type="checkbox"/>	<input type="checkbox"/>
<b>09 Install front wheel opening extension pads .....</b>	<input type="checkbox"/>	<input type="checkbox"/>
ROAD TEST		
<i>A complete road test helps assure customer satisfaction. Drive vehicle over a variety of road surfaces and driving conditions. Check for unusual noise and driving performance.</i>		
<b>Enter Odometer Reading</b>		
Reading Before Test: _____ Reading After Test: _____		
01 Check cold engine operation .....	<input type="checkbox"/>	<input type="checkbox"/>
02 Check engine operation during warm-up .....	<input type="checkbox"/>	<input type="checkbox"/>
03 Check engine at normal operating temperature .....	<input type="checkbox"/>	<input type="checkbox"/>
04 Check automatic transmission operation .....	<input type="checkbox"/>	<input type="checkbox"/>
05 Check brake and parking brake operation .....	<input type="checkbox"/>	<input type="checkbox"/>
06 Check steering operation and off-center/vehicle pull/flutter .....	<input type="checkbox"/>	<input type="checkbox"/>
07 Inspect for abnormal noise and vibration .....	<input type="checkbox"/>	<input type="checkbox"/>
08 Inspect for squeaks and rattles .....	<input type="checkbox"/>	<input type="checkbox"/>
09 Check heater and A/C operation .....	<input type="checkbox"/>	<input type="checkbox"/>
10 Check speedometer operation .....	<input type="checkbox"/>	<input type="checkbox"/>
11 Check cruise control operation .....	<input type="checkbox"/>	<input type="checkbox"/>
FINAL INSPECTION AND CLEANING		
01 Remove interior protective covers, unnecessary labels, tags, etc. (Remove protective covers just before delivery to customer) .....	<input type="checkbox"/>	<input type="checkbox"/>
<b>02 Verify floor mat application and install using retaining clips* .....</b>	<input type="checkbox"/>	<input type="checkbox"/>
03 Visually inspect all interior parts for installation, damage, fit, dirt, etc. ....	<input type="checkbox"/>	<input type="checkbox"/>
04 Remove Rapgard™ film & clear protective bumper film* .....	<input type="checkbox"/>	<input type="checkbox"/>
05 Wash and clean vehicle .....	<input type="checkbox"/>	<input type="checkbox"/>
06 Inspect paint finish for scratches, chips, rust, dents, damage, etc. ....	<input type="checkbox"/>	<input type="checkbox"/>
07 Inspect exterior body parts for proper installation, damage, rust, etc. ....	<input type="checkbox"/>	<input type="checkbox"/>
08 Place Owner's Guide and first aid kit portfolio* in glove box .....	<input type="checkbox"/>	<input type="checkbox"/>
09 Place oil change sticker on inside of windshield, top left corner .....	<input type="checkbox"/>	<input type="checkbox"/>
10 Perform Techstream Health Check .....	<input type="checkbox"/>	<input type="checkbox"/>
11 Install front license plate or cover* (see page 2) .....	<input type="checkbox"/>	<input type="checkbox"/>
<b>* Inspect or install when equipped/required.</b>		

Completion and retention of this form is required to comply with Toyota's Warranty Policy.

 \_\_\_\_\_  
TECHNICIAN'S SIGNATURE

 \_\_\_\_\_  
SERVICE MANAGER'S SIGNATURE

 \_\_\_\_\_  
NAME (PLEASE PRINT)

 \_\_\_\_\_  
NAME (PLEASE PRINT)

**We hereby certify that all items on this form have been checked and corrected for proper operation as required.**

Date

Dealer Name

Dealer Code

Vehicle Identification Number (Sticker)

## DCC FUSE INSTALLATION

To minimize battery discharge the DCC fuse has been removed and is stored in the engine compartment relay block. Install the DCC fuse (30A) and confirm all related DTCs are cleared.

### DTC Clearing Procedure

1. Connect Techstream.
2. Cycle the ignition switch to the "IG-ON" position.
3. Using Techstream, check any other codes being output.
4. Erase DTCs (B1650 and B1794) and Freeze Frame Data.

#### NOTE

If any DTCs besides B1650 and B1794 appear, repair the applicable system according to the Repair Manual.

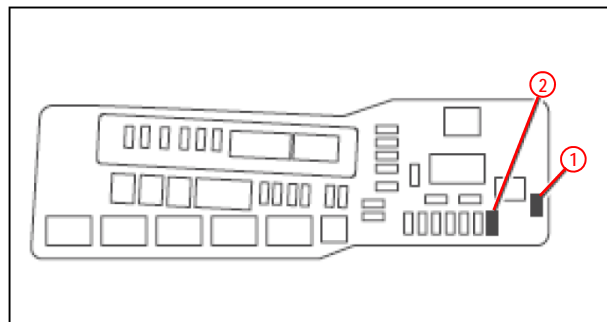

- 1 Remove DCC Fuse (30A)
- 2 Install DCC Fuse (30A) Here

## TIRE PRESSURE WARNING SYSTEM (TPWS) ACTIVATION AND INITIALIZATION

### Activation Procedure

1. Connect Techstream.
2. Cycle the ignition switch to the "IG-ON" position and check that the Low Tire Pressure Warning Light blinks for 1 minute and then remains illuminated.
3. Press or remove the valve core to reduce the tire inflation pressure rapidly by 6 psi (0.4 kfg/cm<sup>2</sup>, 40 kPa), or more, within 30 seconds.
4. Check that the Low Tire Pressure Warning Light goes OFF after all the TPWS sensors are activated.

#### NOTE

To adjust the tire pressure correctly when the outside temperature is significantly colder than shop temperature, perform a Health Check using Techstream and select the "Compensation Tire Pressure" checkbox. Compensation pressures will be displayed on the Health Check results screen. Adjust the tire pressure when the tires are cold.

5. Using Techstream, check for DTCs (C2111-C2114). If no DTCs are stored, continue to Initialization procedure. If these DTCs are stored, repeat step 3.

### Initialization Procedure

Refer to the Repair Manual for the [Initialization procedure](#).

## FRONT LICENSE PLATE OR COVER INSTALLATION\*

For states that require a front license plate, follow the front license plate installation procedure below. For states that do not require a front license plate, follow the front license plate cover (stored in the luggage compartment) installation procedure.

### Front License Plate Installation Procedure

1. Align the installation holes on the front license plate with the dimples on the front bumper.
2. Directly screw 2 self-tapping screws into the dimples to install the front license plate.

Use self-tapping screws of a non-corroding type with the following dimensions.

**Nominal Length: 15.0 — 20.0 mm (0.60 — 0.79 in.)**

**Diameter: 6.0 mm (0.24 in.)**

### Front License Plate Cover Installation Procedure

1. Remove the 2 metal spring nuts from the bumper cover and discard.
2. Clean the area where the license plate cover adhesive will contact the bumper.
3. Attach the 2 plastic clips to the license plate cover.
4. Remove the 2 strips of adhesive cover from the license plate cover.
5. Insert the plastic clips into the bumper cover holes.
6. Ensure the adhesive strips contact the bumper by pressing on the edges of the license plate cover.

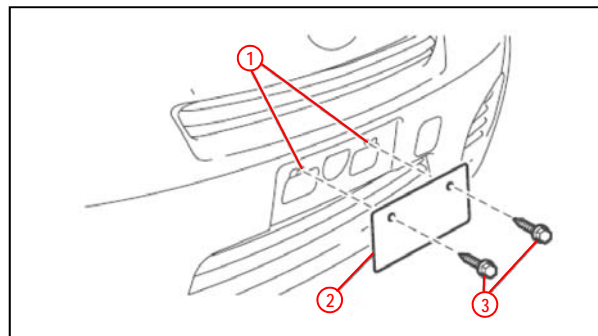

- 1 Dimples
- 2 License Plate
- 3 Self-tapping Screws

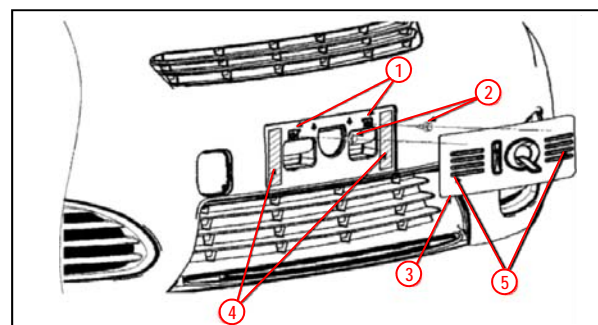

- 1 Spring Nuts/Bumper Holes
- 2 Plastic Clips
- 3 License Plate Cover
- 4 Adhesive Tape Contact Location
- 5 Adhesive Tape (Backside of Cover)