

JTB00423NAS2

TECHNICAL BULLETIN

12 DEC 2016



© Jaguar Land Rover North America, LLC

NOTE: The information in Technical Bulletins is intended for use by trained, professional Technicians with the knowledge, tools, and equipment required to do the job properly and safely. It informs these Technicians of conditions that may occur on some vehicles, or provides information that could assist in proper vehicle service. The procedures should not be performed by 'do-it-yourselfers'. If you are not a Retailer, do not assume that a condition described affects your vehicle. Contact an authorized Jaguar service facility to determine whether this bulletin applies to a specific vehicle.

INFORMATION

This reissue replaces all previous versions. Please destroy all previous versions.

Changes are highlighted in blue

SECTION:

303-00

SUBJECT/CONCERN:

Accessory Drive Belt Idler Pulley 'Humming' Noise

AFFECTED VEHICLE RANGE:

MODEL:	MODEL YEAR:	VIN:	ASSEMBLY PLANT:	APPLICABILITY:
F-PACE (X761)	2017 Onwards	045000 Onwards	Solihull	V6 S/C 3.0L Petrol
F-TYPE (X152)	2014 Onwards	K00001 Onwards	Castle Bromwich	V6 S/C 3.0L Petrol /V8 S/C 5.0L Petrol
XE (X760)	2017 Onwards	P00126 Onwards	Castle Bromwich	V6 S/C 3.0L Petrol
XE (X760)	2017 Onwards	921222 Onwards	Solihull	V6 S/C 3.0L Petrol
XF (X260)	2016 Onwards	Y00461 Onwards	Castle Bromwich	V6 S/C 3.0L Petrol
XF (X250)	2010-2015	R47154-U88785	Castle Bromwich	V6 S/C 3.0L Petrol /V8 5.0L Petrol/V8 S/C 5.0L Petrol
XJ Range (X351)	2010 Onwards	V00001 Onwards	Castle Bromwich	V6 3.0L Petrol/V6 S/C 3.0L Petrol /V8 5.0L Petrol/V8 S/C 5.0L Petrol
XK Range (X150)	2010-2015	B32753-B52041	Castle Bromwich	V8 5.0L Petrol/V8 S/C 5.0L Petrol

MARKETS:

NAS

CONDITION SUMMARY:

SITUATION:

A 'humming' noise may be evident from the engine when the engine is idling.

CAUSE:

This may be caused by dust and/or water ingress to the accessory drive belt idler pulley bearing.

ACTION:

Should a customer express this concern, follow the Service Instruction below.

PARTS:

NOTE:

Following removal, retain the idler pulley assembly. Raise an Electronic Product Quality Report (EPQR) supplemented with photographs/video files where possible. Include an address and contact details so that a Priority Parts Return (PPR) can be set up for return of the displaced idler pulley assembly.

PART NUMBER	DESCRIPTION	QUANTITY:
C2D51367	Idler bracket assembly	1

TOOLS:

Refer to Workshop Manual for any required special tools.

WARRANTY:

NOTE:

Following removal, retain the idler pulley assembly. Raise an Electronic Product Quality Report (EPQR) supplemented with photographs/video files where possible. Include an address and contact details so that a Priority Parts Return (PPR) can be set up for return of the displaced idler pulley assembly.

NOTES:

- Repair procedures are under constant review, and therefore times are subject to change; those quoted here must be taken as guidance only. Always refer to TOPIx to obtain the latest repair time.
- DDW requires the use of causal part numbers. Labor only claims must show the causal part number with a quantity of zero.

DESCRIPTION	SRO	TIME (HOURS)	CONDITION CODE	CAUSAL PART
Idler pulley and bracket assembly - Accessory drive - RH - Renew - F-PACE (X761)	12.10.53	0.2	42	C2D21151
Idler pulley and bracket assembly - Accessory drive - RH - Renew - F-TYPE (X152)	12.10.53	0.2	42	C2D21151
Idler pulley and bracket assembly - Accessory drive - RH - Renew - XE (X760)	12.10.53	0.2	42	C2D21151
	12.10.53	0.2	42	C2D21151

DESCRIPTION	SRO	TIME (HOURS)	CONDITION CODE	CAUSAL PART
Idler pulley and bracket assembly - Accessory drive - RH - Renew - XF (X260)				
Idler pulley and bracket assembly - Accessory drive - RH - Renew - XF (X250)	12.10.53	0.3	42	C2D21151
Idler pulley and bracket assembly - Accessory drive - RH - Renew - XJ (X351)	12.10.53	0.3	42	C2D21151
Idler pulley and bracket assembly - Accessory drive - RH - Renew - XK (X150)	12.10.53	0.3	42	C2D21151

NOTE:

Normal Warranty procedures apply.

SERVICE INSTRUCTION:**NOTE:**

The idler pulley bracket assembly must be replaced as a complete assembly and must not be dismantled to a lower level.

- 1 Remove the T-connector from the air cleaner outlet pipe (see TOPIx Workshop Manual section 303-12: Intake Air Distribution and Filtering - Air Cleaner Outlet Pipe T-Connector).

2

NOTE:

Note the fitted position of the accessory drive belt.

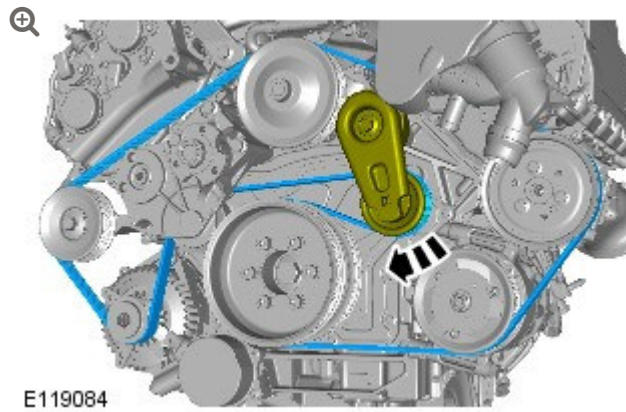

Remove the accessory drive belt from the idler pulley.

3

NOTES:

- The fasteners must be retained for re-use.
- Following removal, retain the idler pulley assembly. Raise an Electronic Product Quality Report (EPQR) supplemented with photographs/video files where possible. Include an address and contact details so that a Priority Parts Return (PPR) can be set up for return of the displaced idler pulley assembly.

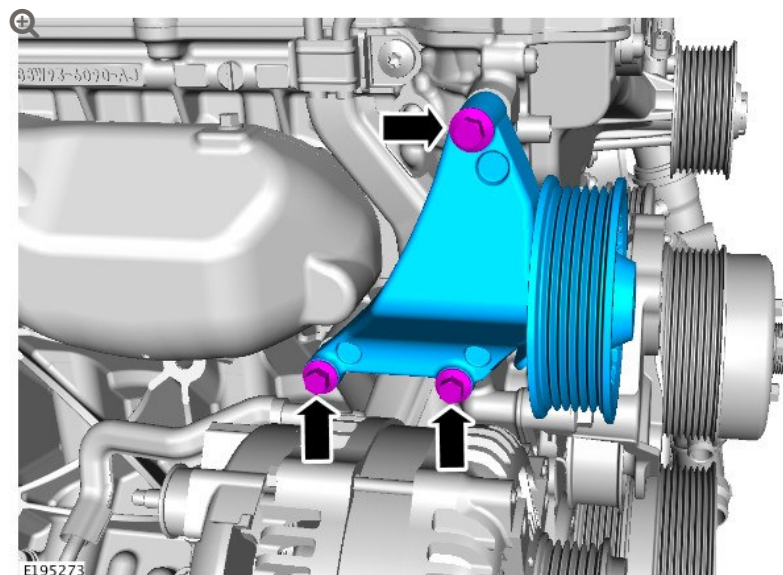

Remove the accessory drive idler pulley and bracket assembly.

4

NOTE:

The fasteners must be retained for re-use.

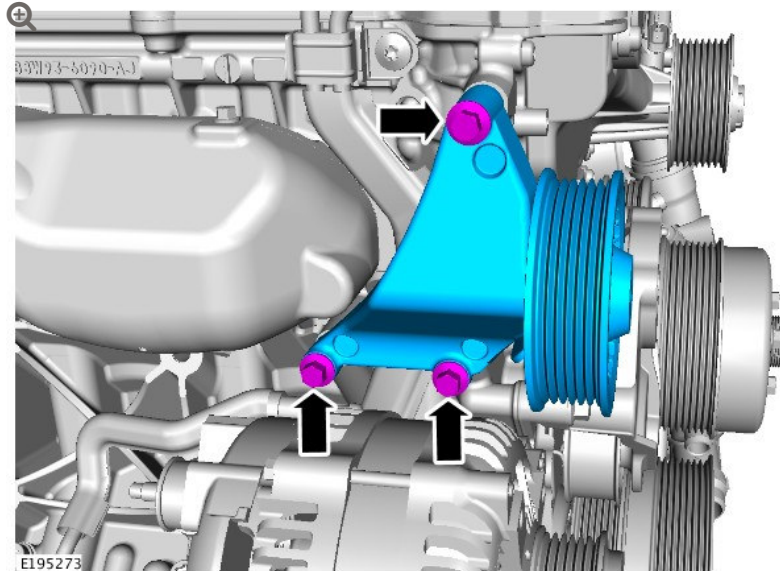

Install the new accessory drive idler pulley and bracket assembly.

- Torque: **25Nm**

5

NOTE:

Make sure that the accessory drive belt is correctly located on each pulley.

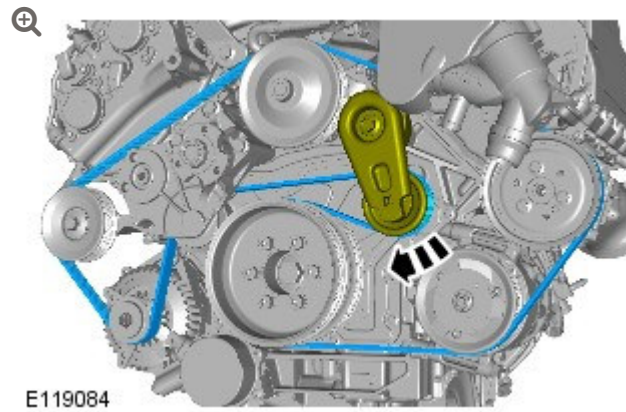

Install the accessory drive belt.

- ⊞ Install the T-connector to the air cleaner outlet pipe (see TOPIx Workshop Manual section 303-12: Intake Air Distribution and Filtering - Air Cleaner Outlet Pipe T-Connector).