

# TECHNICAL BULLETIN

## K410NAS1

### 01 NOV 2016



© Jaguar Land Rover North America, LLC

NOTE: The information in Technical Bulletins is intended for use by trained, professional Technicians with the knowledge, tools, and equipment required to do the job properly and safely. It informs these Technicians of conditions that may occur on some vehicles, or provides information that could assist in proper vehicle service. The procedures should not be performed by 'do-it-yourselfers'. If you are not a Retailer, do not assume that a condition described affects your vehicle. Contact an authorized Jaguar service facility to determine whether this bulletin applies to a specific vehicle.

### **SECTION: 303-00**

Service Action: Carbon Canister Hose Ozone Cracking

### **AFFECTED VEHICLE RANGE:**

#### **F-TYPE (X152)**

<b>Model Year:</b>	2015-2017	
<b>VIN:</b>	K15429-K39932	V6 S/C 3.0L Petrol
<b>Assembly Plant:</b>	Castle Bromwich	

#### **XE (X760)**

<b>Model Year:</b>	2017	
<b>VIN:</b>	923958-953582	GTDi 2.0L Petrol/V6 S/C 3.0L Petrol
<b>Assembly Plant:</b>	Solihull	

#### **XF (X260)**

<b>Model Year:</b>	2016-2017	
<b>VIN:</b>	Y00070-Y33900	GTDi 2.0L Petrol/V6 S/C 3.0L Petrol
<b>Assembly Plant:</b>	Castle Bromwich	

#### **XF (X250)**

<b>Model Year:</b>	2014-2015	
<b>VIN:</b>	U24391-U88782	V6 S/C 3.0L Petrol
<b>Assembly Plant:</b>	Castle Bromwich	

#### **XJ Range (X351)**

<b>Model Year:</b>	2016	
<b>VIN:</b>	V90868-W00765	V6 S/C 3.0L Petrol
<b>Assembly Plant:</b>	Castle Bromwich	

### **MARKETS:**

NAS

### **CONDITION SUMMARY:**

**Situation:** An issue has been identified on a limited number of vehicles within the listed Affected Vehicle Range where the evaporative emission canister hose may show signs of ozone cracking.

**Action:** Retailers are required to **HOLD** affected new vehicles that are within your control and refrain from releasing the vehicles for **new vehicle sale** pending completion of the Service Instruction detailed in this Technical Bulletin. Unsold vehicles should have this performed as part of the Pre-Delivery Inspection (PDI) process but **must** have it completed prior to vehicle handover to the customer.

Affected vehicles already in the hands of customers should be updated at the next available opportunity.

### **PARTS:**



**NOTE: Order only the expected percentage demand of parts identified.**

DESCRIPTION	PART No./SUNDRY CODE	QTY./VALUE	EXPECTED % of VEHICLES REQUIRING PARTS
Hose - F-TYPE (X152)	T2R11439	1	100
Hose - XE (X760), XF (X260)	T2H6976	1	100
Hose - XF (X250)	C2Z29122	1	100
Hose - XJ (X351)	C2Z29121	1	100

### **SPECIAL TOOLS:**

Refer to Workshop Manual/Service Instruction for any required special tools

### **WARRANTY:**



**NOTE: Check DDW to ensure that a vehicle is affected by this program prior to undertaking any rework action.**

At the time of confirming a booking for vehicle repair, ensure that **all** outstanding Recalls and Service Actions are identified to ensure the correct parts are available and adequate workshop time is allocated for repairs to be completed at one visit.

Warranty claims must be submitted quoting Program Code '**K410**', Option Code '**X**', and the relevant SRO and parts information. The SRO that allows for the drive in / drive out allowance can only be claimed if the vehicle is brought back into the workshop for this action alone to be undertaken.

This program is valid for a limited time only. Warranty claims with a repair date prior to the **31 October 2018** closure date must be submitted or payment within 30 calendar days of completion of the repair.

Repair procedures are under constant review and therefore times / prices are subject to change; those quoted here must be taken as guidance only. Refer to TOPIx to obtain the latest repair time.

DESCRIPTION	SRO	TIME (HOURS)
Secondary evaporative emission canister hose removal for access - F-TYPE(X152; Coupe)	17.15.56	0.90
Secondary evaporative emission canister hose removal for access - F-TYPE(X152; Folding top)	17.15.56.99	0.60
Secondary evaporative emission canister hose removal for access - XE (X760), XF (X260)	17.15.56	0.40
Secondary evaporative emission canister hose removal for access - XJ (X351), XF (X250)	17.15.56	0.30
Secondary evaporative emission canister hose with removed access - Renew - All	17.15.57	0.10
Read and Clear DTC - All	86.99.78	0.20
Drive in/drive out - All	10.10.10	0.20

Normal Warranty policies and procedures apply.

### **SERVICE INSTRUCTION A - F-TYPE (X152) ONLY**

1. Access the evaporative emission canister (see TOPIx Workshop Manual section 303-13: Evaporative Emission - Evaporative Emission Canister [steps 1-7 only]).
2. Release the tension from the evaporative emission canister hose fasteners and move the fasteners towards the center of the pipe.

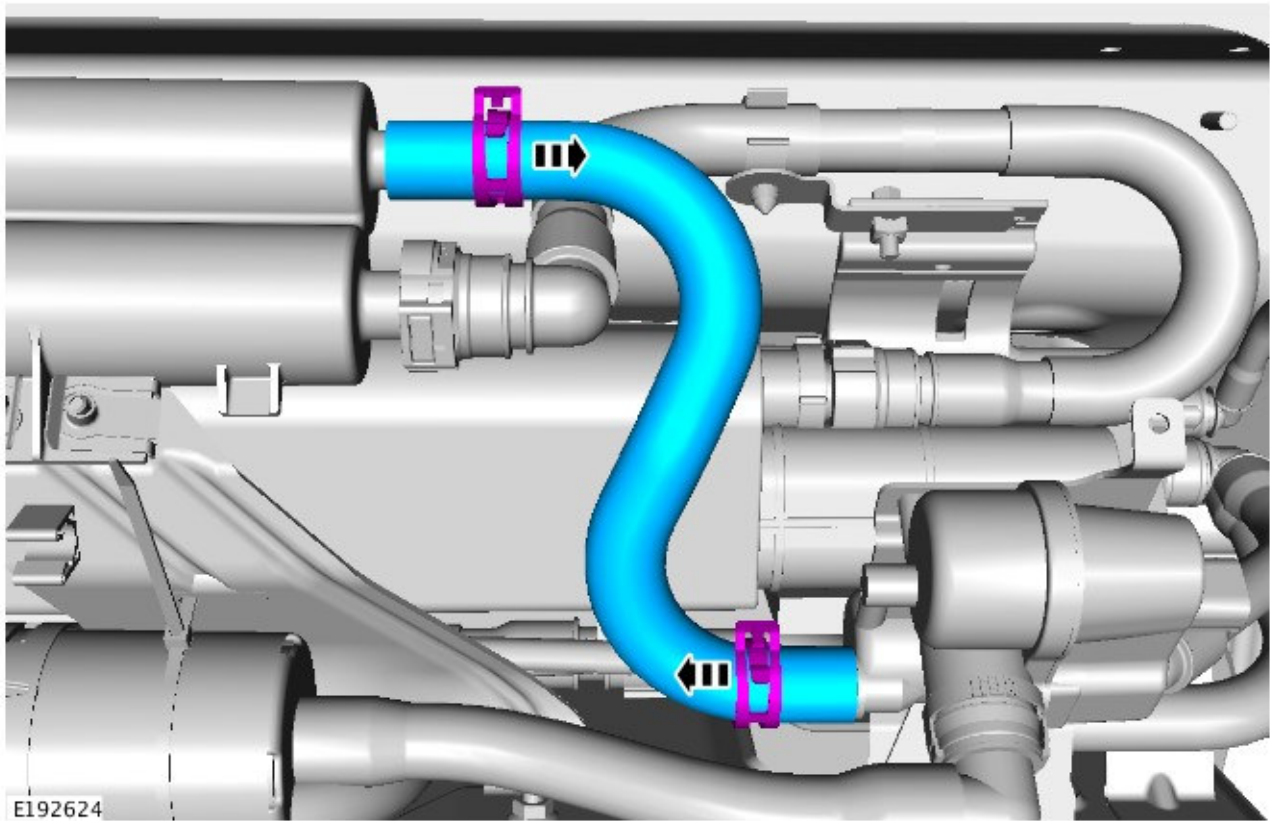

3.  **NOTE: The evaporative emission canister hose fasteners must be reused to install the new evaporative emission canister hose.**

Remove and discard the evaporative emission canister hose.

- Do not discard the hose fasteners.

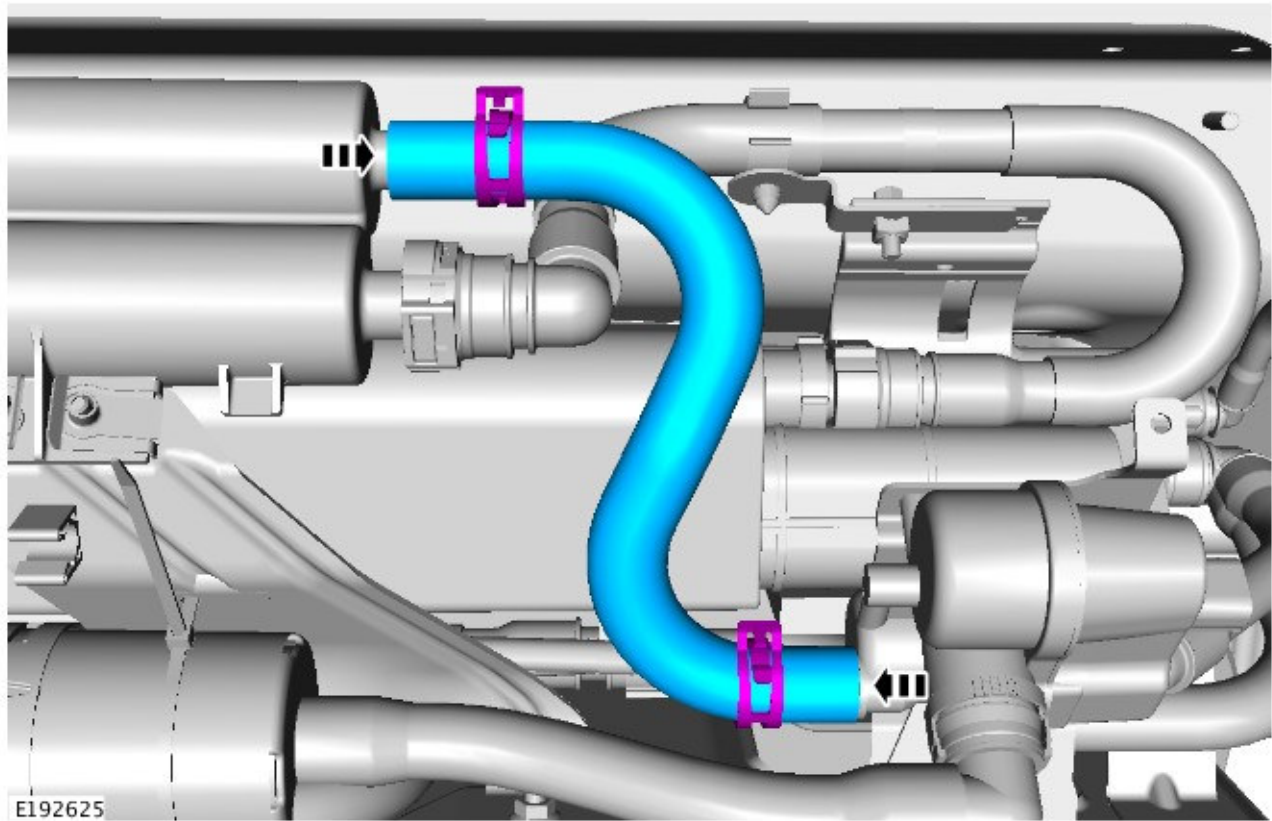

**4.** Install the original evaporative emission canister hose fasteners onto the new evaporative emission canister hose.

**5.** Install the new evaporative emission canister hose.

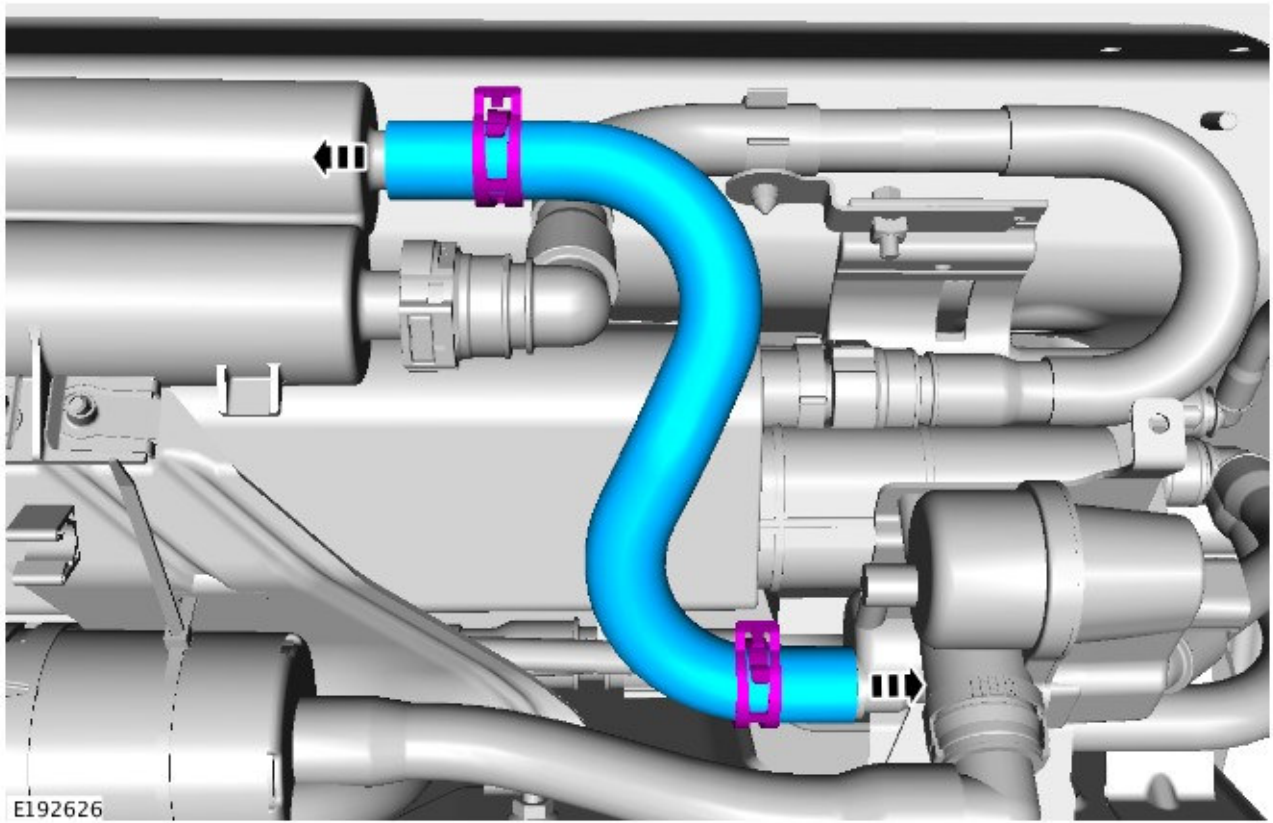

6. Install the evaporative emission canister hose fasteners into their final position.

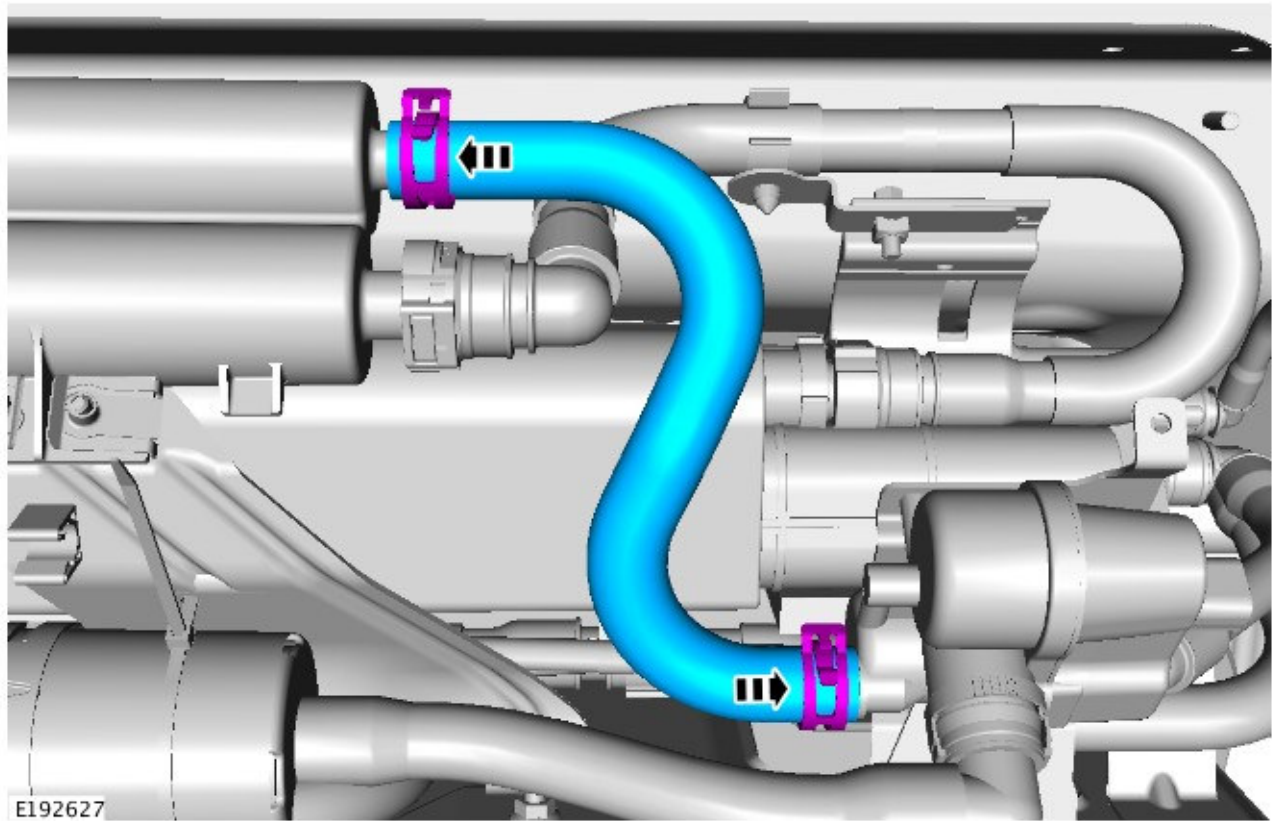

7. Reverse the evaporative emission canister access procedure (see TOPIx Workshop Manual section 303-13: Evaporative Emission - Evaporative Emission Canister [steps 7-1]).

**SERVICE INSTRUCTION B - XE (X760), XF (X260) ONLY**

1. Remove the rear left wheel (see TOPIx Workshop Manual section 204-04: Wheels and Tires, Removal and Installation).
2. Remove the rear left wheel arch liner.



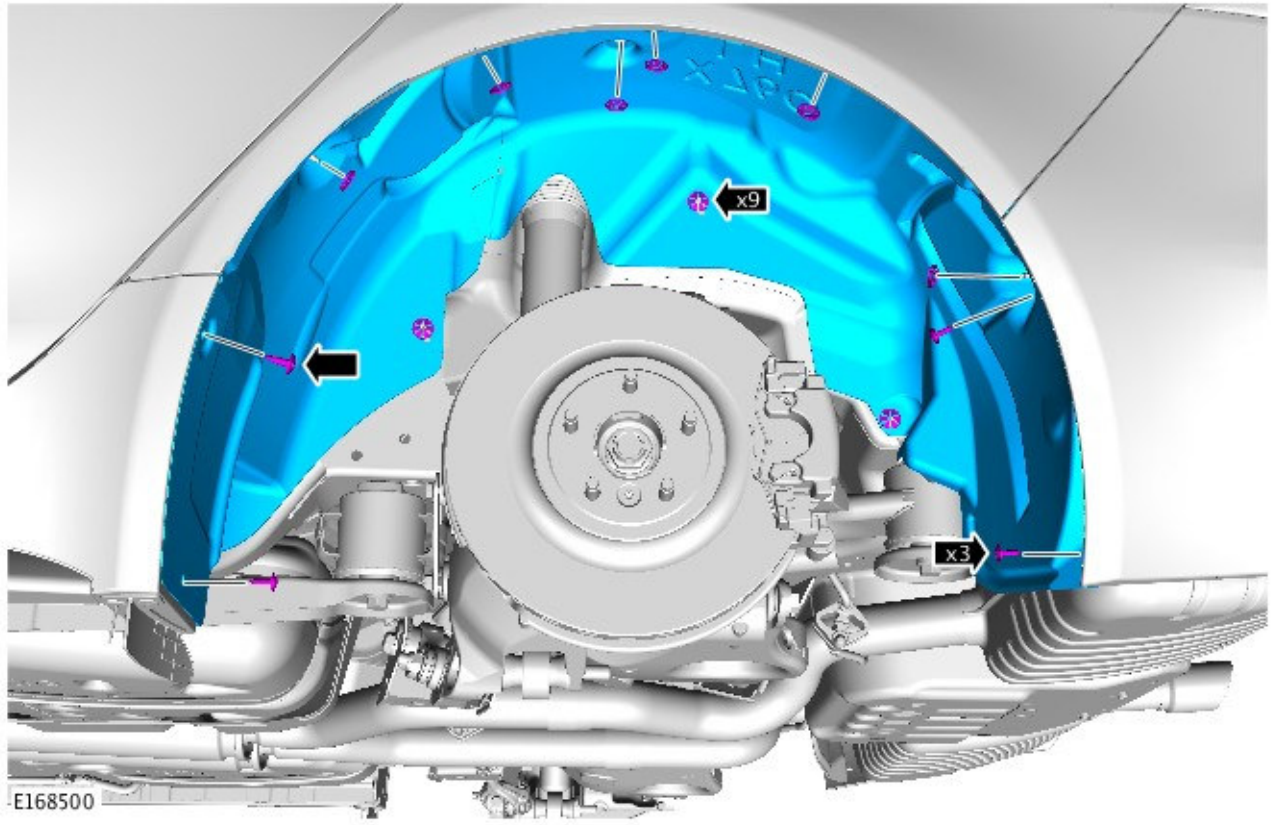

3. Remove the connector and fastener.

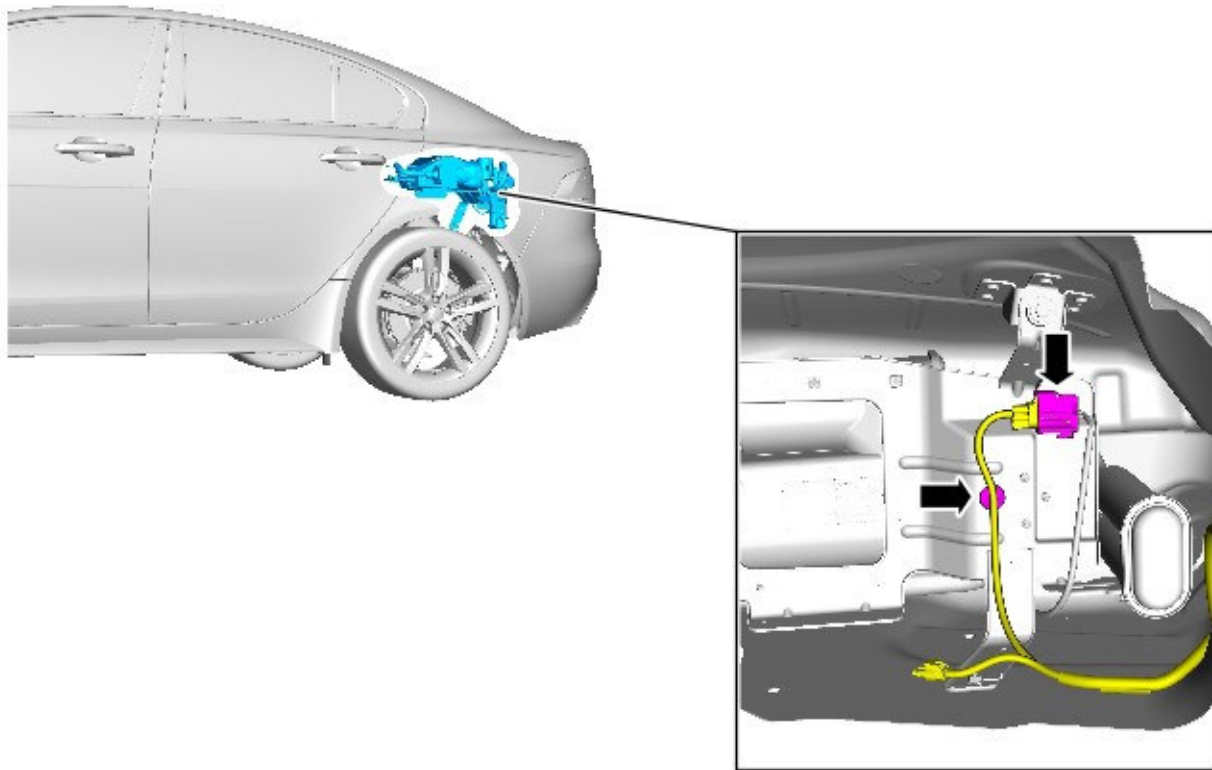

E168513

4. Remove the evaporative emission canister assembly.



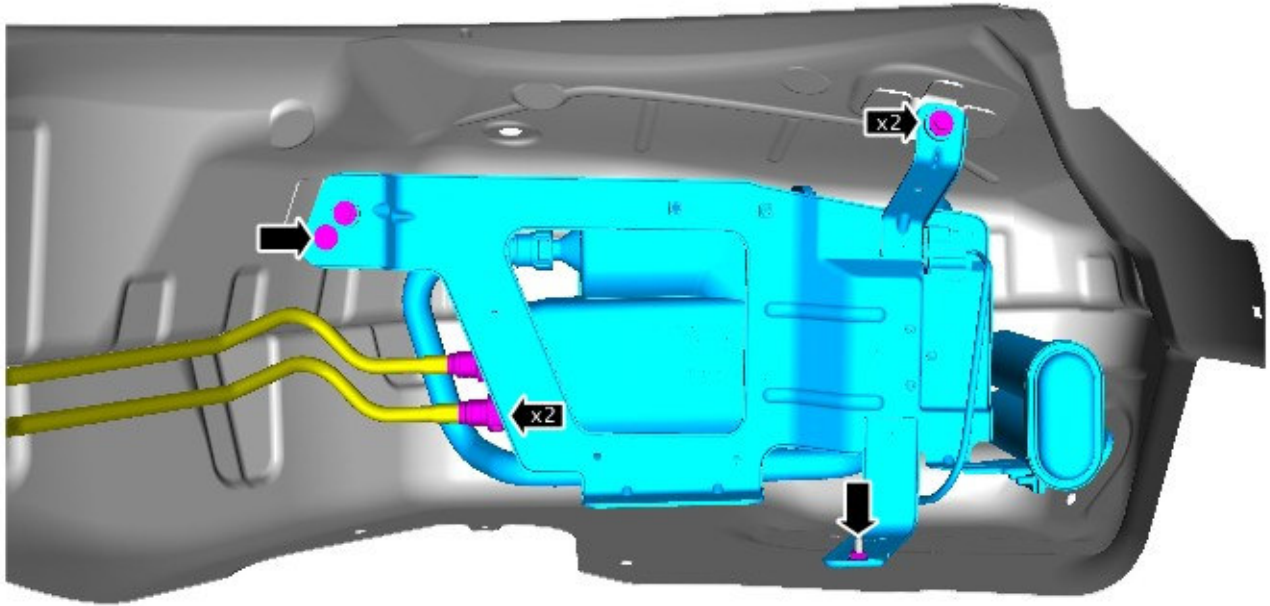

E168514

5.  **NOTE: The evaporative emission canister hose fasteners must be reused to install the new evaporative emission canister hose.**

Remove and discard the evaporative emission canister hose.

- Do not discard the hose fasteners.

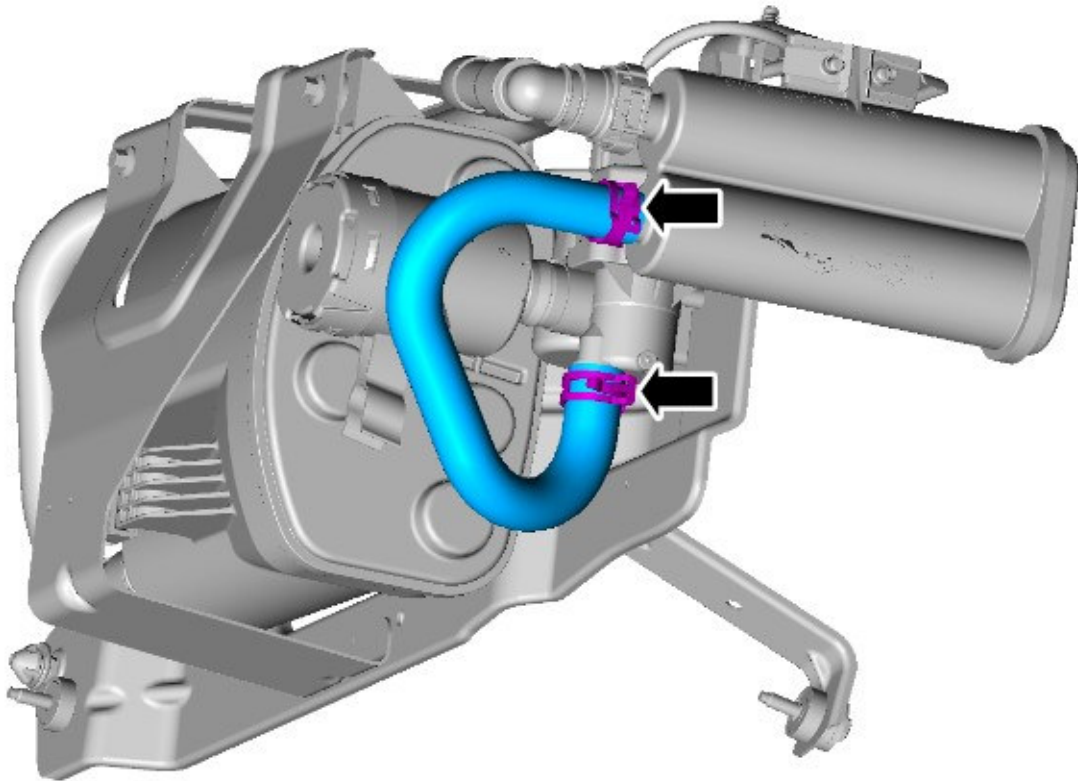

E198813

6. Install the original evaporative emission canister hose fasteners onto the new evaporative emission canister hose.

7.  **NOTE: The evaporative emission canister hose fasteners must be reused to install the new evaporative emission canister hose.**

Install the new evaporative emission canister hose.

1. Install the evaporative emission canister hose fasteners into their final position.

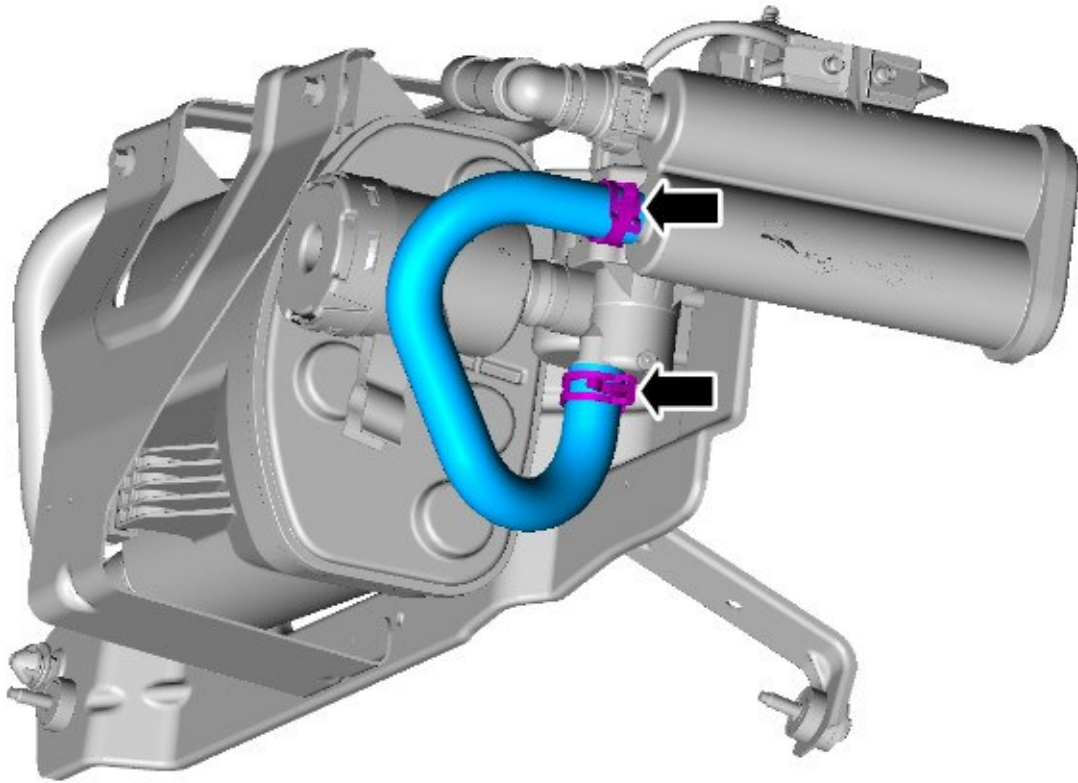

E198813

8. Install the evaporative emission canister assembly.

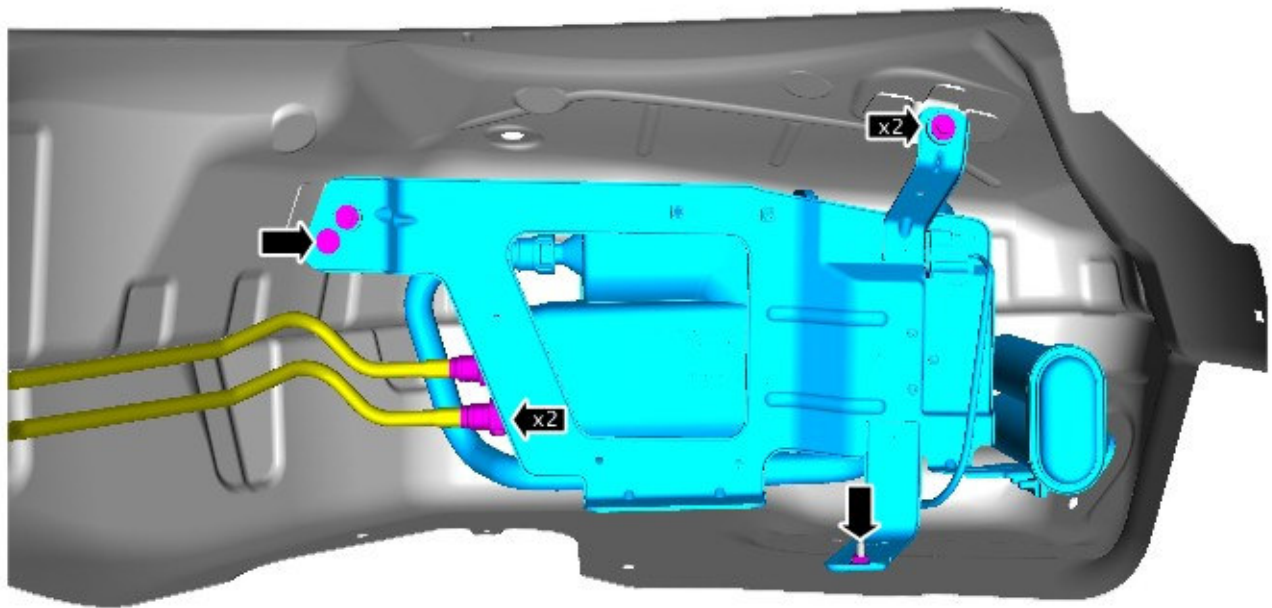

E168514

9. Install the connector and fastener.

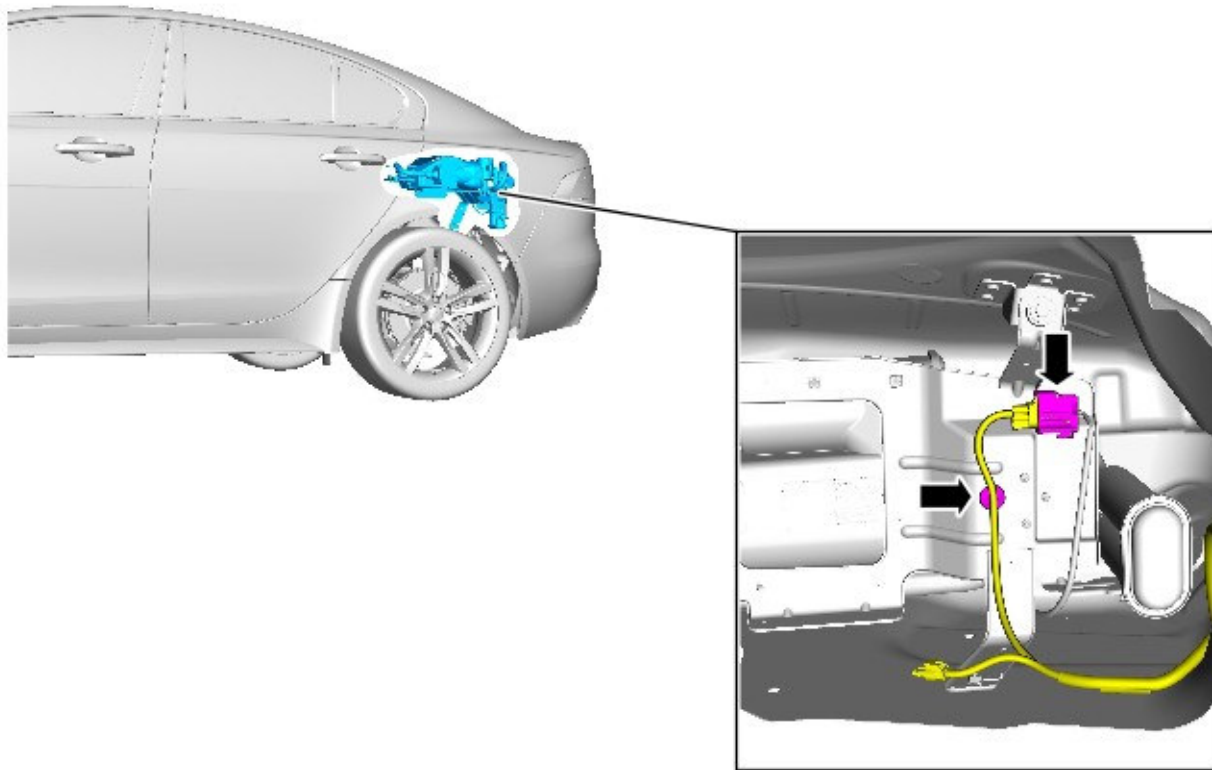

E168513

**10.** Install the rear left wheel arch liner.

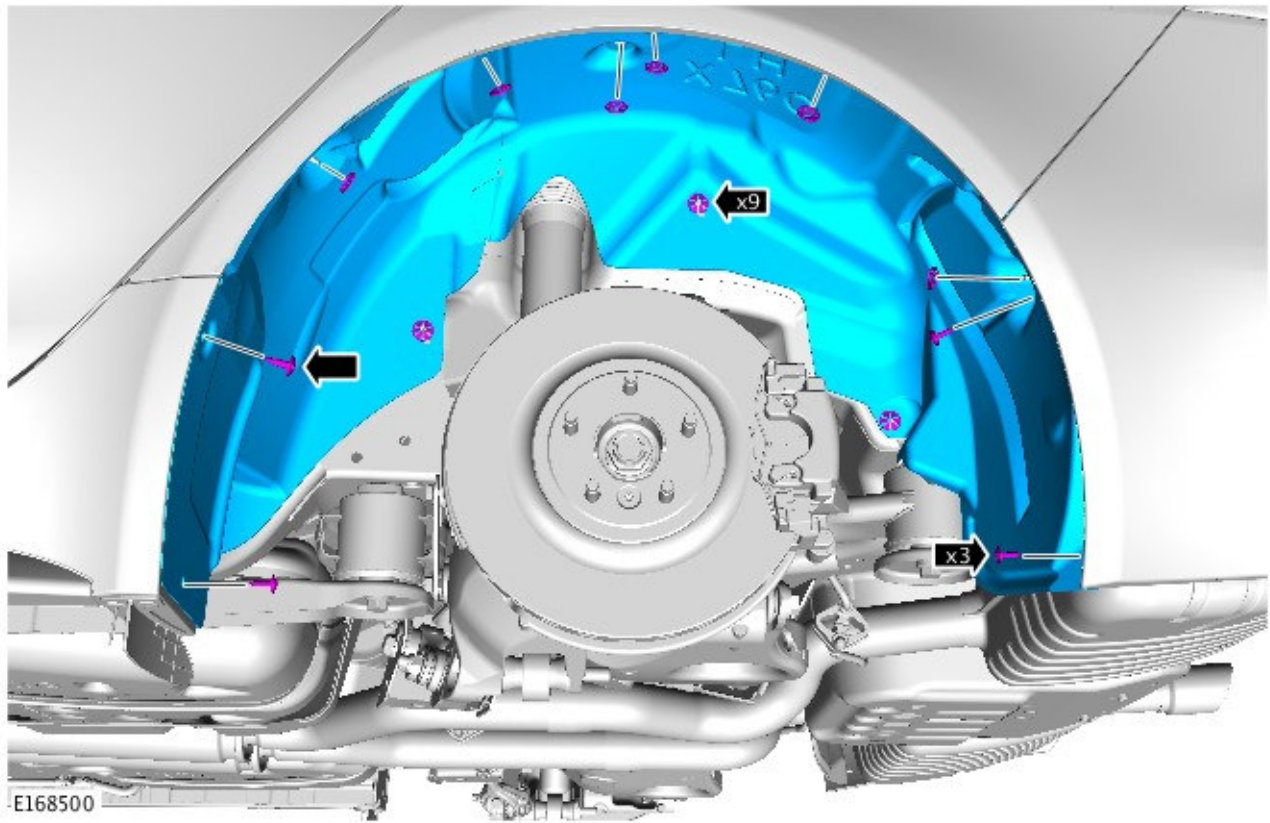

11. Install the rear left wheel (see TOPIx Workshop Manual section 204-04: Wheels and Tires, Removal and Installation).

### **SERVICE INSTRUCTION C - XF (X250) ONLY**

1. Remove the rear right wheel (see TOPIx Workshop Manual section 204-04: Wheels and Tires, Removal and Installation).
2. Remove the rear right wheel arch liner.

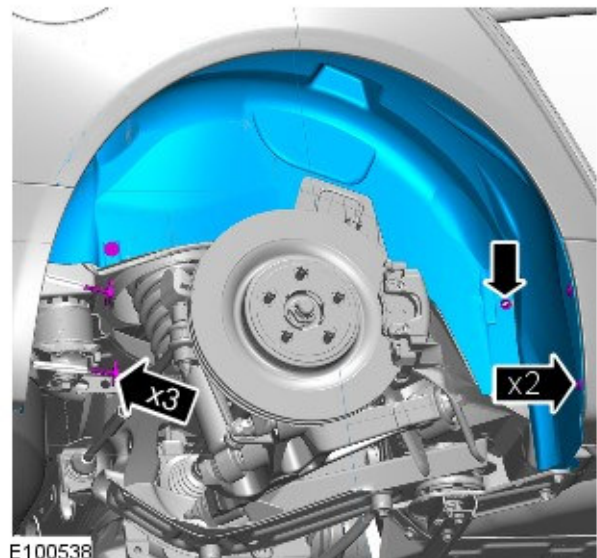



**3.** Remove the pipe.

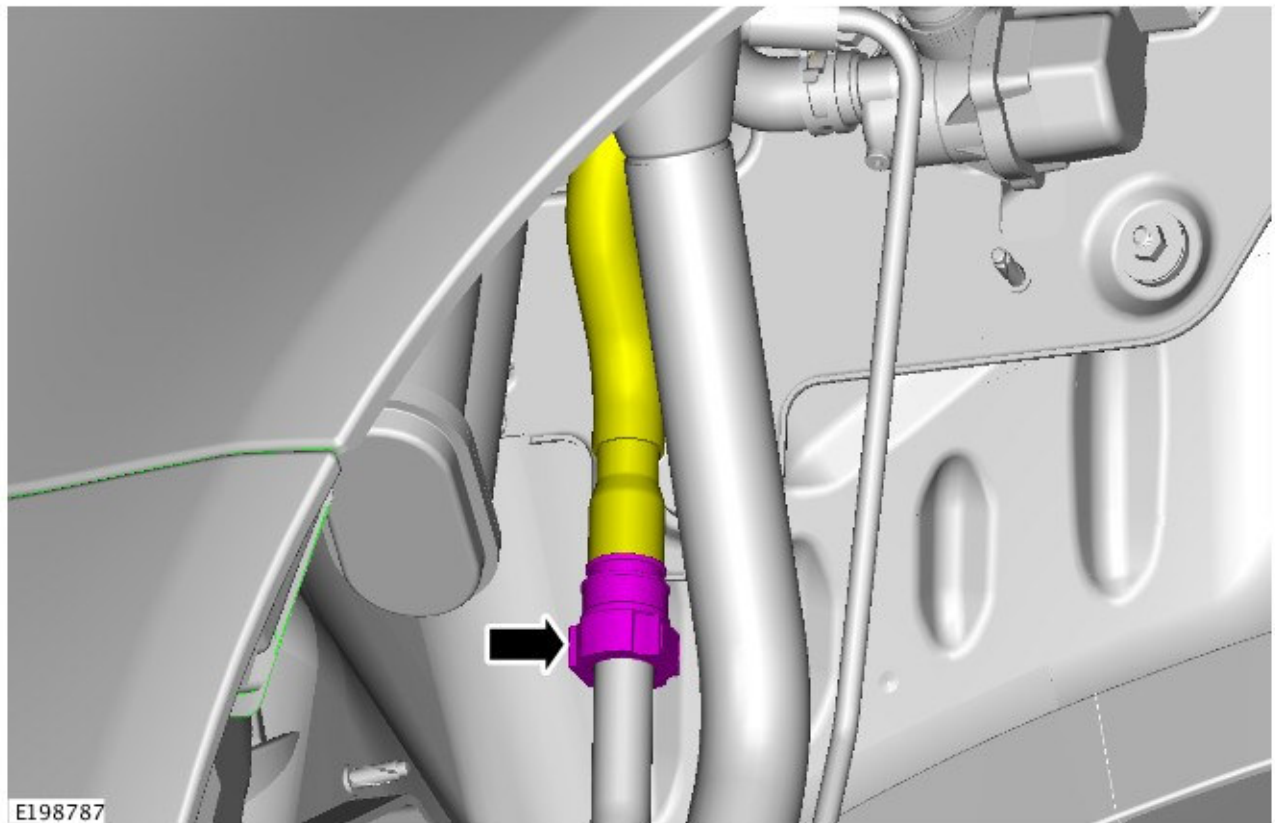

**4.** Remove the connector and fastener.



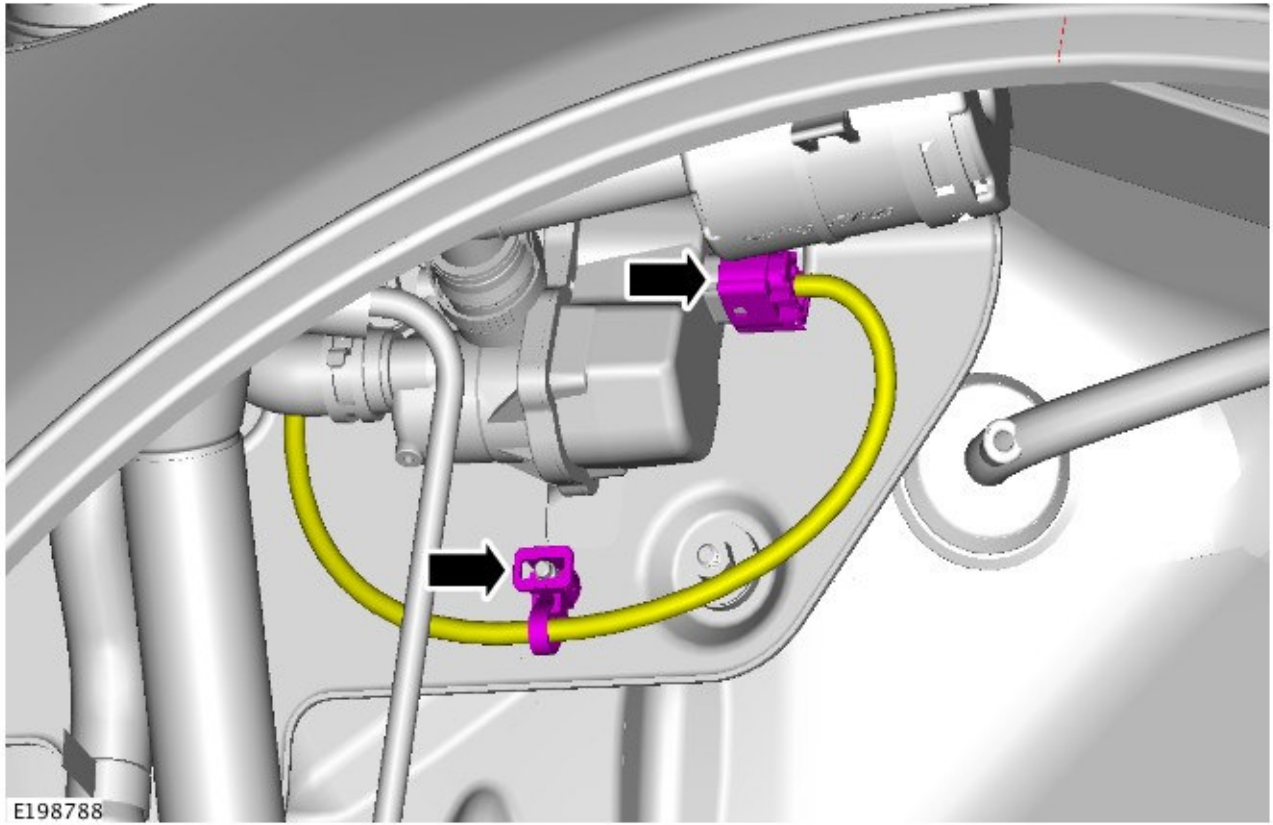

5. Remove the evaporative emission canister assembly.

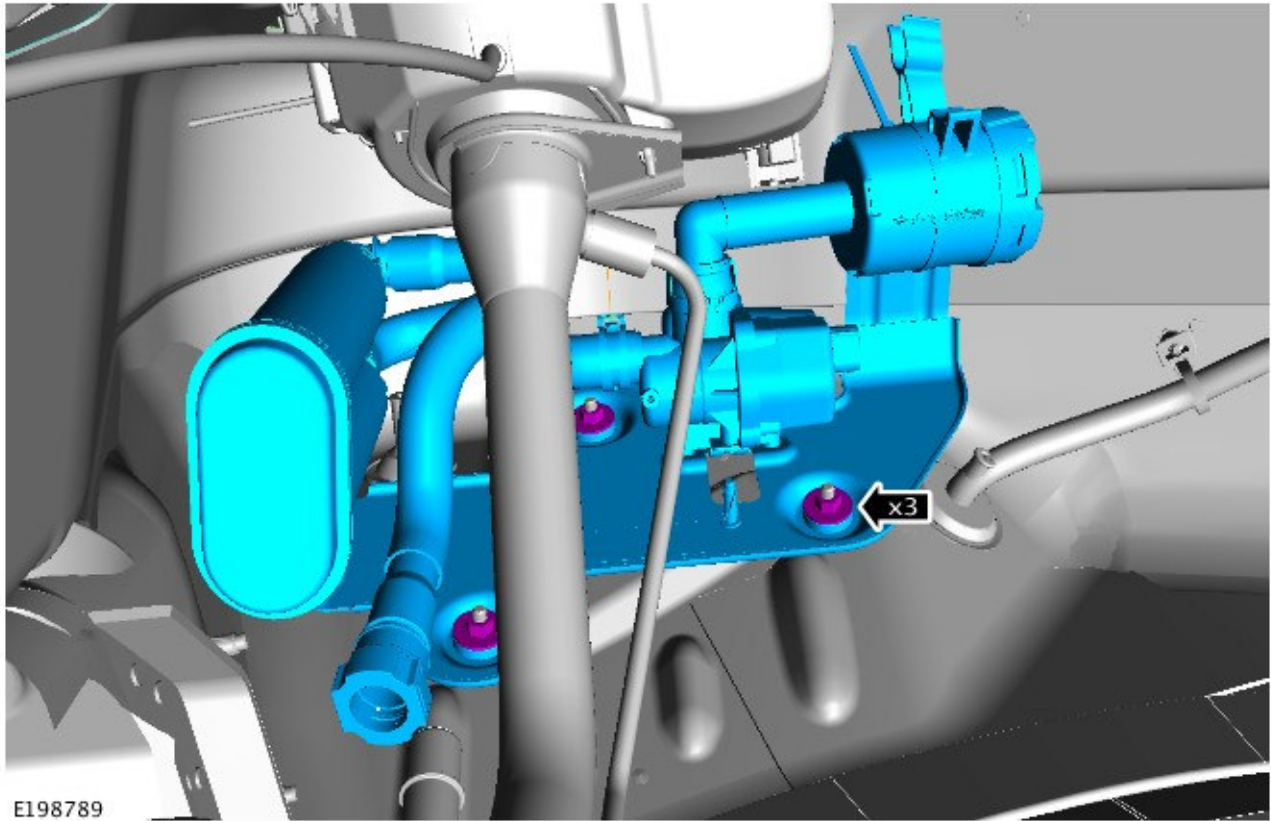

6.  **NOTE: The evaporative emission canister hose fasteners must be reused to install the new evaporative emission canister hose.**

Remove and discard the evaporative emission canister hose.

- Do not discard the hose fasteners.

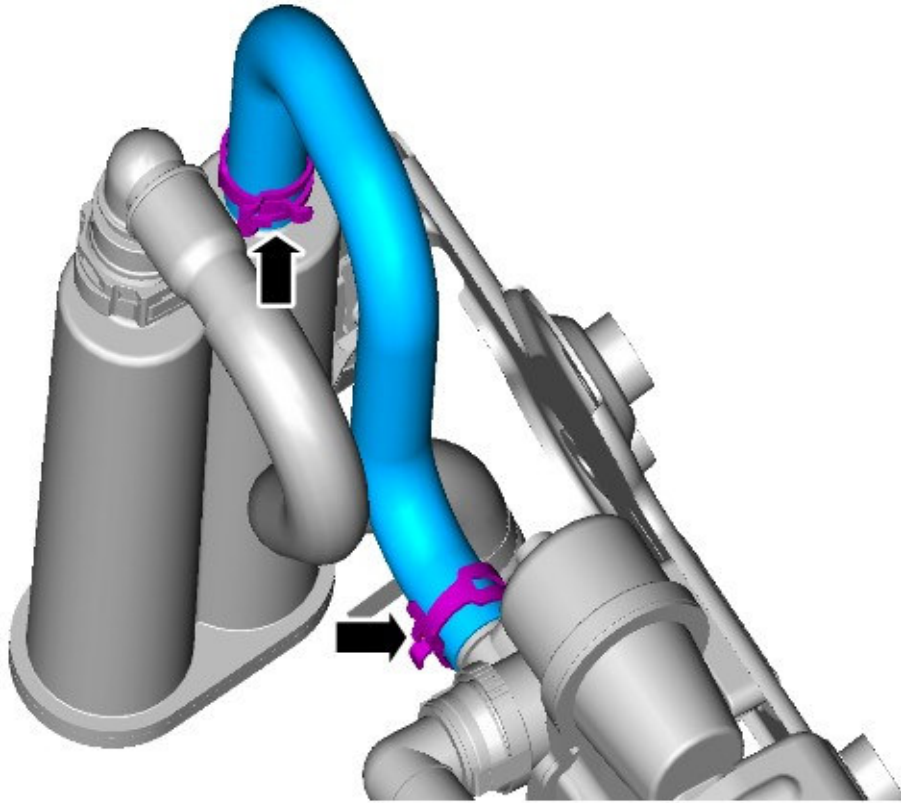

E198790

7. Install the original evaporative emission canister hose fasteners onto the new evaporative emission canister hose.

8.  **NOTE: The evaporative emission canister hose fasteners must be reused to install the new evaporative emission canister hose.**

Install the new evaporative emission canister hose.

1. Install the evaporative emission canister hose fasteners into their final position.

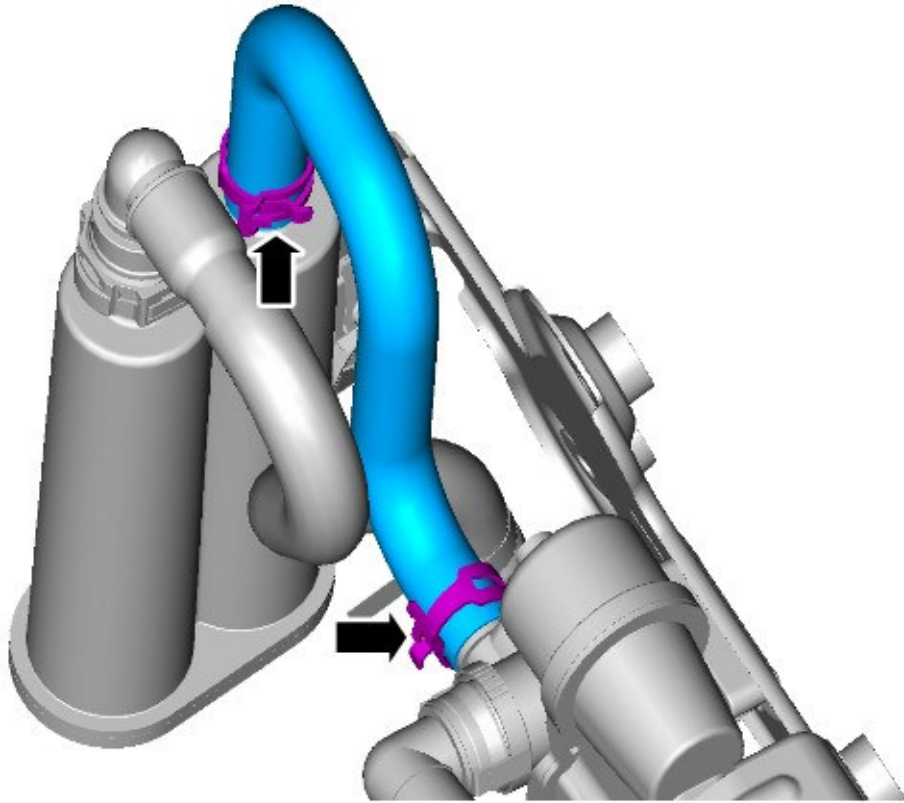

E198790

9. Install the evaporative emission canister assembly.

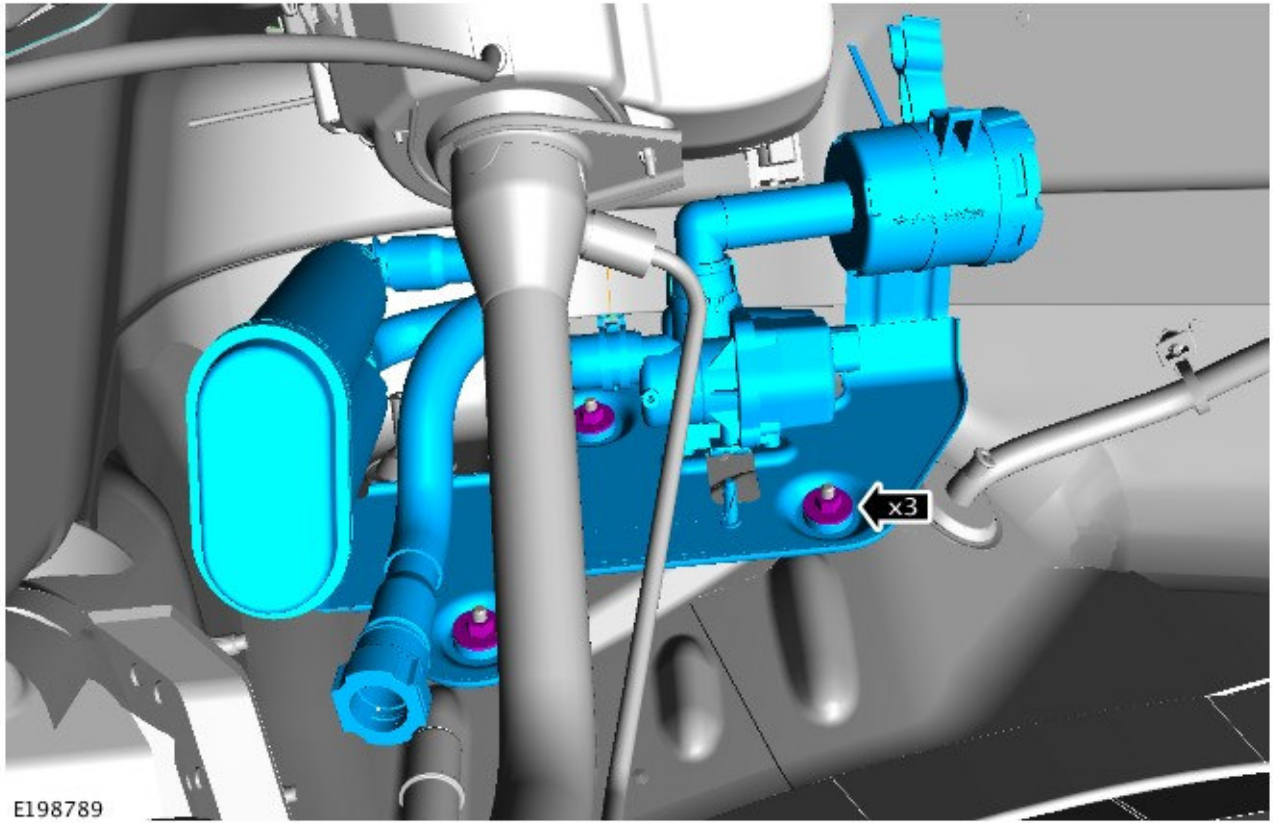

10. Install the connector and fastener.

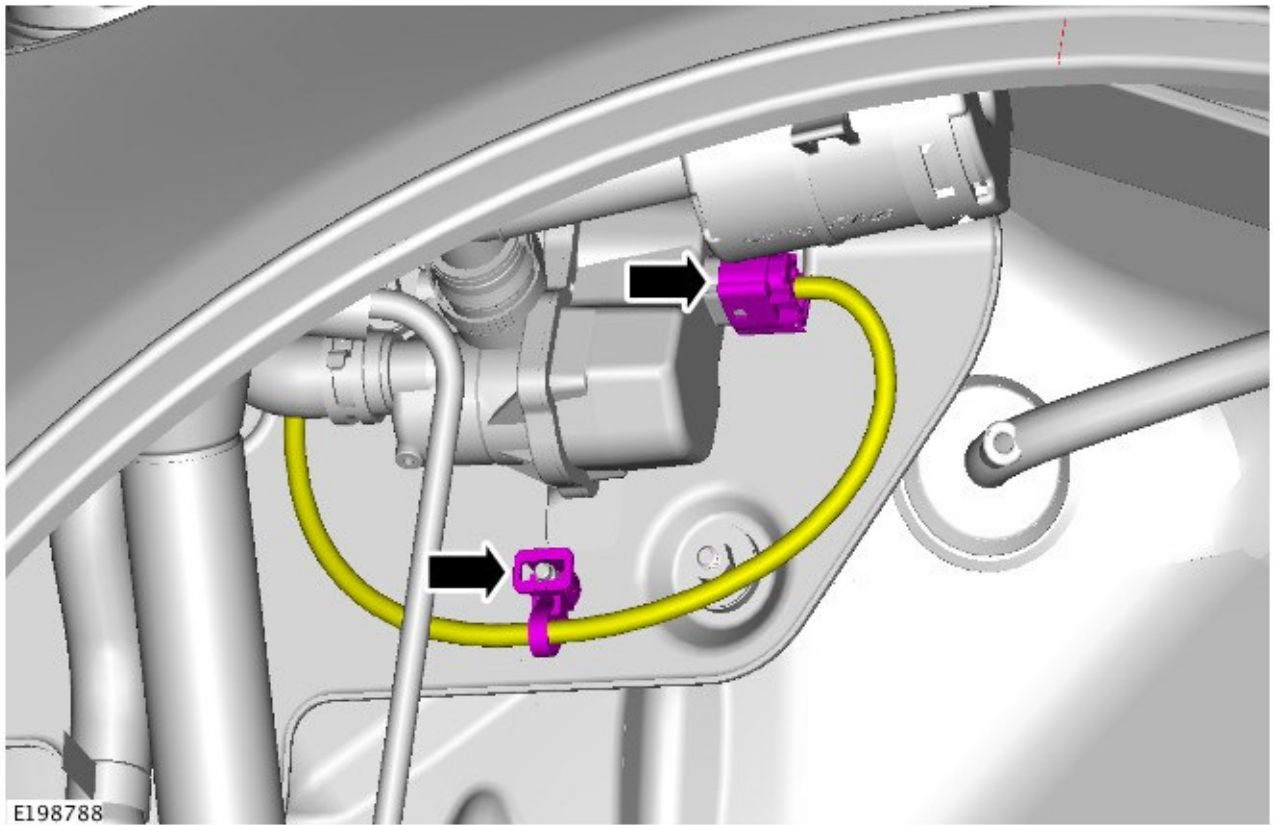

**11.** Install the pipe.



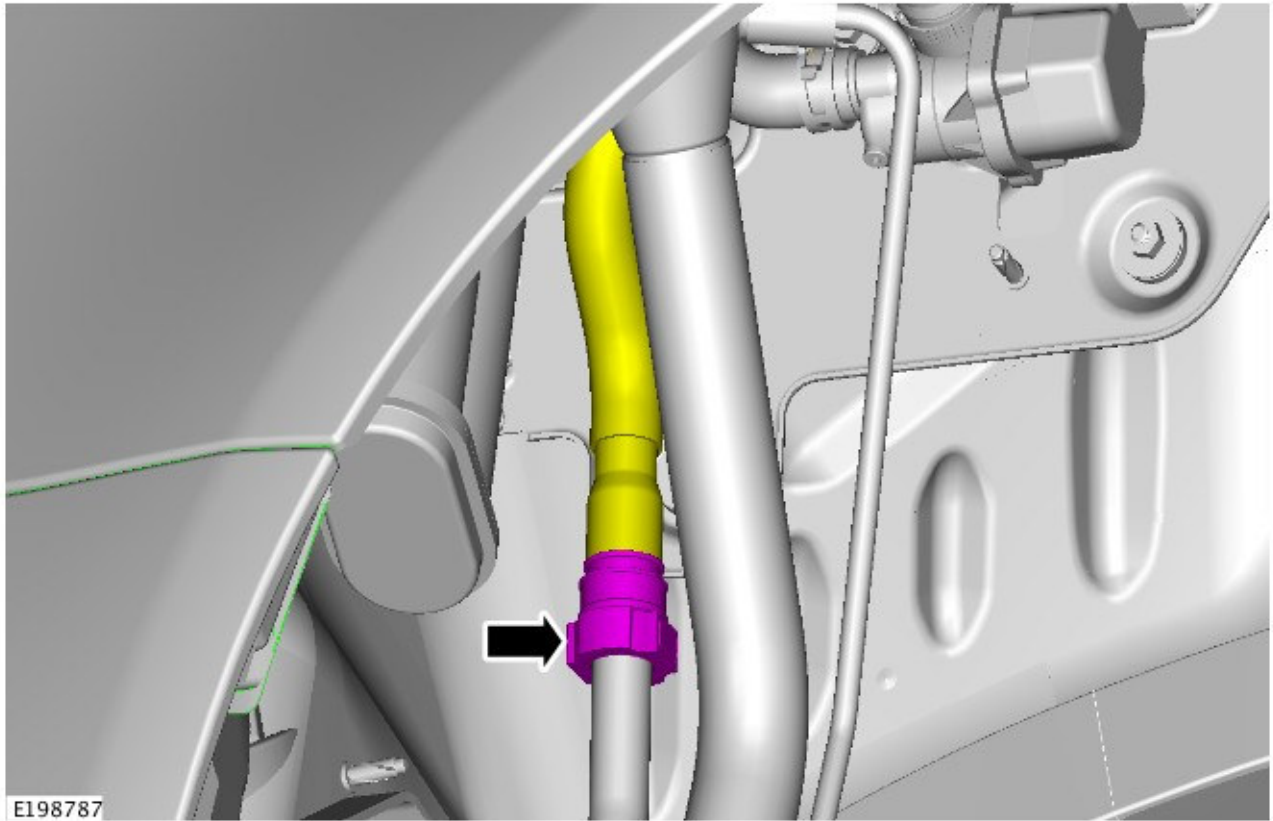

12. Install the rear right wheel arch liner.

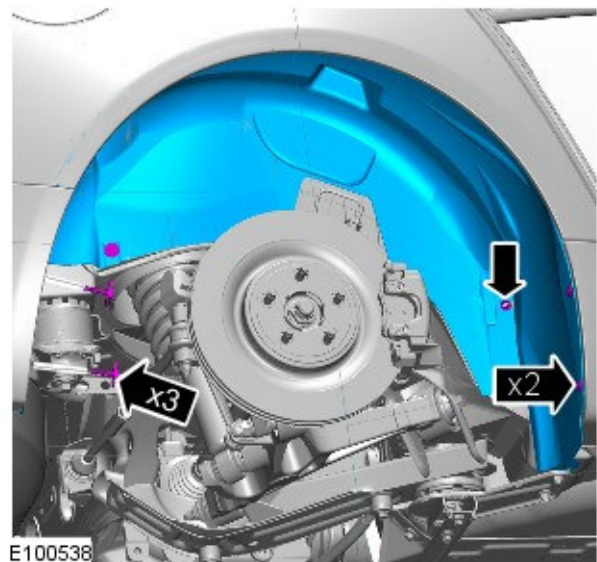

13. Install the rear right wheel (see TOPIX Workshop Manual section 204-04: Wheels and Tires, Removal and Installation).

**SERVICE INSTRUCTION D - XJ (X351) ONLY**



1. Remove the rear right wheel (see TOPIX Workshop Manual section 204-04: Wheels and Tires, Removal and Installation).
2. Remove the rear left wheel arch liner.

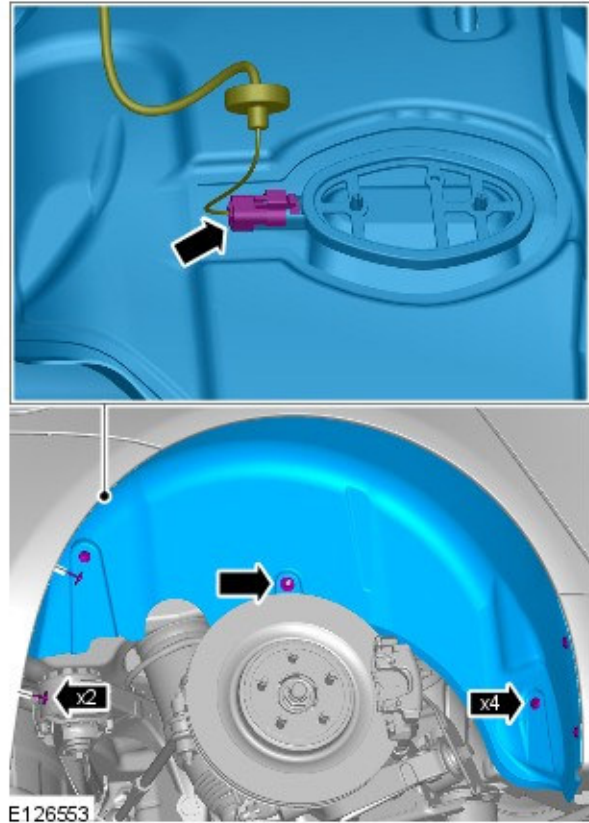

3.  **NOTE: The evaporative emission canister hose fasteners must be reused to install the new evaporative emission canister hose.**

Remove and discard the evaporative emission canister hose.

- Do not discard the hose fasteners.

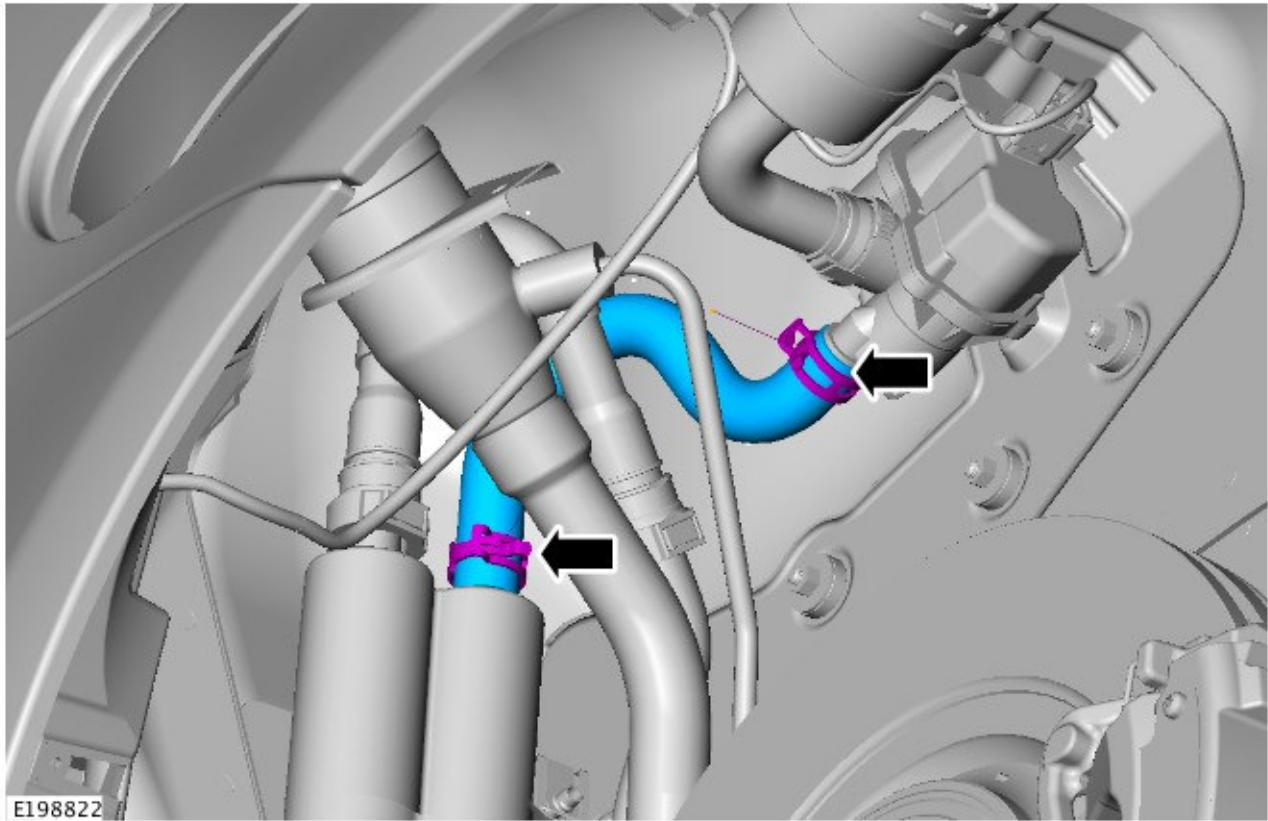

4. Install the original evaporative emission canister hose fasteners onto the new evaporative emission canister hose.

5.  **NOTE: The evaporative emission canister hose fasteners must be reused to install the new evaporative emission canister hose.**

Install the new evaporative emission canister hose.

1. Install the evaporative emission canister hose fasteners into their final position.

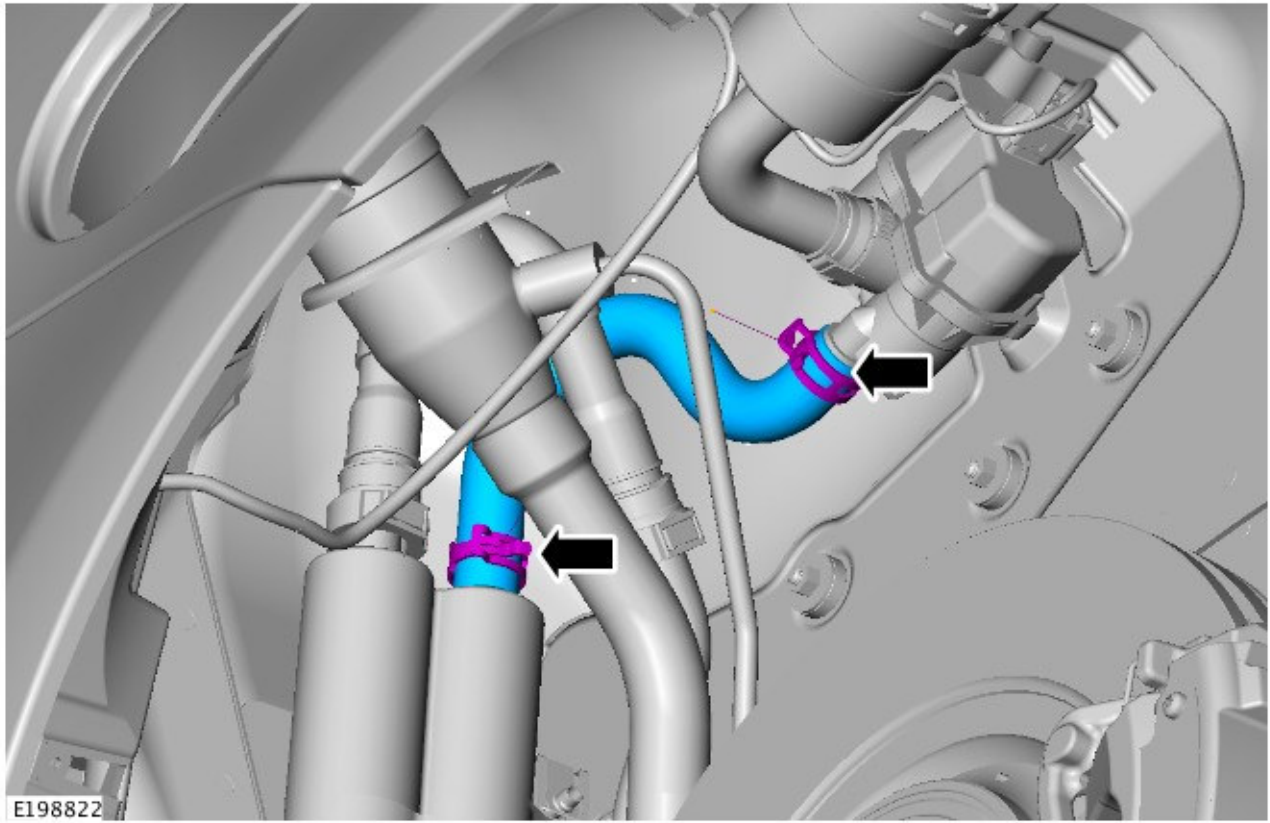

6. Install the rear left wheel arch liner.

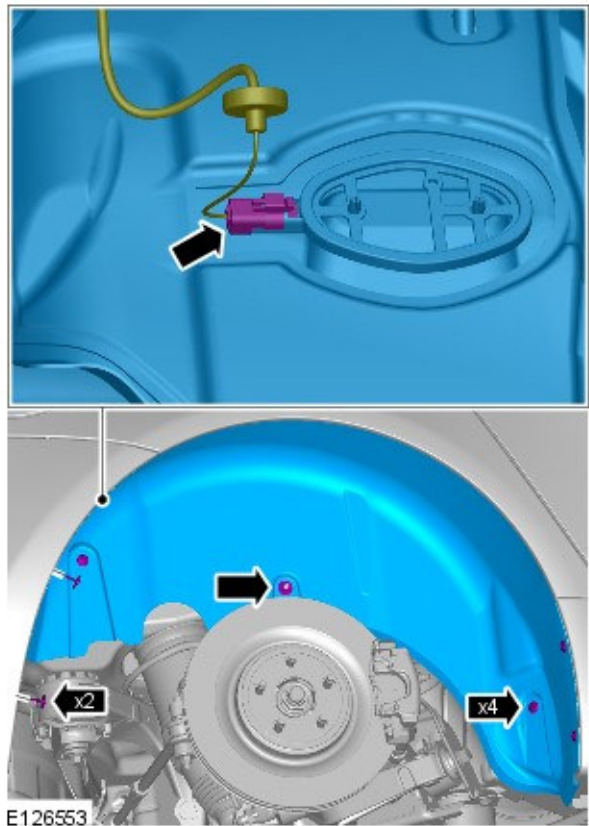

7. Install the rear right wheel (see TOPIx Workshop Manual section 204-04: Wheels and Tires, Removal and Installation).