

# 2AZ-FE Engine Oil Consumption

Service Category Engine/Hybrid System

Section Engine Mechanical

Market USA

Toyota Supports  
 ASE Certification 

## Applicability

YEAR(S)	MODEL(S)	ADDITIONAL INFORMATION
2007 – 2011	Camry HV	Engine(s): 2AZ VDS(s): BB3EK, BB46K
2007 – 2009	Camry	Engine(s): 2AZ VDS(s): BE46K
2009	Corolla	Engine(s): 2AZ VDS(s): BE40E
2009	Matrix	Engine(s): 2AZ VDS(s): GE40E, KE40E, LE40E
2006 – 2008	RAV4	Engine(s): 2AZ VDS(s): BD31V, BD32V, BD33V, BD34V, BD35V, ZD31V, ZD32V, ZD33V, ZD34V, ZD35V
2007 – 2008	Solara	Engine(s): 2AZ VDS(s): CE30P

### REVISION NOTICE

January 29, 2015 Rev1:

- The Warranty Information, Parts Information, and Repair Procedure sections have been updated.
- The Inspection Procedure has been removed and is now published in a separate bulletin ([T-SB-0158-14](#)).

All previous printed versions of this bulletin should be discarded.

## Introduction

### NOTE

Service Bulletin No. [T-SB-0158-14](#), "2AZ-FE Engine Oil Consumption Inspection Procedure," MUST be performed first **BEFORE** continuing with the procedure in this bulletin.

## 2AZ-FE Engine Oil Consumption

### Introduction (Continued)

Some 2006 – 2011 model year vehicles equipped with the 2AZ-FE engine may exhibit engine oil consumption. The piston assembly has been changed to minimize oil consumption. Use the following Repair Procedure to address this condition.

### Production Change Information

This bulletin applies to:

- ALL 2007 – 2008 MY Solara vehicles.
- Vehicles produced **BEFORE** the Production Change Effective VINs shown below.

MODEL	DRIVETRAIN	PLANT	PRODUCTION CHANGE EFFECTIVE VIN
Camry	2AZ-FE	TMMK Line 1	4T1BE46K#9U402467
		TMMK Line 2	4T1BE46K#9U916988
		SIA	4T4BE46K#9R131092
		Tsutsumi	JTNBE46K#93174340
Camry HV	2AZ-FXE	TMMK	4T1BB##K#BU138556
		Tsutsumi	JTNBB##K#B3054292
Corolla	2AZ-FE	NUMMI	1NXBE40E#9Z087463
Matrix		TMMC	2T1BE40E#9C026707
RAV4		TMMC	2T1#E40E#9C010829
		Tahara	JTM#D3#V#85209466
		Shokki	JTM#D3#V#86088135

### Warranty Information

OP CODE	DESCRIPTION	MODEL	ENGINE	DRIVE-TRAIN	TIME	OFP	T1	T2
EG9014	R & R Piston and Ring Set	Camry	2AZ-FE	-	14.8	13211-0H040-A0 13211-0H040-B0 13211-0H040-C0 13211-0H041-A0 13211-0H041-B0 13211-0H041-C0 13211-28110-A0 13211-28110-B0 13211-28110-C0 13211-28111-A0 13211-28111-B0 13211-28111-C0 13211-28112-A0 13211-28112-B0 13211-28112-C0	11	99

## 2AZ-FE Engine Oil Consumption

### Warranty Information (Continued)

OP CODE	DESCRIPTION	MODEL	ENGINE	DRIVE-TRAIN	TIME	OFF	T1	T2
EG9014	R & R Piston and Ring Set	Camry HV	2AZ-FXE	-	15.5	13211-28120-A0 13211-28120-B0 13211-28120-C0 13211-28121-A0 13211-28121-B0 13211-28121-C0	11	99
		Corolla	2AZ-FE	-	14.2	13211-28110-A0 13211-28110-B0		
		Matrix		2WD	14.2	13211-28110-C0 13211-28111-A0		
				4WD	14.7	13211-28111-B0 13211-28111-C0		
		RAV4		2WD	15.6	13211-28112-A0 13211-28112-B0		
				4WD	16.3	13211-28112-C0		
		Solara		-	16.3	13211-0H040-A0 13211-0H040-B0 13211-0H040-C0 13211-0H041-A0 13211-0H041-B0 13211-0H041-C0		

#### APPLICABLE WARRANTY

- This repair is covered under the Toyota Powertrain Warranty. This warranty is in effect for 60 months or 60,000 miles, whichever occurs first, from the vehicle's in-service date.
- Warranty application is limited to occurrence of the specified condition described in this bulletin.

### Parts Information

#### Required Kit Part Numbers

MODEL	KIT PART NUMBER	KIT PART NAME*	QTY
Camry	04004-11228	Repair Kit, Piston Ring	1
Camry HV	04004-11428		1
Corolla	04004-11628		1
Matrix	04004-11728		1
RAV4	04004-11828		1
Solara	04004-12228		1

\* See Kit Contents table for individual parts included in each kit.

## 2AZ-FE Engine Oil Consumption

### Parts Information (Continued)

#### Additional Required Parts

MODEL	PART NUMBER	PART NAME	QTY
ALL	90915-YZZF1	Filter, Oil	1
ALL (except Camry HV)	04004-79128-#0	Piston	4
Camry HV	13211-28150-#0	Piston	4
Camry (PZEV Only)	17177-28040	Gasket, Intake Manifold to Head	1
	17171-28020	Gasket, Intake Manifold to Exhaust Manifold Intake Runner	1

#### Additional Parts: Only As Needed

MODEL	PART NUMBER	PART NAME	QTY
ALL	13251-0H030-#0	Pin, Piston	As Needed
	13201-09790-#0	Rod Sub-assy, Connecting	
	13201-29686-#0		
	13281-0H031-0#	Bearing, Connecting Rod	8 (if Needed)

#### Kit Contents

MODEL		Camry	Camry HV	Corolla	Matrix	RAV4
KIT PART NUMBER		04004-11228	04004-11428	04004-11628	04004-11728	04004-11828
PART NUMBER	PART NAME	QUANTITY (per Kit)				
13011-28260	Ring Set, Piston	1	1	1	1	1
15708-28011	Nozzle Sub-assy, Oil, No.1	4	4	4	4	4
11115-28040	Gasket, Cylinder Head	1	1	1	1	1
11213-28021	Gasket, Cylinder Head Cover	1	1	1	1	1
12157-10010	Gasket (for Transfer Drain Plug) / Gasket, No. 2 (for Transfer Case)	-	-	-	2	2
13552-28010	Gasket (for Chain Tensioner)	1	1	1	1	1
16258-28040	Gasket (for Oil Cooler Pipe Union Bolt)	1	-	1	-	-
17173-28010	Gasket, Exhaust Manifold	1	1	1	1	1
17177-28031	Gasket, Intake Manifold to Head	1	1	1	1	1
17177-28040		1	-	-	-	-
17451-28070	Gasket, Exhaust Pipe	-	-	1	1	1
90917-06090		1	1	-	-	-

## 2AZ-FE Engine Oil Consumption

### Parts Information (Continued)

#### Kit Contents (Continued)

MODEL		Camry	Camry HV	Corolla	Matrix	RAV4
KIT PART NUMBER		04004-11228	04004-11428	04004-11628	04004-11728	04004-11828
PART NUMBER	PART NAME	QUANTITY (per Kit)				
94185-60800	Bolt (Front Exhaust Pipe No. 1 Support Bracket)	2	2	-	-	-
90917-06078	Gasket, Exhaust Pipe, Center	-	-	1	1	-
17451-31012		-	-	-	-	1
90917-06076		1	1	-	-	-
90177-22001	Nut (for Front Axle Shaft)	2	2	2	2	2
90119-10461	Bolt (for Drive Shaft Bearing Bracket Setting No. 1)	1	1	1	1	1
90901-19060	Bolt (for Drive Shaft Bearing Bracket Setting No. 1)	-	-	-	1	-
90311-38098	Seal, Oil (for Timing Chain Case)	1	1	1	1	1
90311-89010	Seal, Engine Rear Oil	1	1	1	1	1
90430-12031	Gasket (for Oil Pan Drain Plug)	1	1	1	1	1
90430-18008	Gasket, Drain Plug, etc.	2	3	2	2	1
90468-04193	Clip (Transmission Control Cable)	-	1	-	-	-
90468-14016		2	-	2	2	1
90520-22025	Ring, Hole Snap (for Piston Pin)	8	8	8	8	8
90520-38015	Ring, Hole Snap (for Front Drive Shaft RH)	1	1	1	1	2
90520-33008	Ring, Hole Snap (for Front Drive Shaft RH)	-	-	-	-	1
90521-33002	Ring, Hole Snap (for Front Drive Shaft LH)	1	1	1	1	1
95381-03020	Pin, Cotter (Tie Rod)	-	-	2	2	-
95381-03025	Pin, Cotter (Tie Rod)	2	2	-	-	2
96721-19010	Ring, O (for Oil Level Gage Guide)	1	1	1	1	1
96761-24020	Ring, O (for Cylinder Block to Crankcase Stiffener)	1	1	1	1	1
G1917-32010	Ring, O (for Camshaft Timing Oil Control Valve)	1	1	1	1	1

## 2AZ-FE Engine Oil Consumption

### Required Tools & Equipment

TOOLS & MATERIAL	PART NUMBER	QUANTITY	
Three Bond 1324 or Equivalent	—	As Needed	
FIPG Sealant or Equivalent	08826-00080	As Needed	
Super Long Life Coolant (SLLC)	00272-SLLC2	6.6 U.S. qts. (6.2 liters)	
ILSAC GF-4 Multi-grade SAE 0W-20 or 5W-20	—	Camry, Camry HV, RAV4, Solara	4.5 U.S. qts. (4.3 liters)
	—	Corolla, Matrix	4.0 U.S. qts. (3.8 liters)
Green Plastigage™	—	As Needed	
Cylinder Ridge Reamer	—	1	
Torque Yield Wrench	—	1	
Precision Straight Edge	—	1	
Piston Heater	—	1	
Piston Ring Compressor	—	1	
Torque Wrench	—	1	
Large Brass Punch	—	1	
Piston Ring Expander	—	1	
Thread Chaser	—	1	
Feeler Gauge	—	1	
Caliper Gauge	—	1	
Micrometer	—	1	
Vernier Caliper	—	1	
Engine Stand	—	1	

SPECIAL SERVICE TOOLS (SST)	PART NUMBER	QTY
Gasket Seal Cutter	<a href="#">09032-00100</a>	1

**NOTE**

Additional SSTs may be ordered by calling 1-800-933-8335.

## 2AZ-FE Engine Oil Consumption

---

### Repair Procedure

**NOTE**

Verify that Service Bulletin No. [T-SB-0158-14](#), "2AZ-FE Engine Oil Consumption Inspection Procedure," has been performed **BEFORE** continuing with this bulletin.

#### Replace the piston and piston ring set.

1. Remove the engine assembly and place on an engine stand.

Refer to the Technical Information System (TIS), applicable model and model year Repair Manual:

- [2007 / 2008 / 2009](#) Camry:  
*Engine/Hybrid System – Engine Mechanical – "2AZ-FE Engine Mechanical: Engine Assembly: Removal"*
- [2007 \(to 10/06\) / 2007 \(10/06 & later\) / 2008 / 2009 / 2010 / 2011](#) Camry HV:  
*Engine/Hybrid System – Engine Mechanical – "2AZ-FXE Engine Mechanical: Engine Assembly: Removal"*
- 2009 [Corolla / Matrix](#):  
*Engine/Hybrid System – Engine Mechanical – "2AZ-FE Engine Mechanical: Engine Assembly: Removal"*
- [2006 / 2007 / 2008](#) RAV4:  
*Engine/Hybrid System – Engine Mechanical – "2AZ-FE Engine Mechanical: Engine Assembly: Removal"*
- [2007 / 2008](#) Solara:  
*Engine/Hybrid System – Engine Mechanical – "2AZ-FE Engine Mechanical: Engine Assembly: Removal"*

2. Remove the cylinder head assembly.

Refer to TIS, applicable model and model year Repair Manual:

- [2007 / 2008 / 2009](#) Camry:  
*Engine/Hybrid System – Engine Mechanical – "2AZ-FE Engine Mechanical: Cylinder Head: Removal"*
- [2007 \(to 10/06\) / 2007 \(10/06 & later\) / 2008 / 2009 / 2010 / 2011](#) Camry HV:  
*Engine/Hybrid System – Engine Mechanical – "2AZ-FXE Engine Mechanical: Cylinder Head: Removal"*
- 2009 [Corolla / Matrix](#):  
*Engine/Hybrid System – Engine Mechanical – "2AZ-FE Engine Mechanical: Cylinder Head Gasket: Removal"*

## 2AZ-FE Engine Oil Consumption

---

### Repair Procedure (Continued)

- [2006](#) / [2007](#) / [2008](#) RAV4:  
*Engine/Hybrid System – Engine Mechanical – “2AZ-FE Engine Mechanical: Cylinder Head: Removal”*
- [2007](#) / [2008](#) Solara:  
*Engine/Hybrid System – Engine Mechanical – “2AZ-FE Engine Mechanical: Engine Unit: Disassembly”*

3. Remove the pistons from the connecting rods.

A. Remove the oil pan drain plug and gasket.

**Figure 1.**

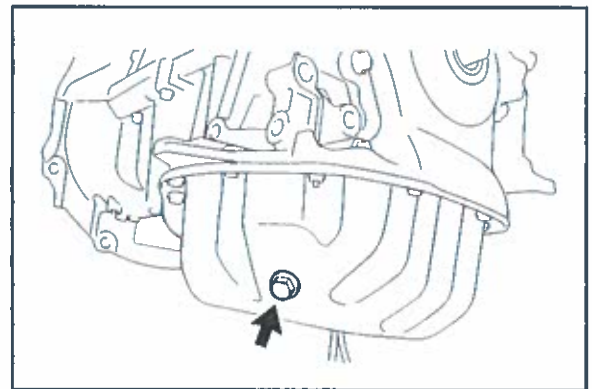

B. Remove the oil pan sub-assembly.

(1) Remove the 12 bolts and 2 nuts.

**Figure 2.**

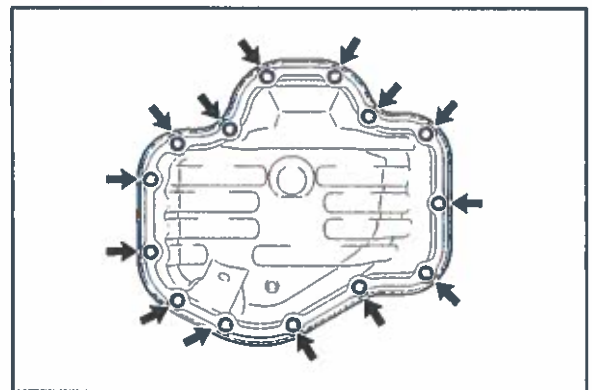



## 2AZ-FE Engine Oil Consumption

### Repair Procedure (Continued)

- (2) Insert the blade of the Gasket Seal Cutter between the crankcase and oil pan. Cut through the sealer and remove the oil pan.

SST: 09032-00100

**NOTICE**

Be careful NOT to damage the contact surfaces of the crankcase, chain cover, and oil pan.

Figure 3.

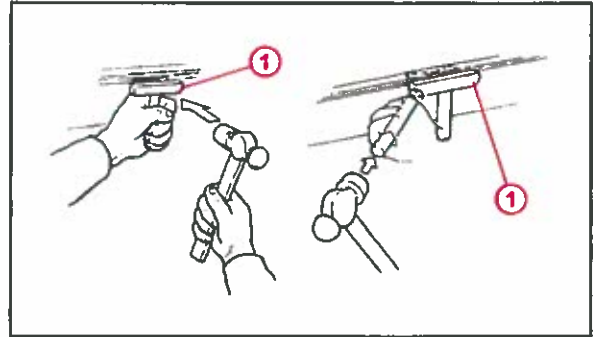

1 Gasket Seal Cutter

C. Remove the engine rear oil seal.

- (1) Using a knife, cut off the oil seal lip.
- (2) Using a screwdriver (with a taped tip), pry out the oil seal.

**NOTICE**

After removing the oil seal, check the crankshaft for damage. If the crankshaft is damaged, smooth the surface with 400-grit sandpaper.

Figure 4.

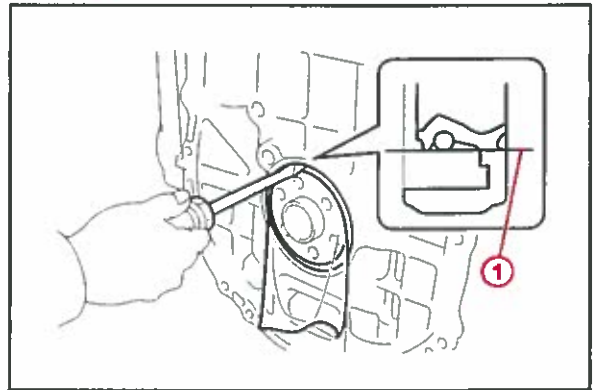

1 Cut Position

D. Remove the stiffening crankcase assembly.

**NOTICE**

Remove the stiffening crankcase as a unit. Do NOT separate the halves of the assembly, exposing the balance shaft bearings.

## 2AZ-FE Engine Oil Consumption

### Repair Procedure (Continued)

- (1) Uniformly loosen and remove the 11 bolts in the sequence shown in the illustration.

**Figure 5.**

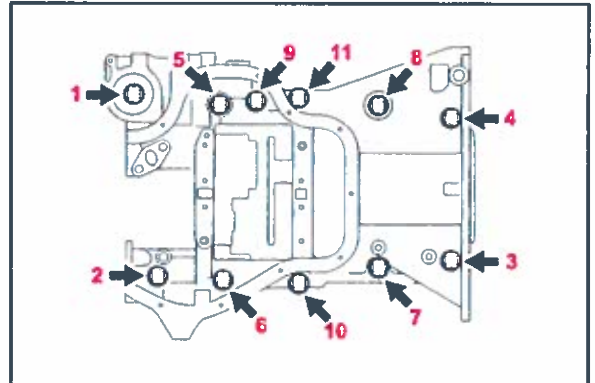

- (2) Using a screwdriver (with a taped tip), remove the crankcase by prying between the crankcase and cylinder block.

**Figure 6.**

**NOTICE**  
 Be careful NOT to damage the contact surfaces of the crankcase and cylinder block.

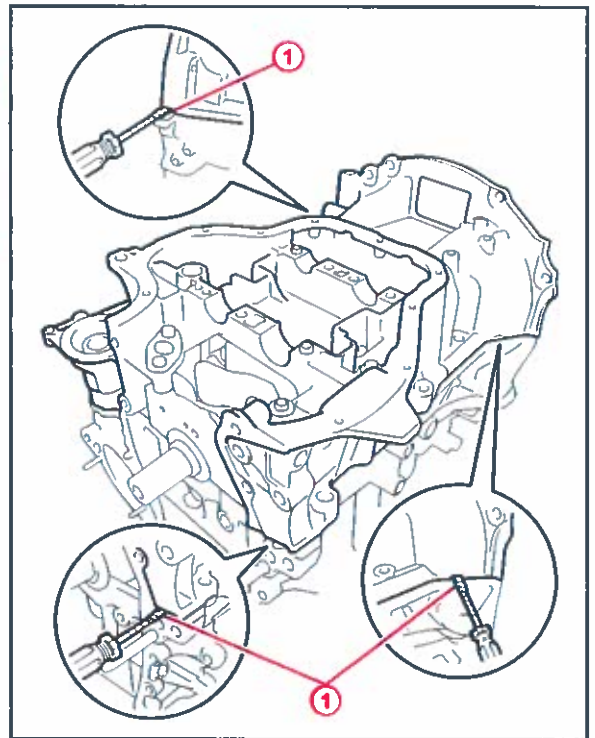

**1** Protective Tape

## 2AZ-FE Engine Oil Consumption

### Repair Procedure (Continued)

- (3) Remove the O-ring from the cylinder block.

**Figure 7.**

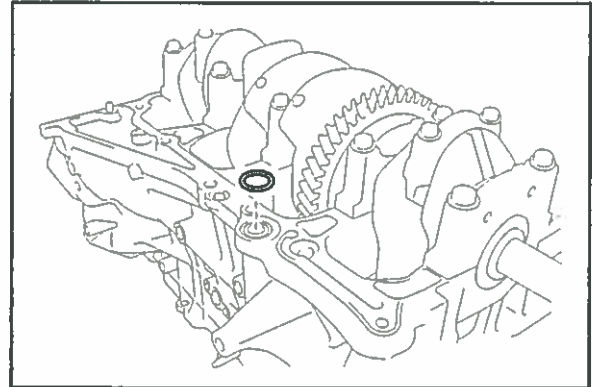

### E. Remove the piston sub-assemblies with connecting rod.

- (1) Using a ridge reamer, remove all the carbon from the top of the cylinder.

**Figure 8.**

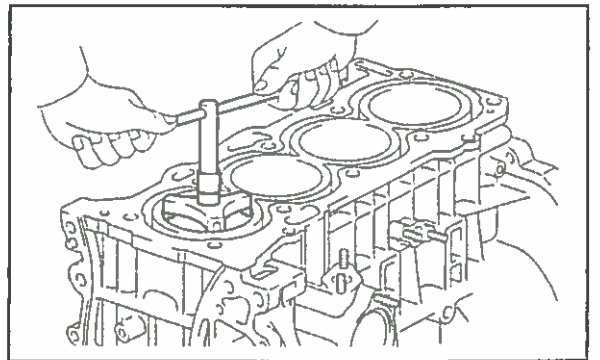

- (2) Check that the matchmarks on the connecting rod and cap are aligned to ensure correct reassembly.

**Figure 9.**

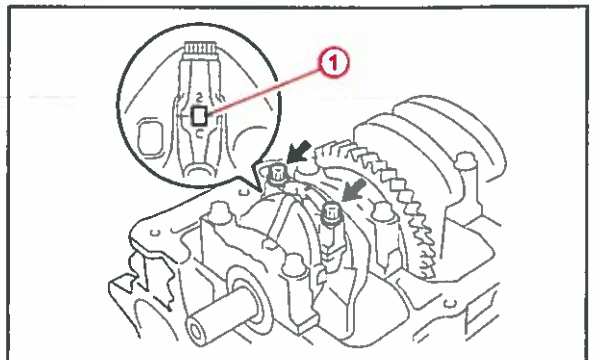

**HINT**

The matchmarks on the connecting rods and caps are provided for ensuring correct reassembly.

**1** Matchmark

## 2AZ-FE Engine Oil Consumption

### Repair Procedure (Continued)

- (3) Using a 12 mm socket wrench, uniformly loosen the 2 bolts.

**Figure 10.**

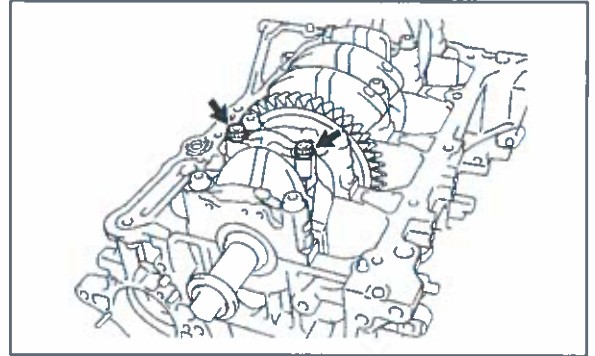

- (4) Using the 2 removed connecting rod cap bolts, remove the connecting rod cap and lower bearing by moving the connecting rod cap right and left.

**HINT**

Keep the lower bearing inserted in the connecting rod cap.

- (5) Inspect the connecting rod oil clearance.
1. Clean the crank pin and bearing.
  2. Check the crank pin and bearing for pitting and scratches.
  3. Lay a strip of Plastigage™ on the crank pin.

**Figure 11.**

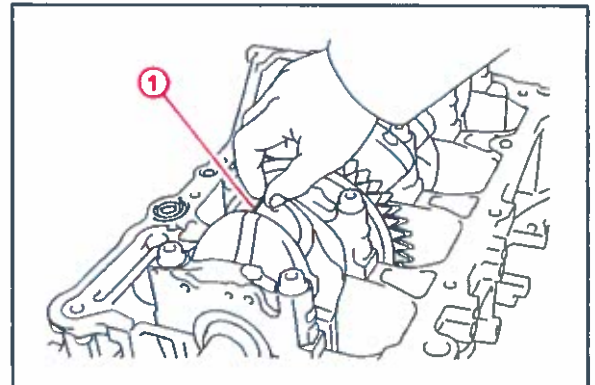

**1** Plastigage™

## 2AZ-FE Engine Oil Consumption

### Repair Procedure (Continued)

4. Check that the front mark of the connecting rod cap is facing forward.

**Figure 12.**

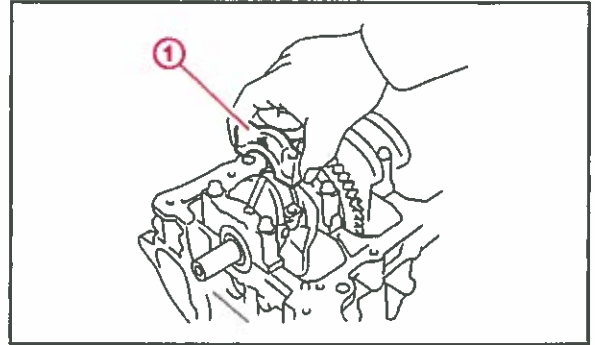

<b>1</b>	<b>Front Mark</b>
----------	-------------------

5. Install and alternately tighten the bolts of the connecting rod cap in several steps.

**Figure 13.**

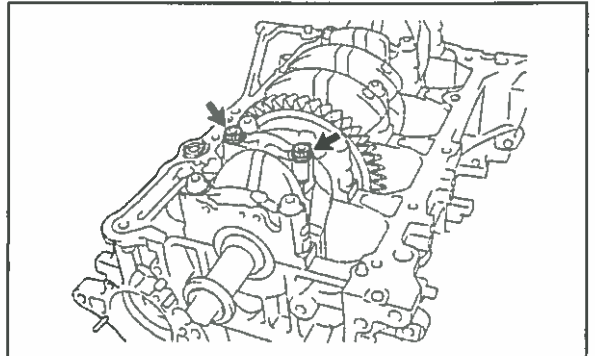

**Torque: 25 N\*m (250 kgf\*cm, 18 ft\*lbf)**

**NOTE**

The connecting cap bolts should be tightened in 2 progressive steps.

## 2AZ-FE Engine Oil Consumption

### Repair Procedure (Continued)

6. Mark the front of the connecting rod cap bolts with paint.

Retighten the cap bolts by 90° as shown in the illustration.

**Figure 14.**

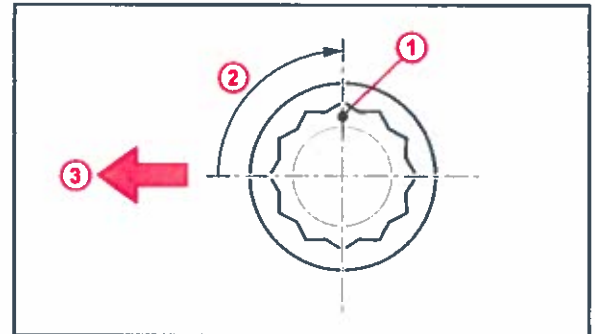

<b>1</b>	Paint Mark
<b>2</b>	90°
<b>3</b>	Engine Front

7. Remove the 2 bolts and connecting rod cap.

8. Measure the Plastigage™ at its widest point.

**Standard Oil Clearance: 0.024 to 0.048 mm (0.0009 to 0.0019 in.)**

**Maximum Oil Clearance: 0.08 mm (0.0032 in.)**

If the oil clearance is greater than the maximum, replace the connecting rod bearings. If necessary, inspect the crankshaft.

**NOTE**

**Completely remove the Plastigage™ after the measurement.**

## 2AZ-FE Engine Oil Consumption

### Repair Procedure (Continued)

#### HINT

If replacing a bearing, replace it with one that has the same number as its respective connecting rod cap. Each bearing's standard thickness is indicated by a 1, 2, or 3 mark on its surface.

#### Standard Connecting Rod Large End Bore Diameter:

MARK	SPECIFIED CONDITION
Mark 1	51.000 to 51.007 mm (2.0079 to 2.0082 in.)
Mark 2	51.008 to 51.013 mm (2.0082 to 2.0084 in.)
Mark 3	51.014 to 51.020 mm (2.0084 to 2.0087 in.)

#### Standard Connecting Rod Bearing Thickness:

MARK	SPECIFIED CONDITION
Mark 1	1.485 to 1.488 mm (0.0585 to 0.0586 in.)
Mark 2	1.489 to 1.491 mm (0.0586 to 0.0587 in.)
Mark 3	1.492 to 1.494 mm (0.0587 to 0.0588 in.)

#### Standard Crankshaft Pin Diameter:

MARK	SPECIFIED CONDITION
Mark 1	47.990 to 48.000 (1.8894 to 1.8898 in.)
Mark 2	
Mark 3	

Figure 15.

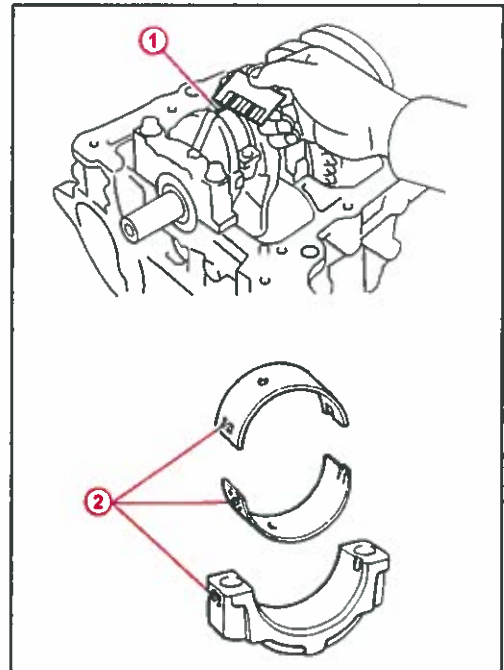

1	Plastigage™
2	1, 2, or 3 Mark

## 2AZ-FE Engine Oil Consumption

### Repair Procedure (Continued)

- (6) Push the piston, connecting rod assembly, and upper bearing through the top of the cylinder block.

**HINT**

- Keep the bearing, connecting rod, and cap together.
- Arrange the piston and connecting rod assemblies in the correct order.

- (7) Repeat for the other 3 piston/connecting rod assemblies.

- F. Remove the connecting rod bearings.

**HINT**

Arrange the removed parts in the correct order.

- G. Inspect the cylinder bore for abnormal damage.

Visually check the cylinder bore for the presence of crosshatch.

- If the cylinder bore has visible crosshatch, the cylinder block is OK to re-use.
- Confirm that only light vertical marks are present, if any.

**NOTE**

- It is normal for an in-service block to have light markings present from carbon and should NOT be interpreted as excessive cylinder wall scratches.
- ONLY replace the short block if multiple, severe scratches are present.
- Do NOT hone the cylinder walls.

- H. Using a screwdriver, pry out the 2 piston pin hole snap rings.

**HINT**

If necessary, submit the following specialized and precision operations to a local engine machining shop.

Figure 16.

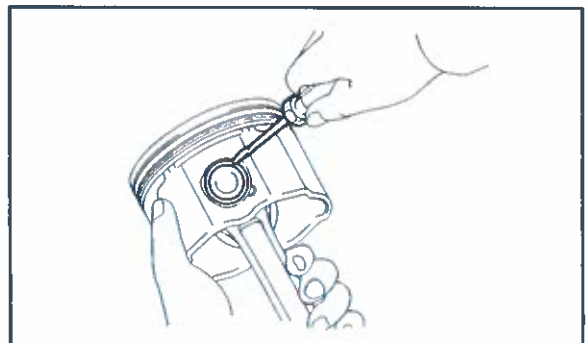



## 2AZ-FE Engine Oil Consumption

### Repair Procedure (Continued)

- I. Remove the piston.
  - (1) Gradually heat the piston to approximately 176° to 194°F (80° to 90°C).

Figure 17.

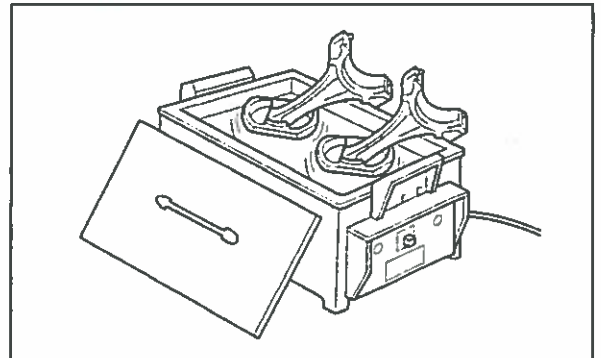

- (2) Using a plastic hammer and brass bar, lightly tap out the piston pin and remove the connecting rod.

Figure 18.

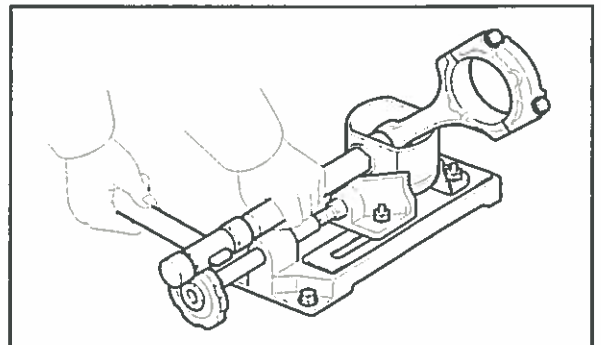

**NOTE**

- The piston and pin are a matched set.
- Arrange the pistons, pins, rings, connecting rods, and bearings in the correct order.

For additional information, refer to TIS, applicable model and model year Repair Manual:

- [2007](#) / [2008](#) / [2009](#) Camry:  
*Engine/Hybrid System – Engine Mechanical – “2AZ-FE Engine Mechanical: Engine Unit: Disassembly”*
- [2007 \(to 10/06\)](#) / [2007 \(10/06 & later\)](#) / [2008](#) / [2009](#) / [2010](#) / [2011](#) Camry HV:  
*Engine/Hybrid System – Engine Mechanical – “2AZ-FXE Engine Mechanical: Engine Unit: Disassembly”*
- 2009 [Corolla](#) / [Matrix](#):  
*Engine/Hybrid System – Engine Mechanical – “2AZ-FE Engine Mechanical: Engine Unit: Disassembly”*
- 2009 [Corolla](#) / [Matrix](#):  
*Engine/Hybrid System – Engine Mechanical – “2AZ-FE Engine Mechanical: Cylinder Block: Disassembly”*

## 2AZ-FE Engine Oil Consumption

### Repair Procedure (Continued)

- [2006](#) / [2007](#) / [2008](#) RAV4:  
*Engine/Hybrid System – Engine Mechanical – “2AZ-FE Engine Mechanical: Engine Unit: Disassembly”*
  - [2007](#) / [2008](#) Solara:  
*Engine/Hybrid System – Engine Mechanical – “2AZ-FE Engine Mechanical: Engine Unit: Disassembly”*
4. Measure and inspect the piston pin, connecting rod, and bearings to determine replacement part numbers and if parts are suitable for re-use.

**NOTE**

The following steps are required to determine the correct replacement part numbers.

**HINT**

If necessary, sublet the following specialized and precision operations to a local engine machining shop.

- A. Inspect the original piston pin oil clearance to determine the correct replacement piston part number below.

- (1) Using a caliper gauge, measure the piston pin bore diameter.

**Standard Piston Pin Bore Diameter:**  
22.001 to 22.010 mm (0.8662 to 0.8665 in.)

**Figure 19.**



PART NUMBER		SPECIFIED CONDITION
CAMRY, COROLLA, MATRIX, RAV4, SOLARA	CAMRY HV	
04004-79128-A0	13211-28150-A0	22.001 to 22.004 mm (0.8662 to 0.8663 in.)
04004-79128-B0	13211-28150-B0	22.005 to 22.007 mm (0.8663 to 0.8664 in.)
04004-79128-C0	13211-28150-C0	22.008 to 22.010 mm (0.8664 to 0.8665 in.)

## 2AZ-FE Engine Oil Consumption

### Repair Procedure (Continued)

- (2) Using a micrometer, measure the piston pin diameter.

**Standard Piston Pin Diameter: 21.997 to 22.006 mm (0.8660 to 0.8664 in.)**

If the diameter is NOT as specified, replace the piston pin.

**Figure 20.**

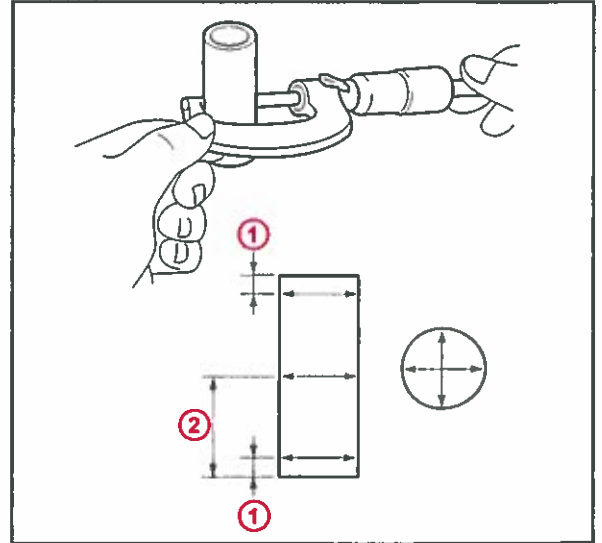

<b>1</b>	5 mm (0.20 in.)
<b>2</b>	30 mm (1.18 in.)

PART NUMBER	SPECIFIED CONDITION
13251-0H030-A0	21.997 to 22.000 mm (0.8660 to 0.8661 in.)
13251-0H030-B0	22.001 to 22.003 mm (0.8662 to 0.8663 in.)
13251-0H030-C0	22.004 to 22.006 mm (0.8663 to 0.8664 in.)

## 2AZ-FE Engine Oil Consumption

### Repair Procedure (Continued)

- (3) Using a caliper gauge, measure the connecting rod small end bore diameter.  
**Standard Connecting Rod Small End Bore Diameter:**  
 22.005 to 22.014 mm (0.8663 to 0.8667 in.)

If the diameter is NOT as specified, replace the connecting rod.

Figure 21.

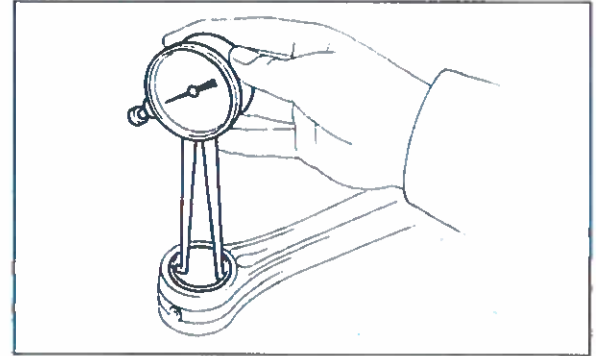

PART NUMBER		SPECIFIED CONDITION
13201-09790-A0	13201-29686-A0	22.005 to 22.008 mm (0.8663 to 0.8665 in.)
13201-09790-B0	13201-29686-B0	22.009 to 22.011 mm (0.8665 to 0.8666 in.)
13201-09790-C0	13201-29686-C0	22.012 to 22.014 mm (0.8666 to 0.8667 in.)

### B. Inspect the connecting rod bolt.

Using vernier calipers, measure the tension portion diameter of the bolt.

**Standard Diameter: 7.2 to 7.3 mm**  
 (0.283 to 0.287 in.)

**Minimum Diameter: 7.0 mm (0.276 in.)**

If the diameter is less than the minimum, replace the connecting rod bolt.

Figure 22.

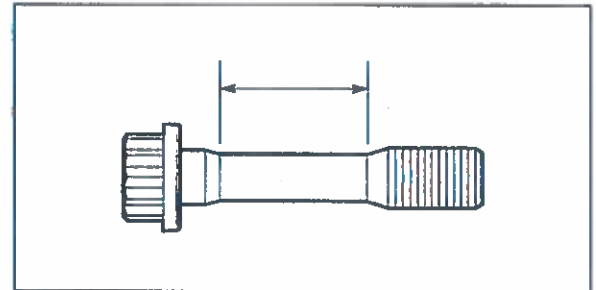

For additional information, refer to TIS, applicable model and model year Repair Manual:

- [2007](#) / [2008](#) / [2009](#) Camry:  
*Engine/Hybrid System – Engine Mechanical – “2AZ-FE Engine Mechanical: Engine Unit: Inspection”*
- [2007 \(to 10/06\)](#) / [2007 \(10/06 & later\)](#) / [2008](#) / [2009](#) / [2010](#) / [2011](#) Camry HV:  
*Engine/Hybrid System – Engine Mechanical – “2AZ-FXE Engine Mechanical: Engine Unit: Inspection”*
- 2009 [Corolla](#) / [Matrix](#):  
*Engine/Hybrid System – Engine Mechanical – “2AZ-FE Engine Mechanical: Cylinder Block: Inspection”*

## 2AZ-FE Engine Oil Consumption

---

### Repair Procedure (Continued)

- [2006](#) / [2007](#) / [2008](#) RAV4:  
*Engine/Hybrid System – Engine Mechanical – “2AZ-FE Engine Mechanical: Engine Unit: Inspection”*
- [2007](#) / [2008](#) Solara:  
*Engine/Hybrid System – Engine Mechanical – “2AZ-FE Engine Mechanical: Engine Unit: Inspection”*

5. Install the new pistons and rings and reassemble the engine in reverse order of disassembly.

For additional information, refer to TIS, applicable model and model year Repair Manual:

- [2007](#) / [2008](#) / [2009](#) Camry:  
*Engine/Hybrid System – Engine Mechanical – “2AZ-FE Engine Mechanical: Engine Unit: Reassembly”*
- [2007](#) / [2008](#) / [2009](#) Camry:  
*Engine/Hybrid System – Engine Mechanical – “2AZ-FE Engine Mechanical: Cylinder Head: Installation”*
- [2007 \(to 10/06\)](#) / [2007 \(10/06 & later\)](#) / [2008](#) / [2009](#) / [2010](#) / [2011](#) Camry HV:  
*Engine/Hybrid System – Engine Mechanical – “2AZ-FXE Engine Mechanical: Engine Unit: Reassembly”*
- [2007 \(to 10/06\)](#) / [2007 \(10/06 & later\)](#) / [2008](#) / [2009](#) / [2010](#) / [2011](#) Camry HV:  
*Engine/Hybrid System – Engine Mechanical – “2AZ-FXE Engine Mechanical: Cylinder Head: Installation”*
- 2009 [Corolla](#) / [Matrix](#)  
*Engine/Hybrid System – Engine Mechanical – “2AZ-FE Engine Mechanical: Cylinder Block: Reassembly”*
- 2009 [Corolla](#) / [Matrix](#)  
*Engine/Hybrid System – Engine Mechanical – “2AZ-FE Engine Mechanical: Engine Unit: Reassembly”*
- 2009 [Corolla](#) / [Matrix](#)  
*Engine/Hybrid System – Engine Mechanical – “2AZ-FE Engine Mechanical: Cylinder Head Gasket: Installation”*
- [2006](#) / [2007](#) / [2008](#) RAV4:  
*Engine/Hybrid System – Engine Mechanical – “2AZ-FE Engine Mechanical: Engine Unit: Reassembly”*
- [2006](#) / [2007](#) / [2008](#) RAV4:  
*Engine/Hybrid System – Engine Mechanical – “2AZ-FE Engine Mechanical: Cylinder Head: Installation”*
- [2007](#) / [2008](#) Solara:  
*Engine/Hybrid System – Engine Mechanical – “2AZ-FE Engine Mechanical: Engine Unit: Reassembly”*

## 2AZ-FE Engine Oil Consumption

---

### Repair Procedure (Continued)

6. Install the engine assembly.

Refer to TIS, applicable model and model year Repair Manual:

- [2007 / 2008 / 2009](#) Camry:  
*Engine/Hybrid System – Engine Mechanical – “2AZ-FE Engine Mechanical: Engine Assembly: Installation”*
- [2007 \(to 10/06\) / 2007 \(10/06 & later\) / 2008 / 2009 / 2010 / 2011](#) Camry HV:  
*Engine/Hybrid System – Engine Mechanical – “2AZ-FXE Engine Mechanical: Engine Assembly: Installation”*
- 2009 [Corolla](#) / [Matrix](#):  
*Engine/Hybrid System – Engine Mechanical – “2AZ-FE Engine Mechanical: Engine Assembly: Installation”*
- [2006 / 2007 / 2008](#) RAV4:  
*Engine/Hybrid System – Engine Mechanical – “2AZ-FE Engine Mechanical: Engine Assembly: Installation”*
- [2007 / 2008](#) Solara:  
*Engine/Hybrid System – Engine Mechanical – “2AZ-FE Engine Mechanical: Engine Assembly: Installation”*

7. Test drive the vehicle to verify normal operation.