



Service Bulletin

PRELIMINARY INFORMATION

Subject: Rough Running - Idle Surge - CEL On Or CMP Actuator Codes After Installation Of Reman HVV6

Models: 2009-2011 Buick Lucerne
2006 Buick Rendezvous
2005-2006 Buick Terraza
2007-2011 Chevrolet Impala
2007-2010 Chevrolet Malibu
2006-2007 Chevrolet Monte Carlo
2005-2006 Chevrolet Uplander
2005-2008 Pontiac G6
2005-2006 Pontiac Montana SV6
2007-2008 Saturn Aura
2005-2006 Saturn Relay
2007 Saturn Vue
With 3.5L Engine (RPO LZE or LZ4)
or 3.9L Engine (RPO LZ8, LZ9, LZG or LGD)

This PI was superseded to update model list. Please discard PIP5064B.

The following diagnosis might be helpful if the vehicle exhibits the symptom(s) described in this PI.

Condition/Concern

A technician may encounter any of the following concerns after installing a Reman HVV6 engine, Rough running, idle surge, misfire on one or both banks of the engine with a P0300, CEL or CMP actuator DTC P0011 and / or P0016.

Recommendation/Instructions

If you encounter the above concern, record the actual engine oil pressure.

Oil Pressure for 3.5L engines = 30–45 PSI @ 1850 RPM

Oil Pressure for 3.9L engines = 30–45 PSI @ 1850 RPM and 26 PSI @ Idle with Warm Engine

If oil pressure is within the specifications above, perform all testing listed in PIP4345A including a visual inspection of the camshaft position actuator filter (see picture below) and repair or replace as necessary.

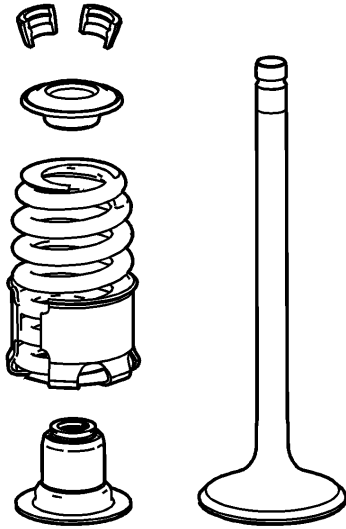

If single bank misfires are found, then remove the valve cover of the affected bank and check the valve springs for missing harmonic stabilizers (see picture below.) Replace the valve spring assemblies if the stabilizers are not present and retest for the misfires.

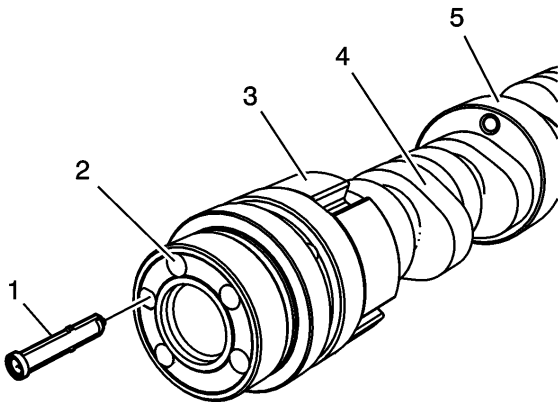

If the concern is not isolated, contact TAC for additional direction.

Notice: Record the engine build date and serial number from the engine. The HVV6 identification tag location is the same for all listed engines, at the pan rail, towards the middle of the block, on the left side.

Warranty Information

The correction for this concern may be one of several repairs described above. For vehicles repaired under warranty, please use the appropriate warranty labor operation and time, based on the actual cause and repair.

Please follow this diagnostic or repair process thoroughly and complete each step. If the condition exhibited is resolved without completing every step, the remaining steps do not need to be performed.

GM bulletins are intended for use by professional technicians, NOT a "do-it-yourselfer". They are written to inform these technicians of conditions that may occur on some vehicles, or to provide information that could assist in the proper service of a vehicle. Properly trained technicians have the equipment, tools, safety instructions, and know-how to do a job properly and safely. If a condition is described, DO NOT assume that the bulletin applies to your vehicle, or that your vehicle will have that condition. See your GM dealer for information on whether your vehicle may benefit from the information.



WE SUPPORT VOLUNTARY TECHNICIAN CERTIFICATION