

December 11, 2014

ATB 51811-01162 REV4 (1412)

Safety Recall: Front Passenger's Airbag Inflator Can Be Over-Pressurized

Supersedes 14-040, dated November 7, 2014, to revise the information highlighted in **yellow**

Replaces 14-041, *Safety Recall: Civic, CR-V, and Odyssey - Front Passenger's Airbag Inflator Can Be Over-Pressurized*

AFFECTED VEHICLES

Year	Model	Trim	VIN Range
2003	Accord	ALL	Check the iN VIN status for eligibility
2002-03	Civic	ALL	Check the iN VIN status for eligibility
2002-03	Civic GX	ALL	Check the iN VIN status for eligibility
2003	Civic Hybrid	ALL	Check the iN VIN status for eligibility
2002-03	CR-V	ALL	Check the iN VIN status for eligibility
2003	Element	ALL	Check the iN VIN status for eligibility
2002-03	Odyssey	ALL	Check the iN VIN status for eligibility
2003	Pilot	ALL	Check the iN VIN status for eligibility

REVISION SUMMARY

- Vehicles sold and/or registered in Alabama, Florida, Georgia, Hawaii, Louisiana, Mississippi, South Carolina, Texas, Puerto Rico, Guam, Saipan, American Samoa, and the U.S. Virgin Islands were superseded to Service Bulletin 14-070, *Safety Recall: Front Passenger's Airbag Inflator May Produce Excessive Pressure After Long-Term Exposure To High Absolute Humidity*.
- Information was added under **BACKGROUND, WARRANTY CLAIM INFORMATION, and REPAIR PROCEDURE.**

BACKGROUND

In certain vehicles, the passenger's (front) airbag inflator could produce excessive internal pressure during airbag deployment. If an affected airbag deploys, the increased internal pressure may cause the inflator casing to rupture. Metal fragments could be propelled upward toward the windshield, or downward toward the front passenger's foot well, possibly causing an injury to vehicle occupants.

NOTE: If the VIN status inquiry indicates that the vehicle is subject to any open safety recalls, including the driver's airbag inflator, make sure to also complete those recall repairs before returning the vehicle to the customer. If you are unable to complete any open recall, advise the customer of the recall status and when the recall could be completed.

CUSTOMER INFORMATION: The information in this bulletin is intended for use only by skilled technicians who have the proper tools, equipment, and training to correctly and safely maintain your vehicle. These procedures should not be attempted by "do-it-yourselfers," and you should not assume this bulletin applies to your vehicle, or that your vehicle has the condition described. To determine whether this information applies, contact an authorized Honda automobile dealer.

CUSTOMER NOTIFICATION

Owners of affected vehicles will be sent a notification of this campaign.

Do an iN VIN status inquiry to make sure the vehicle is shown as eligible.

Some vehicles affected by this campaign may be in your used vehicle inventory. These vehicles must be repaired before they are sold.

Should a dealership sell an unrepaired vehicle that subsequently causes an injury or damage because of the recalled item, the dealership will be solely responsible to the damaged party, and will be required to defend and indemnify American Honda for any resulting claims. To see if a vehicle in inventory is affected by this campaign, do a VIN status inquiry before selling it.

CORRECTIVE ACTION

Install a passenger's airbag inflator kit, then return the original undeployed inflator as directed.

PARTS INFORMATION

Part Name	Part Number	Quantity
Accord Passenger (Front) Airbag Inflator Kit	04785-SDA-307	1
Civic Passenger (Front) Airbag Inflator Kit (includes GX and Hybrid)	04785-S5A-307	1
CR-V Passenger (Front) Airbag Inflator Kit	04785-S9A-307	1
Element Passenger (Front) Airbag Inflator Kit	04785-SCV-307	1
2002 Odyssey Passenger (Front) Airbag Inflator Kit	04785-S0X-307	1
2003 Odyssey Passenger (Front) Airbag Inflator Kit	04785-S0X-306	1
Pilot Passenger (Front) Airbag Inflator Kit	04785-S9V-307	1

NOTE:

- The inflator kit box must be used to return the old inflator to its supplier, ideally within 48 hours of the repair. Be careful not to damage the inflator kit box.
- If the recalled, undeployed inflator is not returned, the warranty claim for that vehicle will be charged back to your dealership.
- Follow the shipping instructions supplied with the inflator kit. If you have any questions about shipping, call Warranty Parts Inspection (WPI) at **937-642-2737**.
- If you are a dealer in Alaska, Hawaii, Puerto Rico, Guam, Saipan, American Samoa, or the U.S. Virgin Islands call the WPI administrative office at **937-642-2737** for special instructions; do not use the documentation included in the airbag inflator kit.

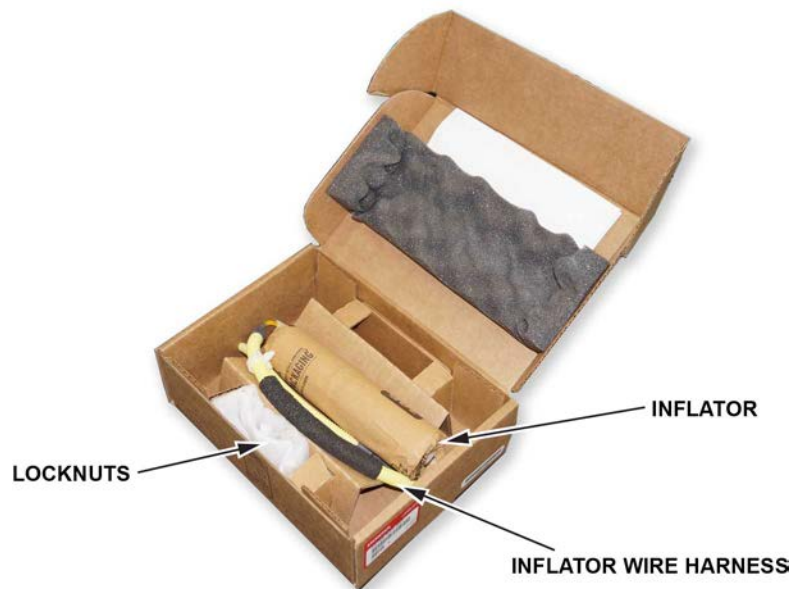

WARRANTY CLAIM INFORMATION

NOTE:

- Process claims as quickly as possible so that resources can be properly allocated.
- To avoid non-payment of warranty claims, the serial number on the box of the new airbag inflator must be entered in the Diagnostic Trouble Codes field on each warranty claim. For more information, refer to step 1 of REPAIR PROCEDURE.
- To avoid a warranty claim being charged back to your dealership, you must return the original undeployed inflator to its supplier. Follow the shipping instructions supplied with the inflator kit. If you have any questions about shipping, call Warranty Parts Inspection (WPI) at **937-642-2737**.

Year/Model	Operation Number	Description	Flat Rate Time	Defect Code	Symptom Code	Template ID	Failed Part Number
2003 Accord	7541A9	Replace the passenger's (front) airbag inflator.	0.7 hr	5JK00	JJ600	14-040A	06780-SDA-A80ZA
2002-03 Civic	7541A9		0.7 hr	5JK00	JJ700	14-040B	06780-S5A-A80ZA
2002-03 Civic GX	7541A9		0.7 hr	5JK00	JJ700	14-040B	06780-S5A-A80ZA
2003 Civic Hybrid	7541A9		0.7 hr	5JK00	JJ700	14-040B	06780-S5A-A80ZA
2002-03 CR-V	7541A9		0.7 hr	5JK00	JJ800	14-040C	06780-S9A-A80ZA
2003 Element	7541A9		0.8 hr	5JK00	JJ900	14-040D	06780-SCV-A80ZA
2002 Odyssey	7541A0		0.7 hr	5UK00	JK000	14-040G	06780-S0X-A10ZA
2003 Odyssey	7541A0		0.7 hr	5UK00	JK000	14-040E	06780-S0X-A10ZA
2003 Pilot	7541A0		0.8 hr	5UK00	JK100	14-040F	06780-S9V-A80ZA

Skill Level: Repair Technician

REPAIR PROCEDURE

NOTE:

- If the VIN status inquiry indicates that the vehicle is subject to any open safety recalls, including the driver's airbag inflator, make sure to also complete those recall repairs before returning the vehicle to the customer. If you are unable to complete any open recall, advise the customer of the recall status and when the recall could be completed.
 - Be careful not to damage any parts when replacing the inflator, and **follow the procedure exactly**.
 - The procedure shows the Civic/CR-V airbag. The brackets on the other vehicles are slightly different but the repair procedure is the same.
1. Write down the serial number located on the right side of the new inflator box. For the warranty claim to be paid, your warranty clerk must enter this serial number in the Diagnostic Trouble Codes field on the warranty claim.



SERIAL NUMBER

2. Remove the front passenger's airbag by referring to the applicable electronic service manual.
3. Place the airbag face-down on a clean shop towel as shown.

NOTE:

- The orientation of the airbag is critical because if the inflator is installed incorrectly, the harness will be too short when you reinstall the airbag.
- The brackets between the various models are similar but may differ from the example shown in the procedure.

ACCORD



ELEMENT



PILOT



Civic, CR-V



Odyssey

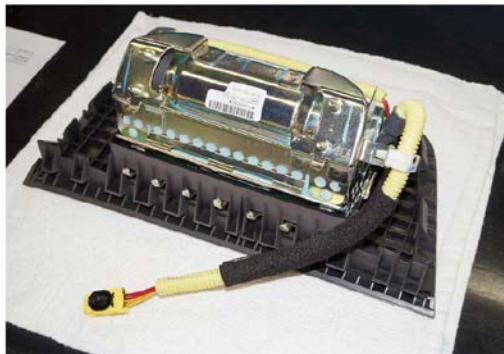

4. Visually inspect the airbag and the inflator for any unusual writing or markings.
- If there is nothing unusual about the airbag or the inflator, go to step 5.
 - If there are any unusual markings, like an incorrect label or a model year written in marker, the airbag and inflator may not be the correct airbag and/or inflator for the vehicle or it may be a counterfeit part. For more information about counterfeit airbags, you can refer to safercar.gov, enter keywords **MANAGING COUNTERFEIT**, and select **Recommended Dealer Guidance for Managing Counterfeit Air Bags** from the list. **If you suspect that the airbag or inflator is counterfeit, do not continue this procedure.** Contact your DPSM for assistance.

NON-STANDARD SAFETY LABEL

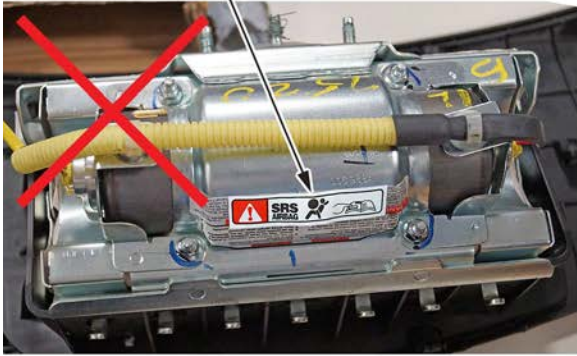

GREASE PENCIL OR PAINT MARKINGS

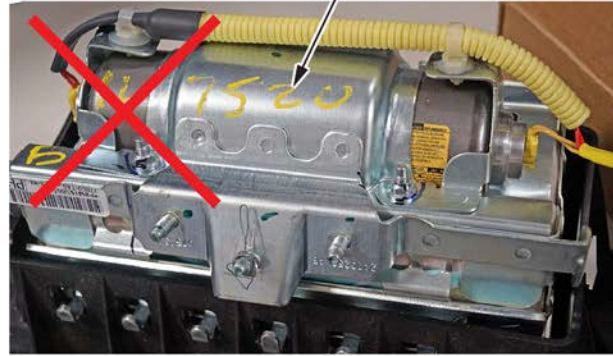

HAND ENGRAVING



NO LABELS ON INFLATOR



5. Remove the harness from both ends of the inflator bracket.

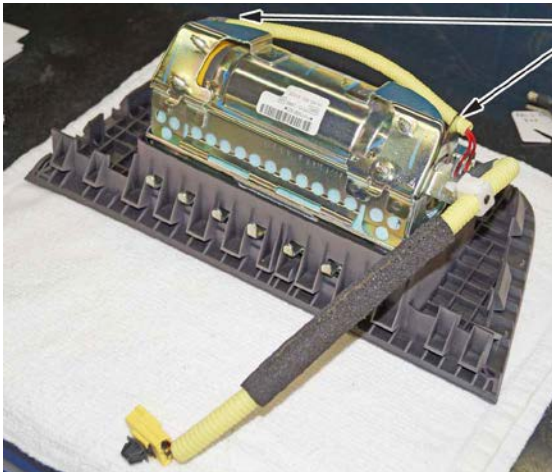

INFLATOR BRACKETS

6. Short the red wires.

NOTE: **You must cut and short the wires** as indicated to prevent any accidental deployment.

- Cut the red wires as shown.

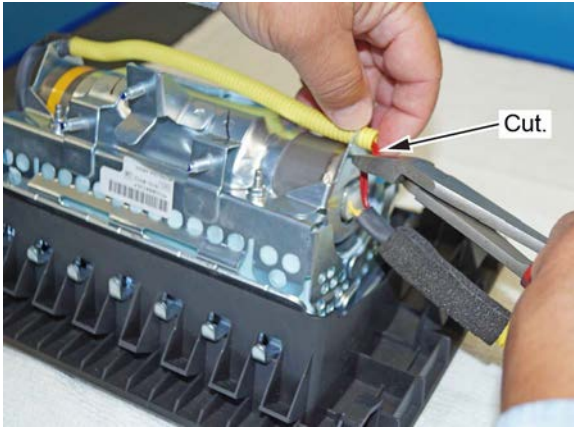

- Cut about 2 inches of the corrugated tube, then pull out the two red wires.

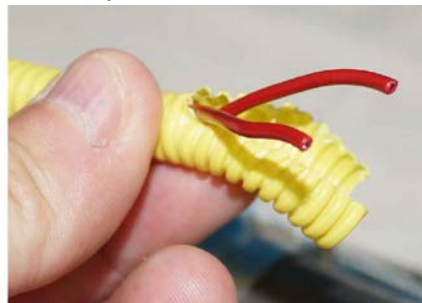
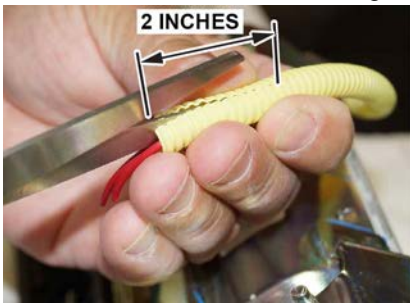

- Strip away about 1 inch of the wire insulation, then twist the wires together.

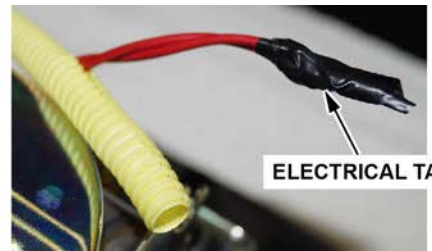
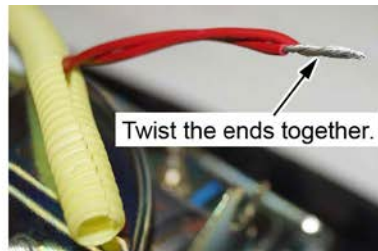

- Tape the twisted ends with electrical tape.

7. Cut off the connector and short the yellow wires.

You must cut and short the wires as indicated to prevent any accidental deployment.

- Cut all four wires to remove the connector.

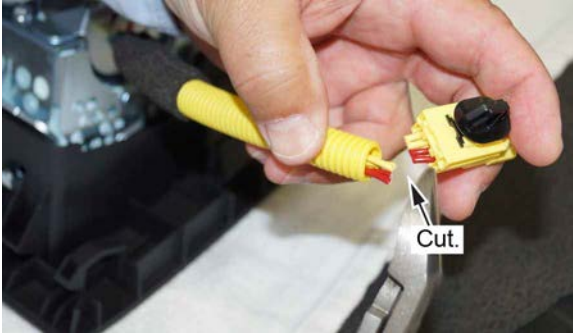

- Cut about 2 inches of the corrugated tube, then pull out the yellow wires.

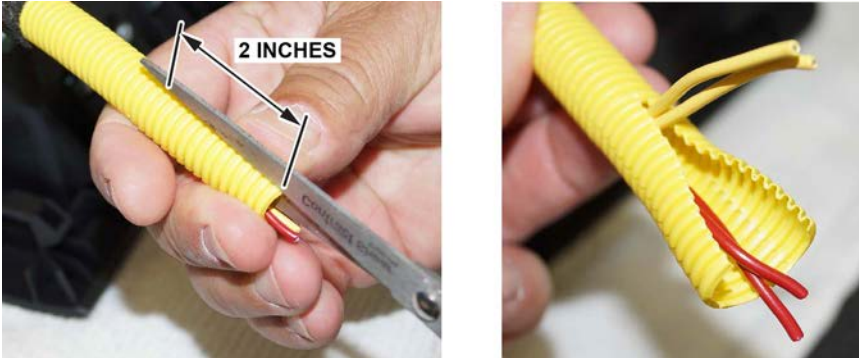

- Strip away about an inch of the wire insulation, then twist the wires together.

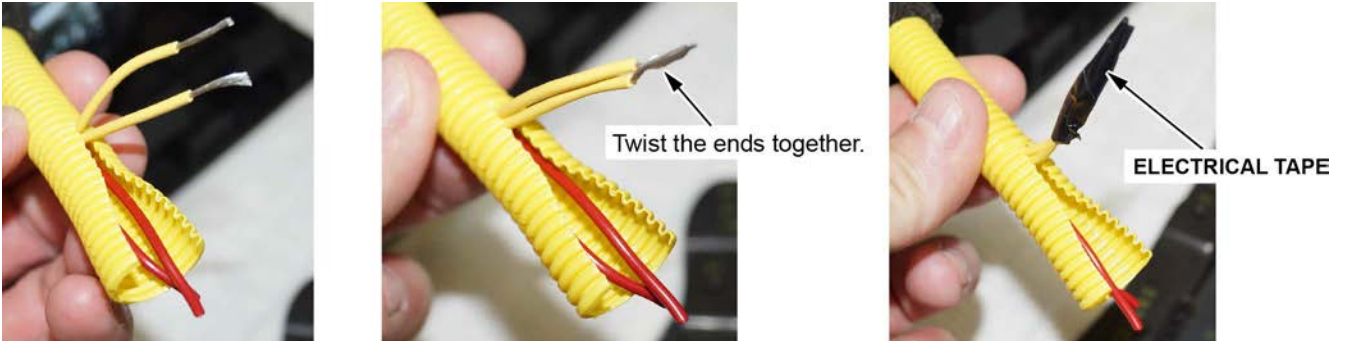

- Tape the twisted ends with electrical tape.

8. Remove the four inflator nuts.

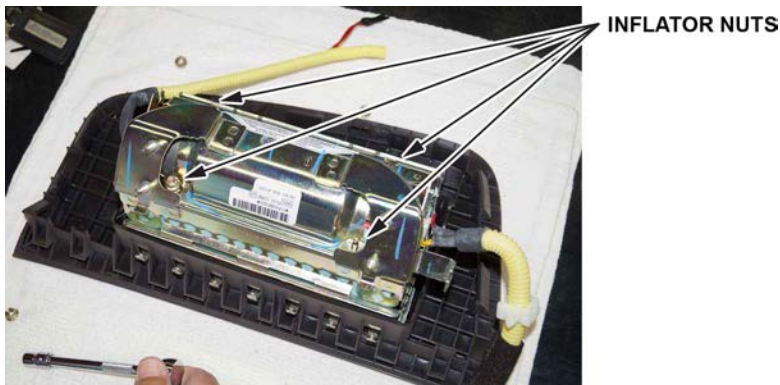

9. Remove the inflator bracket.

NOTE: You can only remove one of the brackets, as the other is welded to the airbag housing.

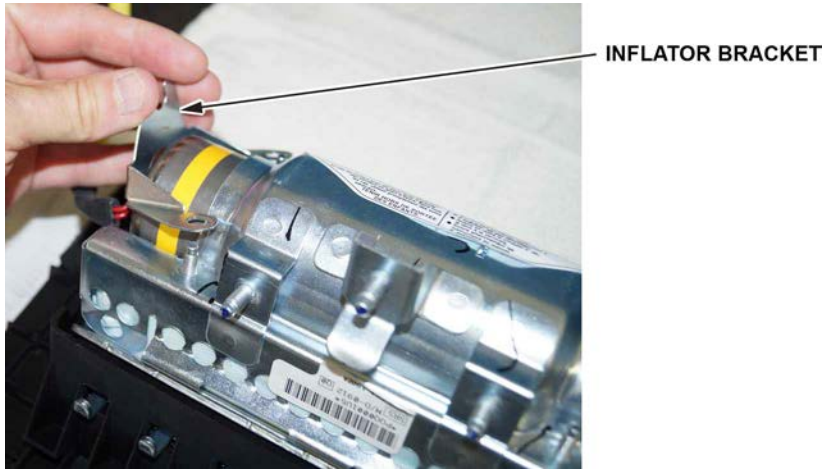

10. Remove the inflator by pushing it out.

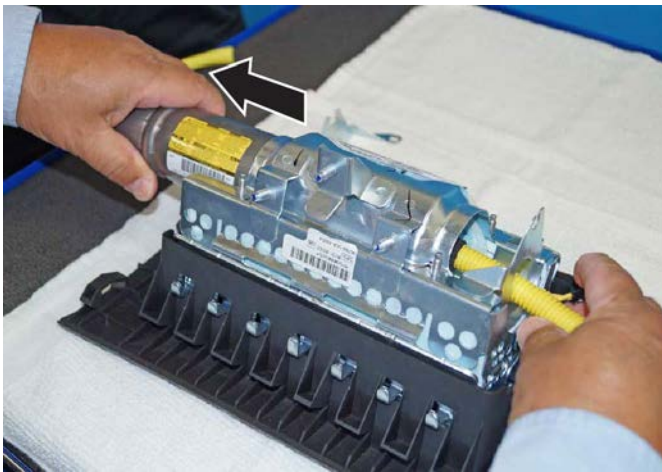

11. Install the new inflator.

- One connector looks like a “D” whereas the other connector is a circle. Make sure you insert the “D” connector into the airbag first.

NOTE: There is a yellow band marking on the circle side.

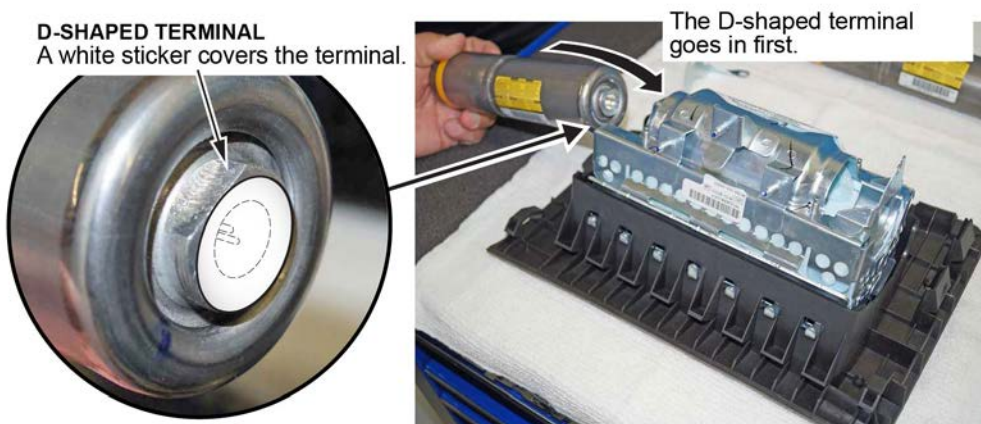

- Slide the inflator in until the “D” aligns with the tab on the inflator bracket. There should be no space or gap between the inflator and bracket.

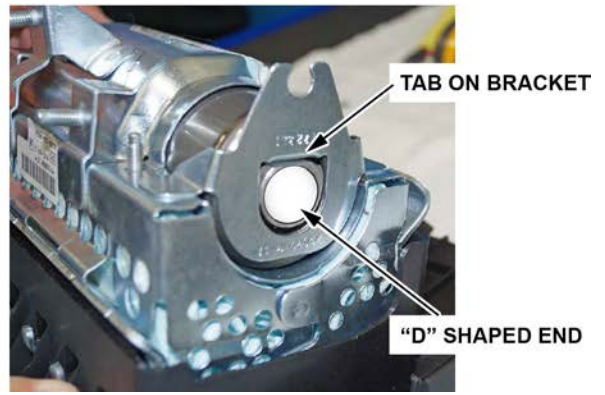

- Reinstall the inflator bracket. There should be no space or gap between the bracket and inflator.



- Install the new 5 mm locknuts and torque them in sequence to **3.9 N•m (34 lb-in)**.

Be sure there are no gaps between the inflator ends and the inflator brackets.

LOCK NUTS (4)
3.9 N•m (34 lb-in)

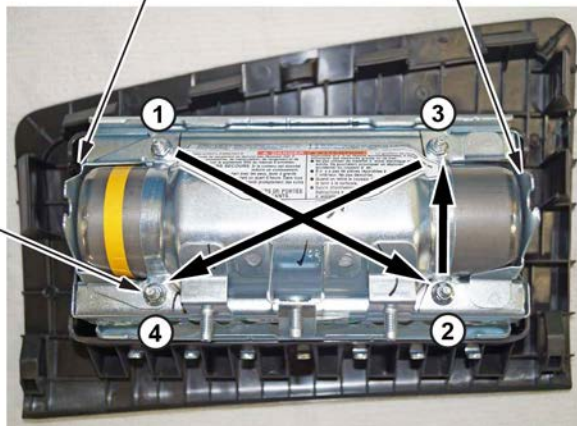

12. Remove the stickers covering the terminals on both sides of the new inflator.



13. Install the new inflator harness.

- Make sure the airbag and harness are aligned as shown.
NOTE: Make sure you have the orientation correct as shown below. If you connect the harness incorrectly, the harness cannot be removed and you will not be able to reinstall the airbag because the harness will be too short.



- Connect the two connectors. **Align the "T" shape in the inflator harness connector with the T-shaped inflator connector**, then press the connector into place.

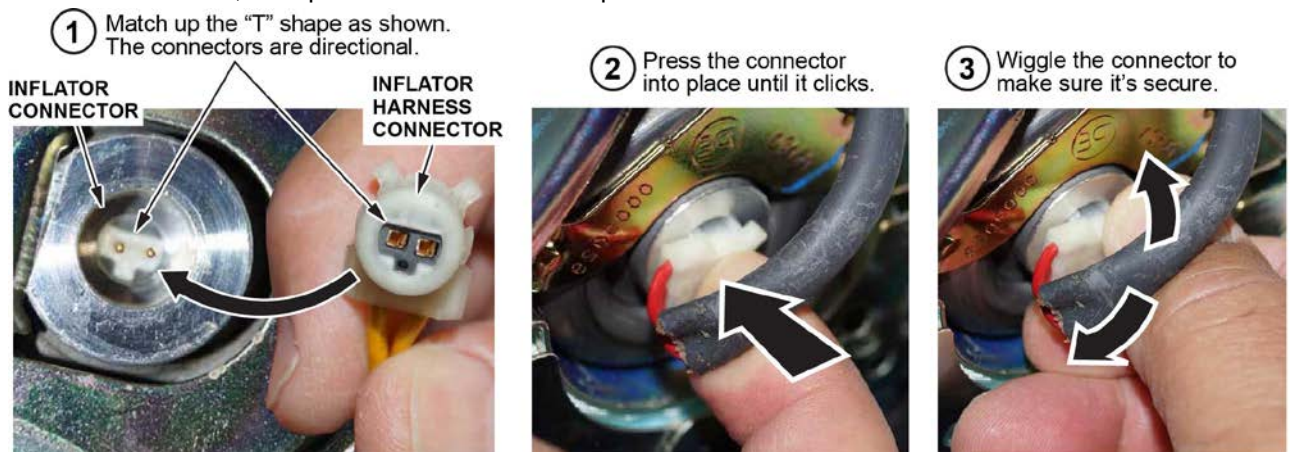

- After you hear each connector click, wiggle it to make sure it is secure.
NOTE: If the connector is not properly aligned, it will come out.

14. Connect the harness to the inflator brackets.

- Insert the side without the shrink-wrap tubing first. Insert the harness at the third “valley” in the corrugated tube.
- Insert the side of the harness with the shrink-wrap tubing into the inflator bracket. Make sure the harness is securely inserted and that it does not sag.

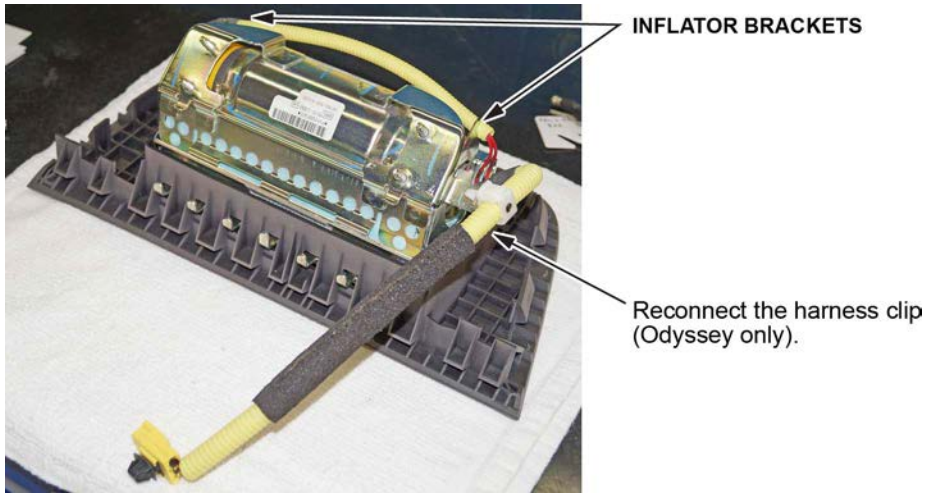

15. Reinstall the passenger's airbag into the vehicle and torque the new locknuts to **9.8 N•m (7.2 lb-ft)**.

16. Put the original inflator into the box the new one came in. Make sure there is no other hardware in the box because if the package rattles, it will not be accepted by the courier.

17. Follow the shipping instructions supplied with the inflator kit to return the undeployed inflator. If you have any questions about shipping, call Warranty Parts Inspection (WPI) at **937-642-2737**.

18. Give the warranty clerk the inflator serial number that you wrote down in step 1. For the warranty claim to be paid, your warranty clerk must enter the serial number in the Diagnostic Trouble Codes field on the warranty claim.

END