

This Service Program replaces SP 365-001
(USA139200206) dated 7.17

Date	Group	No.	Release	Page
7.2017	365	001	02	1(3)

Vehicle ECU, Reprogramming
VN

SP 365-001, Vehicle ECU, Reprogramming

(July 2017)

On Certain Volvo Trucks with the AMTF transmission, using transmission PTO1, there could be grinding when engaging PTO or PTO will not remain engaged when shifting from "drive or reverse" to "neutral". This is due to a VECU SW issue. To correct this issue follow the procedure below:

Vehicle ECU, Reprogramming Procedure

You must read and understand the precautions and guidelines in Service Information, group 30, "General Safety Practices, Electrical" before performing this procedure. If you are not properly trained and certified in this procedure, ask your supervisor for training before you perform it.

NOTE: Information is subject to change without notice. Illustrations are used for reference only and can differ slightly from the actual vehicle being serviced. However, key components addressed in this information are represented as accurately as possible.

- 1 Park the vehicle on a flat and level surface.
- 2 Apply the parking brake.
- 3 Place the transmission in neutral or park.
- 4 Install the wheel chocks.

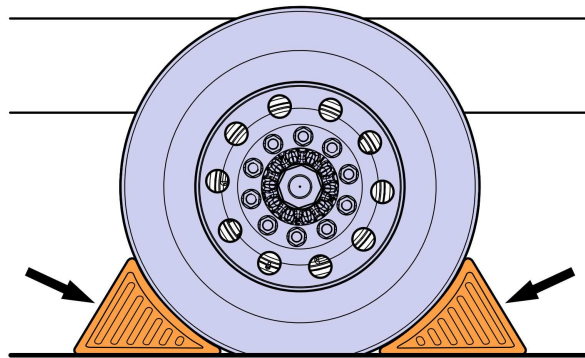

W7086748

- 5 Using Premium Tech Tool (PTT), connect to the vehicle.
- 6 Run Accessory kit 85151972.
- 7 Reprogram the VECU, MID144.
Note: Follow the on screen prompts until the programming is complete.
- 8 Disconnect the vehicle from Premium Tech Tool (PTT).
- 9 Remove the wheel chocks.

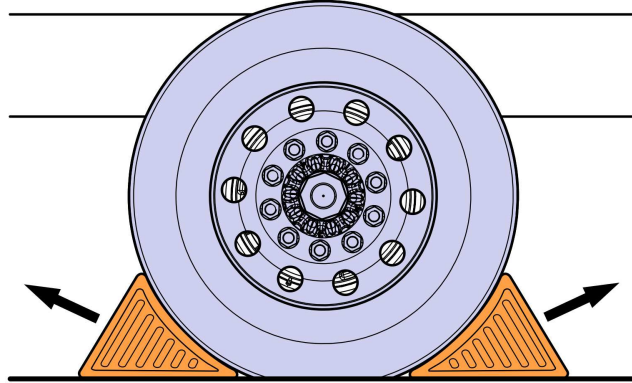

W7086759

Reimbursement

This repair is covered by an authorized Service Program. Reimbursement is obtained via the normal claim handling process.	UCHP Reimbursement
Claim Type (used only when uploading from the Dealer Bus. Sys.)	B
Recall Status	
Vehicle inspected, repair not required	
Vehicle repaired per instruction	
Labor Code	
Primary Labor Code (Vehicle ECU, Reprogramming)	3651-22-09-02 0.3 hrs
Take to take charge and determine campaign status	1700-16-01-01 0.3 hrs
Causal Part	22592366
SCC Code	S7188
Authorization Number	NA
Expiration Date	July 31, 2018

|