

JTB00570NAS1

# TECHNICAL BULLETIN

08 JUN 2017



© Jaguar Land Rover North America, LLC

NOTE: The information in Technical Bulletins is intended for use by trained, professional Technicians with the knowledge, tools, and equipment required to do the job properly and safely. It informs these Technicians of conditions that may occur on some vehicles, or provides information that could assist in proper vehicle service. The procedures should not be performed by 'do-it-yourselfers'. If you are not a Retailer, do not assume that a condition described affects your vehicle. Contact an authorized Jaguar service facility to determine whether this bulletin applies to a specific vehicle.

## INFORMATION

---

## SECTION:

501-25A: Body Repairs - General Information

---

**SUBJECT/CONCERN:**

Creak Noise From the Rear of the Vehicle When Accelerating, Braking, and/or Cornering

---

**AFFECTED VEHICLE RANGE:**

<b>MODEL:</b>	<b>MODEL YEAR:</b>	<b>VIN:</b>	<b>ASSEMBLY PLANT:</b>
F-PACE (X761)	2017	045591-061340	Solihull

---

**MARKETS:**

NORTH AMERICA

---

**CONDITION SUMMARY:****SITUATION:**

A creak noise may be evident from the rear of the vehicle when braking, accelerating, and/or cornering.

**CAUSE:**

This may be caused by deformation of body panels.

**ACTION:**

Should a Customer express this concern, follow the Service Instruction below.

---

**PARTS:****NOTES:**

- \* - An allowance is provided to cover the cost of the zinc-rich etch primer and felt tape.
- The felt tape is sourced from the Squeaks & Rattles kit.

PART NUMBER	DESCRIPTION	QUANTITY:
*ZZZ001	Zinc-rich primer	\$3.75 [USD]
*ZZZ001	1.6mm thick Felt tape	\$6.00 [USD]

---

#### WARRANTY:

#### NOTES:

- Repair procedures are under constant review, and therefore times are subject to change; those quoted here must be taken as guidance only. Always refer to TOPIx to obtain the latest repair time.
- The JLR Claims Submission System requires the use of causal part numbers. Labor only claims must show the causal part number with a quantity of zero

DESCRIPTION	SRO	TIME (HOURS)	CONDITION CODE	CAUSAL PART
Cross brace creak - Weld	76.96.50	1.6	07	T4A1726

#### NOTE:

Normal Warranty procedures apply.

**COMPONENT LOCATION**

---

1



E208872

Location of the repair.

**SERVICE INSTRUCTION:**

---

**NOTE:**

For further information on the methods, tools and fixings used in this procedure, see TOPIx Workshop Manual section 501-25A: Body Repairs - General Information.

1

**NOTE:**

Repeat this step on both sides of the vehicle.

Remove the Loadspace Side Trim Panel for access only (see TOPIx Workshop Manual section 501-05: Interior Trim and Ornamentation - Loadspace Trim Panel).

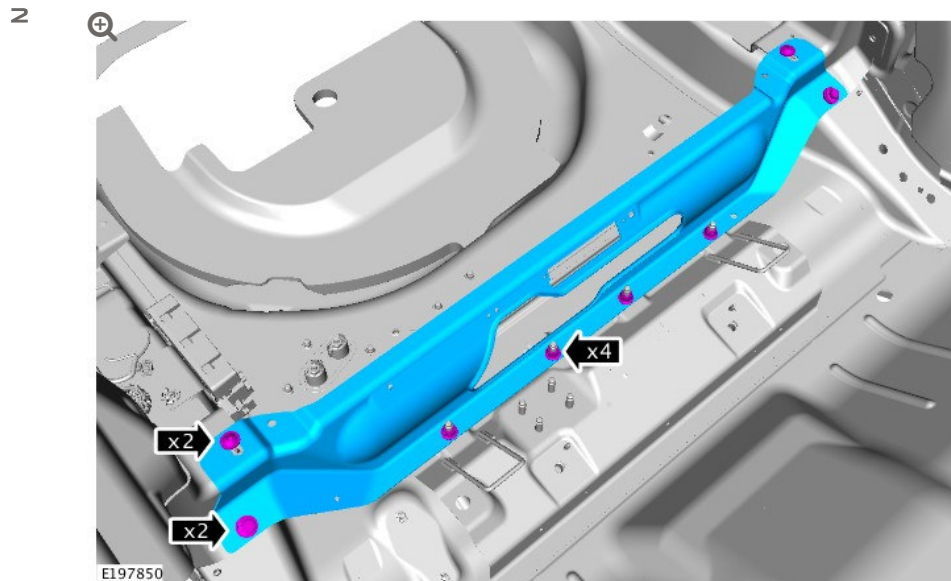

Remove the cross brace.

- Remove the 4 retaining bolts.
- Remove the 4 retaining nuts.
- Torque: **48 Nm**.

3

**NOTE:**

Repeat this step on both sides of the vehicle.

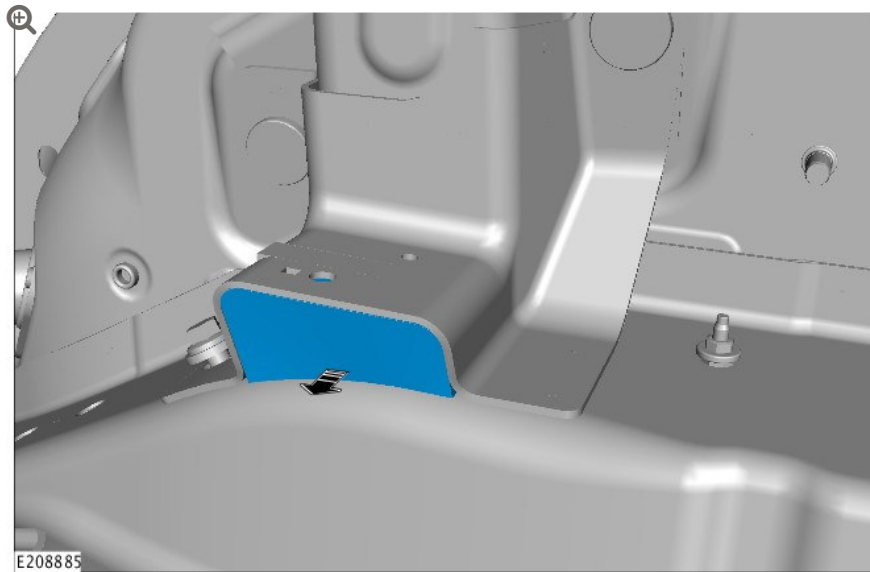

Remove the foam Noise, Vibration and Harshness (NVH) insulator.



#### CAUTIONS:

- Make sure a locally sourced zinc-rich primer is applied to any bare metal surfaces.
- Make sure the surrounding area is protected to avoid damaging the vehicle.
- Body panels which have been modified/alterd must be returned to their original manufacturing condition.

#### NOTES:

- Paint the area that has been welded.
- Some components shown removed for clarity.
- Repeat this step on both sides of the vehicle.

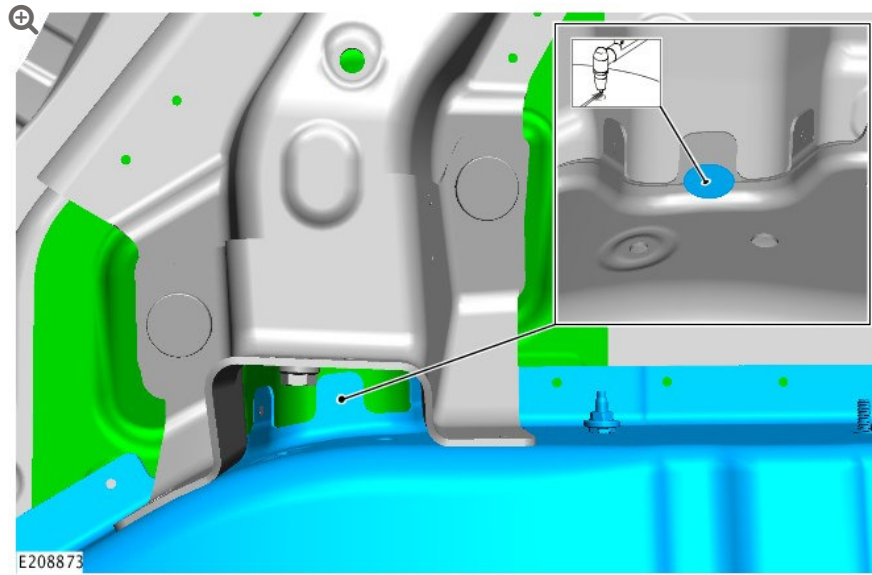

Using the appropriate welding equipment, apply a weld to the seam as shown.

---

5

**CAUTION:**

**Make sure that the area is clean before installing the felt tape.**

**NOTE:**

**The felt tape is sourced from the Squeaks & Rattles kit.**

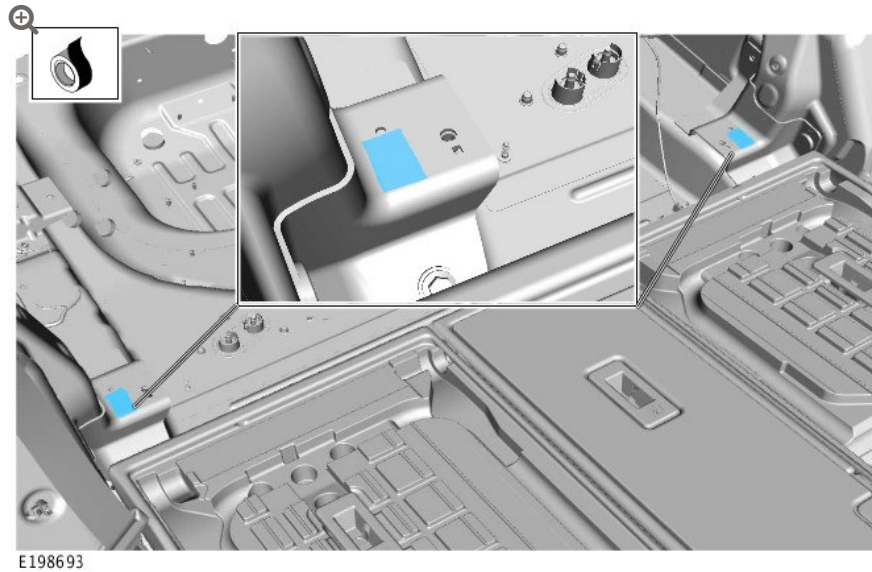

Cut 2 lengths of 1.6mm thick felt tape and apply to the panel as shown.

6

**CAUTION:**

**Make sure that the area is clean before installing the felt tape.**

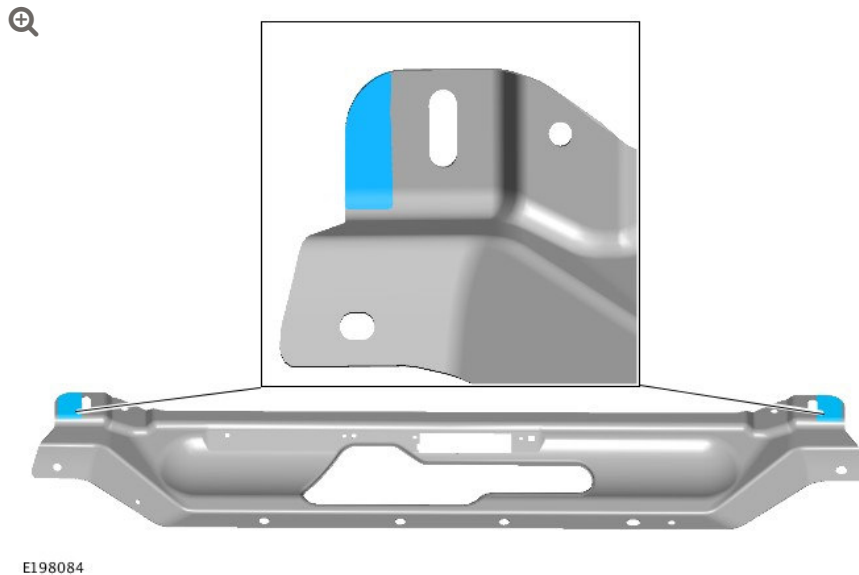



Cut 2 lengths of 1.6mm thick felt tape and apply to the cross brace in the locations as shown .

- 
- To install, reverse the removal procedure.