

November 11, 2014

BTB 00256 (1411)

## Steering Vibration/Moan While Turning at Idle or Low Speeds

### AFFECTED VEHICLES

Year	Model	Trim	VIN Range
2010-13	MDX	ALL	ALL

### SYMPTOM

The vehicle's body and steering wheel vibrates while it's at idle or very low speed when turning the steering wheel..

### POSSIBLE CAUSES

The high pressure demand from the steering gearbox on the power steering pump causes a vibration in the accessory drive belt system.

### CORRECTIVE ACTION

Replace the alternator pulley.

### PARTS INFORMATION

Part Name	Part Number	Quantity
Decoupler Alternator Pulley	31141-RV0-A01	1
Decoupler Alternator Cap	31142-RV0-A01	1

### TOOL INFORMATION

Tool Name	Tool Number	Quantity
Alternator OAD Pulley Holder	07AAB-TK8A100	1

### WARRANTY CLAIM INFORMATION

The normal warranty applies.

Operation Number	Description	Flat Rate Time	Template ID	Failed Part Number
1181A8	Replace the alternator pulley.	0.6 hr	14-039N	31141-RV0-A01

Defect Code: 00401

Symptom Code: 05501

Skill Level: Repair Technician

**CLIENT INFORMATION:** The information in this bulletin is intended for use only by skilled technicians who have the proper tools, equipment, and training to correctly and safely maintain your vehicle. These procedures should not be attempted by "do-it-yourselfers," and you should not assume this bulletin applies to your vehicle, or that your vehicle has the condition described. To determine whether this information applies, contact an authorized Acura automobile dealer.

## REPAIR PROCEDURE

1. Remove the engine cover.
2. Remove the drive belt.
3. Remove the A/C suction line from the brackets.

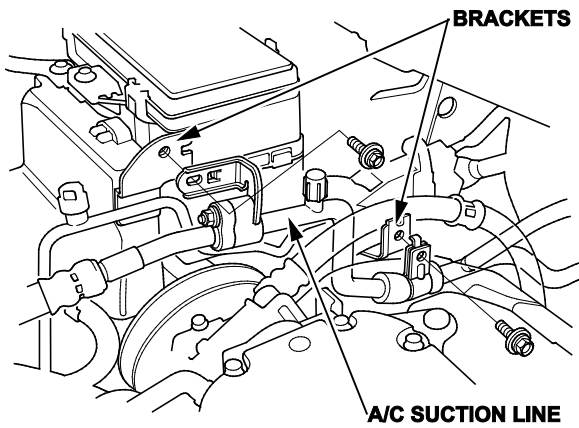

4. Remove the coolant reservoir, then remove the power steering fluid reservoir from the bracket.
5. Remove the pulley locknut with a 22 mm wrench and a 10 mm wrench, then remove the alternator pulley.

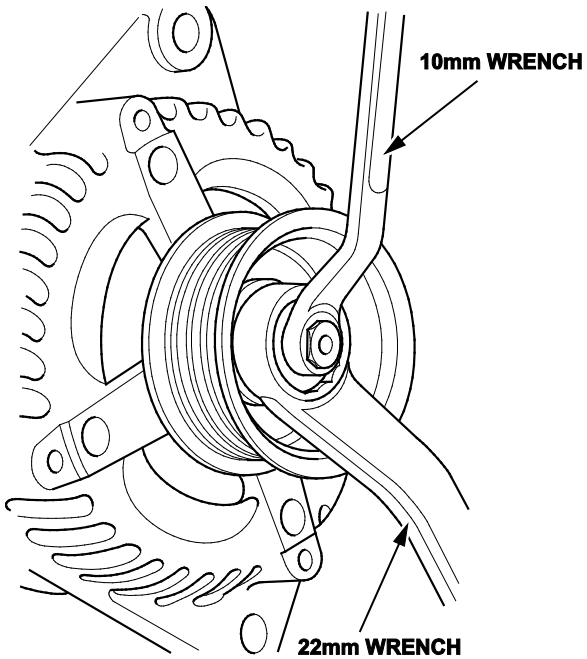

6. Install the new decoupler alternator pulley by threading it onto the alternator shaft. Then insert the alternator OAD pulley holder into the decoupler pulley.

NOTE: The new decoupler alternator pulley is threaded internally; the nut will no longer be used.

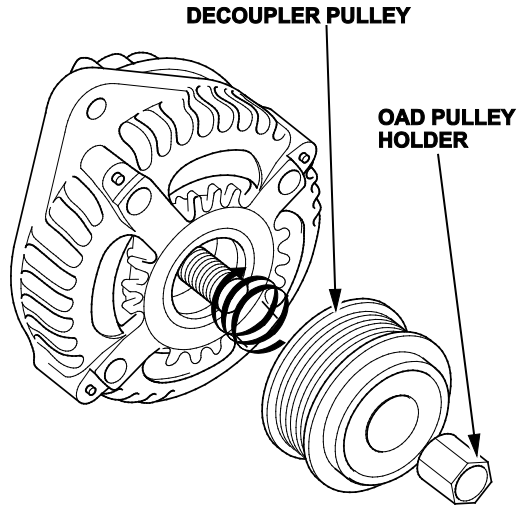

7. Hold the alternator OAD pulley holder with a 17 mm wrench. Place a 10 mm deep socket wrench through the center of the alternator OAD pulley holder onto the hex on the end of the alternator shaft, then torque the alternator shaft counterclockwise to **80 N·m (59 lb-ft)**.

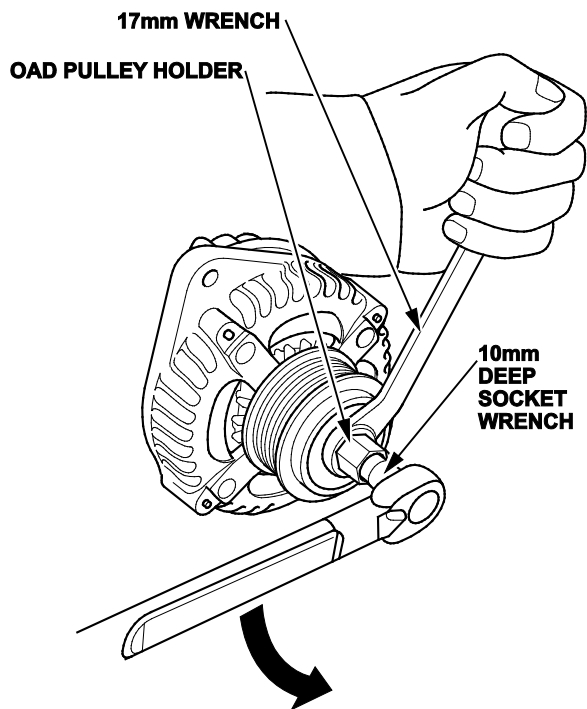

8. Install the new decoupler pulley cap.

NOTE: Make sure the new decoupler pulley cap is installed securely.

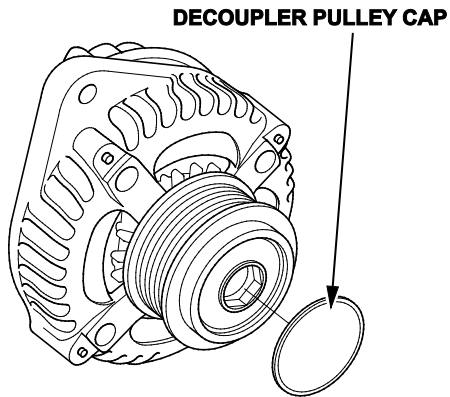

9. Install the power steering fluid reservoir to the bracket, then install the coolant reservoir.
10. Install the A/C suction line to the bracket bolt and torque it to **12 N·m (8.8 lb-ft)**.
11. Install the drive belt.
12. Install the engine cover.

END