



GROUP
ELE

MODEL
2016MY
Soul EV (PS EV)

NUMBER
138

DATE
September 2017

TECHNICAL SERVICE BULLETIN

SUBJECT: SERVICE ACTION: OBC REPLACEMENT (SA307)

This bulletin provides the procedure to replace the On-Board Charger (OBC) on some 2016MY Soul EV (PS EV) vehicles, produced from January 16, 2015 through December 21, 2015, which may exhibit a malfunction indicator light (MIL) ON with DTCs P1CF5 and P1CF6 due to a battery charge delay with the OBC. To correct this concern, replace the OBC, even if the related DTCs are not present.

Before conducting this procedure, verify that the vehicle is included in the list of affected VINs.

DTC	Description
P1CF5	GRID Check
P1CF6	EVSE Check

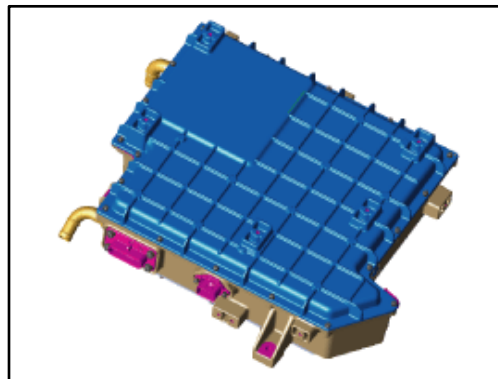

★ NOTICE

A Service Action is a repair program without customer notification that is performed during the warranty period. Any dealer requesting to perform this repair outside the warranty period will require DPSM approval.

Repair status for a VIN is provided on WebDCS (Service → Warranty Coverage → Warranty Coverage Inquiry → Campaign Information). Not completed Recall / Service Action reports are available on WebDCS (Consumer Affairs → Not Completed Recall → Recall VIN → Select Report), which includes a list of affected vehicles.

This issue number is SA307.

File Under: <Electrical>

Circulate To: General Manager Service Manager Parts Manager
 Service Advisors Technicians Body Shop Manager Fleet Repair

Replacement Procedure:**⚠ DANGER**

When performing this procedure, follow all EV battery safety procedures found in the “Service Materials → Service Info → EV Battery System → General Safety Information and Caution” chapter in the applicable Shop Manual on KGIS, and wear all required Personal Protection Equipment (PPE).

Replace the OBC by referring to the “Soul EV → EV Battery System → High Voltage Charging System → On-Board Charger (OBC) → Repair procedures” chapter in the applicable Shop Manual on KGIS.

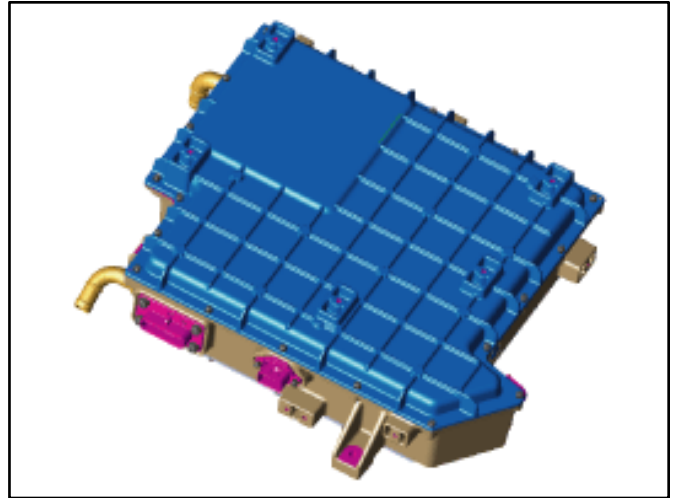
*** NOTICE**

After OBC replacement with the QKQ part, KDS will display an available software update.

For the 58 specific VINs in this Service Action, this update is NOT required.

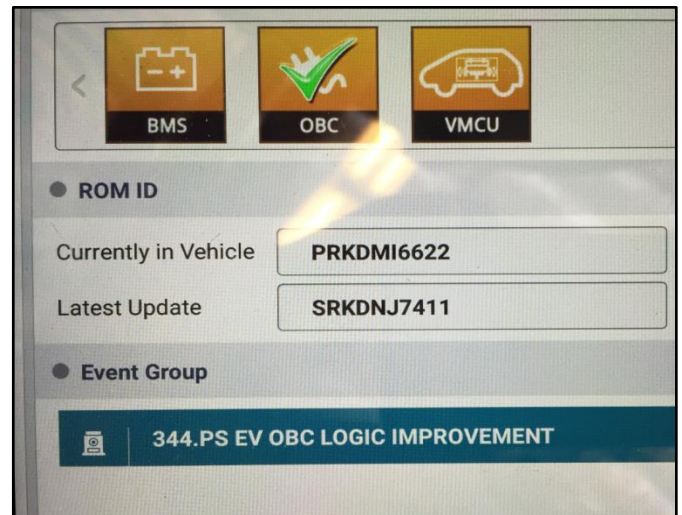

SUBJECT:

SERVICE ACTION: OBC REPLACEMENT (SA307)

AFFECTED VEHICLE RANGE:

Model	Production Date Range
Soul EV (PS EV)	January 16, 2015 through December 21, 2015

REQUIRED PART:

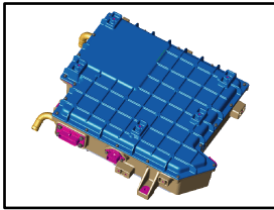
Part Name	Part Number	Figure
On-Board Charger	36400 0E040QQK	

WARRANTY INFORMATION:

N Code: N99 C Code: C99

Claim Type	Causal P/N	Qty.	Repair Description	Labor Op Code	Op Time	Replacement P/N	Qty.
V	36400 0E040	0	(SA307) On-Board Charger Replacement	160060R0	1.5 M/H	36400 0E040QQK	1

*** NOTICE**

VIN inquiry data for this repair is provided for tracking purposes only. Kia retailers should reference SA307 when accessing the WebDCS system.