



SERVICE BULLETIN

Classification: AT17-005a	Reference: NTB17-064a	Date: August 24, 2017
------------------------------	--------------------------	--------------------------

2013 – 2017 ALTIMA AND PATHFINDER; SHIFT LOCK SOLENOID REMOVAL AND INSTALLATION

This bulletin has been amended to change the PFP in the Claims Information. Please discard all previous versions of this bulletin.

APPLIED VEHICLES: 2013 – 2017 Altima Sedan (L33)
2013 – 2017 Pathfinder (R52)
2014 – 2015 Pathfinder Hybrid (R52)

SERVICE INFORMATION

If an Applied Vehicle needs the shift lock solenoid replaced for any reason, use the Service Procedure in this bulletin.

Nissan Bulletins are intended for use by qualified technicians, not 'do-it-yourselfers'. Qualified technicians are properly trained individuals who have the equipment, tools, safety instruction, and know-how to do a job properly and safely. **NOTE:** If you believe that a described condition may apply to a particular vehicle, DO NOT assume that it does. See your Nissan dealer to determine if this applies to your vehicle.

SERVICE PROCEDURE

REMOVAL

1. Remove the CVT shift selector from the vehicle.
 - Refer to the appropriate Electronic Service Manual (ESM), section TM-Transaxle & Transmission, for CVT shift selector removal information.

2. Using a suitable tool, release pawls (A) and remove park position switch (shift selector) bracket (B).

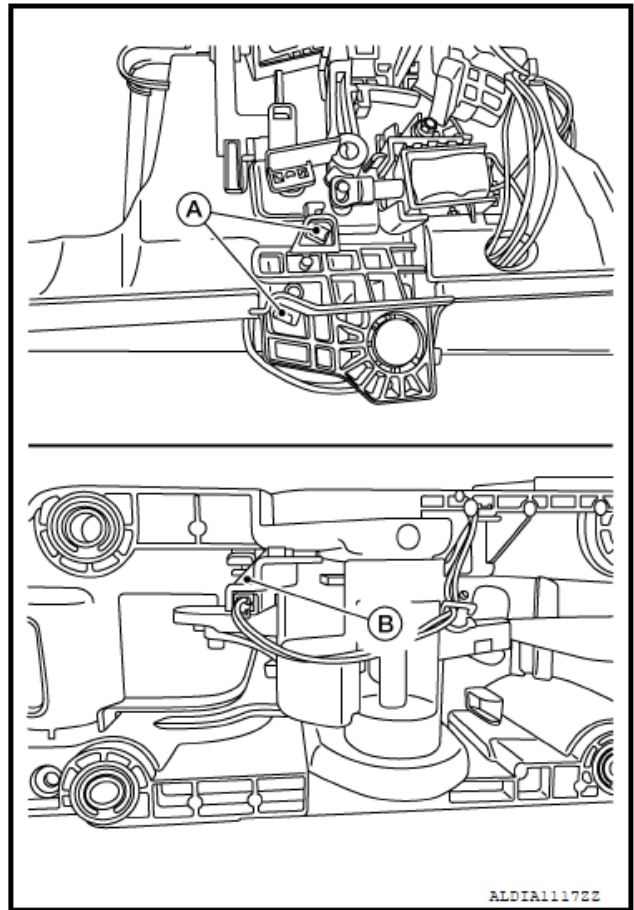

Figure 1

3. Using a suitable tool, release pawls (A) and remove park position switch [shift selector (B)] from park position switch (shift selector) bracket (C).

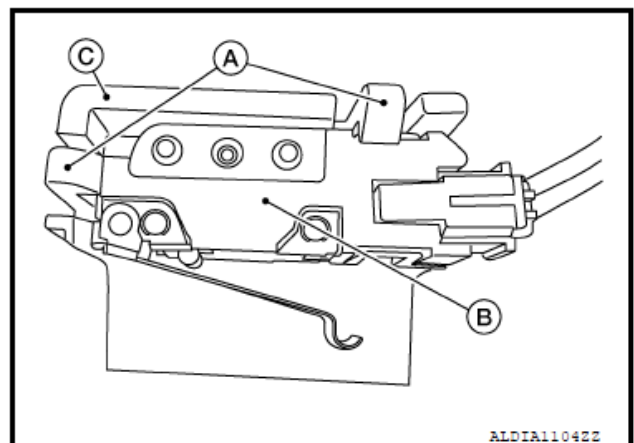

Figure 2

4. Separate shift lock solenoid harness (A) from clip (B).

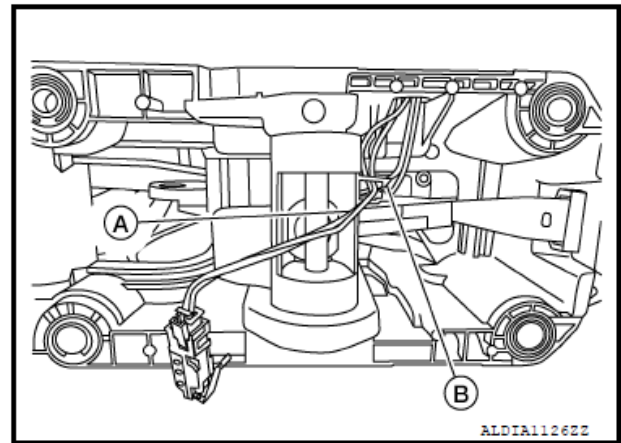

Figure 3

5. Pull park position switch [shift selector (A)] through opening (B) as shown (➡).

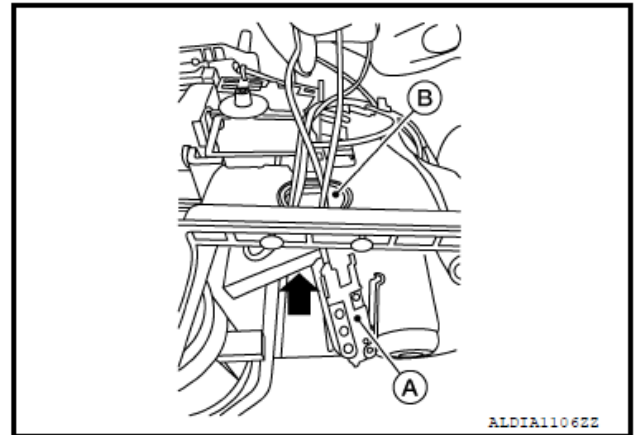

Figure 4

6. Using a suitable tool release pawls (A) and remove park position switch (B) from park position switch bracket (C).

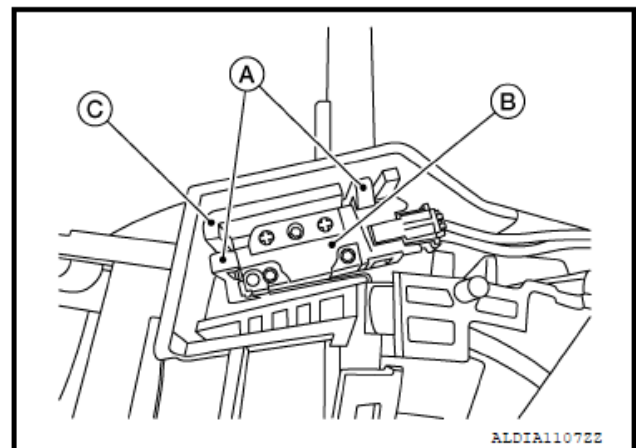

Figure 5

7. If equipped; remove lock washer (A).
- Use suitable tool (B) to squeeze, bend, or break, and remove lock washer (A).

CAUTION:

- Do not damage shaft (C) while removing lock washer.
- DO NOT reuse lock washer.
- The new solenoid includes a new lock washer to be used only if one is removed.

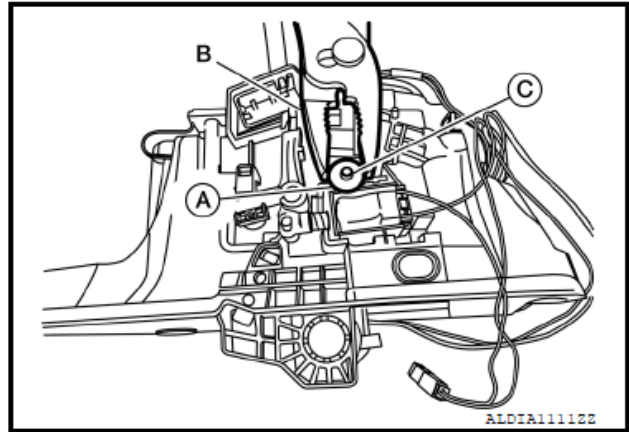

Figure 6

8. Using suitable tool (A) release pawl (B), then use suitable tool (C) to remove shift lock solenoid (1).

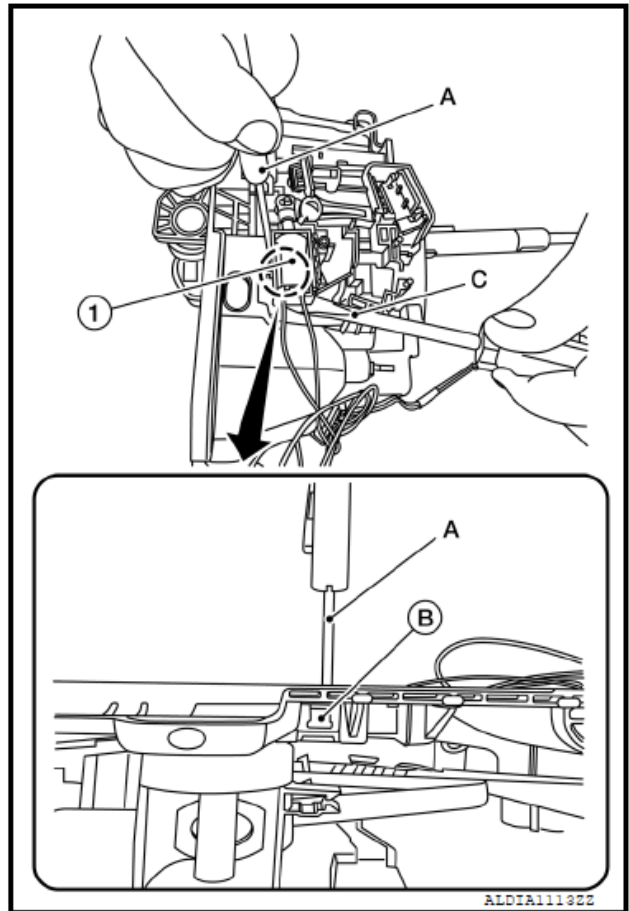

Figure 7

9. Remove shift lock solenoid harness (A) from clip (B).

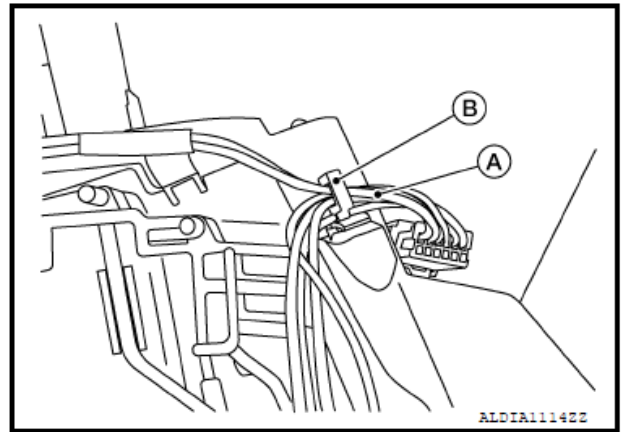



Figure 8

10. Using suitable tool (A) release pawl and remove shift lock solenoid harness (B) from CVT shift selector (1).

 = Pawl

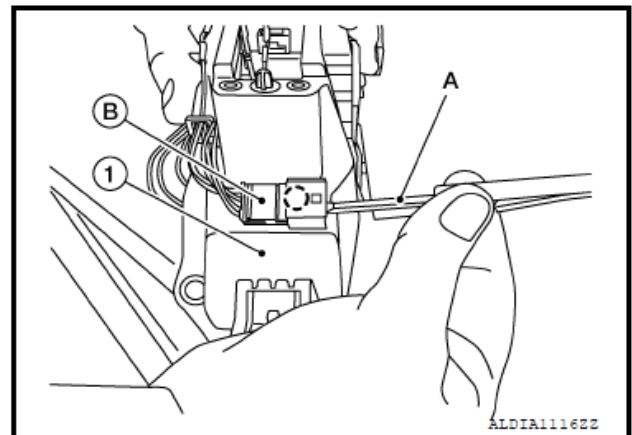

Figure 9

11. For models equipped with an overdrive switch, perform the following steps:

- a. Using suitable tool (A) release connector lock (B).

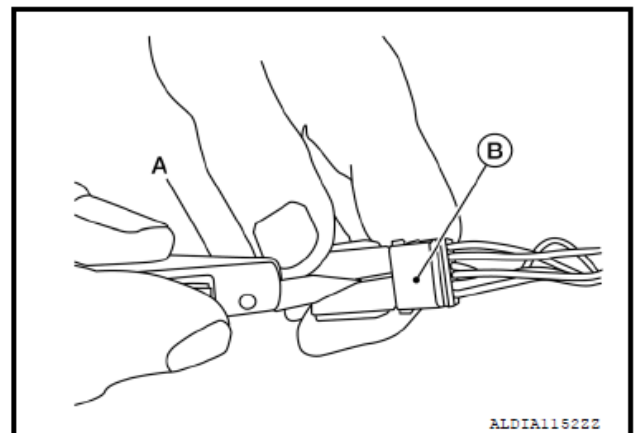

Figure 10

- b. Using suitable tool (A) release overdrive switch pin (B) from connector (C) and remove overdrive switch pin as shown (➡).

- Repeat step “b” for second overdrive switch pin.

NOTE: Both overdrive switch pins have the same color wire. Mark one wire with a suitable marker so that it can be reinstalled in the same location.

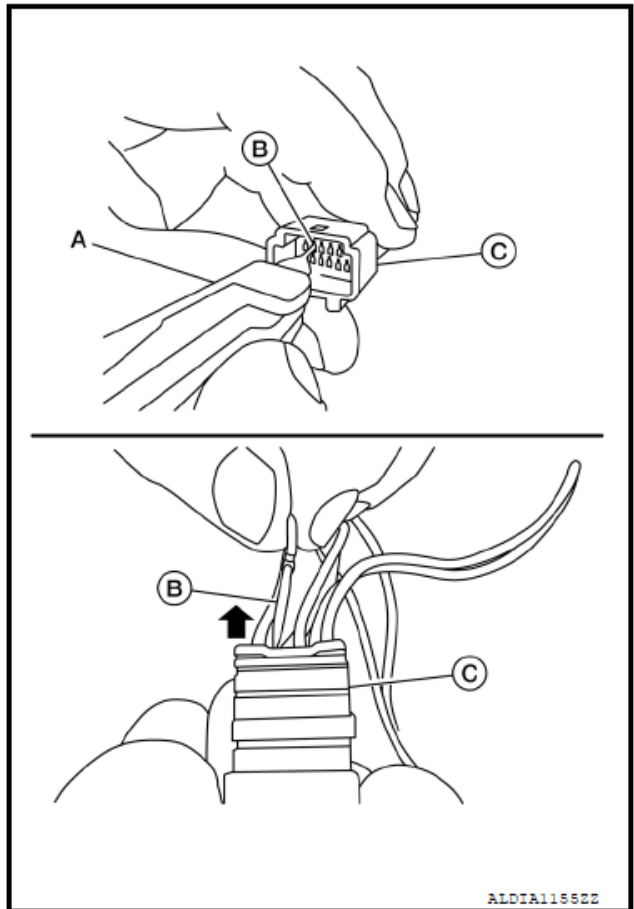

Figure 11

INSTALLATION

1. For models equipped with an overdrive switch perform the following steps.
 - a. Install overdrive switch pin (A) into connector (B) as shown (➡).
 - b. Repeat step “a” for the second overdrive switch pin.

NOTE: Use the mark that was made when removed to insert pins into the original locations.

CAUTION: DO NOT bend the pins during insertion.

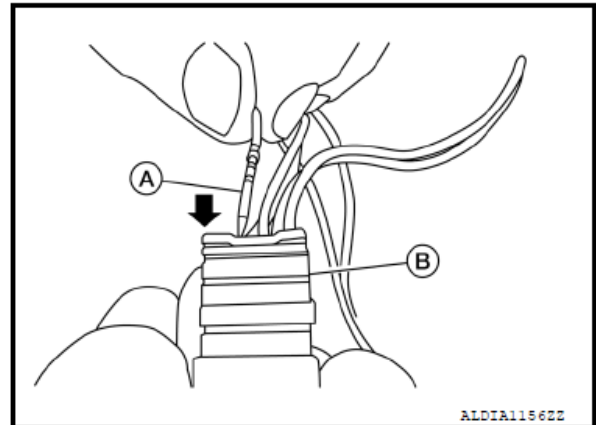

Figure 12

- c. Install connector lock (A) to locked position.

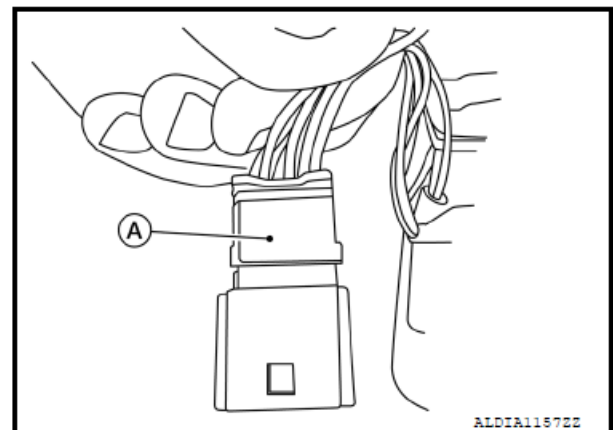

Figure 13

2. Install shift lock solenoid harness (A) onto CVT shift selector (1).

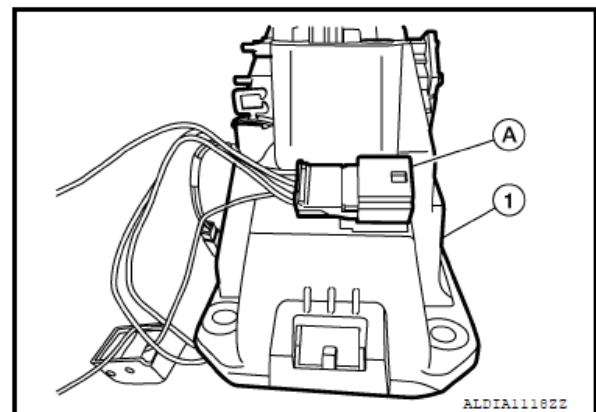

Figure 14

3. Install shift lock solenoid harness (A) to clip (B).

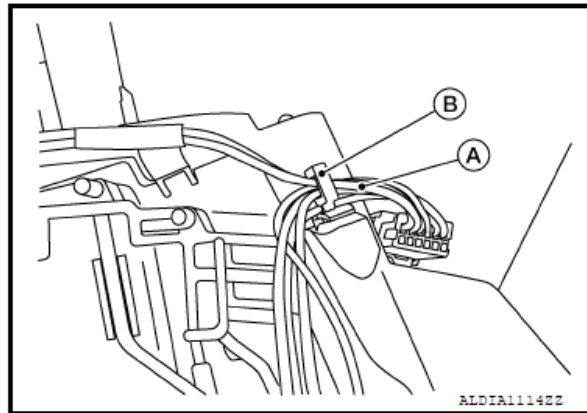

Figure 15

4. Align opening (A) to pin (B) and install shift lock solenoid (1).

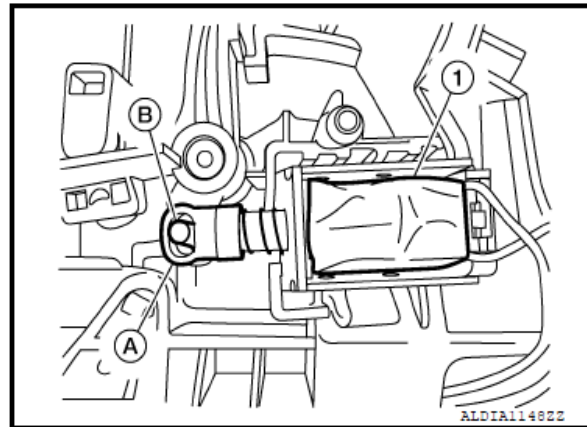

Figure 16

5. If equipped: Install a new lock washer (A).

- Only install the lock washer if one was removed (refer to step 7 on page 4).
- The new solenoid includes a new lock washer to be used **only if one was removed**.

CAUTION: Do not reuse the old lock washer.

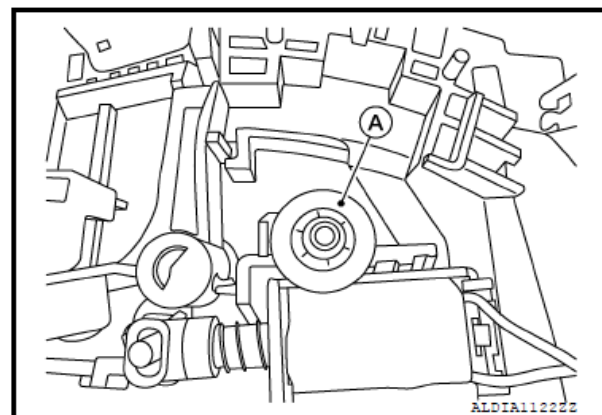

Figure 17

- Align park position switch (B) with alignment pins (A) and install park position switch to park position switch bracket (C).

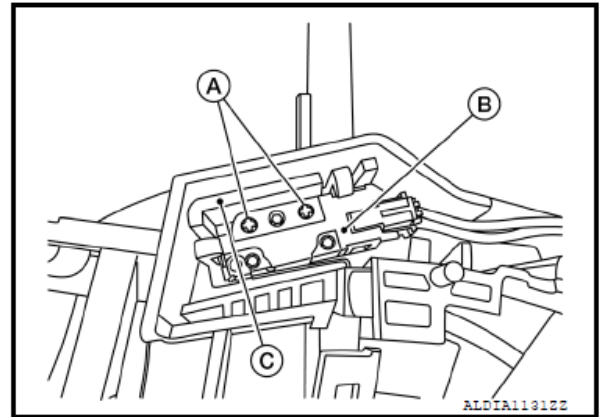

Figure 18

- Install park position switch [shift selector (A)] through opening (B) as shown (➡).

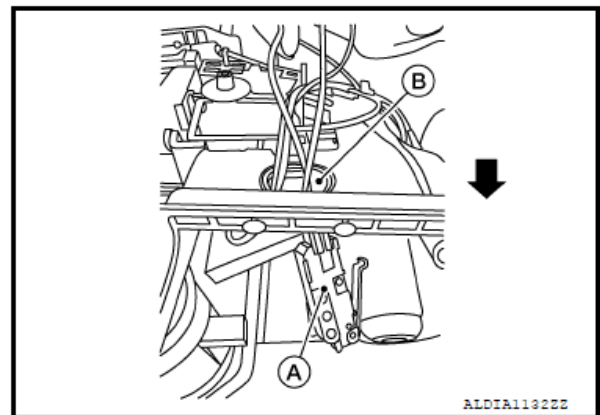

Figure 19

- Install shift lock solenoid harness (A) to clip (B).

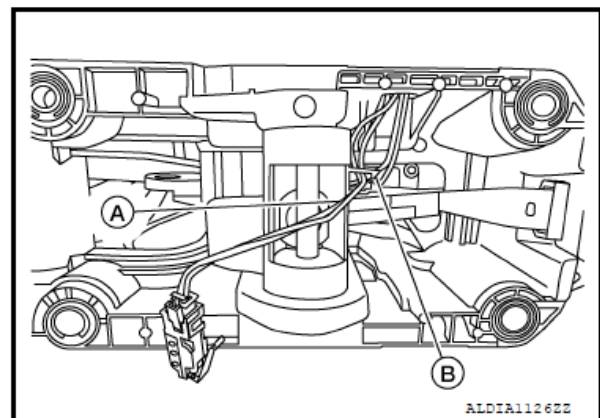

Figure 20

9. Align park position switch [shift selector (B)] with alignment pins (A) and install park position switch (shift selector) to park position switch (shift selector) bracket (C).

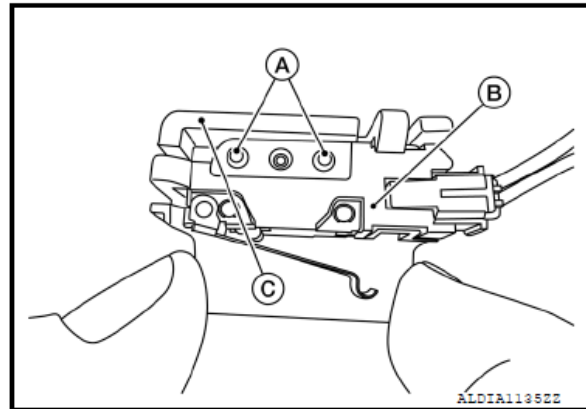

Figure 21

10. Install park position switch (shift selector) bracket pawls (A) park position switch (shift selector) bracket (B).

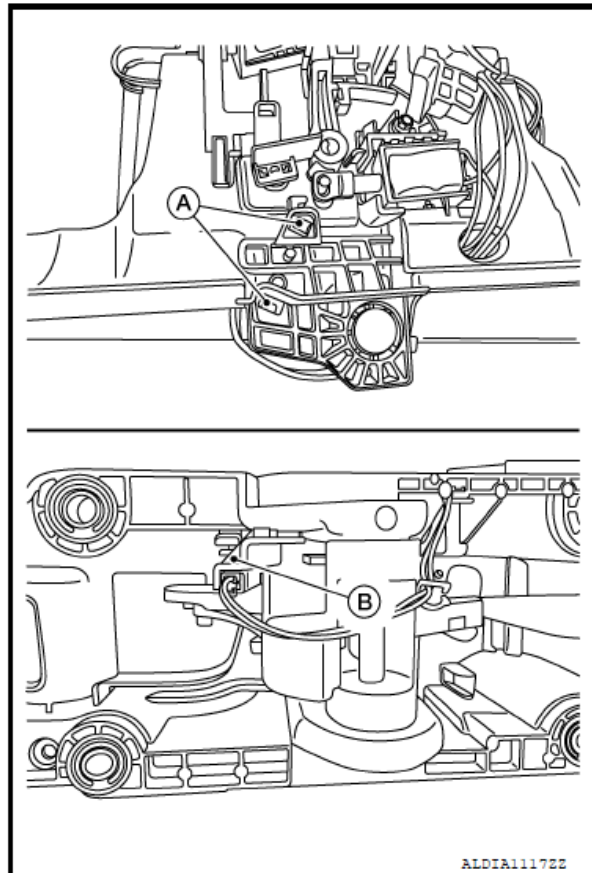

Figure 22

11. Reinstall the CVT shift selector into the vehicle in reverse order of removal.

- If needed, refer to the appropriate ESM, section TM-Transaxle & Transmission, for CVT shift selector installation information.

PARTS INFORMATION

DESCRIPTION	PART NUMBER	QUANTITY
SOL ASSY - SELECT LOCK (Shift Lock Solenoid; includes lock washer)	34970 – 3TA2A	1

CLAIMS INFORMATION

Submit a Primary Part (PP) type line claim using the following claims coding:

DESCRIPTION	PFP	OP CODE	SYM	DIA	FRT
Replace Shift Lock Solenoid	34970-3TA2A	JE70AA	(1)	(1)	(2)

- (1) Reference the current Nissan Warranty Flat Rate Manual and use the applicable Symptom (SYM) and Diagnostic (DIA) codes.
- (2) Reference the current Nissan Warranty Flat Rate Manual and use the indicated Flat Rate Time (FRT).

