



The 2016 Audi TT Roadster Sales and After Sales

Audi of America, LLC
Service Training
Created in the U.S.A.
Created 5/2015
Course Number 600275
©2015 Audi of America, LLC

All rights reserved. Information contained in this manual is based on the latest information available at the time of printing and is subject to the copyright and other intellectual property rights of Audi of America, LLC., its affiliated companies and its licensors. All rights are reserved to make changes at any time without notice. No part of this document may be reproduced, stored in a retrieval system, or transmitted in any form or by any means, electronic, mechanical, photocopying, recording or otherwise, nor may these materials be modified or reposted to other sites without the prior expressed written permission of the publisher. All requests for permission to copy and redistribute information should be referred to Audi of America, LLC.

Always check Technical Bulletins and the latest electronic service repair literature for information that may supersede any information included in this booklet.

eMedia



This eSSP contains video links which you can use to access interactive media.

Contents

Introduction	1
Body	6
Body reinforcements	8
Convertible top	10
Overview	10
Displays and operation of convertible top	13
Convertible top opening sequence	19
Convertible top closing sequence	21
Wind deflector	25
Emergency operation of convertible top	26
Passive safety	28
Components	28
Engine and power transmission	30
Chassis	31
Climate control	33
Introduction	33
Seat systems	34
Head area heater	35
Service	36
Inspection and maintenance	36
Notes	37
Self study programs	38
Knowledge assessment	39

This eSelf Study Program teaches a basic knowledge of the design and functions of new models, new automotive components or technologies.

It is not a Repair Manual! All values given are intended as a guideline only.

For maintenance and repair work, always refer to the current technical literature.



Note



Reference

Introduction

The third generation TT Roadster marks the continuation of a great tradition. The designers at Audi have re-interpreted the styling of this classic vehicle and complemented it with innovative new components.

Like the 2016 TT Coupe, the Roadster will feature a 2.0L TFSI engine and DSG transmission as well as quattro.

The flat and taut top of the TT Roadster provides a clear contrast with the body and is defined by the short side window design that is typical of the Roadster. The TT is equipped with an electrically operated fabric top.

The body shell of the new TT Roadster represents a new evolution of the Audi Space Frame (ASF) based on the modular transverse matrix (MQB). Compared with the Coupe, the body of the Roadster has been modified in key areas. Ultra-high strength components made from hot-stamped steel reinforce the front end and the occupant cell floor. Aluminium is used in the cell as well as in all outer skin parts and attachments in the form of three typical semi-finished products – die-cast nodal elements, extruded profiles and sheet metal.

The new TT Roadster combines the dynamic ride of a sports car with the driving experience of an open top two-seater. This was accomplished in part by struts in the underbody and body that enhance torsional rigidity and thus ride comfort.

The innovative new Audi virtual cockpit will also be standard on the TT Roadster. This new display and control concept received the Car Connectivity Award and the Interior Innovation of the Year at the 2014 Automotive Interiors Expo Awards.



Here is a quick summary of the features of 2016 TT Roadster explained in detail in this Self-Study Program.

Engine

Four cylinder engine with turbocharger:

- ▶ 2.0L TFSI 220 hp (169 kW).

Assistance systems

The following systems are optionally available:

- ▶ Audi side assist.
- ▶ Park assist system with ambient display.



Climate control

All control functions of the automatic climate control air conditioning system are integrated into the air vents. The air conditioning system has small displays which show the selected setting.

The Audi TT Roadster is optionally available with sport seats including a head space heater.

Body

Audi Space Frame (ASF) body made from aluminum and steel with high-strength and ultra-high-strength steel alloys, die-cast aluminum nodal elements and side panels.

Internal steel ribbing ensures the aluminum sills have high-strength properties. V-shaped steel struts reinforce the zones underneath the engine compartment and the luggage compartment, and connect the axle carriers.



631_043

Power transmission

Full-time quattro drive – systematically developed and refined for the TT – with electro-hydraulic multiplate clutch on the rear axle. It is possible to customize the all-wheel drive characteristics with Audi drive select.

Occupant safety systems

Rigid rollover bars protect the occupants in the event of a rollover. The front side airbags (head-thorax airbags) protect the occupants in the event of a side impact.

Displays and operation

Fully digital Audi virtual cockpit instrument cluster with dynamic animations and graphics. New MMI control panel on the center tunnel console with 2 toggle buttons. On each side of the central rotary pushbutton, there are two buttons together with a main menu button and a back button. Touch-sensitive touch pad on the top of the rotary pushbutton.

Convertible top

Electrically actuated convertible top. Graphical display of convertible top operation in Audi virtual cockpit. A power operated wind deflector improves ride comfort when driving with the top down.

Chassis

Electro-mechanical progressive steering, where the steering ratio becomes more direct with increasing steering input.

Dimensions

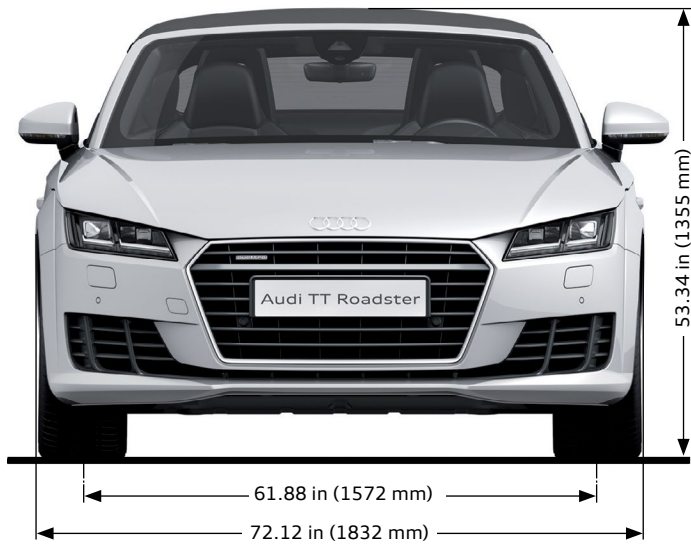

631_065

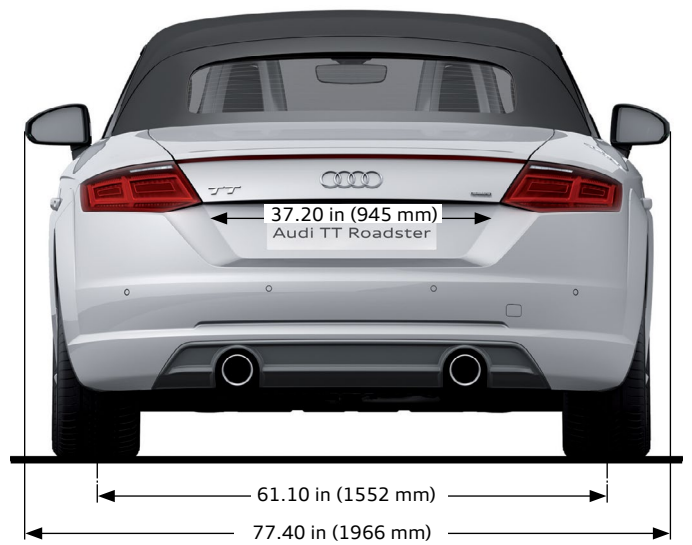

631_066

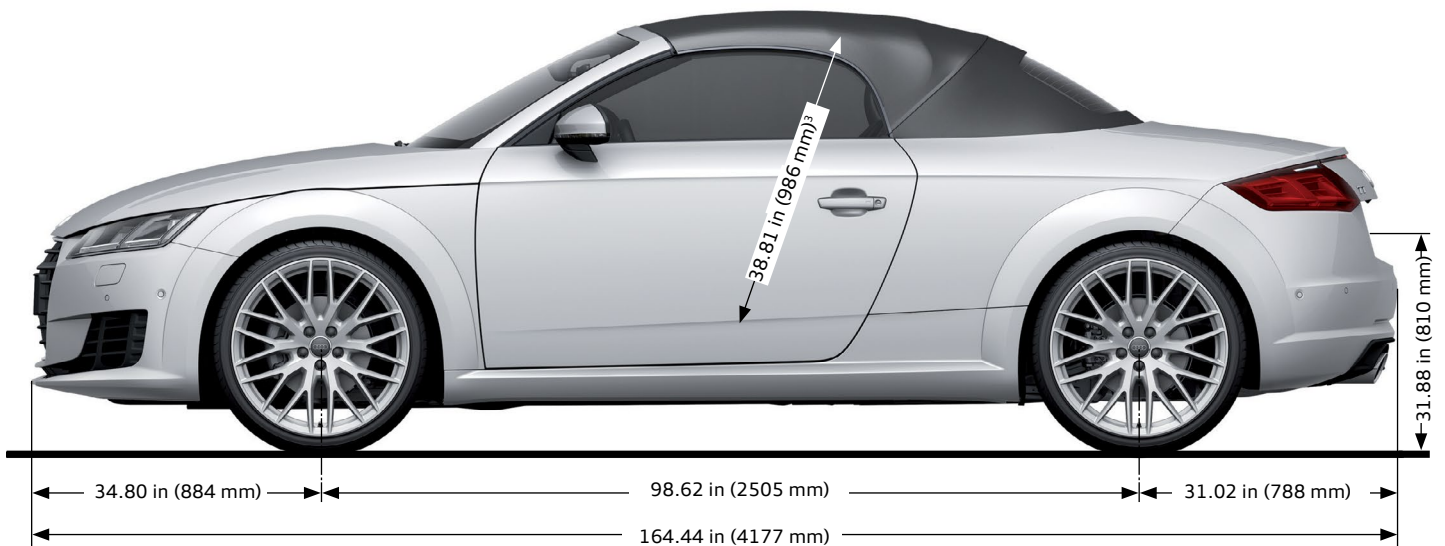

631_067

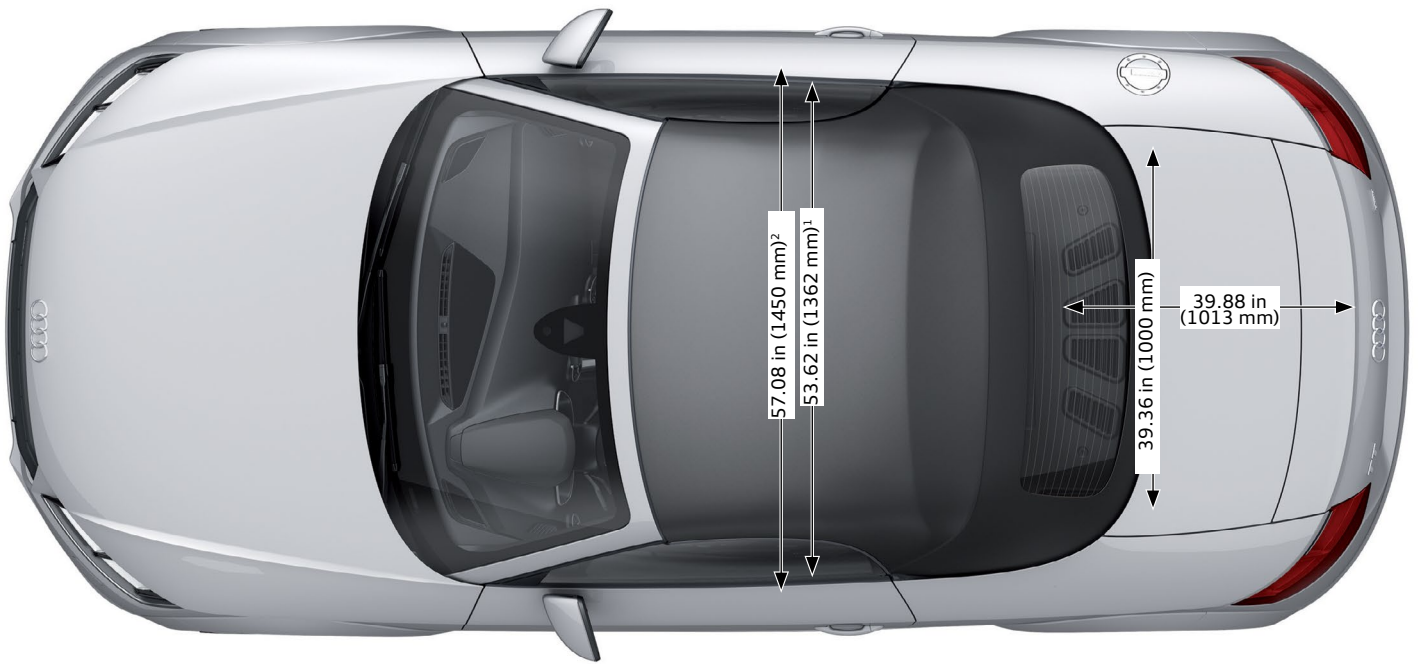

631_068

Exterior dimensions and weights

Length in (mm)	164.44 in (4177 mm)
Width in (mm)	72.12 in (1832 mm) ⁴⁾
Height in (mm)	53.34 in (1355 mm)
Front track width in (mm)	61.88 in (1572 mm)
Rear track width in (mm)	61.10 in (1552 mm)
Wheelbase in (mm)	98.62 in (2505 mm)
Curb weight lb (kg)	3384 (1535) ⁵⁾
Gross vehicle weight lb (kg)	3990 (1810) ⁵⁾

Interior dimensions and other specifications

Front cabin width in (mm)	57.08 in (1450 mm) ²⁾
Front headroom in (mm)	38.81 in (986 mm) ³⁾
Front shoulder width in (mm)	53.62 in (1362 mm) ¹⁾
Rear headroom in (mm)	33.77 in (858 mm)
Through-loading width in (mm)	39.36 in (1000 mm)
Load sill height in (mm)	31.88 in (810 mm)
Drag coefficient c_w	0.30 ⁶⁾
Capacity of fuel tank in gal (L)	14.5 gal (55 l)

¹⁾ Shoulder room width

²⁾ Elbow room width

³⁾ Maximum headroom

⁴⁾ Excluding mirror

⁵⁾ With 2.0l TFSI engine, quattro, 6-speed DSG transmission

⁶⁾ When the convertible top is closed

All dimensions are given in inches and millimeters and refer to the unladen weight of the vehicle.

Body

The bodyshell of the TT Roadster is based on the modular transverse matrix (MQB). Ultra high strength components made from hot-stamped steel reinforce the front end and the occupant cell floor. Aluminum is used in the cell as well as in all outer skin parts and attachments in the form of three typical semi-finished products - die-cast nodal elements, extruded profiles and sheet metal. In total, 50% cold formed steel and 11% hot formed steel are used in the new TT Roadster.

The 37% share of aluminum is distributed as follows:

- ▶ 21% sheet aluminum.
- ▶ 8% die-cast aluminum.
- ▶ 8% aluminum profile.

Altogether, the body of the Audi TT Roadster including attachments weighs 741lbs (336kg). The crash safety performance of the TT Roadster is formidable due to the intelligent hybrid construction concept.

Outer skin

The entire outer skin of the Audi TT Roadster is made of aluminum. This includes:

- ▶ Front fenders.
- ▶ Side panels.
- ▶ Hood attachments.
- ▶ Doors.
- ▶ Trunk lid.

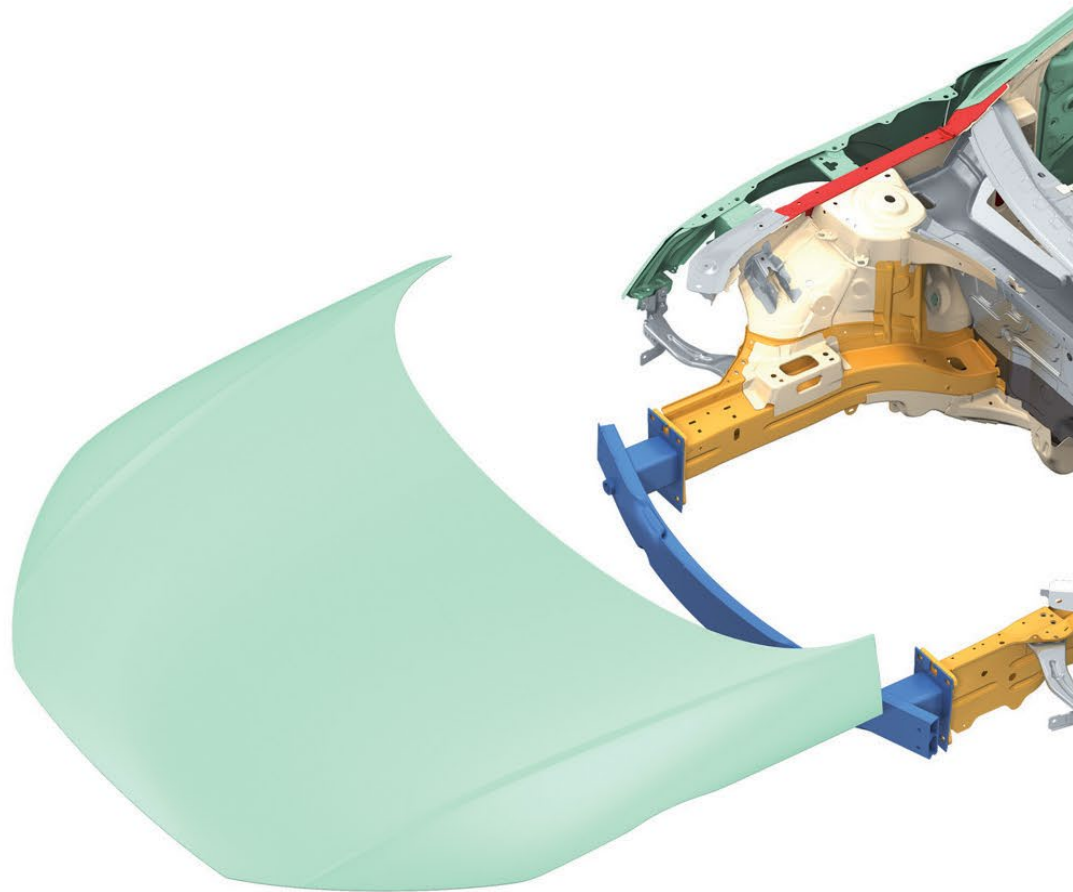

Key:

- Sheet aluminum
- Die-cast aluminum
- Aluminum section
- Ultra-high strength steel (hot-formed)
- Advanced high strength steel
- High strength steel
- Low strength steel

Design

The occupant cell of the Audi TT Roadster weighs 119 lb (54 kg). It is an aluminum lattice structure where 10 castings form the nodal points of the bodyshell.

There are large nodal elements at the A-pillars that connect the sill, window cross member and the upper longitudinal section in the front end.

The following components are made of die-cast aluminum:

- ▶ A-pillar.
- ▶ Top front roof frame nodal element.
- ▶ Inner B-pillar.
- ▶ Inner B-pillar connecting part.
- ▶ Rear roof frame nodal element.

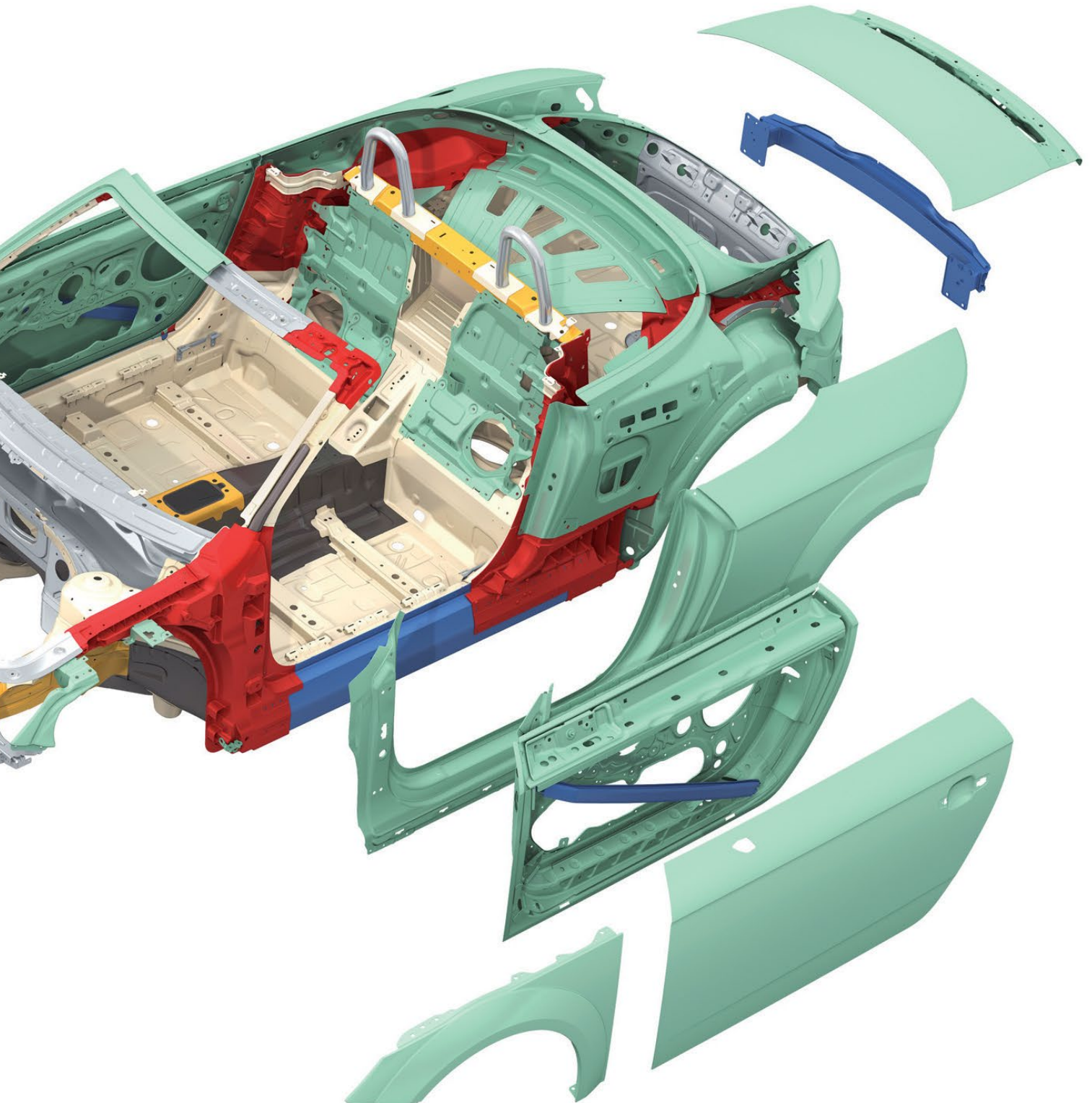

Body reinforcements

A-pillar

Compared with the Coupe, the body of the TT Roadster has been modified in key areas. To provide additional stiffening, an inner panel made of high strength steel and a reinforcing tube are concealed behind the die-cast aluminum A-pillars.

The reinforcing tube is made from ultra high strength hot stamped steel. These components offer the occupants a high level of safety in the event of a rollover.

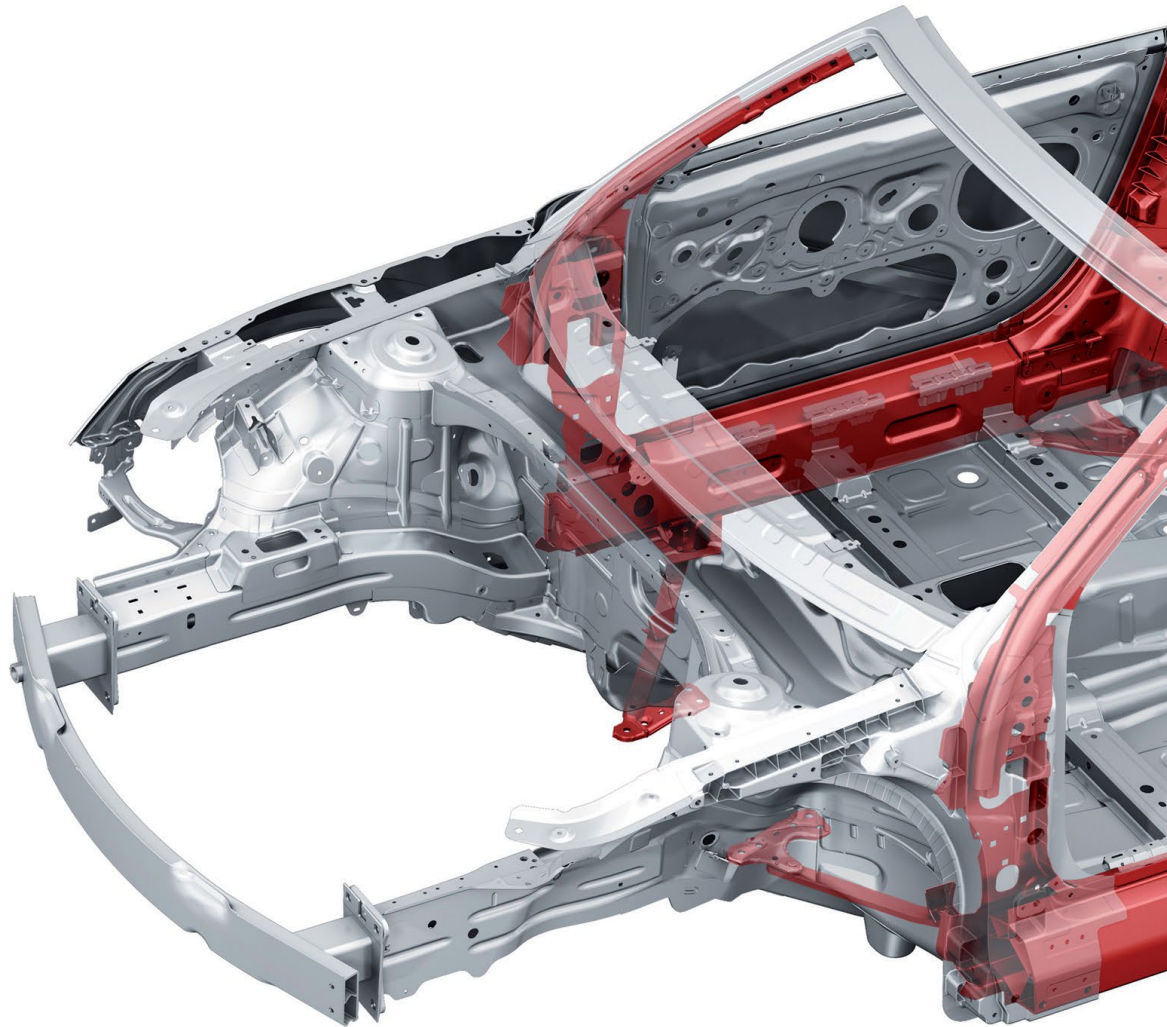

Diagonal struts

Additional V-shaped steel struts reinforce the front and rear axle carriers and connect them to the bodyshell. These supporting measures provide a high level of vehicle rigidity and help reduce the transfer of vibration to the passenger compartment.

Sound-absorbing pan

The Audi TT Roadster has an aluminum sound-absorbing pan, which not only reinforces the front end structure, but also provides added sound insulation.

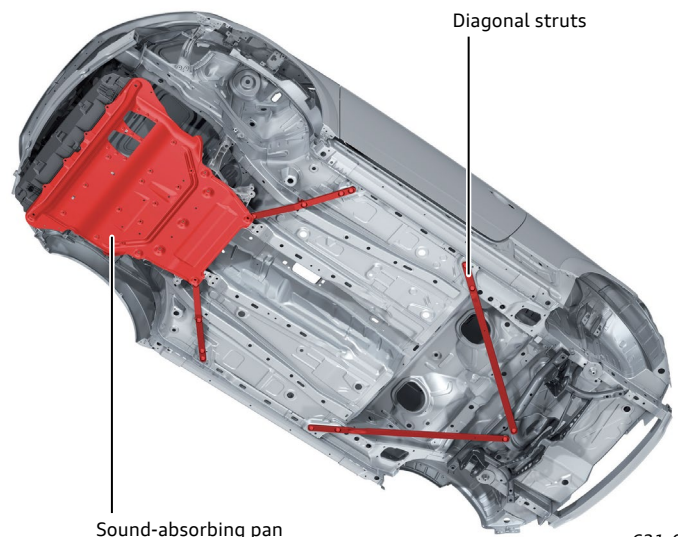

Rear bulkhead

In the Audi TT Roadster, a solid bulkhead made of two box profiles separates the occupant cell from the luggage compartment and replaces the bottom cross member found on the Coupe. The top section of the bulkhead houses the steel rollover bars, a well-known and classic design feature of the Roadster.

Mounting plates seal the openings in the rear bulkhead, which features through-loading as standard.

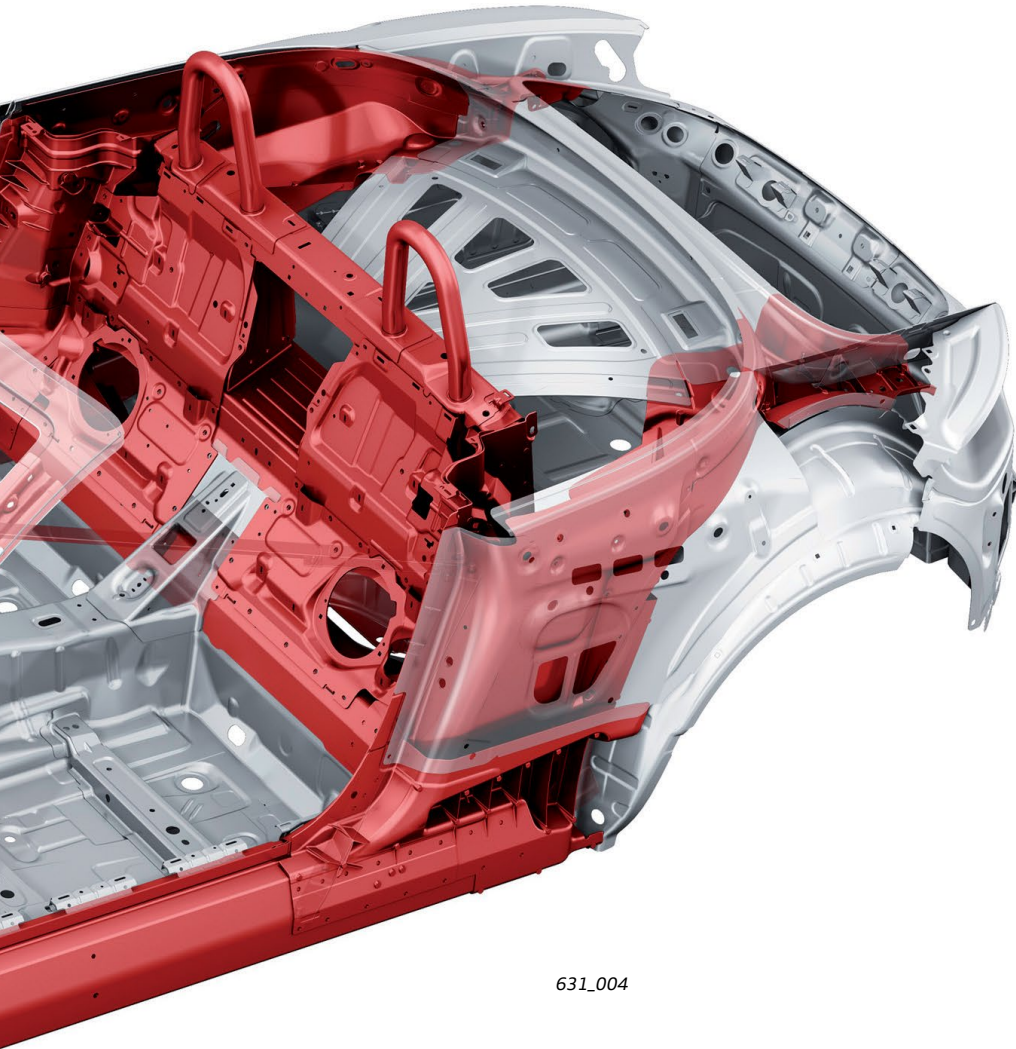

631_004

Door sills of the Audi TT Coupe

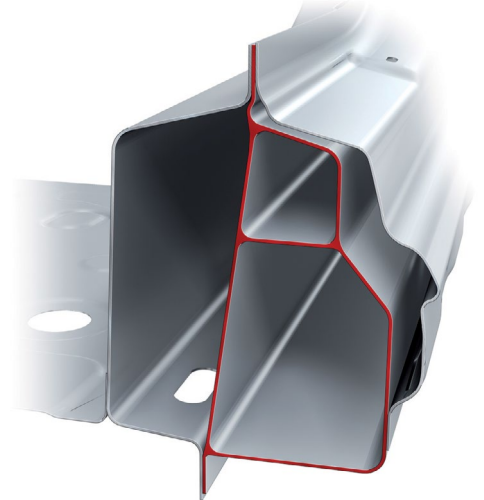

631_081

Door sills of the Audi TT Roadster

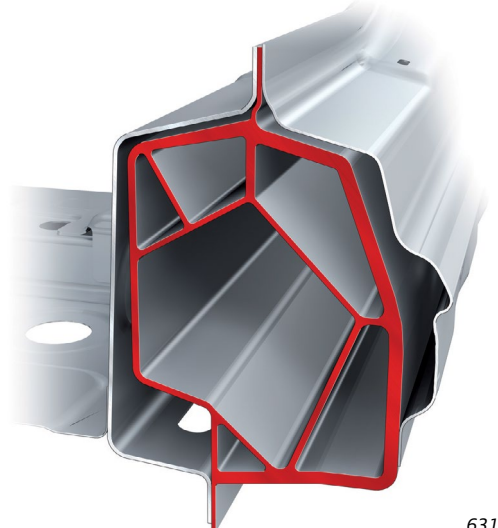

631_082

Door sill

The door sills made from extruded aluminum profiles give extra strength.

Due to the absence of a roof structure, it is necessary for the door sills of the TT Roadster to be thicker and be integrated into the structure by means of die-cast nodes in the B-pillar. The modified interior geometry provides much higher strength.

Convertible top

Overview

The new Audi TT Roadster features a classical soft top with a Z fold system. While opening, the soft top forms a -Z shape as it folds together into a flat package, which is stored in an aluminum tray behind the seats.

A feature of this space-saving folding system is that the front section of the soft top folds over the fabric as a cover and locks flush with the vehicle body.

With parts made from magnesium, aluminum, steel and plastic, the soft top weighs just 86 lb (39 kg).



Convertible top fabric

The convertible top fabric of the TT Roadster provides extremely good thermal insulation in addition to reducing noise levels - especially in the airflow frequency range.

The noise level in the interior has been reduced (depending on frequency) by up to 6 dB compared to the predecessor model. The radio antennas are integral with the convertible top and hidden from view.

Because of the elaborate clamping system of the roof, it is held completely taut even at high speeds and presents a homogeneous look that conceals the cross bows.

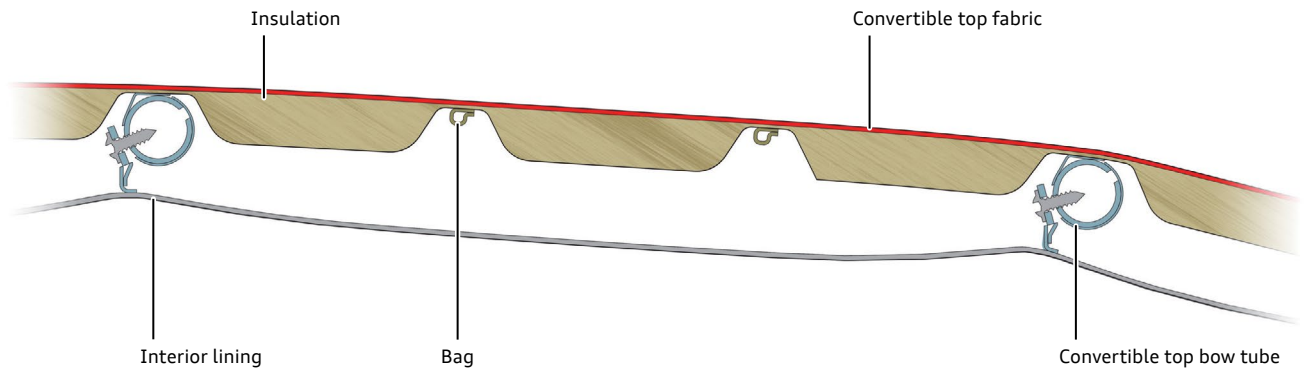

631_074



Rear window defroster

The heated glass rear window is a component part of the convertible top cover and cannot be replaced individually if damaged. In this case, the complete cover must be replaced.

Convertible top flaps

The side openings for the soft top mechanism drive are covered by the convertible top flaps, eliminating the need for a tonneau cover or convertible top box lid.



631_073



631_072

Wind deflector

To reduce airflow in the interior when the convertible top is open, the TT Roadster is equipped with an electrically extendable wind deflector.

It is possible to remove and install the wind deflector, its support, and the Convertible Wind Deflector Motor without removing the convertible top.

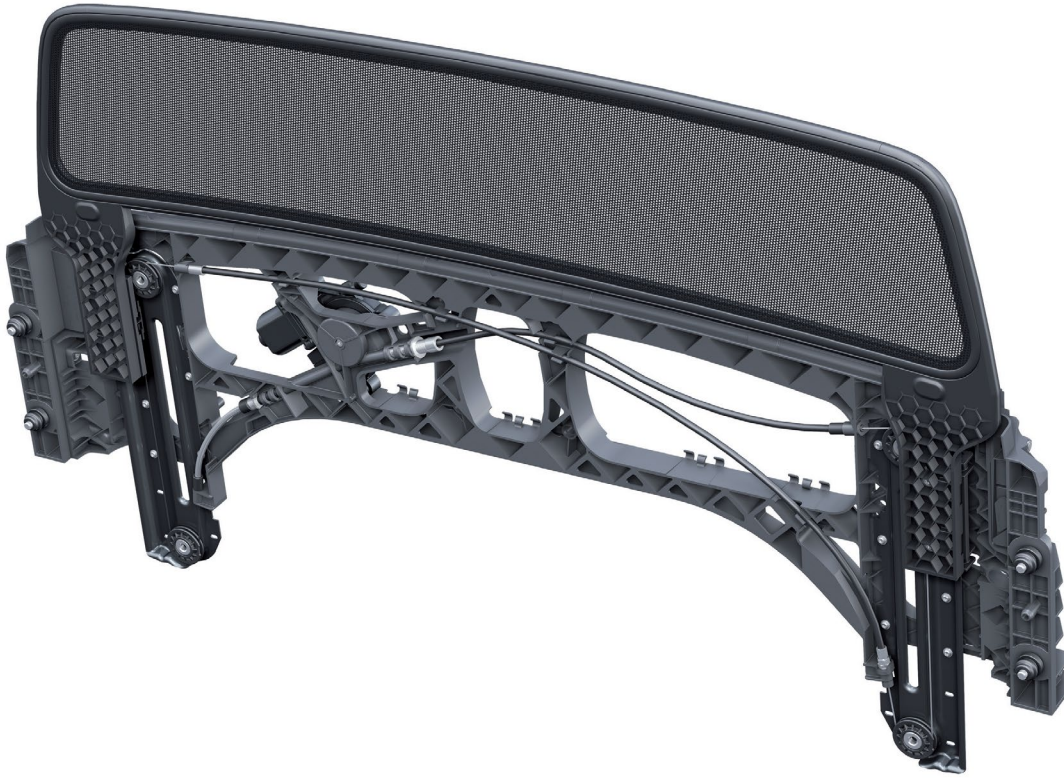

Displays and operation of convertible top

The convertible top of the TT Roadster has an all electric drive system. It is driven by two electric motors - one on each side of the vehicle - mounted on the main bearings of the top. Roof operation is controlled by the Convertible Top Control Module.

Basics of convertible top operation

The convertible top is operated by pressing and holding the Power Top Operation Switch until an opening or closing cycle is completed. This is referred to as “manual” operation.



631_007

Power Top Operation Switch

Convertible top operating cycle

During manual operation, the Power Top Operation Switch must be actuated continuously while the top operating cycle is in progress. If the switch is released, the operating cycle stops instantaneously. If the switch is activated again, the cycle is continued. However, the Convertible Top Control Module initiates a “soft starting” of the Convertible Top Motors.

The purpose of the “soft start” is to ensure top does not wobble or shudder when moving but rather that it starts evenly and smoothly.

Continuing to actuate the Power Top Operation Switch after the top has been fully opened or closed causes the side windows to close completely. Windows will stop moving if the switch is released.

Automatic operation of the convertible top is not possible when the vehicle is stationary or travelling faster than 31 mph (50 km/h).

Audi virtual cockpit display

There is no separate instrument panel indicator for the top operating cycle. Instead, when the operating cycle is started, the top position is displayed graphically in Audi virtual cockpit. Depending on the view setting, the displays are positioned either in the center or at the side.

A curved arrow over the convertible top indicates the direction in which the convertible top is moving:

- ▶ Arrow tip pointing backwards: convertible top is opening.
- ▶ Arrow tip pointing forwards: convertible top is closing.

The convertible top is shown in red, as is the case with an open door.



European instrument cluster shown.

631_031

Display for discontinued convertible top operating cycle

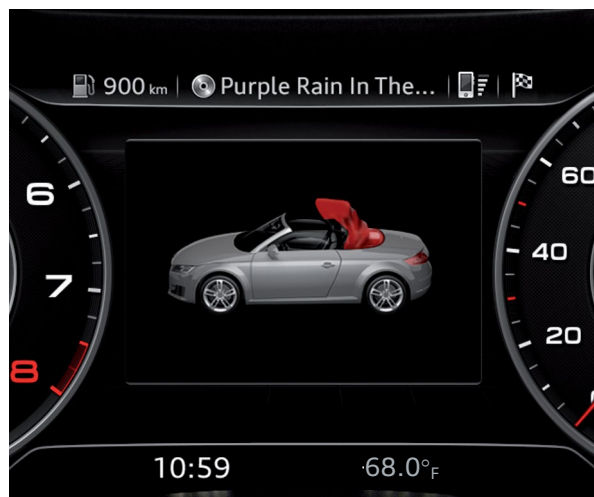

631_033

If no arrow is displayed over the convertible top, the convertible top operating cycle has been initiated but discontinued. The convertible top is therefore currently in an intermediate position.

Display for discontinued convertible top operating cycle

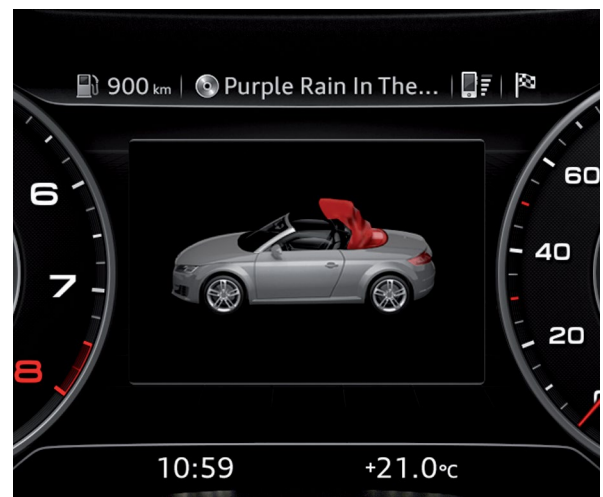

If no arrow is displayed over the convertible top, the convertible top operating cycle has been initiated but interrupted. The convertible top is therefore currently in an intermediate position.

Displays for complete convertible top operating cycle

When the top operating cycle is completed, the status (opened or closed) is indicated in the display for approximately two seconds and an audible signal sounds at the same time.

Convertible top operating cycle complete – convertible top open

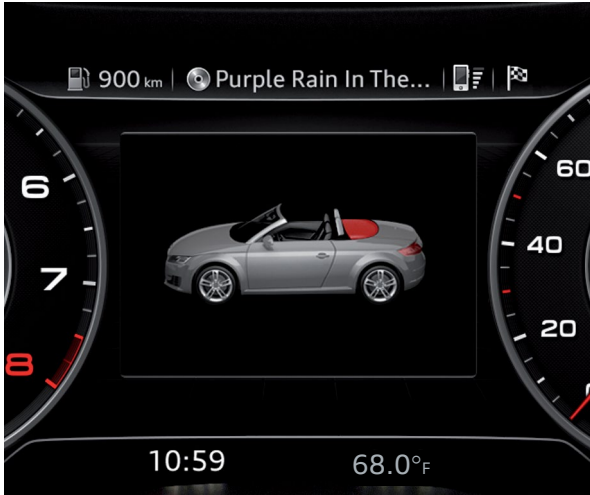

631_035

Convertible top operating cycle complete – convertible top closed

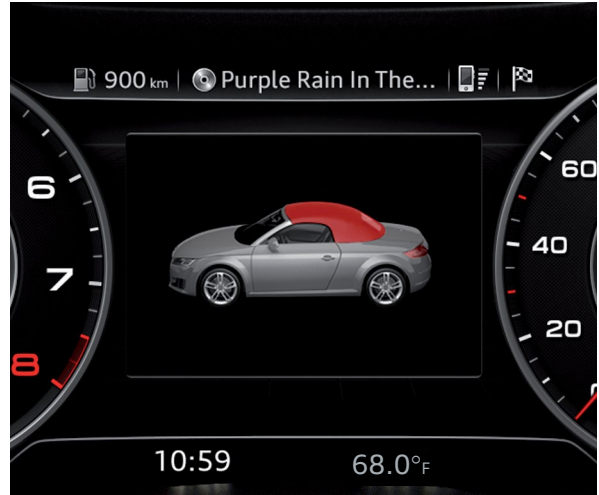

631_034

Displays when convertible top operation is not possible

If the convertible top cannot be operated, it is indicated in the instrument cluster. An audible signal sounds at the same time.

A warning is given and one of seven different messages is displayed.

Warning display

A warning is given if the top is in an intermediate position, the vehicle is travelling faster than 3 mph (5 km/h) and there is a static DTC fault code in the fault memory.

In addition to the warning, the yellow central warning lamp comes on.

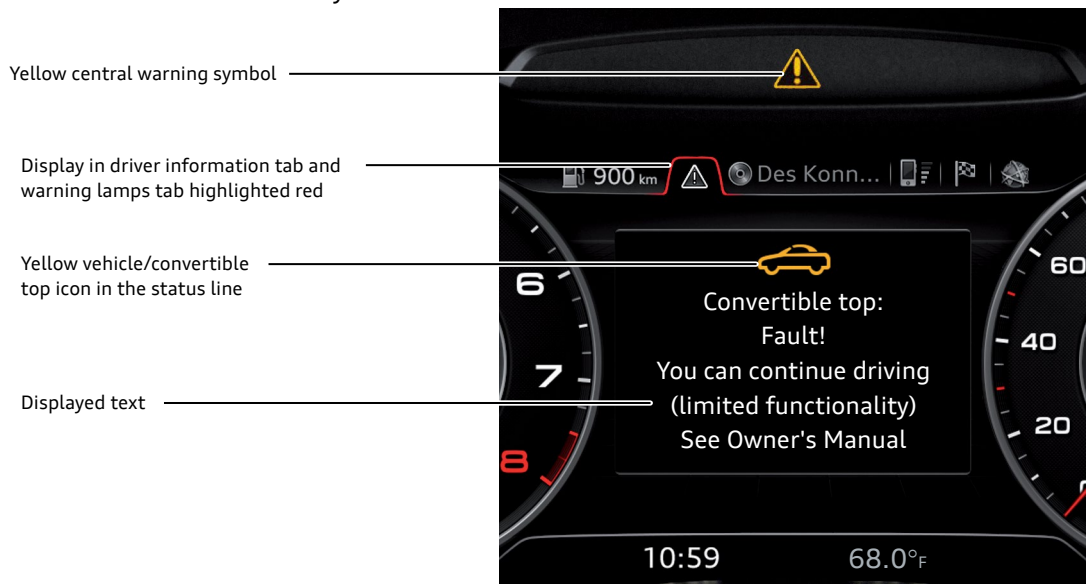

631_039

Message displays

Other reasons why the convertible top cannot be operated are displayed as messages.

- ▶ When messages about the convertible top are displayed, the yellow central warning lamp is **not** activated.
- ▶ When these messages are displayed, the vehicle/convertible top icon appears in the status line.
- ▶ Message texts are **not** included in the driver information and warning lamps tab.

If the convertible top is in an end position (open or closed) and a convertible top operating cycle is initiated in the same direction as the limit stop, "no" actions are initiated and no messages are displayed.

This message is displayed if the top is in an end position (open or closed) and the Power Top Operation Switch is actuated at a speed higher than 32 mph (50 km/h). In this situation, a top operating cycle is not initiated.



631_038

This message is displayed in the following situations:

- ▶ If a convertible top operating cycle is active and the vehicle speed increases to 34 mph (55 km/h). In this case, the operating cycle is stopped.
- ▶ **Or:** If a convertible top operating cycle is active, the vehicle speed increases to 34 mph (55 km/h) and the convertible top still moves into its limit position. For a list of conditions under which the convertible top still moves into its limit position at 34 mph (55 km/h) or higher (refer to page 27).
- ▶ **Or:** If a convertible top operating cycle was active or discontinued (Power Top Operation Switch was released) and the convertible top is in an intermediate position. The vehicle speed subsequently increases to at least 31 mph (50 km/h) and the switch is actuated again. In this case, the convertible top operating cycle is not resumed.



631_038

This message is displayed if the Power Top Operation Switch is actuated to open the top and the ambient temperature is below 5 °F (-15 °C). However, the convertible top can be closed when the ambient temperature is below 5 °F (-15 °C).



631_037

This message is displayed if a DTC fault code is present which prevents the operation of the top.



631_036

This message is displayed if the Power Top Operation Switch has been actuated with the ignition on (engine not running) and the battery voltage is too low. After starting the engine, the top can be operated again.



631_036

This message is displayed if the circuit breaker (thermal protection) is active when the Power Top Operation Switch is actuated.



631_036

This message is displayed if there is a static DTC fault code in the Convertible Top Control Module fault memory and a limit position (open or closed) has been reached when the Power Top Operation Switch is released.

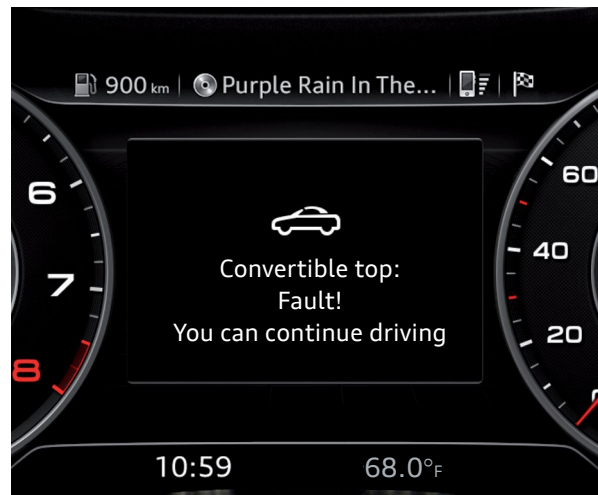

631_036

Convertible top opening sequence

To be able to open the convertible top, the following conditions must be met:

- ▶ The vehicle must be travelling slower than 31 mph (50 km/h).
- ▶ The ignition must be on.
- ▶ The ambient temperature must be above 5 °F (-15 °C).
- ▶ The battery must have sufficient voltage.

Initial situation: the convertible top is closed

Starting the opening cycle

If all conditions have been met, the opening cycle is initiated by lifting the Power Top Operation Switch continuously until the cycle is completed.

If the vehicle is travelling at a speed between 4 - 31 mph (6 - 50 km/h) the opening cycle can be started by lifting the Power Top Operation Switch briefly (less than 0.5 seconds) and releasing.



631_008

Power Top Operation Switch

First, the side windows open a pre-set distance.



631_023

Display in the Audi virtual cockpit

A display then appears showing the vehicle/convertible top icon and a curved arrow. The arrow tip is pointing backwards.

If the rear window heater is on, it is switched off. The rear window heater can only be switched on if the top is fully closed.

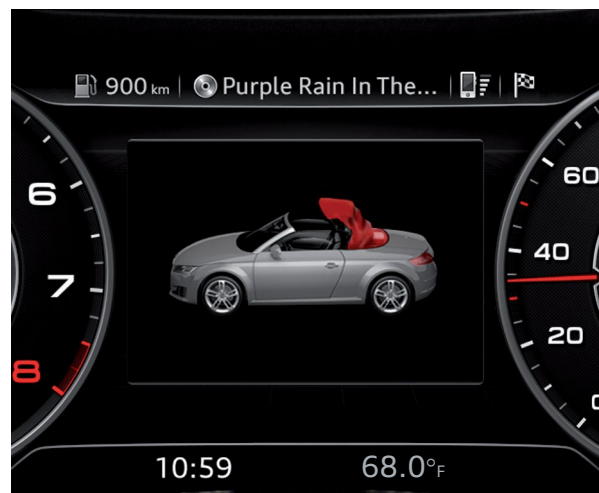

631_032

Convertible top opening

Next, the catch hook in the upper part of the lock in the window frame area moves upwards. Then the top moves back.



631_024

During this movement, the catch hook closes again. Both the left and right convertible top flaps (actuated by Bowden cables) close when the top is nearly stowed. The top folds completely into the top box.



631_025

Finally, the side windows close completely.



631_026

Display in the Audi virtual cockpit

An audible signal as well as a display indicate that the top operating cycle is complete and the convertible top is fully open.

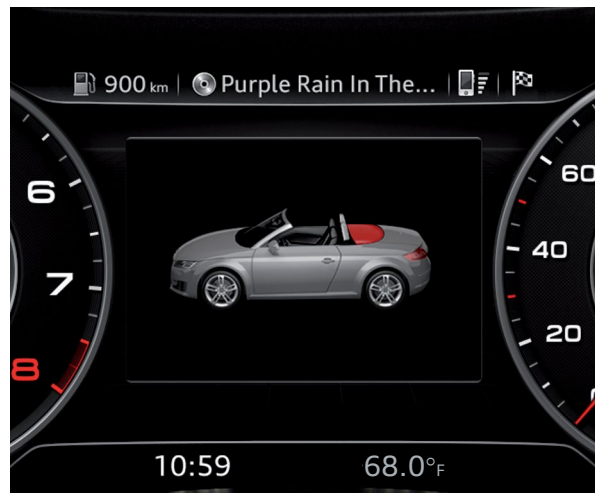

631_035

Convertible top closing sequence

To be able to close the convertible top, the following conditions must be met:

- ▶ The vehicle must be travelling slower than 31 mph (50 km/h).
- ▶ The ignition must be on.
- ▶ The battery must have sufficient voltage.

Initial situation: the convertible top is open

Starting the closing cycle

If all conditions have been met, the closing cycle is initiated by pressing the Power Top Operation Switch continuously until the cycle is completed.

If the vehicle is travelling at a speed between 4 - 31 mph (6 - 50 km/h) the closing cycle can be started by pressing the Power Top Operation Switch briefly (less than 0.5 seconds) and releasing.



631_009

Power Top Operation Switch

First, the side windows open a pre-set distance.

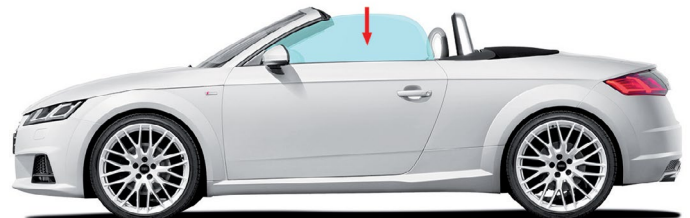

631_027

Display in the Audi virtual cockpit

A display then appears showing the vehicle/convertible top icon and a curved arrow. The arrow tip is pointing forward.

When an automatic top operating cycle is in progress (the vehicle is moving), an "A" is displayed at the start of the arrow.

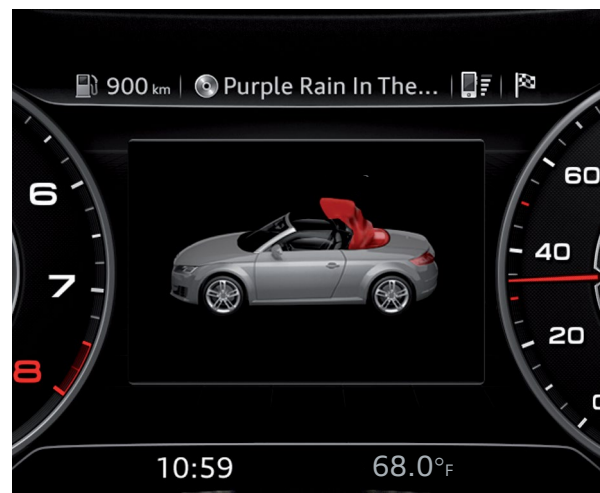

631_040

Convertible top closing

The convertible top is lifted out of the convertible top box and, at the same time, the convertible top flap covers on the left and right are opened mechanically by Bowden cables.



631_028

The catch hook moves upwards (1) and the top continues to close until it is in proximity to the windscreen frame. The catch hook closes (2), pulling the top onto the windshield frame, and locks the top in place.

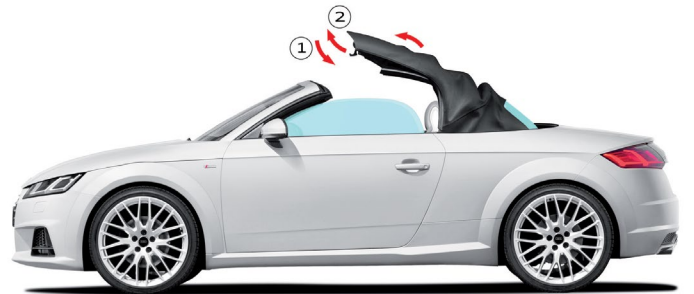

631_029

Display in the Audi virtual cockpit

An audible signal as well as a display indicate that the top operating cycle is complete and the top is fully closed.

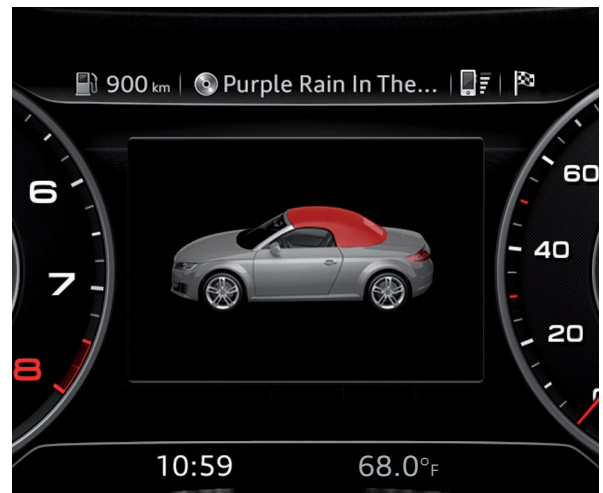

631_034

Operating the convertible top with the car key via the lock cylinder on the driver's door

The convertible top can be opened or closed via the driver's door locking cylinder.

This can be done using the integrated emergency key or the so-called wallet key.

Opening

To open the convertible top, the following conditions must be met:

- ▶ The vehicle must not be moving.
- ▶ The battery must have sufficient voltage.
- ▶ The ambient temperature must be above 5 °F (-15 °C).

To open the convertible top, first unlock the vehicle with the car key. Then insert the car key into the lock cylinder on the driver's door and turn it in the "open" direction (1).

If the car key is now turned in the "open" direction again within 2 seconds and held in this position (2.), the convertible top operating cycle will start. The car key must be kept held in the "open" position while the convertible top operating cycle is in progress. When the car key is released, the convertible top operating cycle stops instantaneously. To resume the convertible top opening cycle, the car key must again be turned in the "open" direction and held in this position. If the car key is turned in the "close" direction and held in this position, the convertible top will close again.

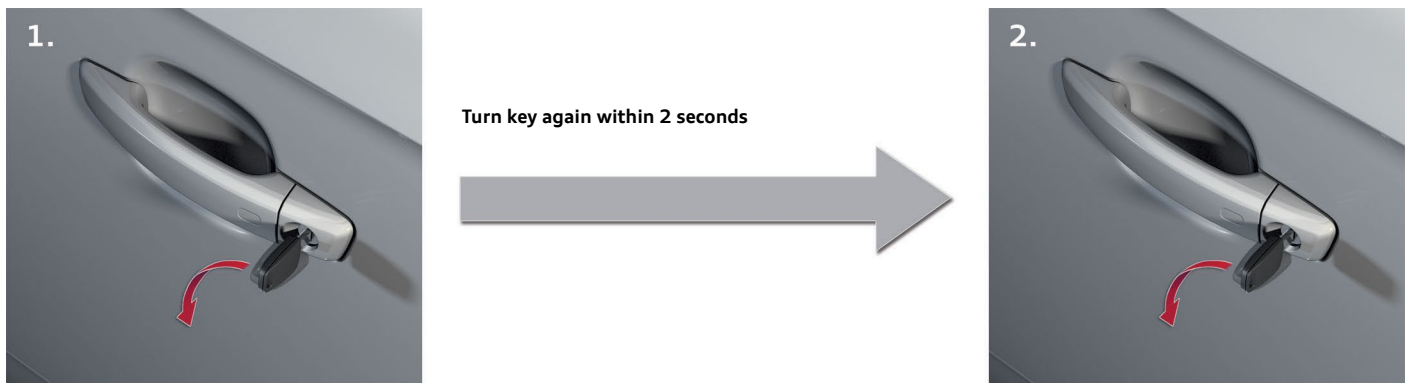

631_042

Closing

To close the convertible top, the following conditions must be met:

- ▶ The vehicle must not be moving.
- ▶ The battery must have sufficient voltage.

Insert the car key into the lock cylinder on the driver's door and turn it in the "close" direction (1). If the car key is now turned in the "close" direction again within 2 seconds and held in this position (2), the convertible top operating cycle will start.

The car key must be kept held in the "close" position while the convertible top operating cycle is in progress. When the car key is released, the convertible top operating cycle stops instantaneously.

To resume the convertible top operating cycle, the car key must again be turned in the "close" direction and held in this position.

If the car key is turned in the "open" direction and held in this position, the convertible top will open again.

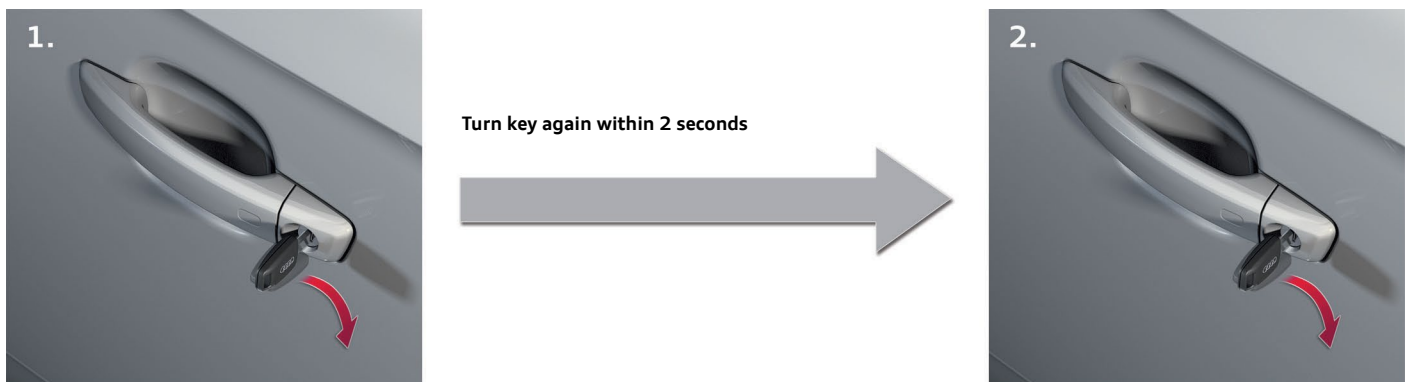

631_041



Note

When actuating a top opening or closing cycle using the vehicle key, there may be a delay between key movement and the top beginning to move.

Operating the convertible top while driving

The top can be opened while the vehicle is moving up to a speed of 31 mph (50 km/h).

If the vehicle speed rises to 34 mph (55 km/h) while a top operating cycle is in progress, the cycle will normally stop and the driver is alerted by audible and visual warnings. There are exceptions to this.



631_058

Convertible top operating cycle at high speed

If the vehicle speed rises to 34 mph (55 km/h) while a top operating cycle is in progress, the top behaves differently when opening or closing.



631_038



631_038

Opening

If the top is opening and the vehicle speed increases to 34 mph (55 km/h) or higher, the operating cycle is not interrupted. The top opens fully.

Closing

If the top is closing and the vehicle speed increases to 34 mph (55 km/h) the operating cycle is interrupted. The top stops in its current position. The operating cycle cannot be restarted until the vehicle speed drops to below 31 (50 km/h).

Wind deflector

The wind deflector reduces air turbulence in the passenger compartment and thus enhances ride comfort.

It can be manually retracted and extended (by continuously pushing or pulling the switch) and retracted in automatic mode (by briefly touching the switch).



631_010

Operation

The wind deflector is controlled by the Convertible Wind Deflector Switch. It can only be extended or retracted if the convertible top is fully open.

If the wind deflector is extended when the top is closed, it will automatically retract. This allows “one touch” operation with the Power Top Operation Switch when closing the top.



631_012

Power Top Operation Switch

Convertible Wind Deflector Switch

Emergency operation of convertible top

In the event of a malfunction, the convertible top can be closed manually.

Closing the convertible top

During all stages of the emergency closing DO NOT reach into the top linkage or other moving parts. There is a risk of severe injury. When ever possible, the emergency closing procedure should be done by two people.

Tools required

All tools necessary to perform the emergency closing procedure are located in the vehicle tool kit.

Conditions:

- ▶ The parking brake must be applied.
- ▶ All side windows are lowered.
- ▶ The function is deactivated.

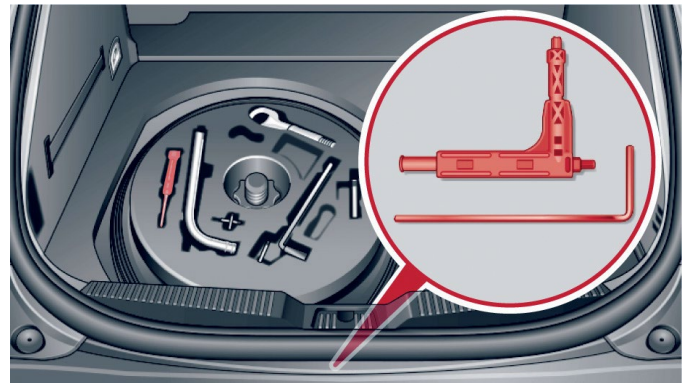

631_014

1. Separate push rod from ball head in direction of arrow

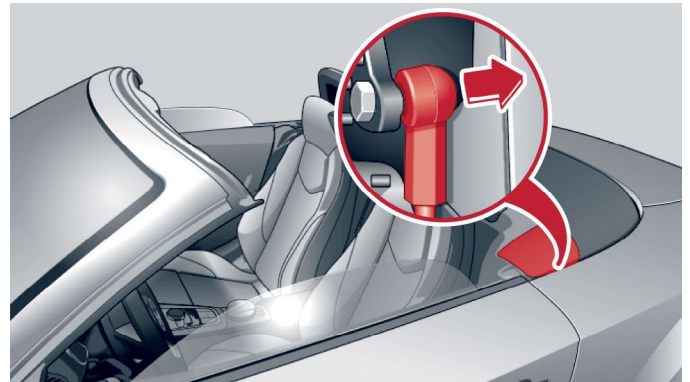

631_015

2. Raise convertible top flaps

Raise the convertible top flaps and stow the push rod in the designated recess. Repeat both procedures on the other side of the vehicle.

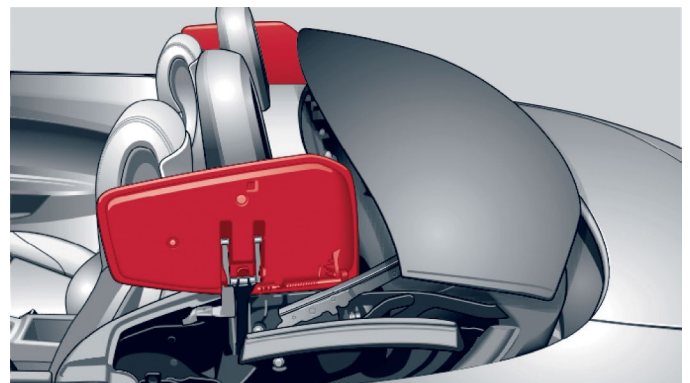

631_016



Note

During the entire duration of emergency operation make sure that both covers are fully open and that the push rods have been stowed in the recess, in order to avoid causing damage when raising the convertible top.

3. Undo bolts

Remove the bolt using the hexagon socket wrench from the tool kit by turning it fully in the direction of the arrow. Repeat the procedure on the other side.

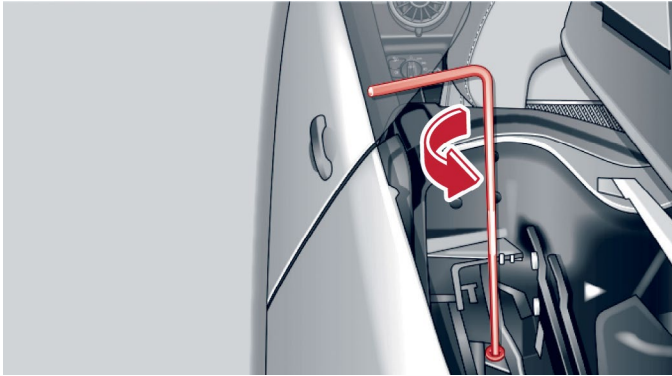

631_017

4. Lift out the convertible top

Lift the convertible top out of the convertible top compartment, if possible with the aid of a second person, and pull it out completely.

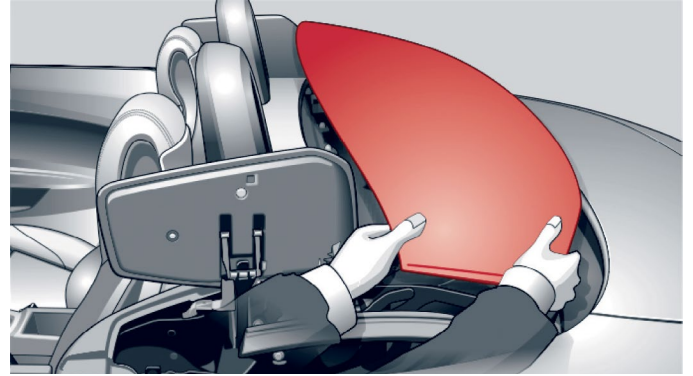

631_018

5. Place the convertible top on the window frame

Push the convertible top in the direction of the arrow onto the windshield frame.

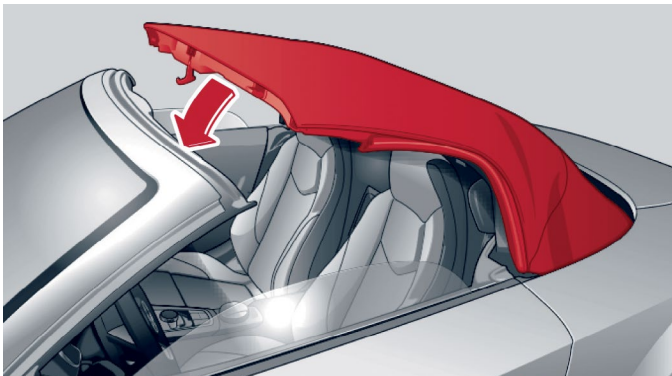

631_019

6. Remove cover

Remove the cover at the center of the convertible top using the screwdriver from the tool kit.

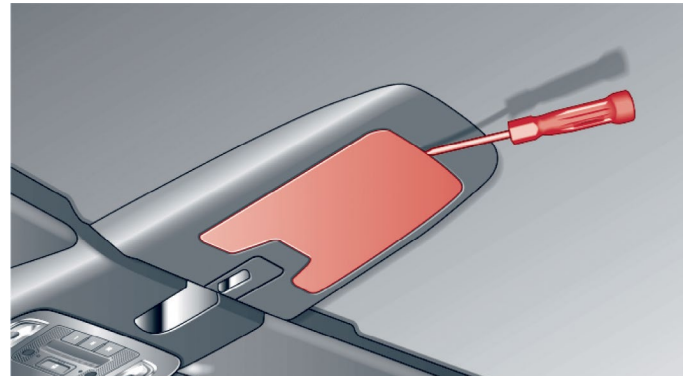

631_020

7. Lock the convertible top

Insert the crank from the tool kit fully into the socket of the Convertible Top Lock Motor.

Pull the convertible top down at the side until it is fully seated on the window frame. Turn the crank in the direction of the arrow (clockwise) until the convertible top is fully locked. Then remove the crank.

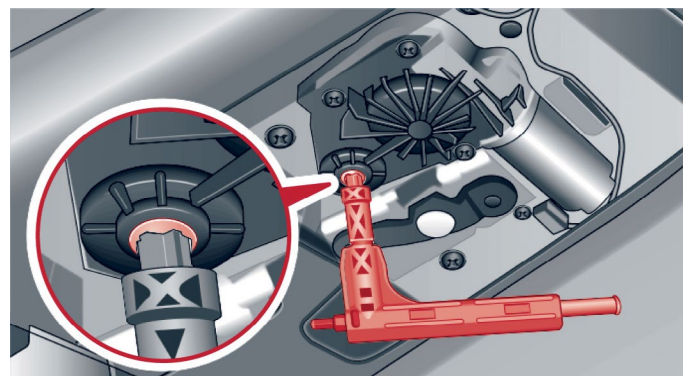

631_021



Note

During all stages of emergency convertible top operation, there is a risk of trapping hands or causing injury to other persons.



Reference

Please refer to the Owner's Manual for further information on emergency operation.

Passive safety

Components

Depending on country version and trim level, the passive occupant system in the Audi TT Roadster can have the following components and systems:

- ▶ Airbag Control Module.
- ▶ Driver airbag.
- ▶ Front passenger airbag.
- ▶ Front side airbags. (head-thorax airbag)
- ▶ Knee airbag, driver and front passenger sides.
- ▶ Front airbag crash sensors.
- ▶ Front crash sensors for side crash detection. (pressure sensors)
- ▶ Rear crash sensor for side crash detection. (acceleration sensor)
- ▶ Front inertia-reel seat belts with pyrotechnic belt pretensioners.
- ▶ Front inertia-reel seat belts with active belt force limiters.
- ▶ Seat belt warning for all seats.
- ▶ Seat belt switches on all seats in the seat belt buckles.
- ▶ Seat occupancy sensor in front passenger seat.
- ▶ Airbag disabling switch, front passenger side.
- ▶ Front passenger airbag **OFF** and **ON** warning lamps.
- ▶ Driver and front passenger seat position sensors.
- ▶ Battery interrupter.

Side airbags (head-thorax airbags)

The side airbags are configured as head-thorax airbags.

The head-thorax airbags are designed to help protect not only the body, but also the head of the front occupants. By integrating the side airbags in the front seat backs, the airbags are positioned in proximity to the front occupants irrespective of the seat position.

Rollover protection system

The Audi TT Roadster comes equipped with rigid rollover bars behind the rear seats.

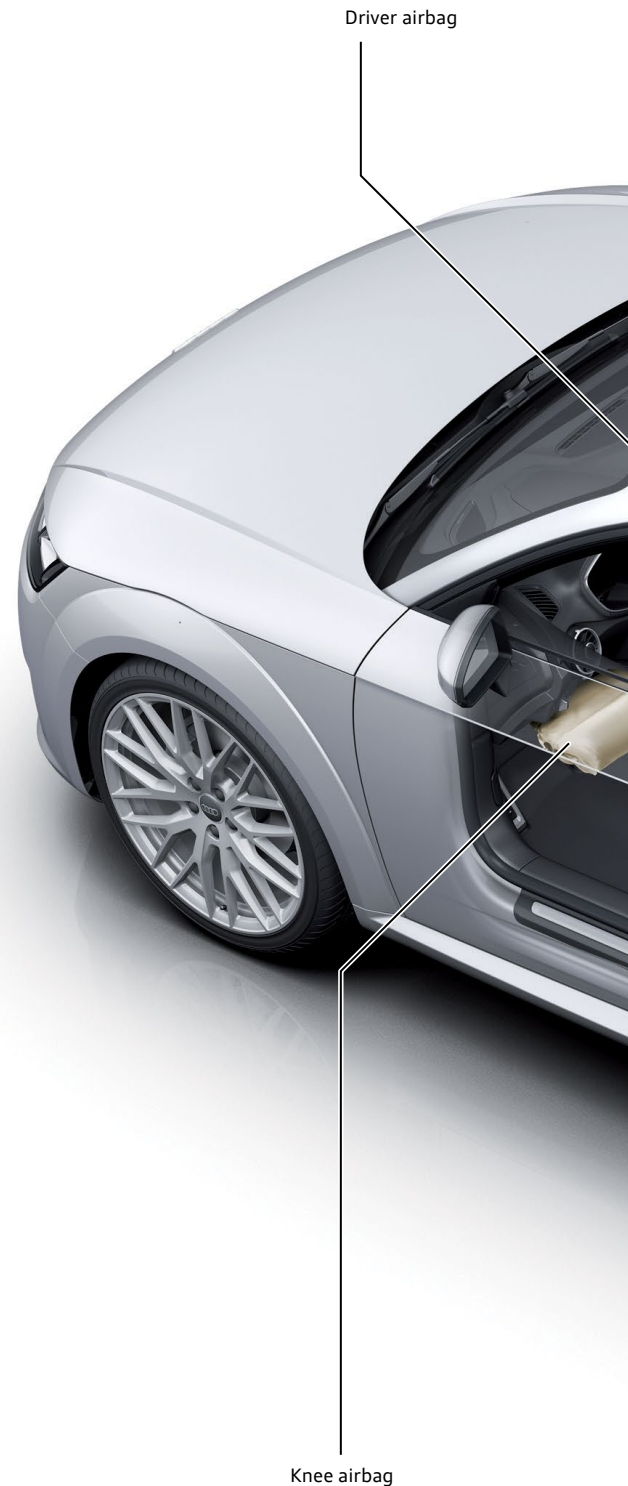



Front passenger airbag

Knee airbag

Side airbag
(head-thorax airbag)

Side airbag
(head-thorax airbag)

Engine and power transmission

Engine

2.0l TFSI engine (CHHC)
169 kW



6-speed
quattro double-
clutch transmission
S tronic

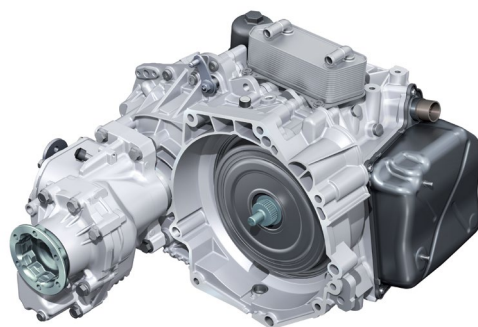

Rear axle drive
5th generation
Haldex coupling

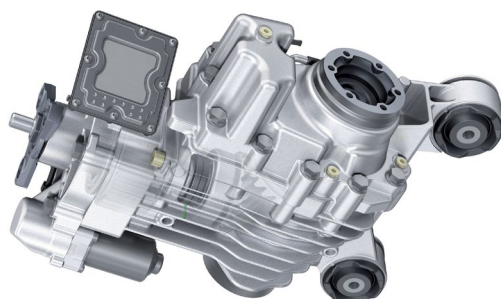

Chassis



631_092

The chassis of the Audi TT Roadster is based on that of the Audi TT Coupe. To meet requirements with regard to static and dynamic body rigidity, special diagonal struts have been integrated into the front and rear axles).

In addition, the rear axle sub-frame is rigidly bolted to the body in quattro models. For visual differentiation, the TT Roadster comes with a wider range of wheels than the TT Coupe.

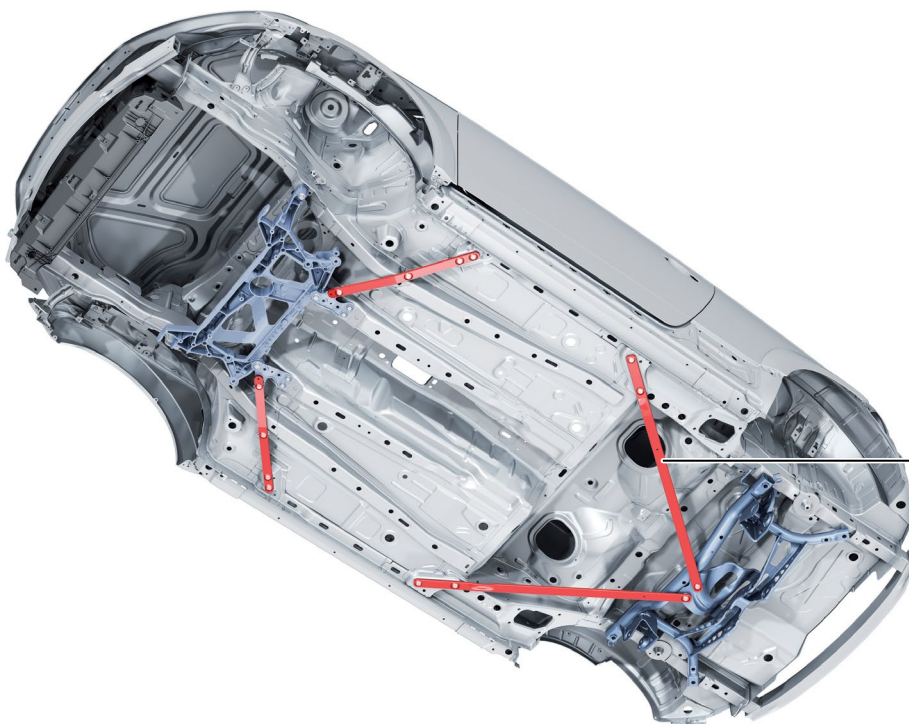

Diagonal struts

631_091

Seat belt microphone

Designation	Seat Belt Microphone Control Module
Equipment	
Installation location	Under the center console
Function	Select the best microphone signal and relay the signals to Information Electronics Control Module 1
Address Word	A6 - microphone control unit
Data bus communication	Infotainment CAN bus user



631_083

Seat Belt Microphone Control Module

For optimal speech communication quality, the Audi TT Roadster is equipped with three microphones. One microphone is located in the overhead module, and one microphone in each of the front seat belts. Three microphone capsules are integrated in each seat belt.

Seat Belt Microphone Control Module always selects the best microphone signal and relays it via discreet wiring to the Information Electronics Control Module.

The Seat Belt Microphone Control Module receives information via the CAN buses to determine whether the driver or front passenger seat belt is inserted into the buckle and whether the front passenger airbag has been deactivated using the key switch. The CAN connection is also used for diagnostics.

The information received by the Seat Belt Microphone Control Module can result in the following scenarios (refer to table):

Driver's seat belt buckle	<ul style="list-style-type: none"> ▶ Seat belt "inserted" into buckle = seat belt microphone active. ▶ Seat belt "not inserted" into buckle = microphone in overhead microphone active.
Front passenger's seat belt buckle	<ul style="list-style-type: none"> ▶ Seat belt "inserted" into buckle and front passenger airbag active = driver and front passenger microphone active / signal selection (best signal) through both seat belt microphones. ▶ Seat belt "inserted" into buckle and front passenger airbag deactivated = only with active driver's seat belt microphone (interpretation: child seat). ▶ Seat belt "not inserted" into buckle = only driver microphone active.

Climate control

Introduction

The climate control system of the Audi TT Roadster is based on that of the Audi TT Coupe.

The maintenance and repair operations for the climate control system are also identical to those of the Audi TT Coupe.

The following components and equipment are identical in the Audi TT Coupe and the Audi TT Roadster:

- ▶ Heater and air conditioner.
- ▶ Condensed water drain.
- ▶ Forced ventilation of the cabin.
- ▶ Dust and pollen filter.
- ▶ The air conditioning system is operated by controls integrated in the 5 outlets.

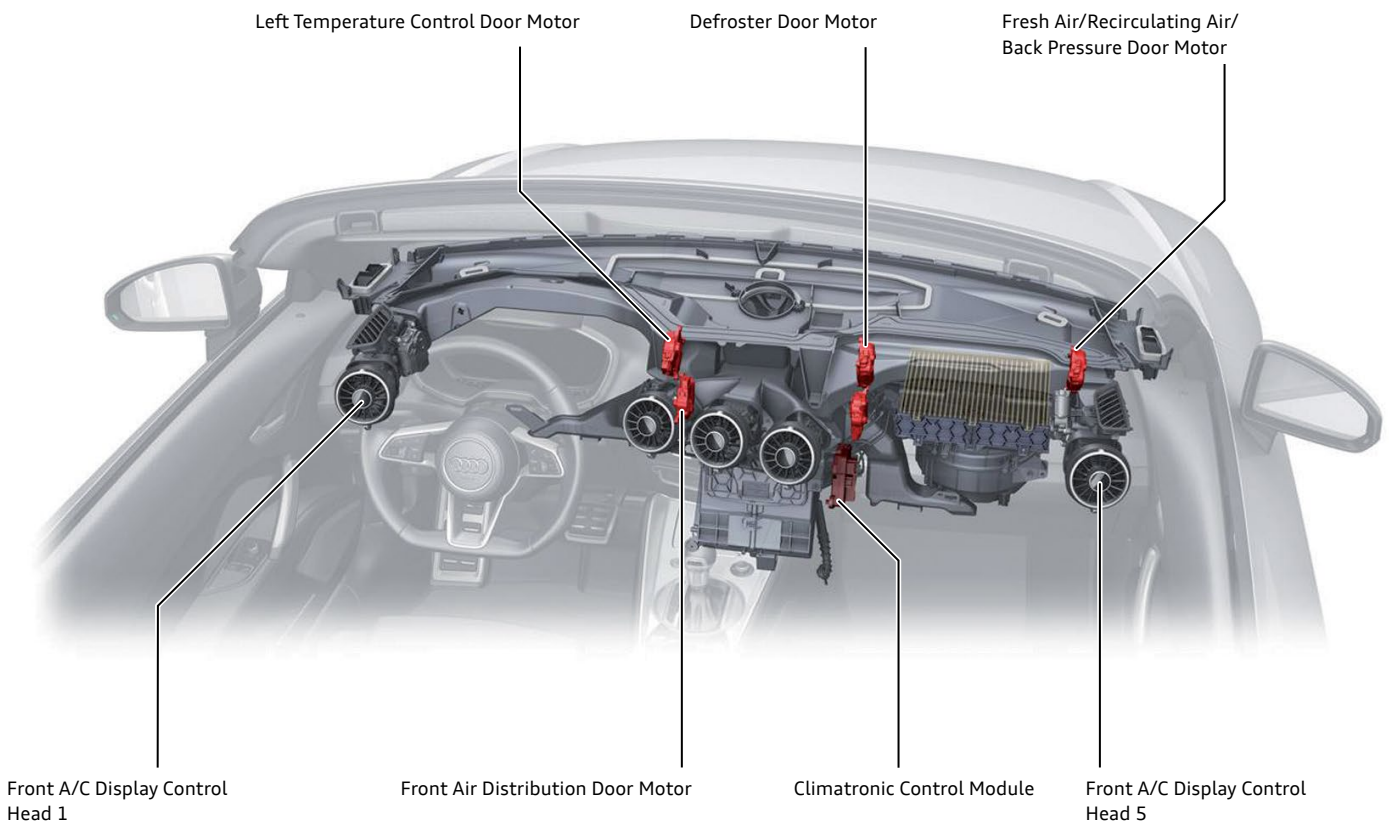

631_086



Reference

For more information about the air conditioning system, refer to eSelf-Study Program [600276, The 2016 Audi TT Introduction Sales and After Sales.](#)

Seat systems

The following sport seats are available for the Audi TT Roadster:

- ▶ Basic sport seat, manually adjustable.
- ▶ Optional multicontour S sport seat with integrated head restraint and electrical lumbar support.
- ▶ Optional multicontour S sport seat with pneumatic back rest adjustment and pneumatic lumbar support.

The multicontour S sport seats are optionally available with head area heaters.

Design of the multicontour S sport seat with head area heater



Head area heater

The head area heater is optionally available for the seat heater in the Audi TT Roadster.

Vehicles with the head area heaters also have operating controls and display icons integrated in Front A/C Display Control Head 1 and Front A/C Display Control Head 5. Pushing the control operates the seat heater, turning controls the head area heater (refer to the arrows).



631_088

Outlet

Vehicles with head area heaters can also be identified by the outlets on the seat back in the neck region. Head Area Heater Control Modules are integrated on the sides of the seat backs of their respective seats.

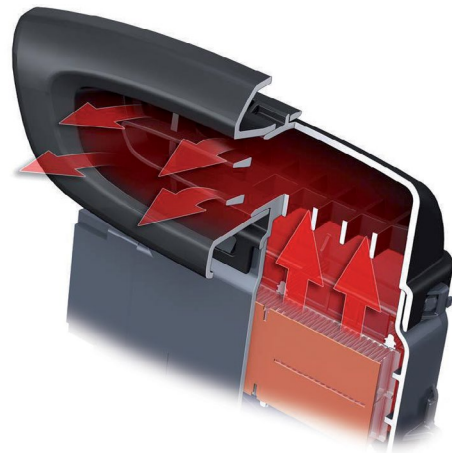

631_089

Service

Inspection and maintenance

The Audi TT is subject to fixed inspection and maintenance intervals in the USA.

The value indicated for the next oil change is 5,000 miles / 365 days for new vehicles. The next oil change after this is fixed at 10,000 miles / 365 days.

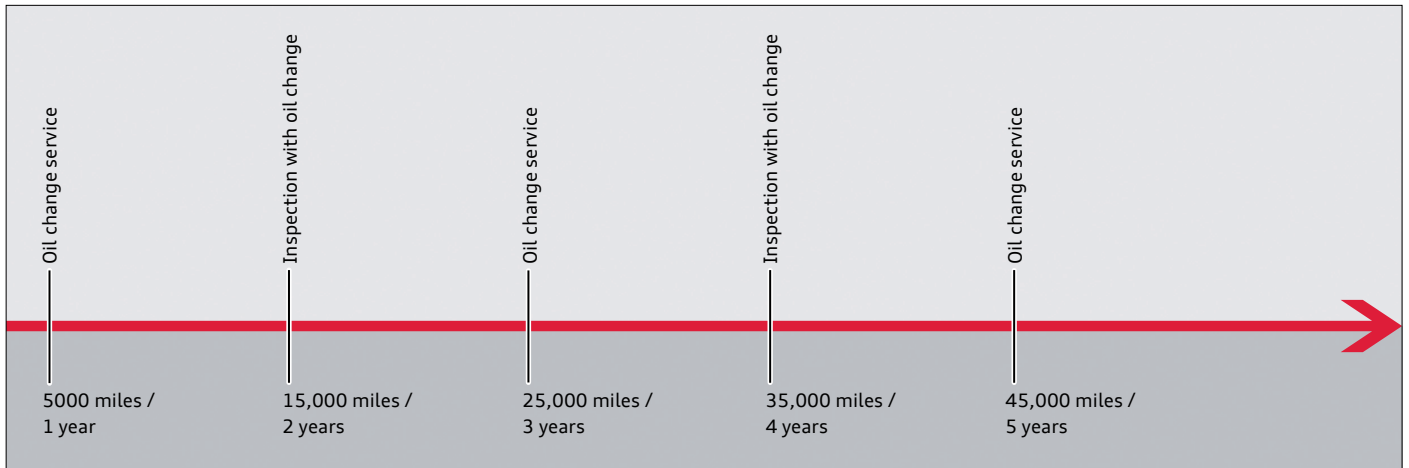

630_023

2.0l TFSI

Oil change	According to service interval display, between 15,000 km / 1 year and 30,000 km / 2 years depending on driving style and conditions of use.
Inspection	30,000 km / 2 years
Pollen filter change interval	60,000 km / 2 years
Air filter change interval	90,000 km
Brake fluid change interval	Change after 3, 5, ... years
Spark plug change interval	60,000 km / 6 years
Fuel filter change interval	-
Timing gear	Chain (lifetime)
Gear oil change interval ¹⁾	60,000 km

¹⁾ S tronic



Note

Always consult ElsaPro for the latest information about maintenance schedules and service procedures.



Note

Always check the Fluid Capacity Chart in ServiceNet for the correct oil specification and fluid level before changing oil. Always use special tool T40178 when measuring the engine oil level.

Notes

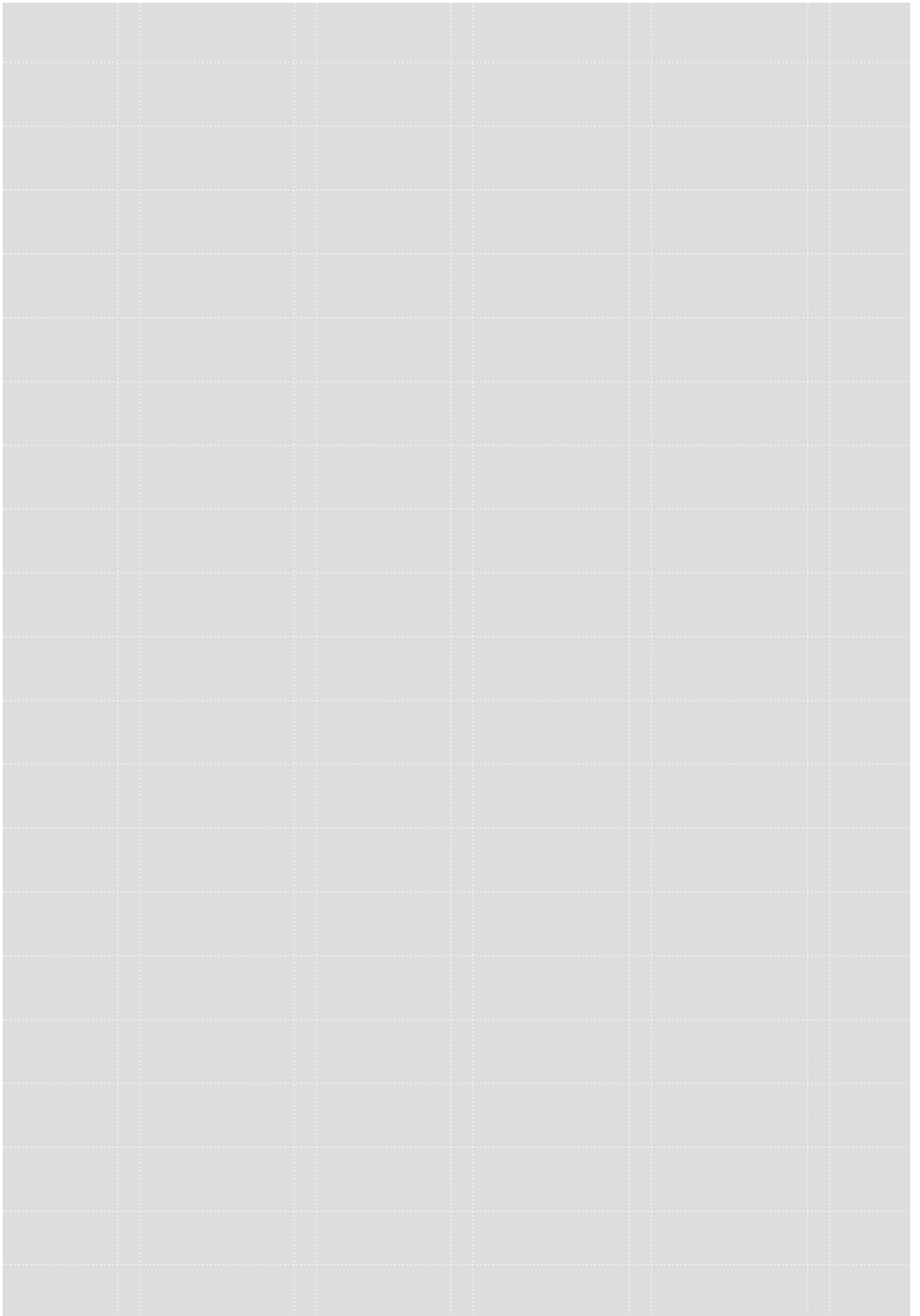

Self study programs

For more information about the technology of the Audi TT Roadster, please refer to the following self study programs.

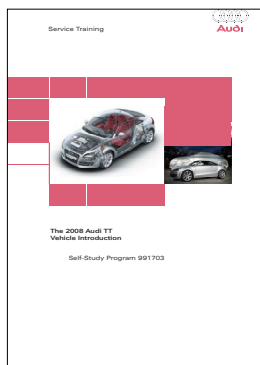

[991703](#)
[The 2008 Audi TT Vehicle Introduction](#)

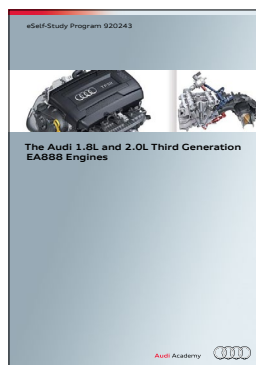

[920243](#)
[The Audi 1.8L and 2.0L Third Generation EA888 Engines](#)

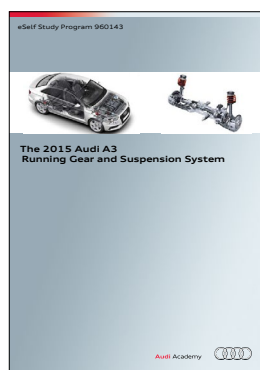

[960143](#)
[The 2015 Audi A3 Running Gear and Suspension System](#)

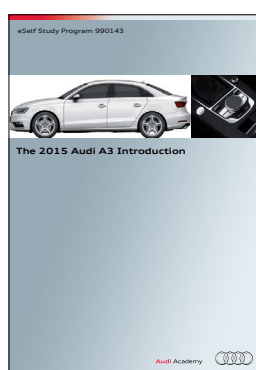

[990143](#)
[The 2015 Audi A3 Introduction](#)



[600277](#)
[Audi Virtual Cockpit & Infotainment Systems Sales and After Sales](#)

Knowledge assessment

An On-Line Knowledge Assessment (exam) is Available for this eSelf-Study Program.

The Knowledge Assessment is required for Certification credit.

You can find this Knowledge Assessment at:

www.accessaudi.com

From the accessaudi.com Homepage:

- ▶ Click on the “ACADEMY” tab
- ▶ Click on the “Academy site” link
- ▶ Click on the Course Catalog Search and select “600275 - The 2016 Audi TT Roadster Sales and After Sales”

Please submit any questions or inquiries via the Academy CRC Online Support Form which is located under the “Support” tab or the “Contact Us” tab of the Academy CRC.

Thank you for reading this eSelf-Study Program and taking the assessment.

All rights reserved.
Technical specifications are
subject to change without notice.

Audi of America, LLC
2200 Ferdinand Porsche Drive
Herndon, VA 20171