

Engine Injector and Sleeve, Cleaning
(Conical)
VN, VHD, VAH

SP 237-001, Engine Injector and Sleeve, Cleaning (Conical)

(June 2017)

Certain VOLVO VN, VHD, and VAH trucks built from 05/16/2015 to 09/09/2016 and equipped with HDE13 engines have been identified as high risk for injector sleeve combustion gas leakage due to excessive graphite paste application during assembly, possibly resulting in loss clamp load.

Required Parts

Engine Injector and Sleeve, Cleaning (Conical) Parts			
Item #	Description	Part Number	Qty
1	Flange Screw, Injector Yoke	8192804	6
2	Injector Sleeve	85137065	6
3	O-ring Kit, Injector	276948	6
4	Sealing Ring, VOLVO Engine Brake (VEB)	1677370	2
5	V-clamp, Exhaust Gas Recirculation (EGR), Venturi	20504408	1
6	Sealing Ring, Crank Case Ventilation (CCV)	21532258	1
7	O-ring, Exhaust Gas Recirculation (EGR), Venturi	967343	2
8	Sealing Ring, VOLVO Engine Brake (VEB)	20526428	1

Engine Injector and Sleeve, Cleaning (Conical) Procedure

You must read and understand the precautions and guidelines in Service Information, group 20, "General Safety Practices, Engines" before performing this procedure. If you are not properly trained and certified in this procedure, ask your supervisor for training before you perform it.

DANGER

Do not attempt to repair or service this vehicle without having sufficient training, the correct service literature and the proper tools. Failure to follow this could make the vehicle unsafe and lead to serious personal injury or death.

- 1 Park the vehicle on a level surface.
- 2 Apply the parking brake.
- 3 Place the transmission in neutral or park.
- 4 Install the wheel chocks.

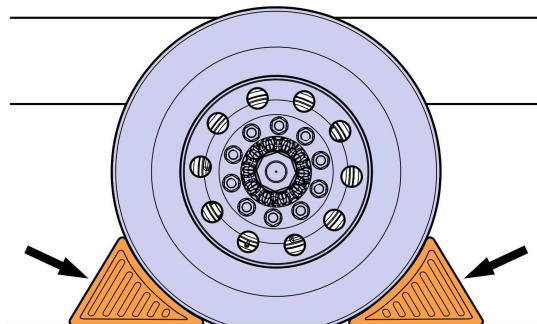

- 5 Disconnect the cable from the battery's negative terminal.

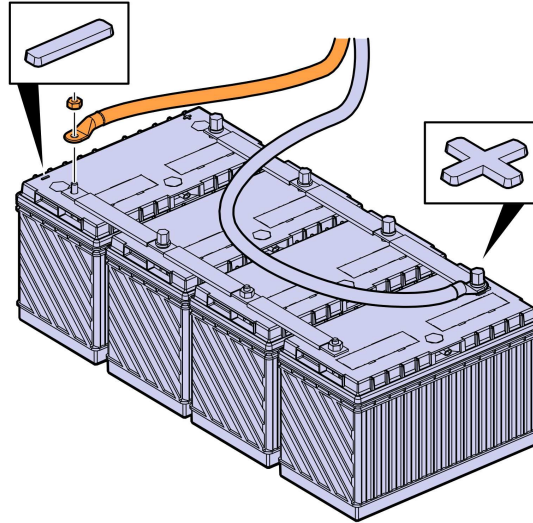

W3086747

- 6 Remove and clean injectors and cups, reinstall injectors with new cups using the latest published repair method from Impact (2379-03-02-01) or (PV776-89311434).

If during the campaign repair a combustion gas leaking injector(s) is replaced you need to do the following for claim submission:

File the campaign claim in UCHP as you normally would, then add a second line as a warranty claim job for the injector replacement. This line will be only for the injector(s) and labor to program the trim code. You will need to use labor code 1700-08-03-39 with 0.3 hrs for the trim code programming.

Note: VOLVO will not approve replacement of complete injector sets.

- 7 Connect the cable to the battery's negative terminal.

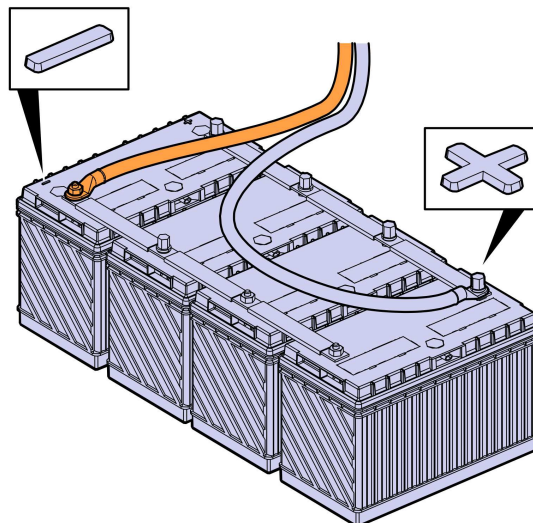

W3086758

8 Remove the wheel chocks.

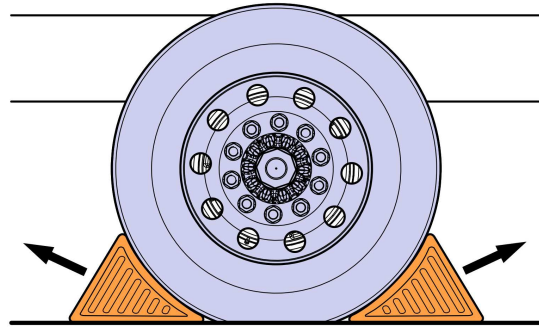

W7086759

Reimbursement

This repair is covered by an authorized Service Program. Reimbursement is obtained via the normal claim handling process.	UCHP Reimbursement
Recall Status	
Vehicle inspected, repair not required	1- Inspected OK
Vehicle repaired per instruction	2- Modified per instruction
Labor Code	
Primary Labor Code – Engine Injector and Sleeve, Cleaning (Conical)	2379-03-02-07 6.1 hrs.
Labor Code – Road Test	1700-20-09-01 0.2 hrs
Labor Code – Steam Clean	1700-11-03-03 0.2 hrs
Time to take charge and determine campaign status	1700-16-01-01 0.3 hrs
Causal Part	22479124
SCC Code	S7186
Authorization Number	N/A
Expiration Date	30-JUN-2018

Note: Take Charge Time is not included in the Labor Code for this operation. Take charge may be eligible but can only be used once per repair visit. If vehicle is having other warranty repairs performed, take charge should be charged to the warranty repair, otherwise take charge can be charged to this service program.