



# Technical Bulletin

| Model(s)                 | Year      | Eng. Code | Trans. Code | VIN Range From | VIN Range To |
|--------------------------|-----------|-----------|-------------|----------------|--------------|
| Golf/GTI,Golf SportWagen | 2015-2016 | All       | All         | All            | All          |

## Condition

**87 15 18** December 16, 2015 **2038368** Supersedes Technical Bulletin V871517 dated November 24, 2015 to update the vehicle model years applicable and to add N280 valve inspection R.O. documentation.

### Air Conditioning Does Not Cool and or Compressor is Noisy

One or more of the following conditions are exhibited:

- The air conditioning does not cool, or the cooling performance is very weak.
- The air conditioning system cools, but the compressor is noisy. The noise is characterized as a grinding or groaning noise.
- Either symptom may be intermittent.
- No DTCs are stored.

## Technical Background

The condition may be caused by a faulty A/C compressor regulator valve N280 (Sanden). The internal components of the valve can be obstructed and incapable of full function. This loss of refrigerant regulation from N280 can cause noise from the air conditioning compressor and/or affect the HVAC cooling.



**Figure 1** N280 Refrigerant Regulating Valve  
5Q0260839A

The condition may be caused by a faulty N280 valve (Figure 1). The internal components of the valve can be obstructed and incapable of full function. This loss of refrigerant regulation from N280 can cause noise from the A/C compressor and/or affect the HVAC cooling.



# Technical Bulletin

---

## Note:

This bulletin applies to vehicle built with Sanden 5Q0820803C, 5Q0820803E and 5Q0820803G compressors only. The replacement N280 valve is not compatible with other Sanden compressors. The N280 valve is not compatible with any Denso compressors.

**If a Denso compressor is installed on the vehicle this bulletin does not apply. Further diagnosis is required.**

## Production Solution

Improved N280 valve for the Sanden A/C compressor CW36/15.

## Service

Since either symptom may be intermittent, the diagnostic process can affect the reproducibility of the condition. Begin the diagnosis by isolating the cause before performing the basic checks.



Connect both the refrigerant service station (Figure 4) and the diagnostic tester to the vehicle.

**Figure 4.** Robinair A/C Service Unit.

### Cases of noise:

When diagnosing cases of noise, use chassis ears or a technician's stethoscope to make sure that the root cause of the noise is from the air conditioning compressor. The noise can change or may be absent depending on the setting on the HVAC control unit. In many cases, the noise is more pronounced with the system switched OFF.



# Technical Bulletin

## Cases of low or no cooling performance:

Rule out a refrigerant circuit leak as the root cause. Evacuate the refrigerant circuit to determine the refrigerant volume. The refrigerant volume will likely be in specification. Should the refrigerant volume be too low, investigate a potential refrigerant leak in the circuit. It is not likely that the refrigerant level will be too high because if it is, a DTC will be stored. If no system leak is determined, recharge the circuit with the specified amount of refrigerant before proceeding.

## Perform the following diagnostic steps:

With the engine at idle, switch the climate control unit to full cold and full fan.

Turn recirculation mode on and close all windows.

Using the diagnostic tester, go to Guided Functions.



Monitor the measuring value for the air conditioner compressor regulating valve N280 signal (Figure 5).

The actual and specified values will be plausible and will show a normal regulating range of current for cooling request (0.400 A – 0.820 A).

**Figure 5.** Checking N280 signal value Measuring Value Block.



After verifying the compressor should be on and operating. Check the gauge readings on the Robinair service station to verify equalized pressure readings on the high and low sides of the circuit (no pressure generation from the compressor) (Figure 6).

**! Note: If the gauge readings are showing normal compressor operation per the Elsa Repair Manual, this bulletin does not apply and further diagnosis is required.**

**Figure 6.** Equalized pressure condition.



# Technical Bulletin

---



**Figure 7a.** Example of torque limiter over load protection activated.

Check that the compressor torque limiter has not been activated (Figure 7b).

**!** **Note: If the torque limiter has been released the N280 regulating valve is not at fault. The compressor needs to be replaced.**



**Figure 7b.** Example of torque limiter over load protection still intact.



# Technical Bulletin



Shut off the engine. Connect the breakout harness VAS 5256 (Figure 8) between the N280 valve and its connector.

**Figure 8.** VAS 5256 breakout harness.



Go to Operating Mode “Measurements” to check the N280 signal from the control module.

Select Measurements.

Select oscilloscope.

Change time division to 2ms/Div (Figure 9).

**Figure 9.** Select Measurements from operating mode menu”.



Select the correct DSO channel according the test leads hooked to the vehicle (Figure 10).

**Figure 10.** Setting up DSO channel”.



# Technical Bulletin

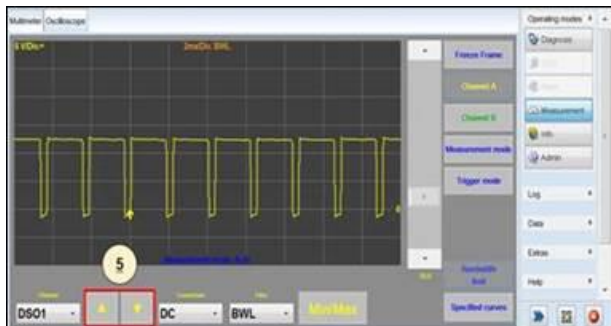

Figure 11. Checking the N280 signal wave form.

Change the voltage to 5V Div.

Check the signal wave form (Figure 11). The square wave signal should be between 75% and 100%.

If the wave form signal is good, the mechanical integrity of the N280 valve needs to be inspected.

**GO TO: Removing/Installing the N280 Regulating valve.**

## Removing/Installing the N280 Regulating valve.

Recover the refrigerant from the system. Remove the N280 valve using the following procedure.

### **WARNING:**

**With the refrigerant circuit charged the N280 valve is under pressure. Be certain that the refrigerant circuit is completely discharged before removing the N280 valve.**

**Remove one of the A/C lines from the compressor to assure the pressure in the compressor is the same as ambient pressure.**

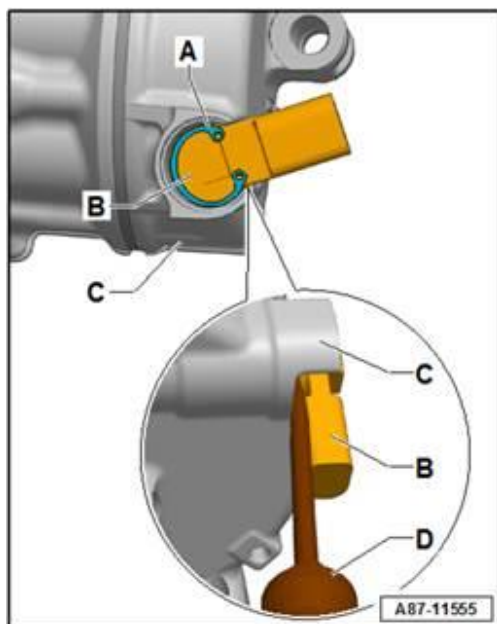

1. Remove circlip-A- carefully.

### **Note:**

**Circlip must be reused.**

2. Carefully remove the A/C Compressor Regulator Valve - N280- -B- from the A/C compressor mount -C-, using a suitable screwdriver -D-, for example (Figure 12).

Figure 12. Circlip / N280 removal



# Technical Bulletin

---



**Figure 13.** Corrosion in the N280 valve bore.

Assess the condition of the N280 valve bore and the valve filter screen (Figure 13). If severe contamination is found in valve bore there is a risk of damaging the replacement valve on installation. In these cases the A/C compressor must be replaced.

**⚠ Note:**

**A slight amount of debris or corrosion does not present a risk and does not justify replacement of the AC compressor.**



**Figure 14:** Severe contamination at the N280 valve filter screen.

Should severe contamination be found at the valve filter screen (Figure 14) and A/C compressor replacement becomes necessary, ensure that the refrigerant circuit is flushed in the course of repair.

**⚠ Note:**

**Small random particles on the filter screen does not constitute “severe” contamination and does not justify replacement of the A/C compressor.**

- If little or no corrosion or contamination is found perform Repair Procedure A: Replacing the N280 regulating valve.
- If corrosion and contamination is found, perform Repair Procedure B: A/C compressor replacement.
- **Document the all workshop findings of this procedure on the repair order.**



# Technical Bulletin

## Repair Procedure A: Replacing the N280 regulating valve

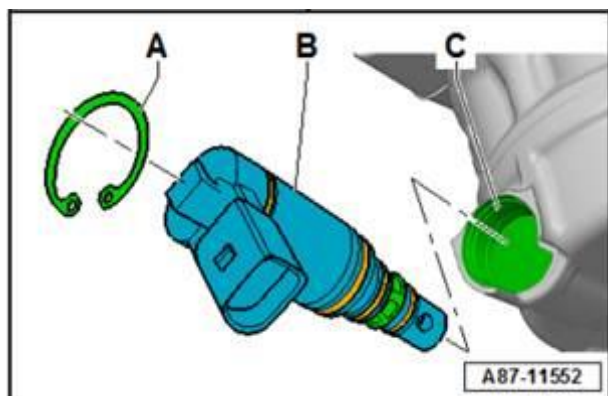

1. Check the A/C compressor mount -C- and the circlip groove for dirt, and if necessary, clean them carefully and thoroughly with a clean, lint-free cloth (Figure 15).

Figure 15: Prepare mount for N280 installation.

### Note:

Risk of damaging another N280 Valve or compressor may result due to dirt contamination or damage to the sealing surfaces in the mount.

- If necessary, carefully clean the A/C compressor mount -C- using only a clean, lint-free cloth (do not use compressed air).
- Make sure while cleaning the mount -C- that no dirt gets into the area underneath the O-ring sealing surface -F- or the existing channels and none of the mount sealing surfaces become damaged.

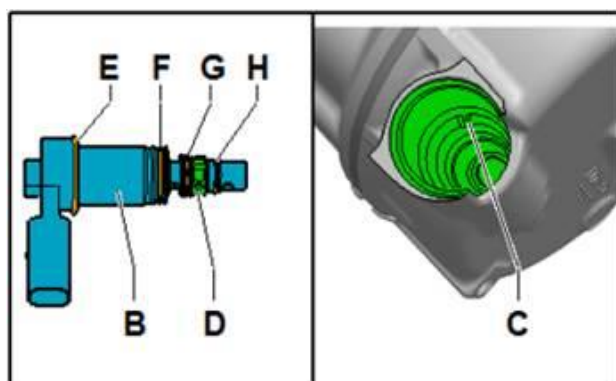

1. Check the O-rings -F-, -G-, -H- and -E- (if applicable) of the A/C Compressor Regulator Valve -N280- -B- for damage.
2. Coat the O-rings -F-, -G-, -H- and -E- (if applicable) of the A/C Compressor Regulator Valve -N280- -B- lightly with refrigerant oil and check for proper seating (Figure 16).

Figure 16. Check and prepare N280 o-rings

3. Insert the A/C Compressor Regulator Valve -N280- -B- until the stop in the A/C compressor mount -C-.





# Technical Bulletin

---

4. Re install circlip -A-.
5. Install the removed parts in the opposite order.
6. Evacuate and refill the refrigerant circuit.

## Repair Procedure B: Air conditioning compressor replacement.

### Note:

The refrigerant circuit must be flushed every time the A/C compressor is replaced. The replacement A/C compressor comes with a full charge of oil for the entire refrigerant system. Therefore the A/C circuit must be flushed of all original oil form the entire refrigerant circuit.

For this procedure always replace the receiver drier and expansion valve after flushing the refrigerant circuit.

The flushing procedure can be found in Elsa at: Heating, Ventilation & Air Conditioning>>Refrigerant R134a Servicing >>00 General Technical Data>> Refrigerant circuit removing contaminates>>Refrigerant Circuit, Cleaning (Flushing), with Refrigerant R134a. The procedure is also described in Technical Service Bulletin 2019947.

The correct adapters for the 2015 Golf/GTI can be found in Elsa at: Ventilation & Air Conditioning>>Refrigerant R134a Servicing >>00 General Technical Data>> Refrigerant circuit removing contaminates>>Refrigerant Circuit, Cleaning (Flushing), with Refrigerant R134a >>Adapter for Assembling Flushing Circuit.



MY2015 GTI/Golf, SportWagen production have Sanden compressors 5Q0820803C, 5Q0820803E and 5Q0820803G.

The replacement compressor is Denso 5Q0820803F

**Figure 14:** Denso compressor 5Q0820803F



# Technical Bulletin

---



When installing a new compressor transfer the compressor shipping caps to the original compressor as shown in Fig 15.

Figure 15



The replacement Denso compressor will come with the specified type of PAG oil G 052 300 A2 (Figure 16).

**! Note:**

**The compressor comes with a full charge of oil for the entire refrigerant circuit. However the amount of PAG oil supplied with the replacement compressor may not be the exact amount to replenish the refrigerant circuit. Drain and measure the PAG oil in the replacement compressor to determine the required amount. If the amount needs to be adjusted, do so using the correct type of PAG oil specified in ETKA. Refer to Elsa for the correct oil capacity for the compressor being installed.**

Figure 16: Denso compressor manufacturer PAG oil G 052 300 A2.



# Technical Bulletin

## Warranty

**Note:**

Document and attach all workshop findings of this procedure on the repair order.

All replaced compressors must have the shipping caps re-installed before being returned to the WPRC.

| To determine if this procedure is covered under Warranty, always refer to the Warranty Policies and Procedures Manual <sup>1)</sup> |                    |                                         |                         |                                                 |              |
|-------------------------------------------------------------------------------------------------------------------------------------|--------------------|-----------------------------------------|-------------------------|-------------------------------------------------|--------------|
| Model(s)                                                                                                                            | Year(s)            | Eng. Code(s)                            | Trans. Code(s)          | VIN Range From                                  | VIN Range To |
| Golf/GTI,Golf SportWagen                                                                                                            | 2015-2016          | All                                     | All                     | All                                             | All          |
| <b>SAGA Coding</b>                                                                                                                  |                    |                                         |                         |                                                 |              |
| <b>Claim Type:</b>                                                                                                                  |                    | Use applicable Claim Type <sup>1)</sup> |                         |                                                 |              |
| <b>Service Number:</b>                                                                                                              | <b>Damage Code</b> | <b>HST</b>                              |                         | <b>Damage Location (Depends on Service No.)</b> |              |
| 8734                                                                                                                                | 0010               | --                                      |                         | Use applicable when indicated in Elsa (L/R)     |              |
| <b>Parts Manufacturer</b>                                                                                                           |                    | <b>Golf/GTI, Golf SportWagen</b>        |                         | <b>SYP</b>                                      |              |
| <b>Repair Procedure A:</b>                                                                                                          |                    |                                         |                         |                                                 |              |
| <b>Labor Operation <sup>3)</sup>: Refrigerant drain and fill</b>                                                                    |                    |                                         | <b>87031700 = 60 TU</b> |                                                 |              |
| <b>Labor Operation <sup>3)</sup>: N280 valve remove and install</b>                                                                 |                    |                                         | <b>87371950 = 20 TU</b> |                                                 |              |
| <b>Labor Operation <sup>3)</sup>: Noise dampening pan remove and reinstall</b>                                                      |                    |                                         | <b>10821900 = 40 TU</b> |                                                 |              |
| <b>-OR-</b>                                                                                                                         |                    |                                         |                         |                                                 |              |
| <b>Repair Procedure B: (if A/C compressor is necessary)</b>                                                                         |                    |                                         |                         |                                                 |              |
| <b>Labor Operation <sup>3)</sup>: Refrigerant drain and fill</b>                                                                    |                    |                                         | <b>87031700 = 60 TU</b> |                                                 |              |
| <b>Labor Operation <sup>3)</sup>: Noise dampening pan remove and reinstall</b>                                                      |                    |                                         | <b>10821900 = 40 TU</b> |                                                 |              |



# Technical Bulletin

|                                                                                                                                                                      |                                                                                                                                  |
|----------------------------------------------------------------------------------------------------------------------------------------------------------------------|----------------------------------------------------------------------------------------------------------------------------------|
| Labor Operation <sup>3)</sup> : N280 valve remove and install (with debris on filter screen found)                                                                   | 87371950 = 20 TU                                                                                                                 |
| Labor Operation <sup>3)</sup> : A/C compressor remove and reinstall                                                                                                  | 87341970 = 50 TU (1.8/2.0 TFSI)<br>87341955 = 40 TU (2.0 TDI)                                                                    |
| Labor Operation <sup>3)</sup> : Expansion valve remove and reinstall                                                                                                 | 87701970 = 50 TU (1.8/2.0 TFSI)<br>87701955 = 60 TU (2.0 TDI)                                                                    |
| Labor Operation <sup>3)</sup> : Radiator grill remove and reinstall                                                                                                  | 66051900 = 20 TU                                                                                                                 |
| Labor Operation <sup>3)</sup> : Receiver drier replace (non-Modine)                                                                                                  | 87555550 = 30 TU                                                                                                                 |
| Labor Operation <sup>3)</sup> : Receiver drier replace (Modine)                                                                                                      | 87555552 = 40 TU                                                                                                                 |
| Labor Operation <sup>3)</sup> : Air conditioner clean                                                                                                                | 87012999 = 140 TU                                                                                                                |
| Outside Material: A/C Flush Machine Behr filter, Part No. BA1783400103                                                                                               | \$4.25 total per A/C System Flush which accompanies a repair (this amount equals ¼ of the cost of the A/C flush machine filter)  |
| OR                                                                                                                                                                   |                                                                                                                                  |
| Outside Material: A/C Flush Machine Bosch filter, Part No. 17707-6                                                                                                   | \$17.88 total per A/C System Flush which accompanies a repair (this amount equals ¼ of the cost of the A/C flush machine filter) |
| Causal Part:                                                                                                                                                         | 5Q0260839A                                                                                                                       |
| Diagnostic Time <sup>4)</sup>                                                                                                                                        |                                                                                                                                  |
| GFF Time expenditure                                                                                                                                                 | 01500000 = 55 TU max. YES                                                                                                        |
| Road Test                                                                                                                                                            | 01210002 = 10 TU<br>01210004 = 10 TU YES                                                                                         |
| Technical Diagnosis                                                                                                                                                  | 01320000 = 20 TU max. YES                                                                                                        |
| Claim Comment: Input "As per Technical Bulletin 2038368" in comment section of Warranty Claim.                                                                       |                                                                                                                                  |
| <sup>1)</sup> Vehicle may be outside any Warranty in which case this Technical Bulletin is informational only<br><sup>2)</sup> Code per warranty vendor code policy. |                                                                                                                                  |



# Technical Bulletin

---

- 3) Labor Time Units (TUs) are subject to change with ELSA updates.**
- 4) Documentation required per Warranty Policy Procedures Manual.**



# Technical Bulletin



---

## Required Parts and Tools

| Part Description                                      | Part No:   | Quantity              |
|-------------------------------------------------------|------------|-----------------------|
| N280 Regulating Valve (Sandán)                        | 5Q0260839A | 1                     |
| -OR—<br>(if A/C compressor is necessary)              |            |                       |
| Oil for refrigerant compressor (Denso)                | G 052300A2 | 0.2 (Max if required) |
| Air conditioner compressor (Denso)                    | 5Q0820803F | 1                     |
| Seal ring                                             | 4D0260749B | 1                     |
| Seal ring                                             | 4E0260749B | 1                     |
| Seal ring                                             | 4E0260749A | 1                     |
| Seal ring                                             | 8E0260749C | 1                     |
| Drier insert with mounting parts                      | 5Q0298403A | 1                     |
| Expansion Valve<br>(With Compressor replacement only) | 5Q0820679C | 1                     |
| Set of round seals                                    | 5Q0898850A | 1                     |





# Technical Bulletin

| Tool Description                                                                                                                                                                                    | Tool No:                                                                                                   |
|-----------------------------------------------------------------------------------------------------------------------------------------------------------------------------------------------------|------------------------------------------------------------------------------------------------------------|
|  <p data-bbox="389 619 503 651">VAS6337/1A</p> <p data-bbox="138 829 462 861"><b>Robinair A/C Service Unit</b></p> | <p data-bbox="1063 493 1226 525"><b>TOOL NO:</b></p> <p data-bbox="1063 493 1226 525"><b>ROB134APF</b></p> |
|  <p data-bbox="138 1228 495 1260"><b>Air Conditioning Flush Tool</b></p>                                          | <p data-bbox="1063 892 1226 924"><b>VAS 6337/1A</b></p>                                                    |
| <p data-bbox="138 1291 738 1323"><b>Air Conditioning System Flushing Device Filter</b></p>                       | <p data-bbox="1015 1291 1274 1323"><b>Behr - BAI783400103</b></p>                                          |
| <p data-bbox="787 1690 836 1722"><b>OR</b></p>                                                                                                                                                      |                                                                                                            |



# Technical Bulletin

|                                                                                                                                                |                               |
|------------------------------------------------------------------------------------------------------------------------------------------------|-------------------------------|
| <p><b>Air Conditioning System Flushing Device Filter</b></p>  | <p><b>Bosch – 17707-6</b></p> |
|  <p><b>Refrigerant Circuit Adapter 3</b></p>                 | <p><b>VAS 6338/3</b></p>      |
|  <p><b>Refrigerant Circuit Adapter 12</b></p>               | <p><b>VAS 6338/12</b></p>     |
|  <p><b>Refrigerant Circuit Adapter 38</b></p>               | <p><b>VAS 6338/38</b></p>     |





# Technical Bulletin

---

## Additional Information

All part and service references provided in this Technical Bulletin are subject to change and/or removal. Always check with your Parts Dept. and Repair Manuals for the latest information.