

# Technical Service Bulletin



## 01 MIL on (DTC P2006(00) or P2007(00))

01 14 60 2033919/12 January 21, 2014. Supersedes Technical Service Bulletin Group 01 number 13-34 dated October 8, 2013 for reasons listed below.

Model(s)	Year	VIN Range	Vehicle-Specific Equipment
S4, S5, S5 Cabriolet, A6, A7, Q5, Q7	2013	All	3.0 FSI Engine

## Condition

REVISION HISTORY		
Revision	Date	Purpose
12	-	Revised header data (Updated engine codes) Revised <i>Service</i> (Modified step 2 under <i>Service</i> heading)
11	10/8/2013	Revised <i>Service</i> (Added Tip)
10	8/29/2013	Revised <i>Service</i> (Added Tips)
9	8/2/2013	Revised <i>Service</i> (Added steps) Revised <i>Warranty</i> (Updated labor operations)
8	7/19/2013	Revised <i>Required Parts and Tools</i> (Updated part numbers)
7	7/9/2013	Revised header data (Added model year)
6	6/26/2013	Revised <i>Service</i> (Replace both actuators)
5	6/18/2013	Revised <i>Required Parts and Tools</i> (Updated quantity)
4	6/7/2013	Revised <i>Service</i> (Removed step regarding calling TAC)
3	5/29/2013	Revised header data (updated engine codes)
2	5/28/2013	Revised <i>Service</i> (Added steps and image)
1	5/16/2013	Initial publication

- MIL on.
- One or both of the following DTCs is stored in the engine control module, J623 (address word 01):
  - **DTC P2006(00)** (Intake Manifold Runner Control Stuck Closed, Bank 1).
  - **DTC P2007(00)** (Intake Manifold Runner Control Stuck Closed, Bank 2).
- There may be slight power reduction at high RPMs.

## Technical Background

One of the vacuum actuators on intake runner bank 1 or bank 2 is defective. It is possible that the membrane on the vacuum actuator may tear. As a result, the intake manifold flaps do not function.

## Production Solution

Updated vacuum actuator.

## Service

1. Ensure that the fault is not caused by a defective vacuum line by using the vacuum pump (Figure 1) to confirm there is no leak in the vacuum supply to the actuators.

The vacuum lines are working correctly if they are able to maintain vacuum while the actuators are disconnected and the lines are plugged up.

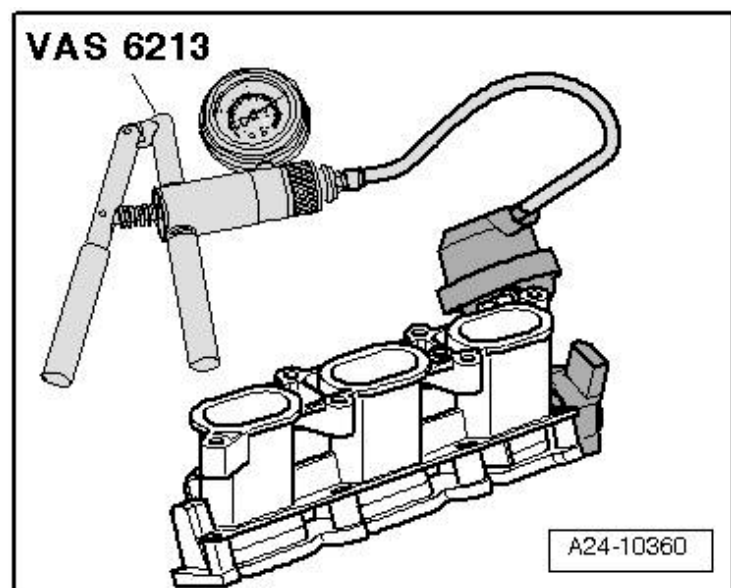
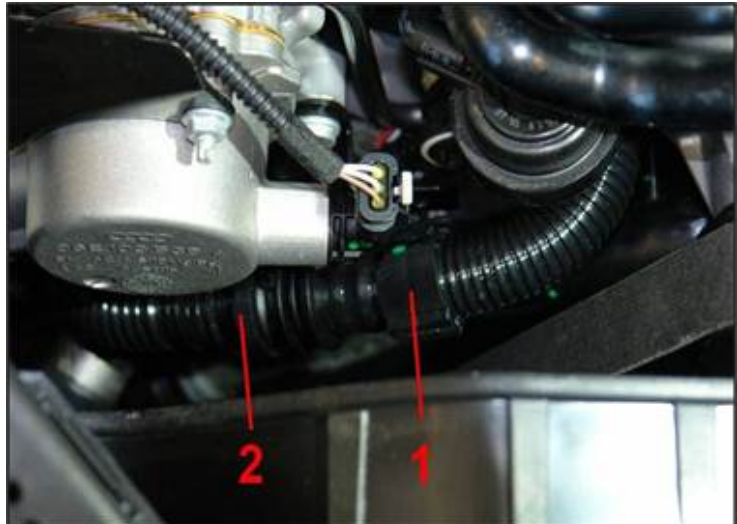

**Figure 1.** Vacuum pump VAS 6213

2. After confirming that the fault is not due to defective vacuum lines, test the vacuum actuator. Apply vacuum to at least 15" of water. If the vacuum does not hold (goes all the way to zero), replace **both** vacuum actuators (bank 1 and bank 2 actuator) by following the instructions below. Both actuators must be replaced in order to prevent any repeat repairs.

## Replacing the passenger side vacuum actuator

1. Unclip the secondary air injection line from the bracket (Figure 2, 1) and disconnect the coupling (Figure 2, 2) by pushing both release tabs at the same time (one in the front one in the back).



**Figure 2.** Bracket (1) and coupling (2) to disconnect from the secondary air injection line

2. Remove the intake manifold runner position sensor by using a ball head torx bit to remove the screws (Figure 3, arrows).

**Note:**

To prevent the sensor from falling, do not disconnect the connector.



**Tip:** Place a shop rag under the screws to catch any screws that drop.



**Tip:** To prevent losing the screws, use a non-bonding adhesive on the tip of the ball torx bit and use a magnet to hold them during removal.

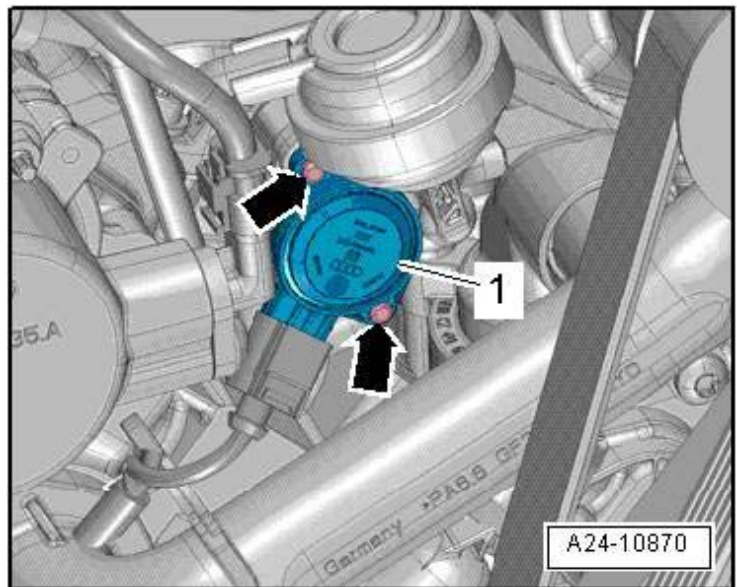

**Figure 3.** Intake manifold sensor (1) and bolts (arrows)



**Tip:** The T10 ball head torx bit is sourced locally (Figure 4). Examples include: Snap-on Tools SDM32KT or SDMBT10, or VIM Tools VIS108 or VIS112.



**Figure 4.** T10 ball head torx bit.

3. Disconnect the vacuum hose (Figure 5, 1), then pry the vacuum actuator (Figure 5, 2) off of the ball head (Figure 5, 3).

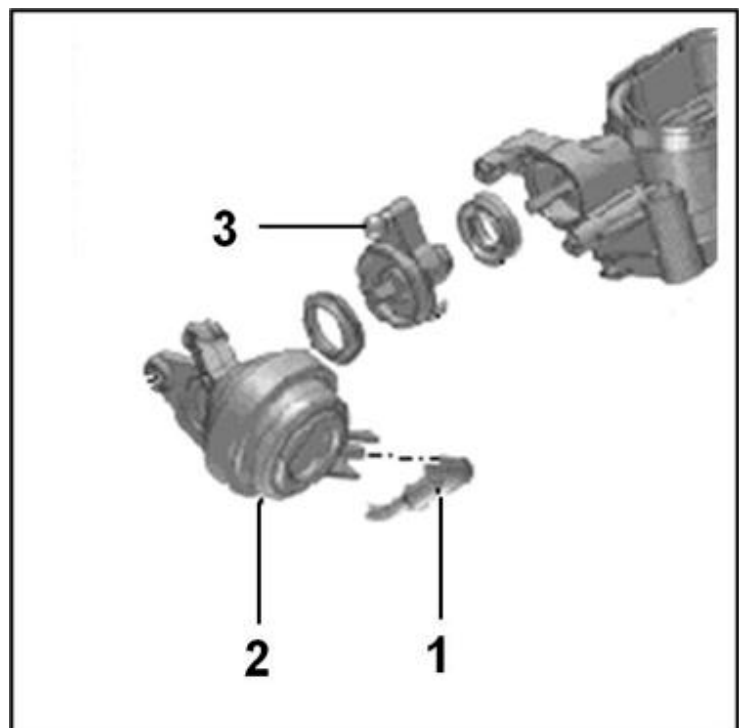

**Figure 5.** Vacuum hose (1), vacuum actuator (2), and ball head (3)

4. Reinstall the new actuator by following the above steps in reverse order.



**Tip:** If the intake runner position sensor has lost its zero position, ensure that the rectangular hole of the sensor lines up with the rectangular shaft. The zero position of the bank 1 sensor is ~15° off the clockwise end stop and the bank 2 sensor is ~15° off the counterclockwise end stop. Do not use any force to install the sensor.

## Replacing the driver side vacuum actuator

1. Raise the vehicle and remove the front noise insulation panel.
2. Remove the screw (Figure 6, arrow) from the coolant line and upper section of oil pan. This will allow the coolant lines to be moved out of the way when removing the sensor.

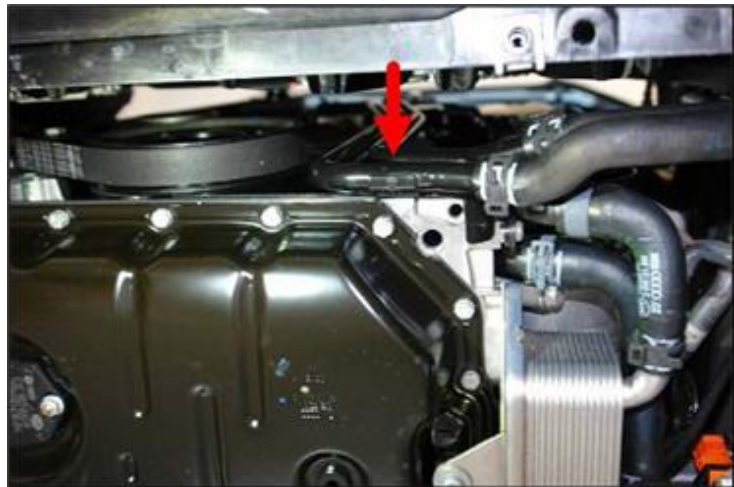

**Figure 6.** Screw to be removed from coolant line and upper section of oil pan (arrow)

3. Place the drip tray for workshop crane VAS 6208 under the engine.
4. Disconnect the following (Figure 7):
  - Charge air pressure sensor
  - Engine coolant temperature sensor
  - Camshaft position sensor
  - Solenoid valve

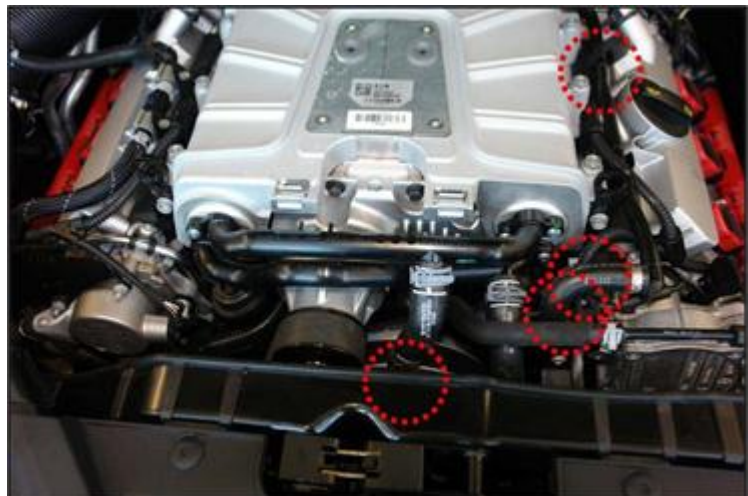
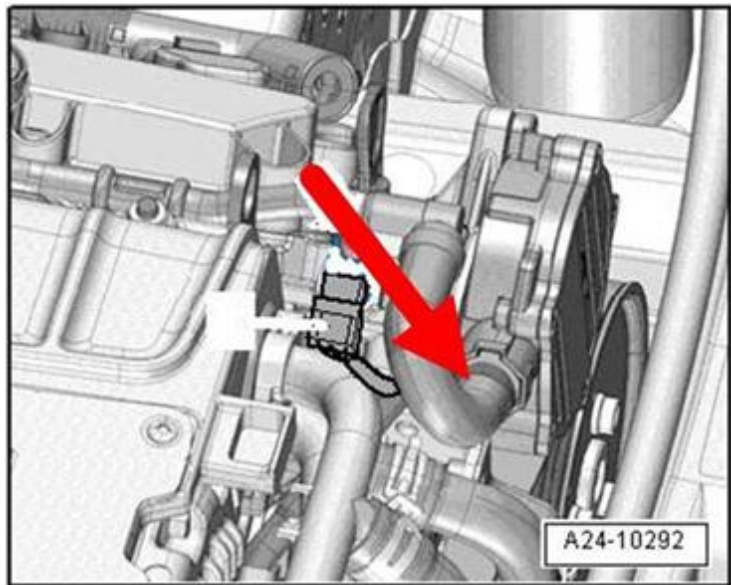

**Figure 7.** Sensors and valve that need to be disconnected are circled in red.

5. Lay the wiring harness aside.



6. Disconnect the vacuum hose (Figure 8, arrow) from the vacuum pump and lay it aside.



**Figure 8.** Vacuum hose (arrow)

7. Remove the bolt as shown in the image at right (Figure 9, 2)

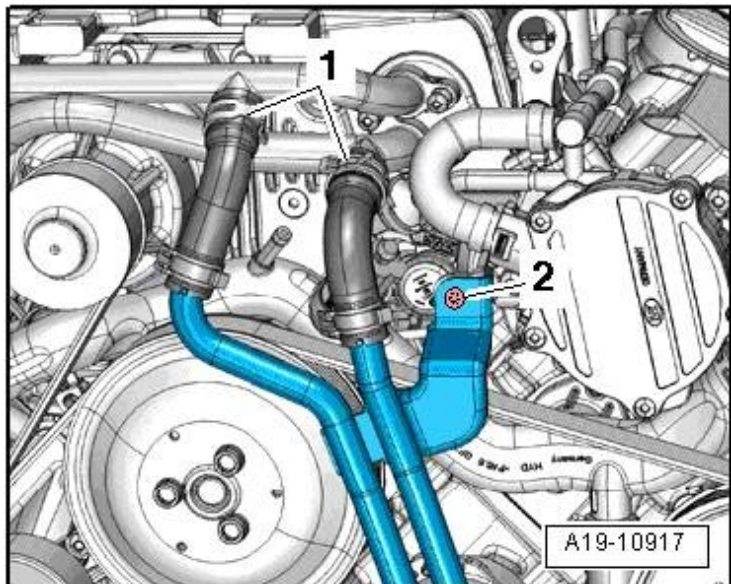

**Figure 9.** Bolt to be removed (2)

8. Remove coolant hoses (Figure 10, arrows) and close them off with fitting caps (yellow caps from VAS 6122). Move the coolant hoses to the side for access to the intake runner position sensor.



Figure 10. Coolant hoses (arrows)

9. Collect any coolant that is draining.
10. Remove the intake manifold runner position sensor by using a ball head torx bit to remove the bolts. To ensure good torx bit to bolt head contact, apply force in the direction of the arrow (Figure 11, arrow).

 **Note:**

To prevent the sensor from falling, do not disconnect the connector.

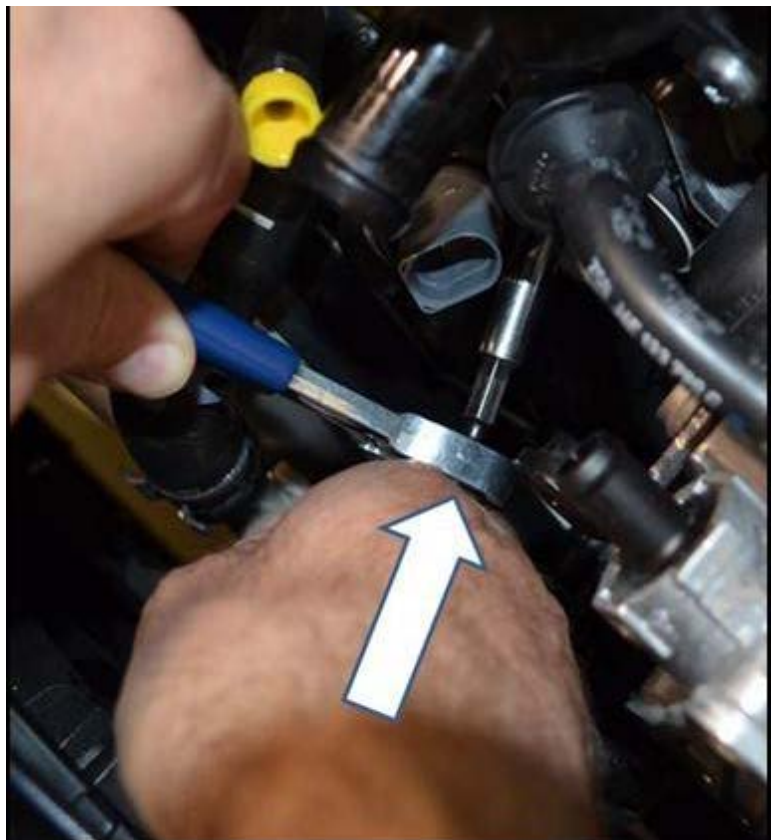

Figure 11. Apply force in the direction of the arrow.



**Tip:** Place a shop rag under the screws to catch any screws that drop (Figure 12).



**Figure 12.** Place a shop rag under the screws.



**Tip:** To prevent losing the screws, use a non-bonding adhesive on the tip of the ball torx bit and use a magnet to hold them during removal (Figure 13).



**Figure 13.** Use a magnet (arrow) to hold the screws during removal.



11. Pry the vacuum actuator (Figure 14, 2) off of the ball head (Figure 14, 3), then disconnect the vacuum hose (Figure 14, 1).

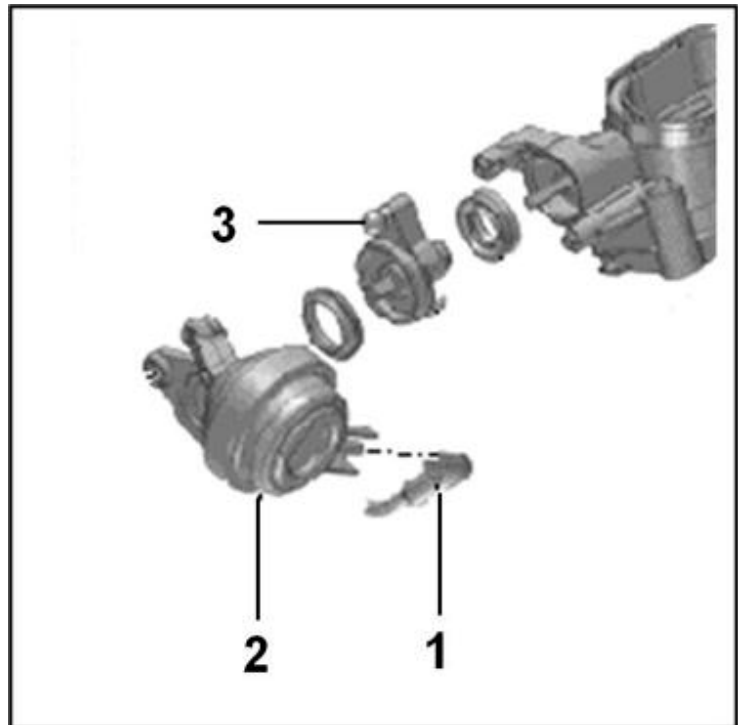

**Figure 14.** Vacuum hose (1), vacuum actuator (2), and ball head (3)

12. Reinstall the new actuator by following the above steps in reverse order.



**Tip:** If the intake runner position sensor has lost its zero position, ensure that the rectangular hole of the sensor lines up with the rectangular shaft. The zero position of the bank 1 sensor is ~15° off the clockwise end stop and the bank 2 sensor is ~15° off the counterclockwise end stop. Do not use any force to install the sensor.

13. Top off coolant, if necessary.

# Technical Service Bulletin



## Warranty

<b>Claim Type:</b>	Use applicable claim type. If vehicle is outside any warranty, this Technical Service Bulletin is informational only.		
<b>Service Number:</b>	2464		
<b>Damage Code:</b>	0010		
<b>Labor Operations:</b>	Both vacuum actuators remove+reinstall	2464 2099	90 TU
<b>Diagnostic Time:</b>	GFF	0150 0000	Time stated on diagnostic protocol (Max 20 TU)
	Road test prior to service procedure	No allowance	0 TU
	Road test after service procedure	0121 0004	10 TU
	Technical diagnosis at dealer's discretion (Refer to Section 2.2.1.2 and Audi Warranty Online for DADP allowance details)		
<b>Claim Comment:</b>	As per TSB # 2033919/12		

All warranty claims submitted for payment must be in accordance with the *Audi Warranty Policies and Procedures Manual*. Claims are subject to review or audit by Audi Warranty.

## Required Parts and Tools

Part number	Part Description	Quantity
06E133159M	Actuator left	1
06E133159N	Actuator right	1
G 012A8G1G	Coolant top-off	0.3
N 10201801	Clamp	1

Tool Number	Tool Description
VAS 6213	Vacuum pump
VAS 6122	Coolant hose cap-off set

# Technical Service Bulletin

---



## Additional Information

All parts and service references provided in this TSB (2033919) are subject to change and/or removal. Always check with your Parts Department and service manuals for the latest information.