

	Date	Group	No.	Release	Page
This Field Service Bulletin replaces bulletin "Range Synchronizer, Repair", (USA70647) PV729-FSB431-010_M, dated 04/2015.	10.2017	431	010	03	1(36)

Range Synchronizer, Repair
CHU, CXU

FSB 431-010, Range Synchronizer, Repair

(October 2017)

This procedure is to repair mDrive transmissions in the field that exhibit a grinding noise when the transmission range shifts (for example: between 6th and 7th gear) built between 01/01/2013 and 08/18/2014.

Required Parts

I-Shift Range Synchronizer Repair Kit, Part Number 85020354
TECU main software equal to or greater than 23084204

Optional Parts

Note: The assembly should be disassembled and inspected before ordering optional parts.

Range Shift Fork, Part Number 21510395
Set Screws, Part Number 1652847

Required Tools

Special tools: 9809726, 9990027, 9992619, 9992671, 9992884, 9996315, 9996876, 9996889, 9996917, 9998051, 9998542, 85108826, 88800015

Premium Tech Tool version 2.06.20 or higher
Vocom Diagnostic Connector 88890304 or 88890253
Communication Interface 88890300

Note: Using other interfaces may affect programming speed.

Note: Check Premium Tech Tool version by clicking on Help tab and then click on "About Tech Tool".

Failed Parts



W4096430

The synchronizer ring is missing the high range friction material and the low range side is wearing away.

Procedure

You must read and understand the precautions and guidelines in Service Information, Function Group 40, "General Safety Practices, Transmission" before performing this procedure. If you are not properly trained and certified in this procedure, ask your supervisor for training before you perform it.

DANGER

Do not attempt to repair or service this vehicle without having sufficient training, the correct service literature and the proper tools. Failure to follow this could make the vehicle unsafe and lead to serious personal injury or death.

DANGER

Before beginning any work on any part of the air system, be certain that the air pressure has been released. Failure to do so may cause a component to violently separate, which can result in serious personal injury.

Note: Special tools: 9809726, 9990027, 9992619, 9992671, 9992884, 9996315, 9996876, 9996889, 9996917, 9998051, 9998542, 85108826, 88800015

- 1 Use Premium Tech Tool (PTT) to perform operation 4000-08-03-11 "Gear activation, control housing (for removal/replacement)". Follow the instructions in PTT.

Note: If Tech Tool is unable to activate the necessary gears for control housing removal, follow the manual activation steps outlined in this procedure after transmission removal.

- 2 Secure the vehicle for service by parking it on a flat level surface, applying the parking brake, chocking the rear wheel, and placing the transmission in neutral.
- 3 Disconnect all cables from the negative (ground) battery terminals to prevent personal injury from electrical shock and prevent damage to electrical components.
- 4 Drain the air system.
- 5 Raise the vehicle and support with jack stands.

6 Drain the transmission oil into a suitable container.



WARNING

Hot transmission oil can cause burns. DO NOT allow hot transmission oil to contact the skin. When changing transmission oil, wear protective gloves.



CAUTION

Always dispose of lubricants (engine oil, coolant, transmission oil, etc.) and filters according to Federal or local regulations. Dumping used oil or coolant on the ground or in waterways can contaminate our drinking water and kill wildlife.

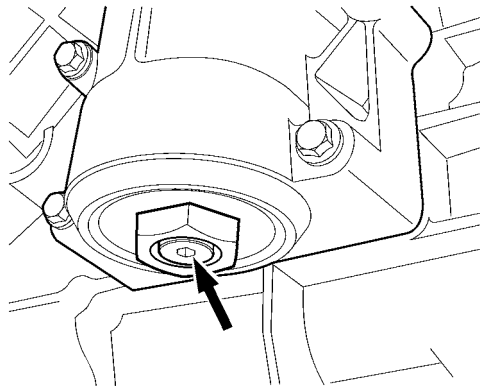

W4002889

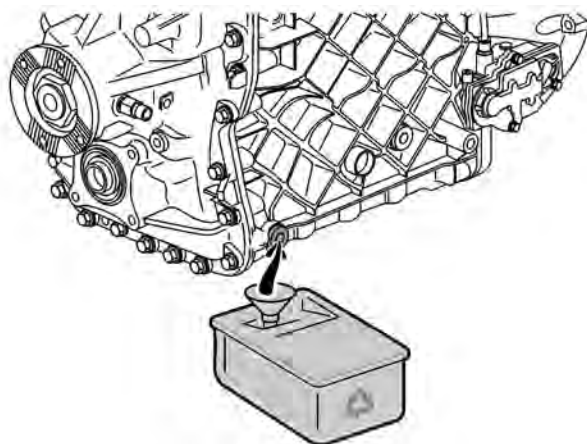

T4022639

- 7 Remove the transmission. Refer to Function Group 431.
- 8 Remove the control housing mounting bolts.

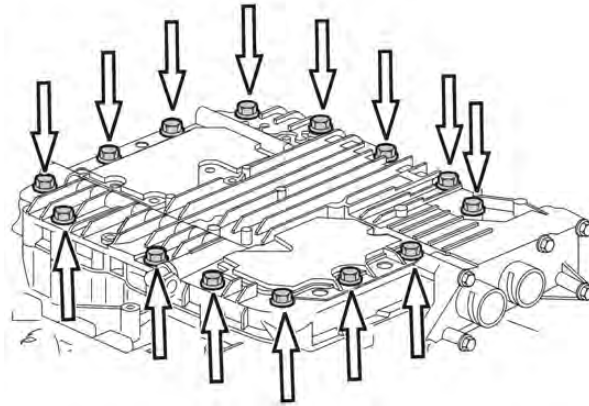

W4002951

- 9 Remove the six TECU mounting bolts.

Note: It is **only** necessary to perform this step if manually performing the “Gear activation, control housing (for removal/replacement)”. If PTT activated the necessary gears, proceed to step 13.

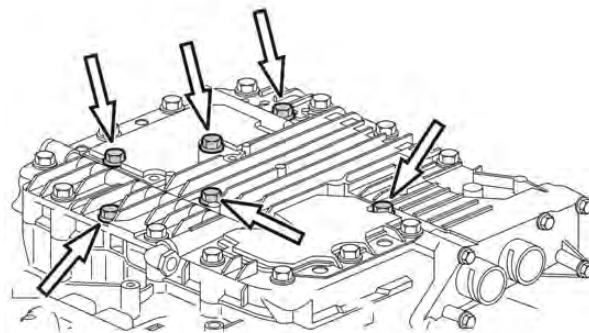

W4002952

10 Manually perform the “Gear activation, control housing (for removal/replacement)” as outlined in the next three steps.

Note: The next three steps are performed **only** if Tech Tool could not activate the necessary gears for control housing removal.

11



CAUTION

Electrical components, including the wiring harness inside the transmission control housing, are delicate. Handle with extreme care. Failure to do so may result in damage to components.

Gently lift the top edge of the upper cover and angle it down carefully against the clutch housing. Carefully disconnect the electrical connection and remove the top cover.

Note: Do not apply tension or weight to the wiring harness or connector.

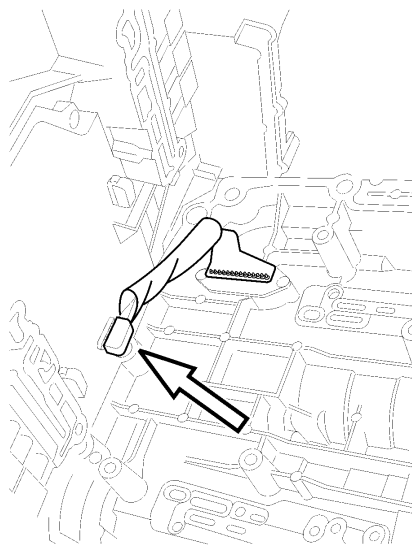

W4002953

12 Using compressed air, apply air pressure to the appropriate bore holes to place the transmission gears in the proper position for control housing removal.

Note: It is necessary to rotate the input shaft while engaging the splitter section to mesh the gears.

Note: It is necessary to rotate the output shaft while engaging the range section to mesh the gears.

Note: It is necessary to rotate the output or input shaft while engaging reverse to mesh the gears.

Note: For over drive transmissions, the transmission must be positioned as follows:

- * Low Split
- * High Range
- * 2nd/3rd — Neutral Position
- * 1st/Reverse — Reverse Position

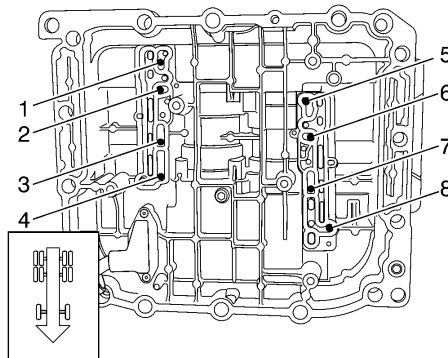

W4002895

Over Drive Transmission

- 1 – High Range
- 2 – 3rd Gear
- 3 – Low Range
- 4 – 2nd Gear
- 5 – 1st Gear
- 6 – High Split
- 7 – Reverse Gear
- 8 – Low Split

Note: For direct drive transmissions, the transmission must be positioned as follows:

- * High Split
- * High Range
- * 2nd/3rd — Neutral Position
- * 1st/Reverse — Reverse Position

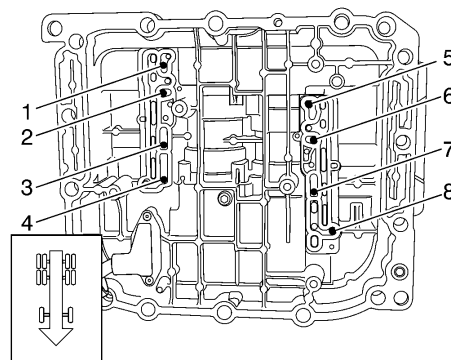

W4002895

Direct Drive Transmission

- 1 – High Range
- 2 – 3rd Gear
- 3 – Low Range
- 4 – 2nd Gear
- 5 – 1st Gear
- 6 – Low Split
- 7 – Reverse Gear
- 8 – High Split

Note: If 2nd or 3rd gear is engaged, it will be necessary to position that gear set to neutral before attempting to engage reverse.

Note: To engage neutral for the 2nd/3rd gear set, it will be necessary to gently apply air to the bore holes. If too much air is applied, it will engage one of the two gears. To aid positioning, **do not** rotate the shaft when attempting to position this gear set.

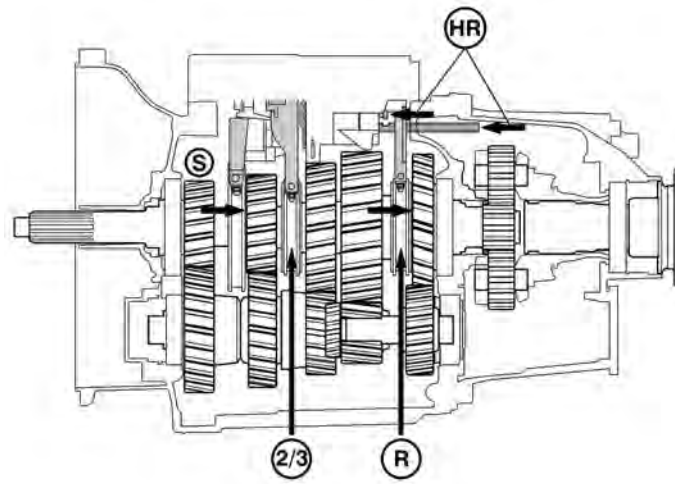

T4021451

13



CAUTION

Gentle consistent pressure should be used to lift the control housing from the transmission. Applying excessive force is not necessary or needed, and may result in damage to components.



CAUTION

Always install the alignment pins before removing the control housing to prevent damage to the transmission main shaft speed tone ring and the shift control.

Note: Use tool **9996876**.

Install the alignment pins through the control housing into the transmission. Using a pry bar, gently separate the control housing from the locating pins on the transmission, then remove the control housing.

Note: If the control housing does not separate from the transmission while applying gentle pressure upward, it may be necessary to refer back to Step 11 or Step 12 before attempting control housing removal again.

Note: Exercise care during removal to keep from damaging the tooth wheel in the transmission.

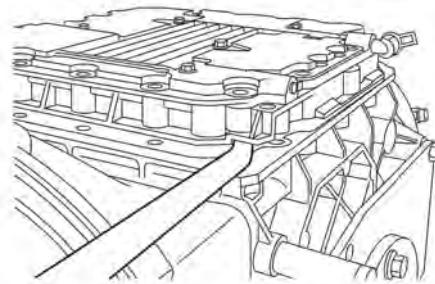

W4002955

14 Remove the plug, spring and plunger for the range function. If necessary use a magnet to pull out the plunger.

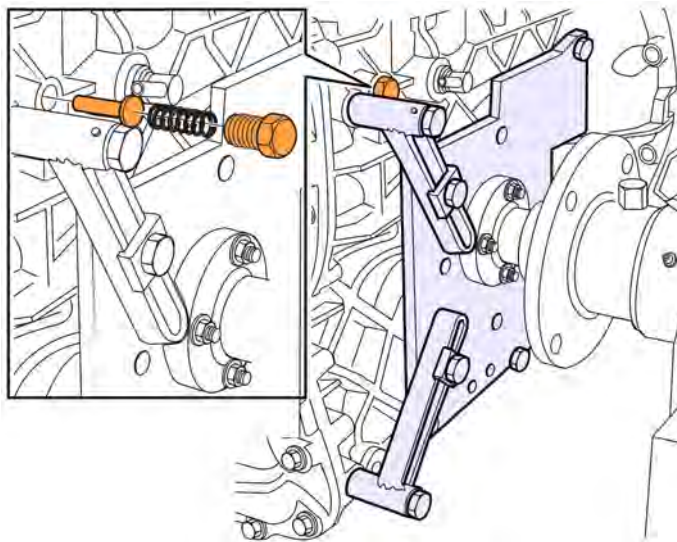

C4052785

15 Remove the range housing mounting fasteners.

16 Use press tool to separate the main housing and range housing.

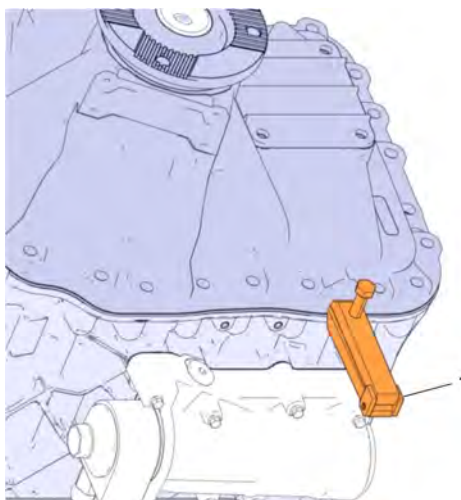

W4088216

1. 9998051

17 Carefully lift the range housing away from the main housing.



CAUTION

Ensure that the range cylinder piston rod does not jam in the main housing. Damage to the shaft may result.

18 Remove the range gear fasteners.

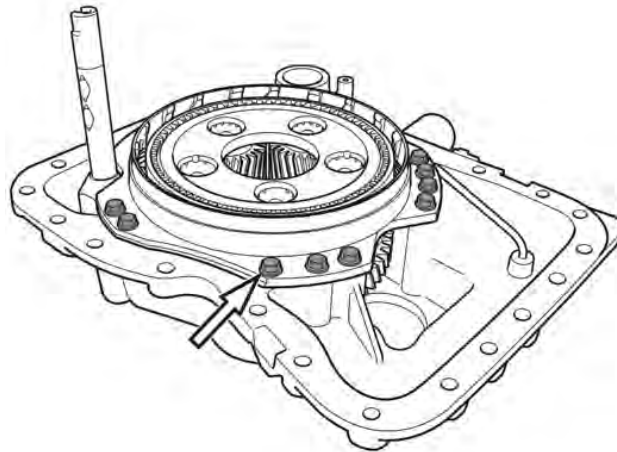

T4021492

19 Mark the orientation of the fork shaft to the synchronizer ring. Remove the range gear.

Note: Gear must be in high range for removal. If difficult to remove, lift on the shaft and tap down on the housing with a dead blow hammer.

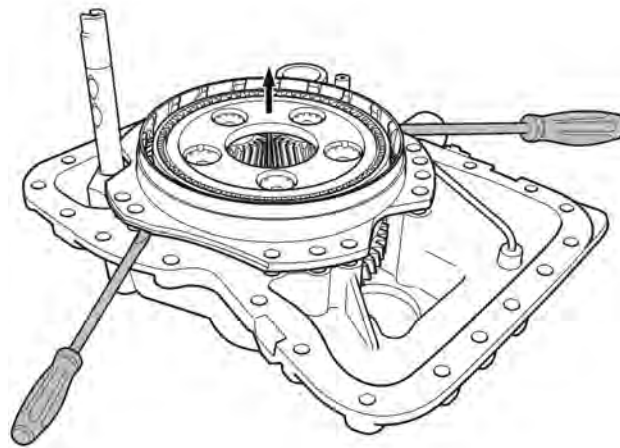

T4021493

20 Remove the selector fork. Check the brass shifter pads. If the brass shifter pads are damaged or worn, replace the fork. Tighten the set screws to 75 ± 7 Nm (55 ± 5 lb-ft) and stake set screws.

Note: After staking, set screws are one time use only.

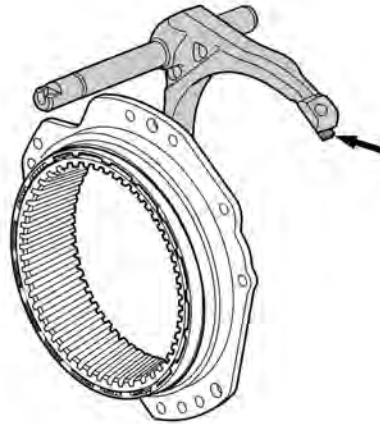

T4023050



W4096194

The fork should be replaced if there is this type of damage.



W4096195

Properly Staked Set Screws

21 Remove the oil return pipe.

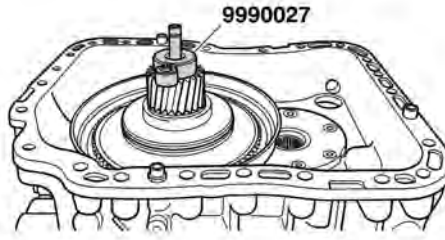

T4021428

22 Remove the retaining ring.

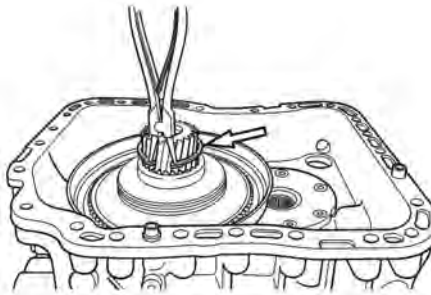

T4021426

23 Remove the washer.

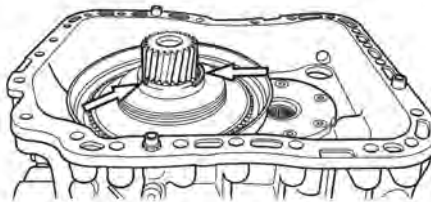

T4021427

24 Install the puller rings.

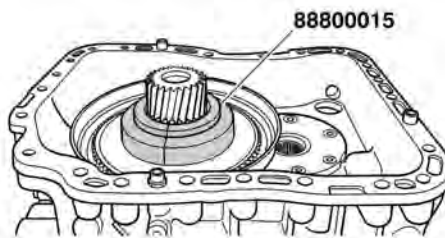

T4021425

25 Install one half of the puller on puller rings together with the hydraulic cylinder, spindle and drift.

Note: Check that the divide in the puller rings is at 90° to the divide in the puller.

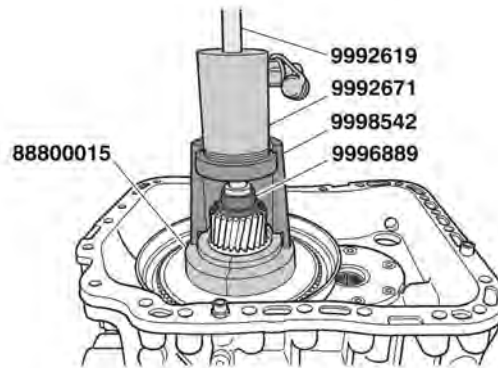

T4021429

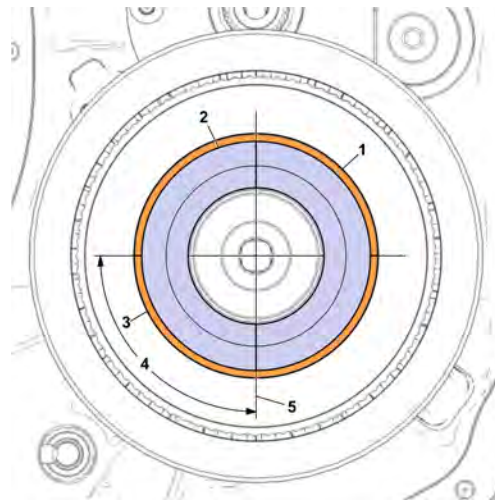

W4089791

1. 88800015
2. Puller Ring
3. 9998542
4. 90° Position for Tool
5. Tool Set on Puller Ring

26 Install the other half of the puller and the hydraulic pump. Remove the high range engaging ring.

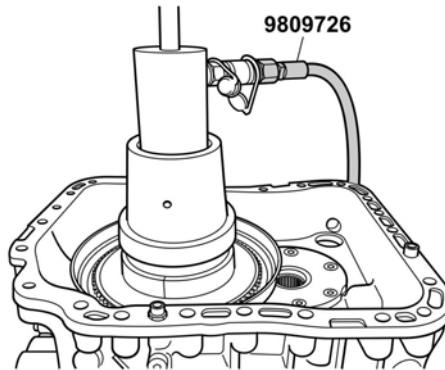

W4097639

27 Clean and inspect all components.

Note: The synchronizing ring (B) must not be washed.

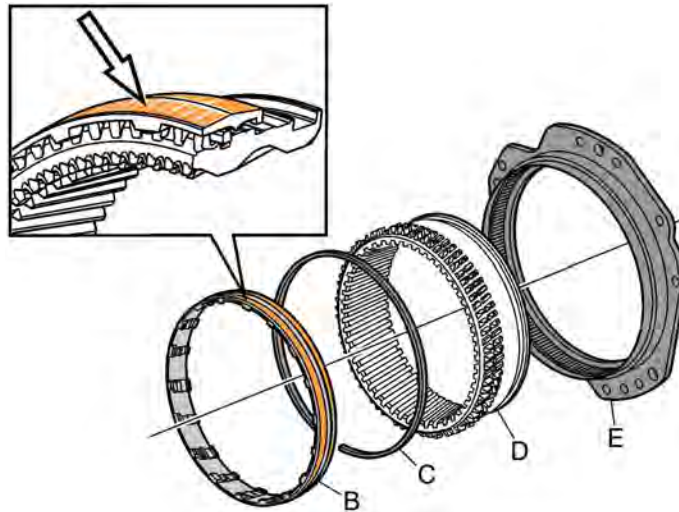

T4028370

28 Check the part number of the spacer. If the part number is 20533124 then replace the spacer with a new spacer included in the kit.

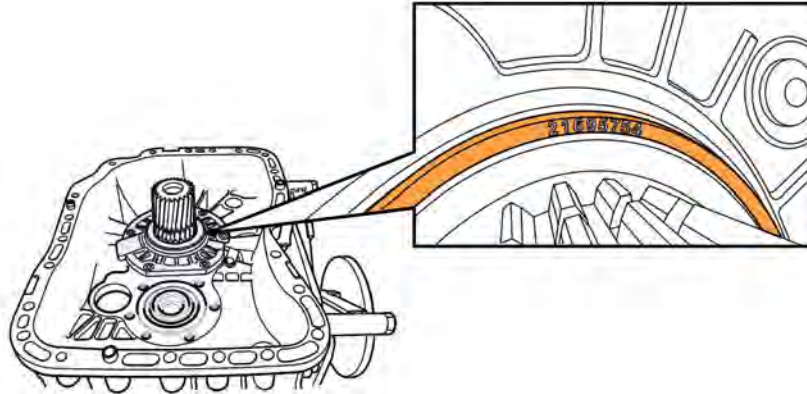

W4089323

Note: The next four steps are required **ONLY** if the spacer is replaced.

29 Remove the rear cover for the main shaft and where applicable oil pipe for overdrive gear.

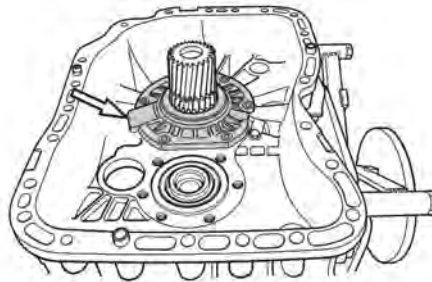

T4021434

30 Remove the adjustment shim for the main shaft.

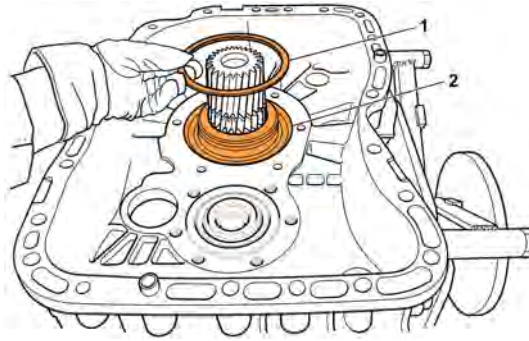

W4088866

1. Shim
2. Spacer

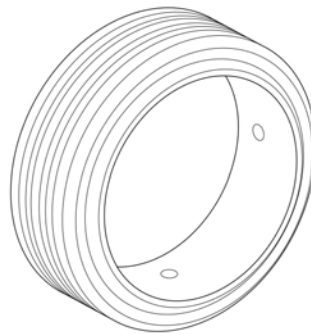

W4089450

Spacer

31 Remove the spacer with a suitable tool and replace with the spacer included in the kit.

32 Reinstall the shim and the rear cover. Tighten fasteners to 48 ± 5 Nm (35 ± 4 ft-lb).

33 Press in a new high range engaging ring.

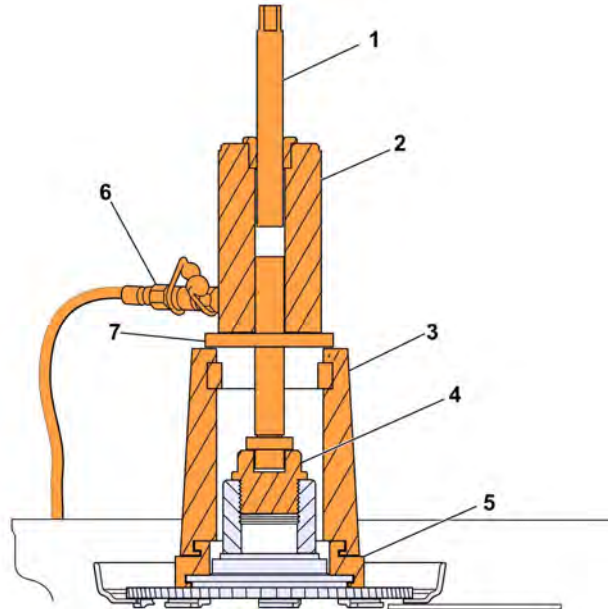

W4101437

1. 9996315
2. 9992671
3. 9998542
4. 9996917
5. 88800015
6. 9809726
7. 9992884

34 Install both washer halves.

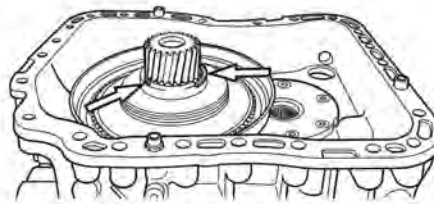

T4021427

35 Install the retaining ring from the kit.

Note: There are several rings in the kit. Install the thickest ring that will seat correctly in the groove.

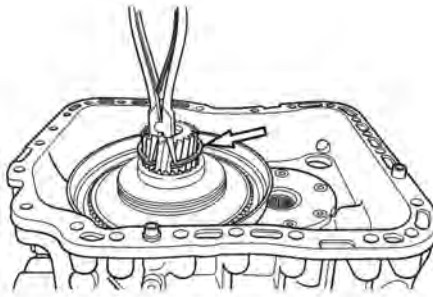

T4021426

36 Oil and install O-rings. Install the oil return pipe. Tighten to 250 ± 50 Nm (184 ± 37 lb-ft).

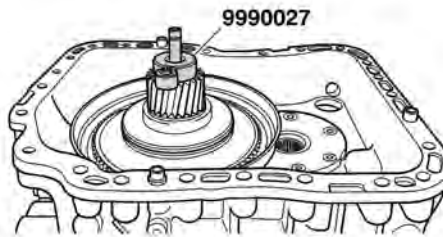

T4021428

37 Clean old sealant off the range housing.

38 Lubricate sliding surfaces and O-rings with transmission fluid during assembly. It is important to lubricate the carbon fiber lining on synchronizing ring (B).

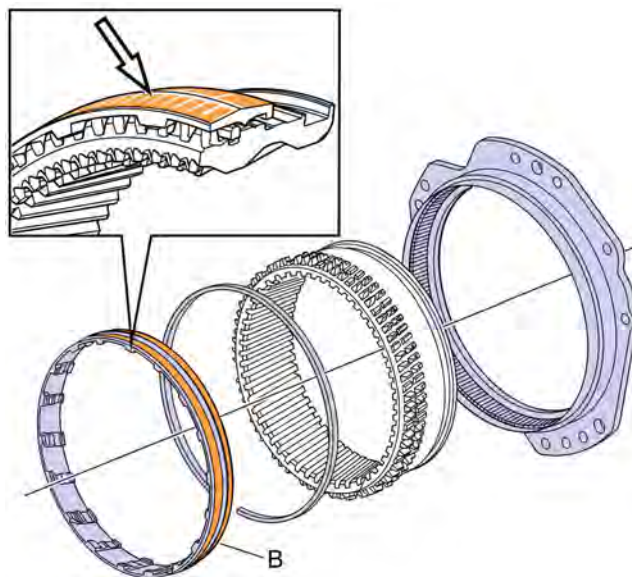

W4128577

39 Lubricate the short end of the shaft before installation. Install the engaging ring and selector fork on the ring gear. Use the orientation mark to properly align new parts.

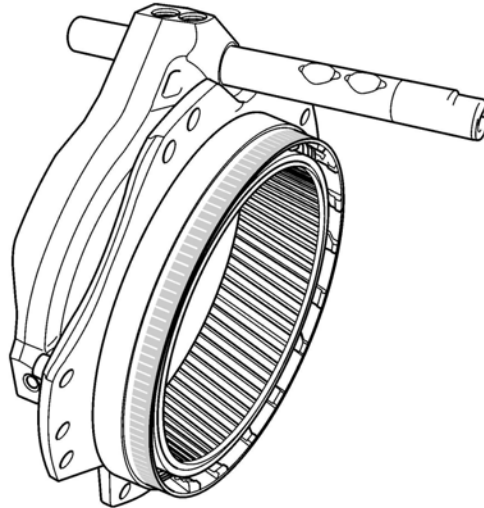

T4028364

40 To ensure correct operation, it is important that wide tooth (D) on the synchronizing ring (C) line up with a chamfered (angled) tooth (A) on the ring gear (B) as illustrated below.

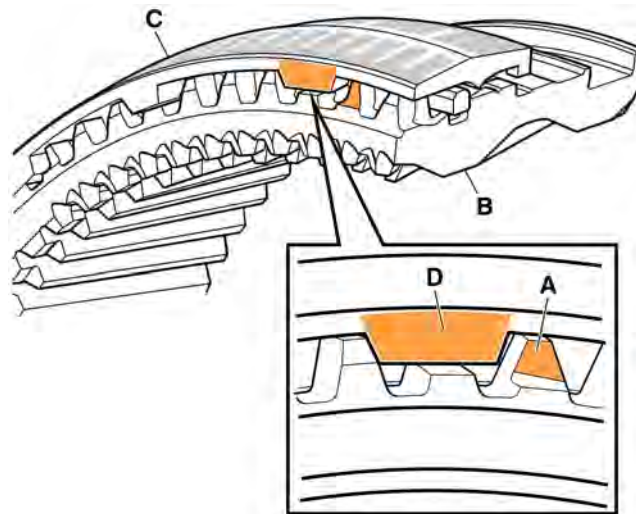

W4128578

41 Use the inspection guide in the figure below to ensure proper assembly before installation of the package into the range housing.

Note: Improper assembly of these components will cause gear clash on range downshifts.

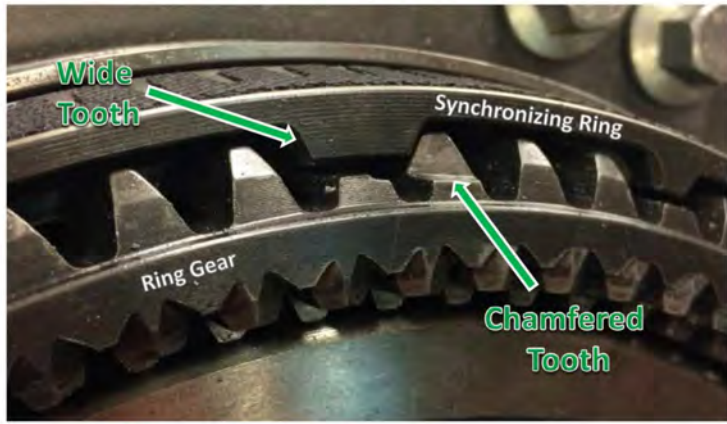
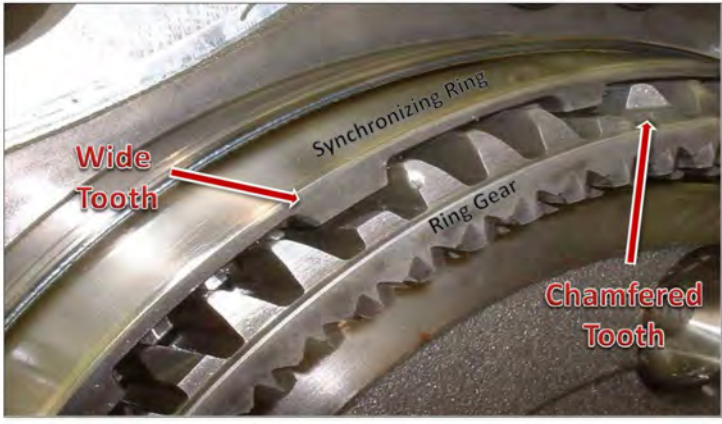
Package Inspection Guide	
<h3 style="text-align: center;">CORRECT ASSEMBLY</h3>  <p style="text-align: right;">W4128579</p>	
<p style="text-align: center;">Notice the wide tooth of the synchronizing ring is next to the chamfered (angled) tooth of the gear ring.</p>	
<h3 style="text-align: center;">INCORRECT ASSEMBLY</h3>  <p style="text-align: right;">W4128580</p>	
<p style="text-align: center;">The wide tooth of the synchronizing ring is not next to the chamfered (angled) tooth of the ring gear.</p>	

- 42 Install the package in the range housing. Tighten the fasteners diagonally to 110 ± 10 Nm (81 ± 7 lb-ft).

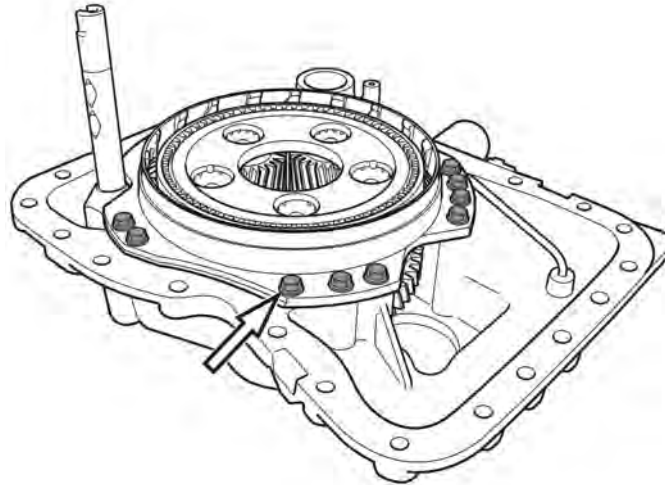

T4021492

- 43 Apply a bead of approved sealant to the housing face as shown.

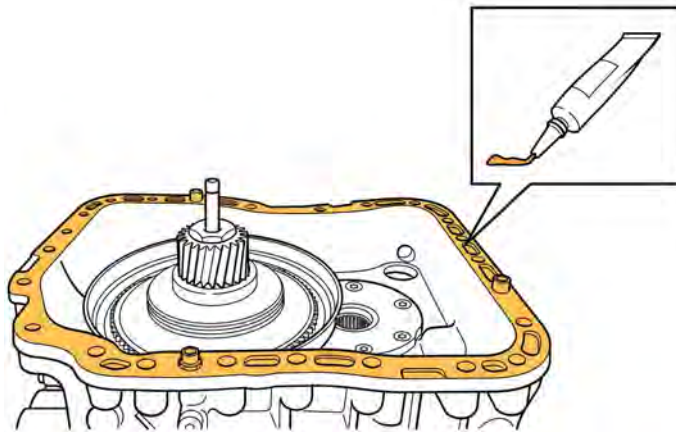

W4089451

- 44 Line up the piston rod and planetary gear. Carefully lower the range housing into the main housing.
- 45 Install the range housing mounting fasteners. Tighten fasteners to 110 ± 10 Nm (81 ± 7 lb-ft).
- 46 Check that the control housing sealing surface is clean. Install a new control housing gasket.

Note: Clean any dirt and corrosion from the alignment dowels in the housing and from the dowel holes in the control housing assembly to aid in reinstallation.

47 Ensure that the split engaging ring is in its rear most position. Ensure that the 2nd/3rd engaging ring is in neutral or middle position and that the reverse gear engaging ring is in its rear most position (Figure 1). Also ensure that the range gear is in high range (Figure 2).

Note: Ensure that the new control housing forks correspond to the position of the engaging rings. If they do not correspond, gently position them by hand.

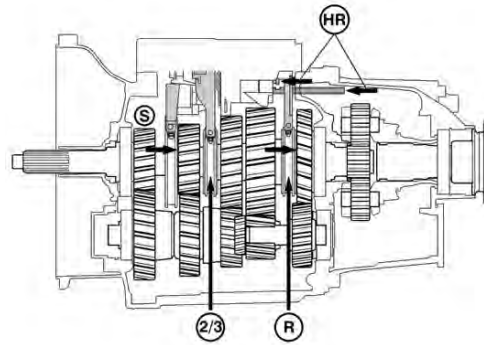

T4021451

Figure 1

HR – High Range

S – Split

2/3 – 2nd/3rd gear in neutral

R – Reverse gear

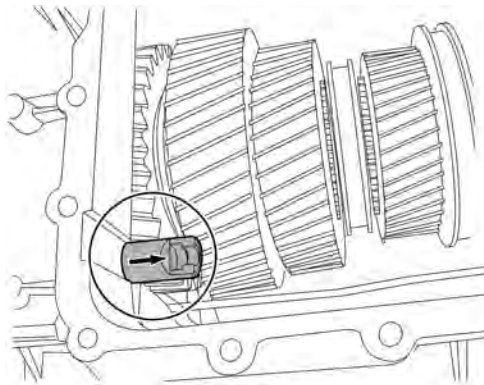

W4002948

Figure 2

48 Ensure that the range servo piston is positioned out 25.4 mm (1 in.) to properly mate with the main housing.

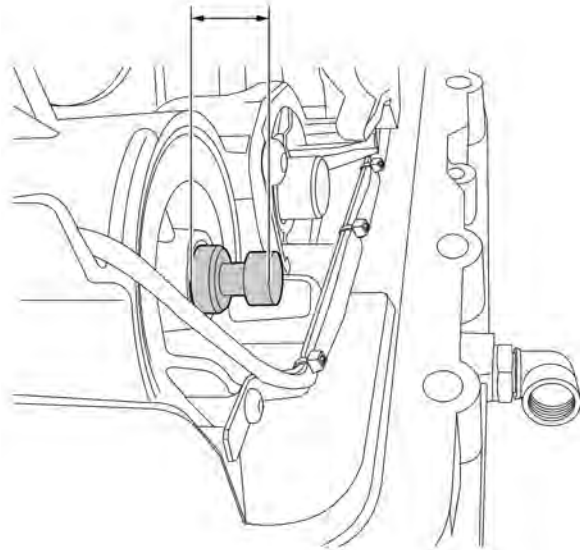

W4002950

49



CAUTION

Always install the alignment pins before installing the control housing to prevent damage to the transmission main shaft speed tone ring and the speed sensor.

Install the alignment pins in the transmission.

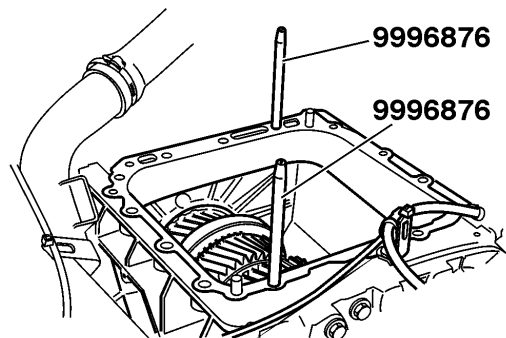

T4018982

50



CAUTION

To avoid component damage gently install the control housing with little more than gentle taps to seat in place. If the control housing does not install easily, remove and check the alignment of components in the gearbox and the control housing assembly. Forcing the control housing can cause unreparable damage and requires a component replacement.

Carefully lower the control housing to avoid damaging the tooth wheel in the transmission. Ensure that the split fork ends up in the correct position in engaging ring. Remove the alignment pins.

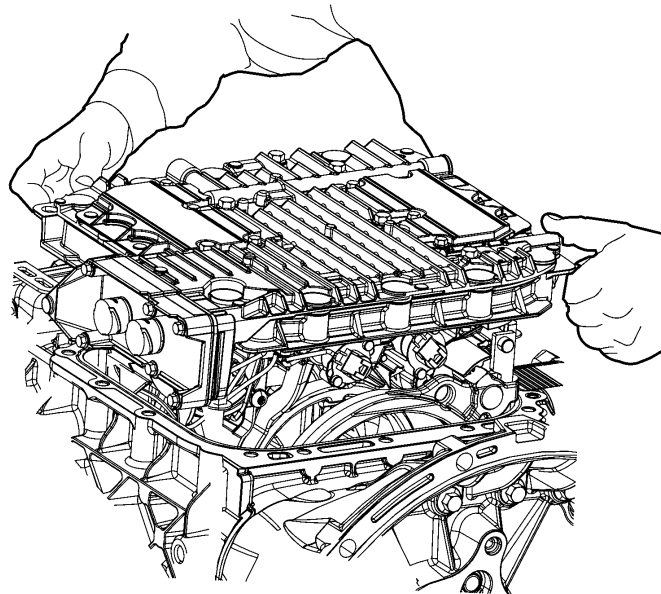

W4002949

51 Installed new solenoid valve seals, an O-ring for the counter-shaft brake and a new upper cover gasket.

Note: Only perform this and the following steps if; the control housing was replace without a new upper cover. If replacing the control housing as a complete assembly proceed to 54.

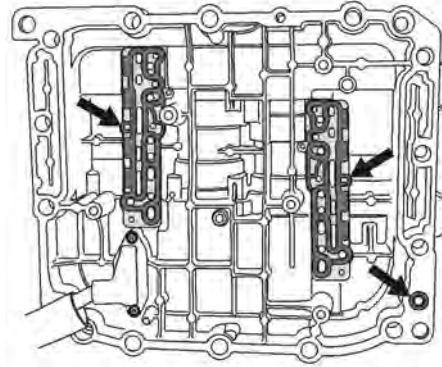

T4020778

52



CAUTION

Electrical components, including the wiring harness inside the transmission control housing, are delicate. Handle with extreme care. Failure to do so may result in damage to components.

Place the new upper cover in position and carefully connect the wiring harness. Lower the upper cover into position.

Note: Do not apply tension or weight to the wiring harness or connector.

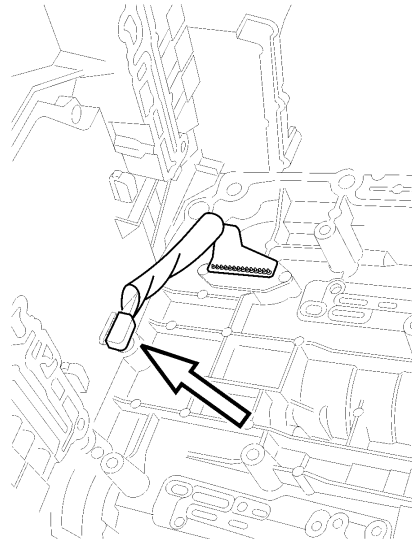

W4002953

53 Install the six upper cover mounting bolts. Tighten fasteners to 24 ± 4 Nm (18 ± 3 ft-lb).

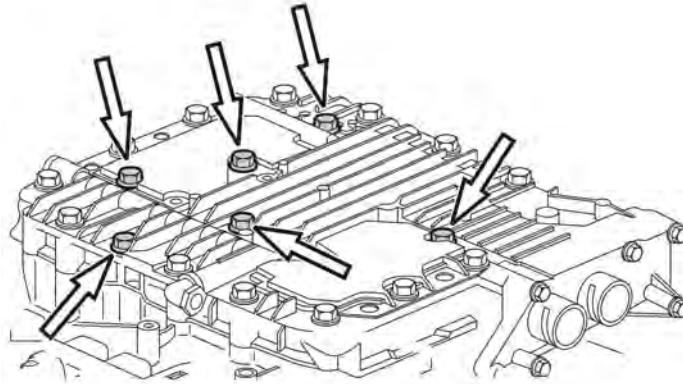

W4002952

54 Install the control housing. Tighten the fasteners to 110 ± 10 Nm (81 ± 7 ft-lb).

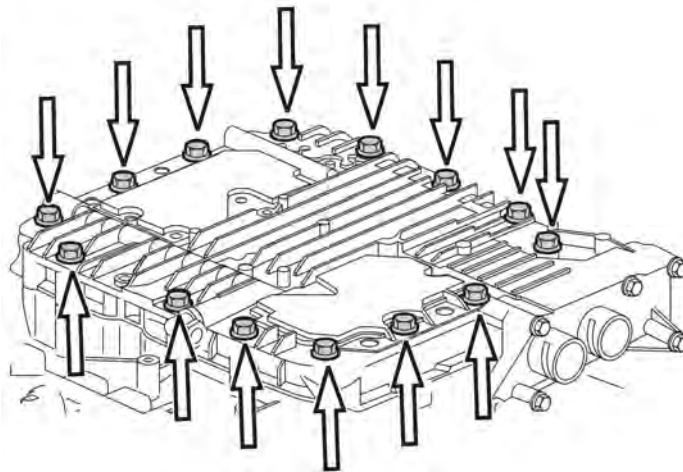

W4002951

55 Connect the clutch control valve air supply tube to the upper control housing fitting.

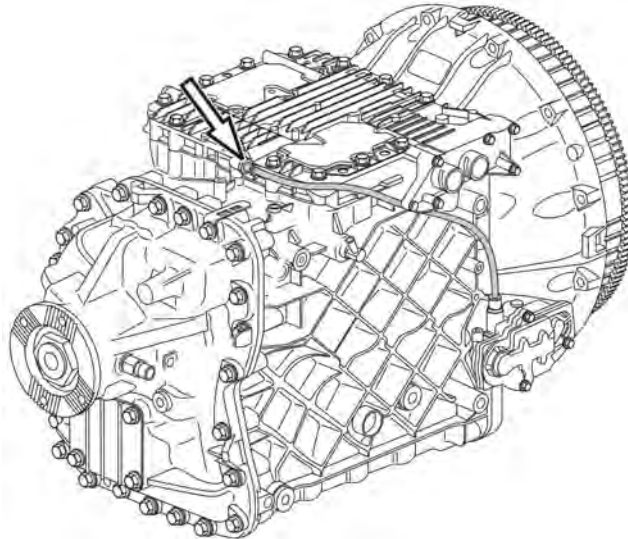

W4002947

56 Install the plunger, spring and plug for the range function. Tighten plug to 55 ± 8 Nm (41 ± 6 lb-ft).

57 Connect the clutch valve wiring connector to the control housing.

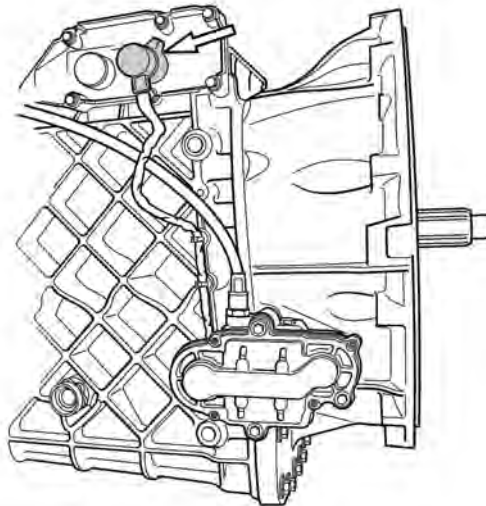

W4002881

58 After the control housing has been installed, use PTT to perform calibration operation 4000-07-04-01 "Gearbox (Gearbox removed)".

Note: If calibration fails, check that the shift fork position sensor values are within the specification ranges. Shift fork values out of range may indicate incorrect assembly of shift forks to engaging rings preventing correct transmission shifting. Perform tests in PTT to check Range cylinder (4320-08-03-02), Split cylinder (4320-08-03-03), Gear selector cylinder 2/3 (4320-08-03-05) and Gear selector cylinder 1/Reverse (4320-08-03-24). Remove control housing and inspect shift fork and engaging ring positions. Repeat the control housing installation.

Note: If software needs to be updated, do NOT program gearbox until after all assembly is complete.

59 To aid transmission installation, remove the service plug on the clutch control valve assembly. Clean around the plug prior to removal to prevent debris from entering the valve. Place a clean shop rag over the open port to prevent debris from entering the valve during installation. Once the installation is complete replace the plug and tighten to 7 ± 2 Nm (5 ± 1 ft-lb).

Note: Failure to perform this step will hamper installation. The transmission will be installed under clutch cylinder spring pressure and will fail to freely slide forward into place against the flywheel housing mating surface.

60 Carefully install the transmission and align to the engine. Loosely install two upper and two lower transmission-to-engine mounting bolts to hold the transmission in place.

Note: Do NOT lubricate the input shaft splines.

Note: The use of an assistant may be necessary to aid during installation.

Note: Rotate the input shaft to align the clutch splines.

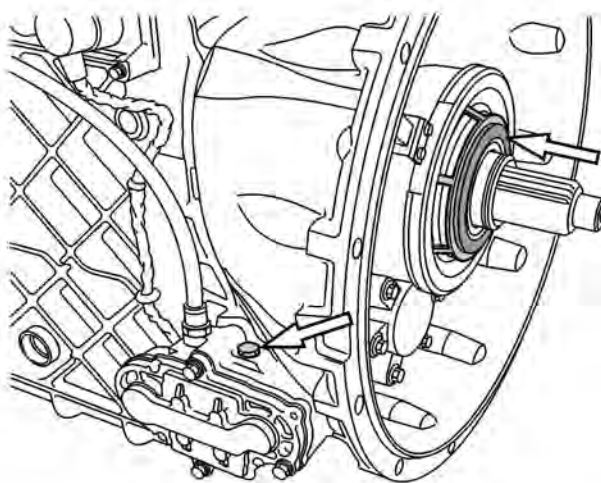

61 Install the remaining transmission-to-engine mounting bolts. Tighten to 92 ± 8 Nm (68 ± 6 ft-lb). Remove the transmission jack.

Note: To aid access, install and tighten the mounting bolts on the top of the clutch housing first. Remove the transmission jack and install the remaining mounting bolts.

62 Position the battery cables and install their mounting bolts.

63 Position the electrical harness and reconnect the control housing, speed sensor and two chassis connectors.

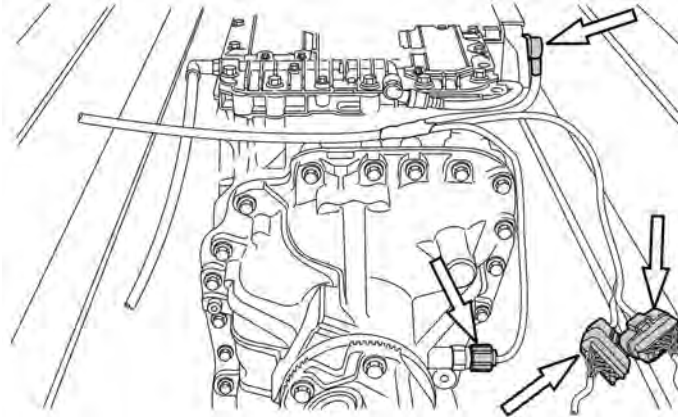

W4002941

64 Install new tie straps to secure the wiring harness to the transmission.

65 Connect the air supply hose at the rear of the transmission.

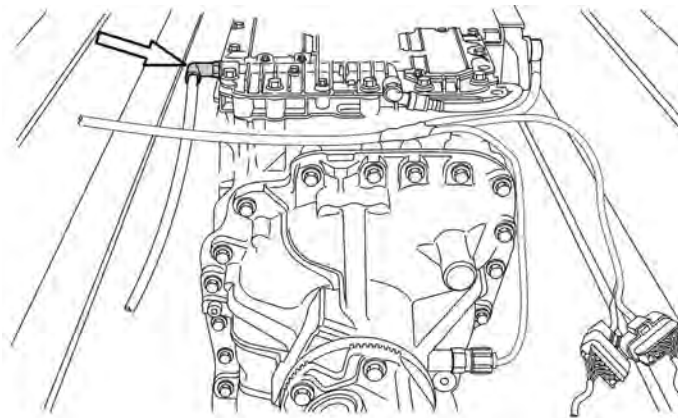

W4002940

66 Connect the transmission oil cooler hoses to the filter housing.

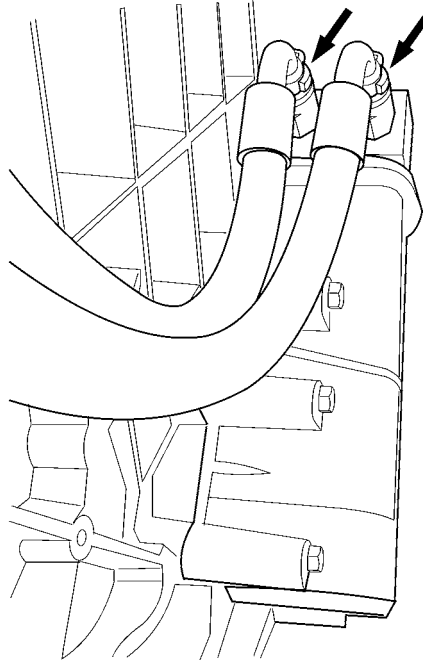

W4002894

67 Install the drive shaft, the universal joint caps and the bolts holding the intermediate bearing to the support bracket if equipped).

Note: It is important to center the rubber insulator in the U-bracket correctly.

* Intermediate Bearing: 105 ± 20 Nm (78 ± 15 ft-lb)

* Universal Joint Caps: 170 ± 15 Nm (125 ± 10 ft-lb)

68 Remove the supporting jack stands and lower the vehicle.

69 Pressurize the air system and check for leaks.

70 Connect all previously removed cables to the negative (ground) battery terminals. Tighten fasteners to 20 ± 2 Nm (15 ± 1.5 ft-lb).

71 Replace the transmission oil filter.

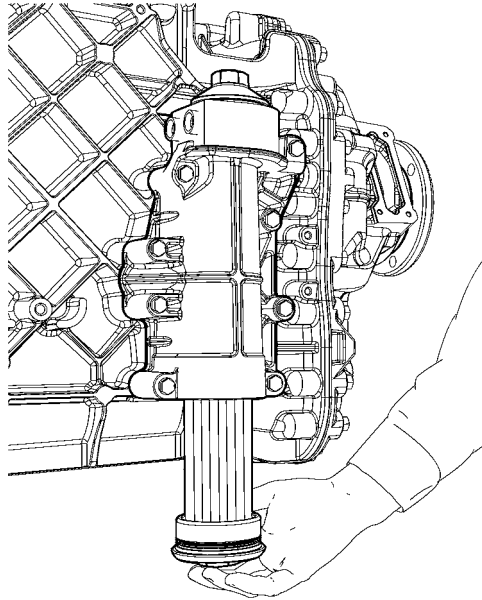

W4002908

72 Fill the transmission with approved transmission oil.

73 Use PTT to check the transmission electronic control unit (TECU) software, current main software is 23084204. If the software is not current, program the TECU. From the Main Menu select Program and then Program Electronic Control Unit 1700-08-03-39. Then click Start. Select Transmission ECU (TECU). Select Program to update the TECU with the latest software.

74 Use PTT to perform calibration operation 4320-07-03-01 "Gearbox, clutch, engagement point".

75 Clear all diagnostic trouble codes (DTC) prior to returning to service.

Reimbursement

This repair may be eligible for reimbursement if a product failure was experienced within time and mileage limits of the applicable Warranty coverage. Reimbursement is obtained via the normal claim handling process.	Reimbursement UCHP	Reimbursement eWarranty
Claim Type (used only when uploading from the Dealer Bus. Sys.)	01	01
Labor Code		
Primary Labor Code	4319-16-09-01 7.7 hrs.	3231N-43-80 7.7 hrs.
Causal Part	21480996	21480996

MACK Trucks reserves the right to make any changes in design or to make additions to or upon its products without incurring any obligations to install the same on vehicles previously built.