



Countries: CANADA, TAIWAN, UNITED STATES, MEXICO, GUAM, KOREA, SOUTH KOREA
Availability: ISIS, FleetSIS, NotSIR
Major System: ELECTRICAL SYSTEM
Current Language: English
Other Languages: [Français](#), [Español](#)
Viewed: 13213

Document ID: IK0800284
Revision: 21
Created: 5/16/2011
Last Modified: 11/20/2017
Author: Charles Schroeder

[Less Info](#)

Hide Details

Coding Information

| | | | | | | | |
|----------------------|-------------------------------|--|-----------------------------|------------------|-----------------------------|---------------------------|------------------------------|
| Copy Link | Copy Relative Link | Bookmark View My Bookmarks | Add to Favorites | Print | Provide Feedback | Helpful 131 | Not Helpful 45 |
|----------------------|-------------------------------|--|-----------------------------|------------------|-----------------------------|---------------------------|------------------------------|

Title: Ambient Air Temperature (AAT) Sensor Faults/Location/Diagnostics

Applies To: Navistar N13 Engines and Cummins ISX Engines Cummins ISB, N9 and N10

Change Log

Dealers: Please refer to the change log text box below for recent changes to this article:

11/20/2017 - Updated diagnostic software to Navistar Engine Diagnostics™.
 03/13/2017 - Added link to IK1200886 - Relocation of AAT Sensor to Mirror due to Fault Codes and Air Temp Flow Issues with Aftermarket Bumpers as this relocation changes the wiring for the sensor.
 02/24/2017 - Updated to correct author
 08/12/2015 - Removed 2010 MaxxForce 11/13. Please refer to updated manual 0000001741.
 06/22/2015 - Author updated for feedback purposes.
 04/22/2015 - Add TranStar model.

Table of Contents

Click on the items below to jump to each section:

| | |
|--|--|
| Description | Cluster Circuit Diagrams |
| Symptom(s) | Sensor Location - Big Bore Engines |
| Special Tool(s) / Software | Sensor Location - Medium Duty Engines |
| Service Parts Information | Engine Sensor Circuit Diagrams (See NOTES below) |
| Engine Sensor Troubleshooting | Warranty Coding / SRT |
| Cluster Sensor Troubleshooting | Other Resources |

Description

The Ambient Air Temperature Sensor provides information to the Engine and / or Cluster based on vehicle model and engine application. The number of sensors used and location of each sensor also varies based on vehicle model and engine application. This article will help outline the different installation options for this sensor.

NOTE:

On all SCR vehicles, the cluster will receive AAT Sensor data via J1939, 0595BTH, reducing the number of aat sensors from 2 to 1 on each SCR vehicle.

NOTE:

If unable to find AAT sensor in the mirror, check service portal for previous repairs. We have seen cases where the mirror head was replaced and the sensor was not reinstalled properly.

NOTE:

If the sensor was relocated the mirror the wiring for the sensor will not match the schematic based on the vehicles build date. Please refer to [IK1200886 - Relocation of AAT Sensor to Mirror due to Fault codes and Air Temp Flow Issues with Aftermarket Bumpers](#) for more information.

([Return to Top](#))

Symptom(s)

Diagnostic Trouble Code(s) & Dashboard Indicator Light(s):

| DTC / Light | Cummins Fault | Description |
|---------------|---------------|--|
| SPN 171 FMI 2 | 2389 | AAT signal does not agree with other sensors |
| SPN 171 FMI 3 | 249 | AAT signal out of range HIGH |
| SPN 171 FMI 4 | 256 | AAT signal out of range LOW |

Customer Observations or Concerns:

- MIL
- Engine performance may be reduced
- Unable to perform regen

([Return to Top](#))

Special Tool(s) / Software

| Tool Description | Tool Number | Comments | Instructions |
|------------------------------|-------------|------------------|--------------|
| Navistar Engine Diagnostics™ | | EZ-Tech Software | |
| Cummins INSITE | | EZ-Tech Software | |

([Return to Top](#))

Service Parts Information

| Kit Description | Part Number | Quantity Required | Notes |
|-----------------------------|-------------|-------------------|-------|
| Sender, Ambient Temperature | 3561562C1 | 1 | |

([Return to Top](#))

Engine Sensor Troubleshooting

There are two ambient temperature sensors. The sensor located behind the cab along the left frame rail is the sensor the engine uses. To confirm this, unplug the sensor and observe the cluster LCD display, if the reading stays the same, the correct sensor is unplugged. There is also a sensor located at the front of the chassis that the gauge cluster uses for the temp display.

This article begins and discusses the Engine AAT Sensor, prior to and first. After August 23, 2013, Some SCR engines have the Engine AAT sensor mounted in the driver side mirror head and alternatively the sensor could be mounted to the horn bracket. The location depends on build date.

2013 Navistar N13 Diagnostics

FAULT CODE 171-2 ONLY

| Step | Action | Decision |
|------|---|------------------|
| 1 | Update ECM Calibration <ul style="list-style-type: none"> • Check Calibration Scorecard on Service Portal • Use Electronic Service Tool (EST) to clear the fault code. This code will be corrected with the new ECM Calibration | Repair Complete. |

2010 MaxxForce 11/13L Diagnostics

FAULT CODE 171-2 ONLY

NOTE: If the ECM is setting/logging code 171-2 and the sensor tests good **DO NOT** replace the sensor, there is a new calibration available as of March 7, 2014 for EGR engines.

| Step | Action | Decision |
|------|---|------------------|
| 1 | Update ECM Calibration <ul style="list-style-type: none"> • Check Calibration Scorecard on Service Portal • Use Electronic Service Tool (EST) to clear the fault code. This code will be corrected with the new ECM Calibration | Repair Complete. |

All Engines with Ambient Air Temp Sensor

FAULT CODE(s) 171-3 and 171-4 ONLY

Refer to the appropriate Engine or Chassis wiring schematic manual to ensure you are on the proper ECM connector and terminal.

| Step | Action | Decision |
|------|--|------------------------|
| 1 | Measure Resistance of the sensor and compare to the chart shown in Figure 1 <ul style="list-style-type: none"> • SPEC: Based on Ambient Temp Is resistance measurement in spec? | Yes: Go to step 2 |
| | | No: Replace AAT Sensor |

| Step | Action | Decision |
|------|---|---|
| 2 | Measure voltage between ambient temperature sensor connector cavity A and GND <ul style="list-style-type: none"> • SPEC: 5 +/- 0.5 Vdc Is voltage measurement in spec? | Yes: Go to step 3 |
| | | No: Inspect wire from ECM to AAT sensor pin A for open or short |

| Step | Action | Decision |
|------|--|---|
| 3 | Measure voltage between ambient temperature sensor connector cavity A and cavity B <ul style="list-style-type: none"> • SPEC: 5 +/- 0.5 Vdc Is voltage measurement in spec? | Yes: Restore back to operational condition and retest for fault code 171-3 or 171-4 |
| | | No: Inspect ZVR wire from ECM to AAT sensor pin B for open or short |

([Return to Top](#))

Cluster Sensor Troubleshooting

FAULT CODE(s) 171-3 and 171-4 ONLY

The instrument cluster, connector 1501 pin 9, sends a 5-volt source to the temperature sensor. As the voltage goes across the temperature sensor it decreases, the amount of voltage drop depends on outside temperature. The reduced voltage then returns to the instrument cluster on pin 8 of connector 1500. The instrument cluster turns the received signal into to the temperature shown on the display.

NOTE: The Electronic Gage Cluster display will replace temperature reading with two dashes (- -) if a fault is present with the Ambient Temperature Sensor circuit.

| | |
|--|--|
| | |
|--|--|

| Step | Action | Decision |
|------|--|------------------------|
| 1 | Measure Resistance of the sensor and compare to the chart shown in Figure 1 • SPEC: Based on Ambient Temp Is resistance measurement in spec? | Yes: Go to step 2 |
| | | No: Replace AAT Sensor |

| Step | Action | Decision |
|------|---|--|
| 2 | Measure voltage between ambient temperature sensor connector cavity A and GND • SPEC: 5 +/- 0.5 Vdc Is voltage measurement in spec? | Yes: Go to step 3 |
| | | No: Inspect wire from cluster 1501-9 to AAT sensor pin A for open or short |

| Step | Action | Decision |
|------|--|---|
| 3 | Measure voltage between ambient temperature sensor connector cavity A and cavity B • SPEC: 5 +/- 0.5 Vdc Is voltage measurement in spec? | Yes: Restore back to operational condition and retest for fault code 171-3 or 171-4 |
| | | No: Inspect ZVR wire from cluster 1500-8 to AAT sensor pin B for open or short |

AAT Sensor Temperature VS. Resistance Chart

| Temp | Temp | R Nom | R Min | R Max | +/- (%) Tol Nom |
|------|------|-----------|-------------|-------------|-----------------|
| -76F | -60C | 1,410,910 | 1,267,349.9 | 1,554,470.1 | 10.175 |
| -58F | -50C | 671,960 | 611,483.6 | 732,436.4 | 9 |
| -40F | -40C | 336,000 | 310,464 | 361,536 | 7.6 |
| -22F | -30C | 177,000 | 165,185.3 | 188,814.8 | 6.675 |
| -4F | -20C | 97,060 | 91,382 | 102,738 | 5.85 |
| 14F | -10C | 55,319 | 52,483.9 | 58,154.1 | 5.125 |
| 32F | 0C | 32,654 | 31,225.4 | 34,082.6 | 4.375 |

| TEMP °F | TEMP °C | R NOM | R MIN | R MAX | ± (%) TOL NOM |
|---------|---------|---------|-------------|-------------|---------------|
| -76°F | -60°C | 1410910 | 1,267,349.9 | 1,554,470.1 | 10.175 |
| -58°F | -50°C | 671960 | 611,483.6 | 732,436.4 | 9 |
| -40°F | -40°C | 336000 | 310,464.0 | 361,536.0 | 7.6 |
| -22 °F | -30°C | 177000 | 165,185.3 | 188,814.8 | 6.675 |
| -4 °F | -20°C | 97060 | 91,382.0 | 102,738.0 | 5.85 |
| 14°F | -10°C | 55319 | 52,483.9 | 58,154.1 | 5.125 |
| 32°F | 00°C | 32654 | 31,225.4 | 34,082.6 | 4.375 |
| 50°F | 10°C | 19903 | 19,141.7 | 20,664.3 | 3.825 |
| 68°F | 20°C | 12493 | 12,058.9 | 12,927.1 | 3.475 |
| 77 °F | 25°C | 10,000 | 9,662.0 | 10,338.0 | 3.38 |
| 86°F | 30°C | 8056 | 7,776.1 | 8,335.9 | 3.475 |
| 104°F | 40°C | 5327 | 5,131.2 | 5,522.8 | 3.675 |
| 122°F | 50°C | 3603 | 3,463.4 | 3,742.6 | 3.875 |
| 140°F | 60°C | 2488 | 2,382.3 | 2,593.7 | 4.25 |
| 158°F | 70°C | 1752 | 1,673.2 | 1,830.8 | 4.5 |
| 176°F | 80°C | 1255 | 1,191.9 | 1,318.1 | 5.025 |
| 194°F | 90°C | 915 | 866.3 | 963.7 | 5.325 |
| 212°F | 100°C | 680 | 639.2 | 720.8 | 6 |
| 230°F | 110°C | 517 | 484.2 | 549.8 | 6.35 |
| 248°F | 120°C | 390 | 363.9 | 416.1 | 6.7 |
| 266°F | 130°C | 300 | 277.3 | 322.7 | 7.575 |
| 284°F | 140°C | 235 | 216.3 | 253.7 | 7.975 |
| 302°F | 150°C | 185 | 168.6 | 201.4 | 8.85 |

- Return to [Troubleshooting Engine Sensor](#)
- Return to [Cluster Sensor Troubleshooting](#)

([Return to Top](#))

Cluster Circuit Diagram(s)

IMPORTANT: Due to variations during vehicle production, be sure to select the most current wiring schematic manual, specific to the year and model of the vehicle being serviced.

- [ProStar / LoneStar wiring for Cab Sensor](#)
- [ProStar / LoneStar wiring for Cab Sensor with Front Axle Load Sensor](#)
- [HPV wiring for Cab Sensor](#)
- [HPV wiring for Cab Sensor with Front Axle Load Sensor](#)
- [TerraStar wiring for Cab Sensor](#)

The Cab Temperature Sensor is typically mounted near the front bumper or on the cooling package. If the sensor cannot be found verify the wiring to the gauge cluster is present or that the outside air temp monitor feature as ordered on the truck.

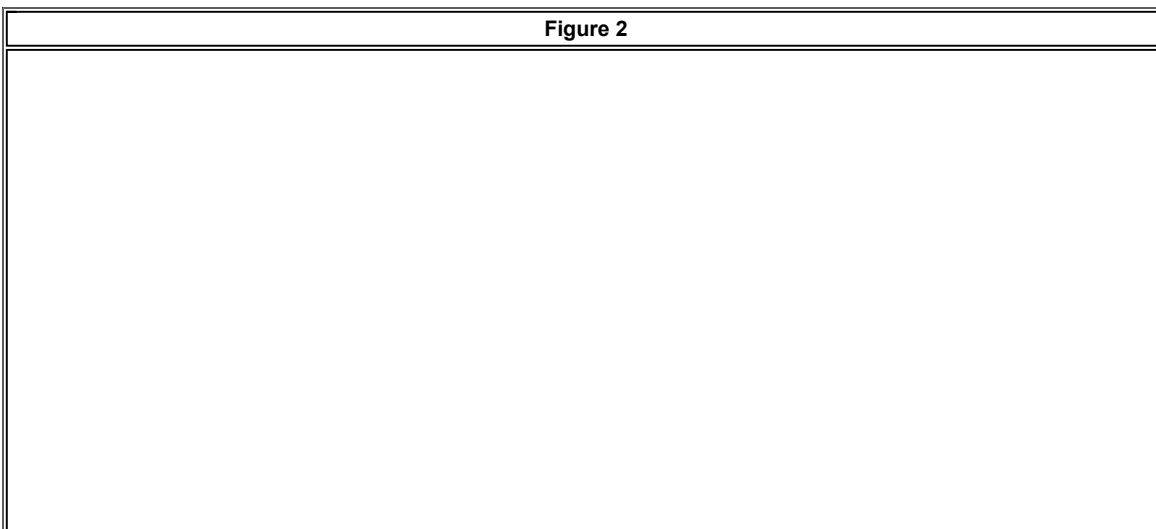

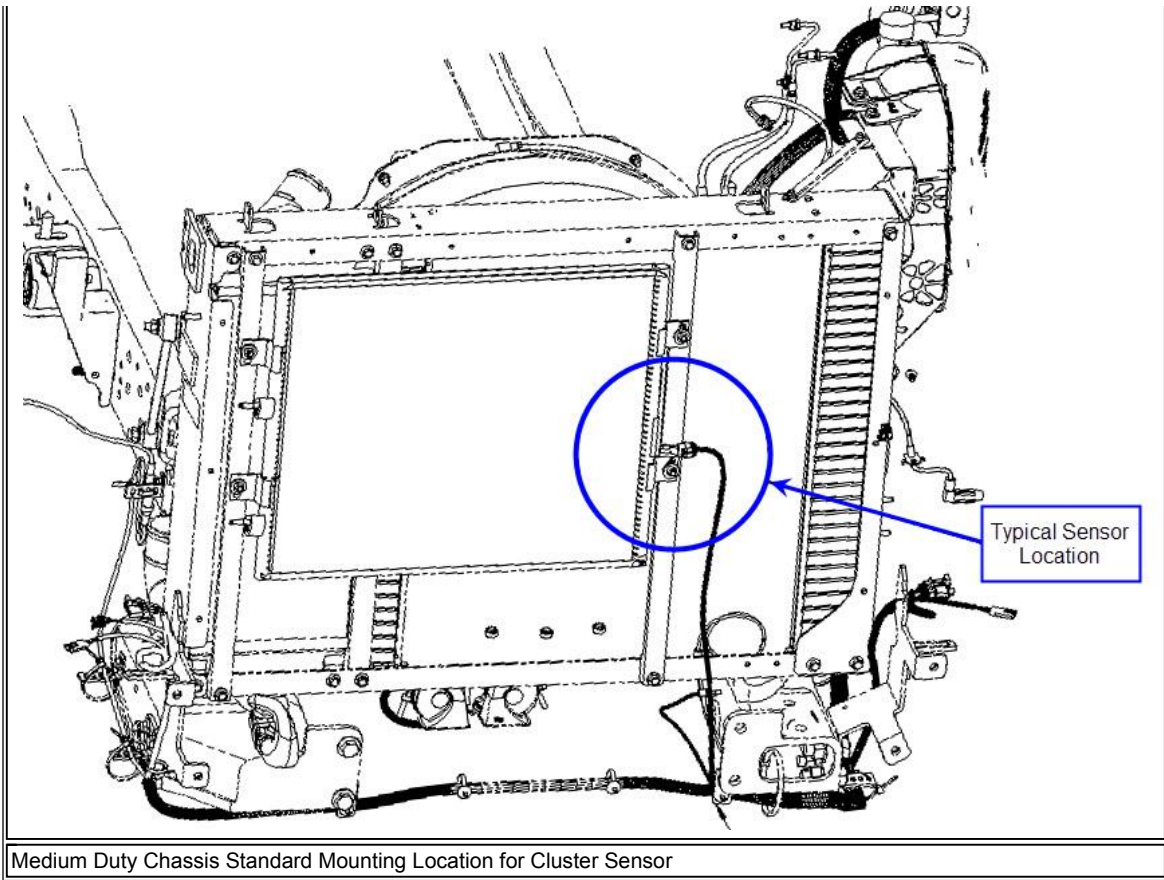
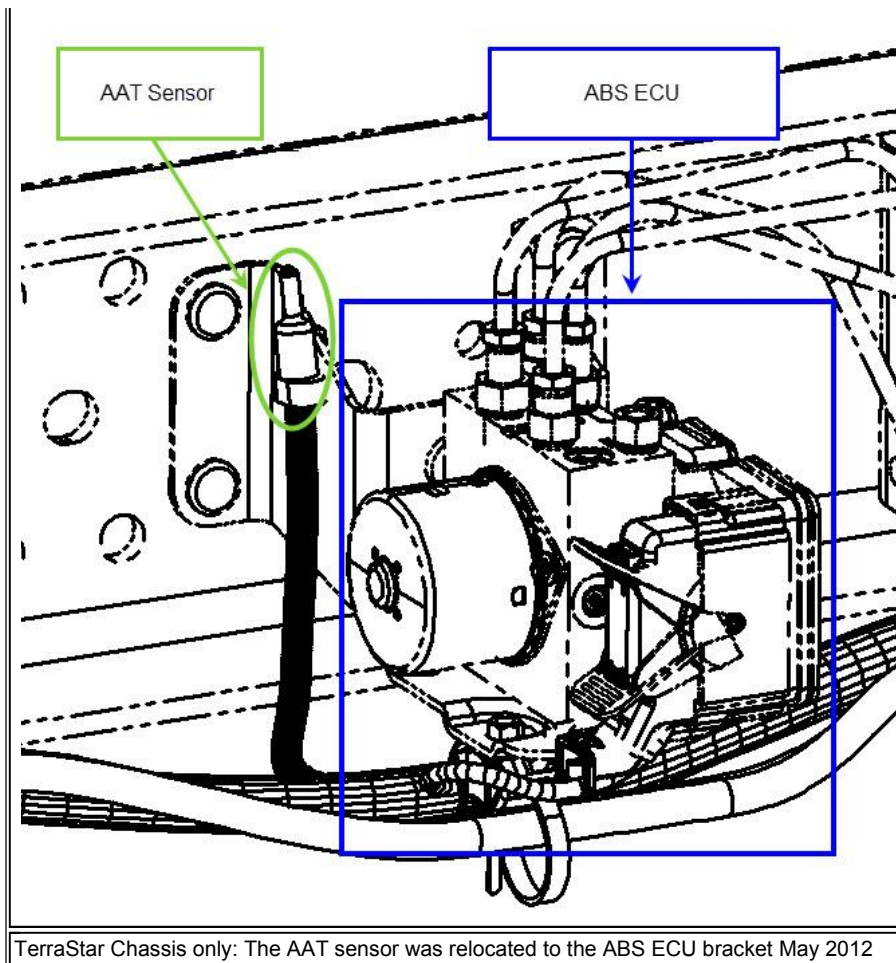

Figure 3



([Return to Top](#))

Sensor Location - Big Bore Engines

Big Bore Pre-SCR Engines and SCR Engine prior to August 2013:

The engine sensor is located on the left frame rail midway between the back of cab and front drive axle, or near the front drive axle. The two photos below show both possible mounting locations (*Figure 4 and Figure 5*).

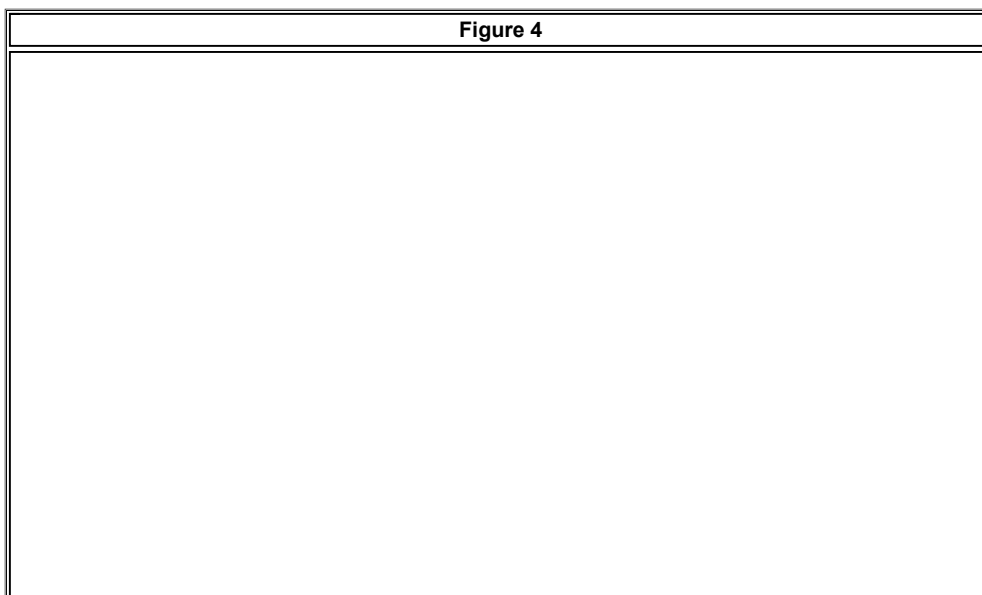
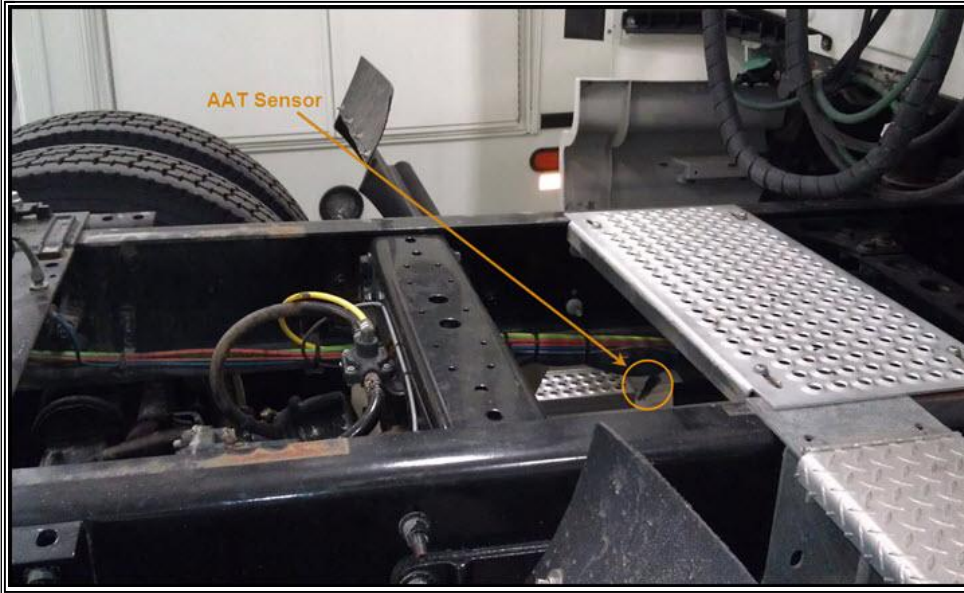
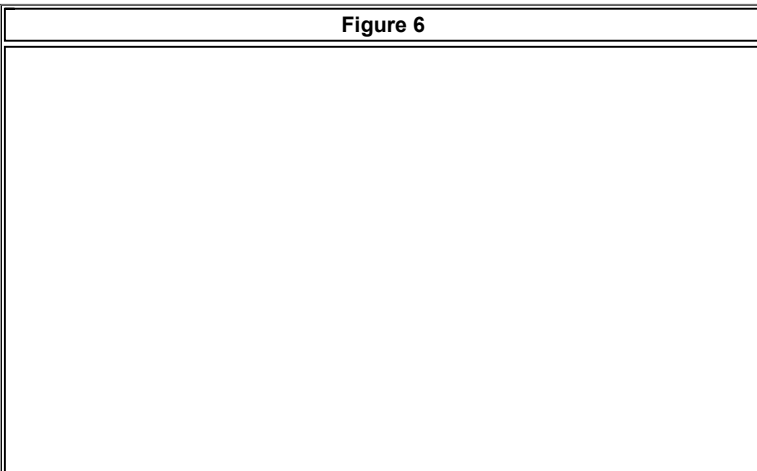



Figure 5



Big Bore Post August 2013 build w/SCR engine, driver's side mirror head (Figure 6):





ISX15 and N13 Alternate Location (Figure 7):

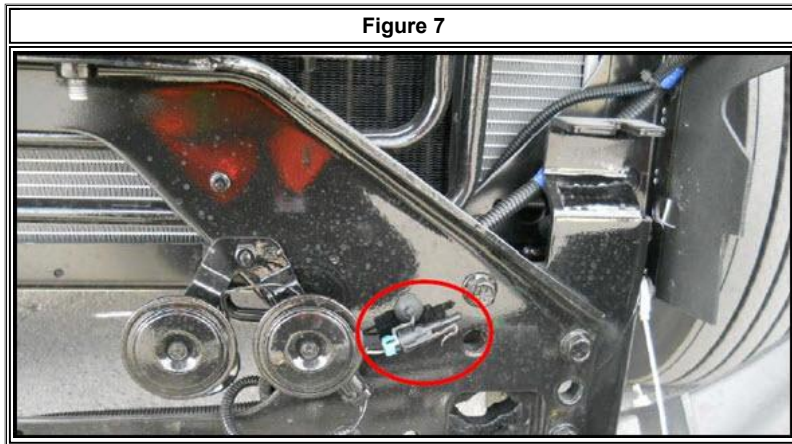

ISX15 and N13 Alternate Location PayStar / 9900i (Figure 8):

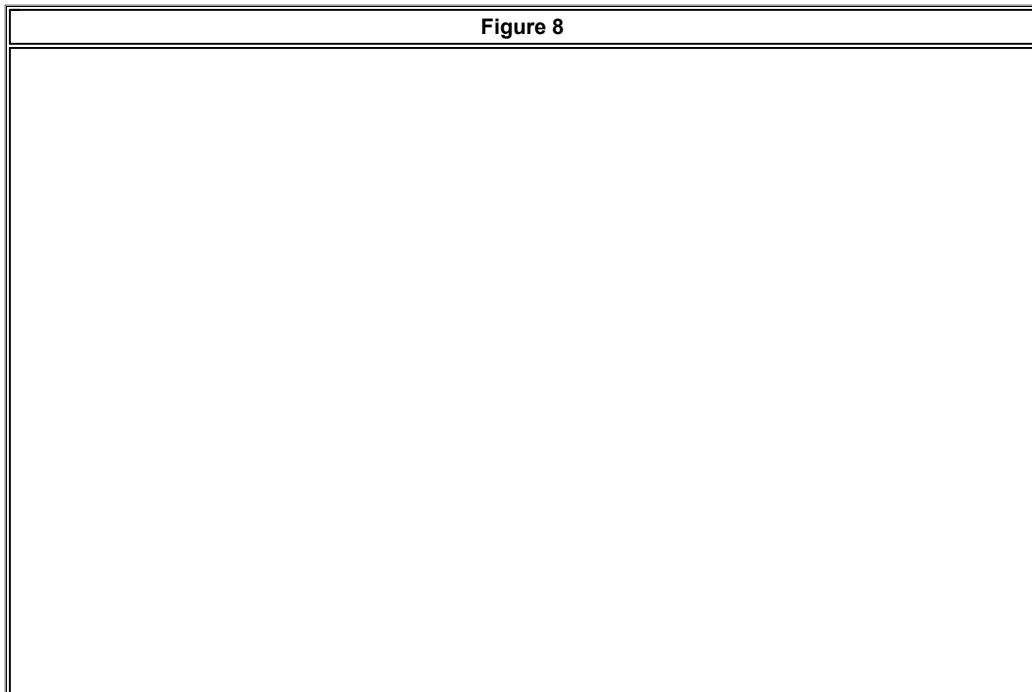

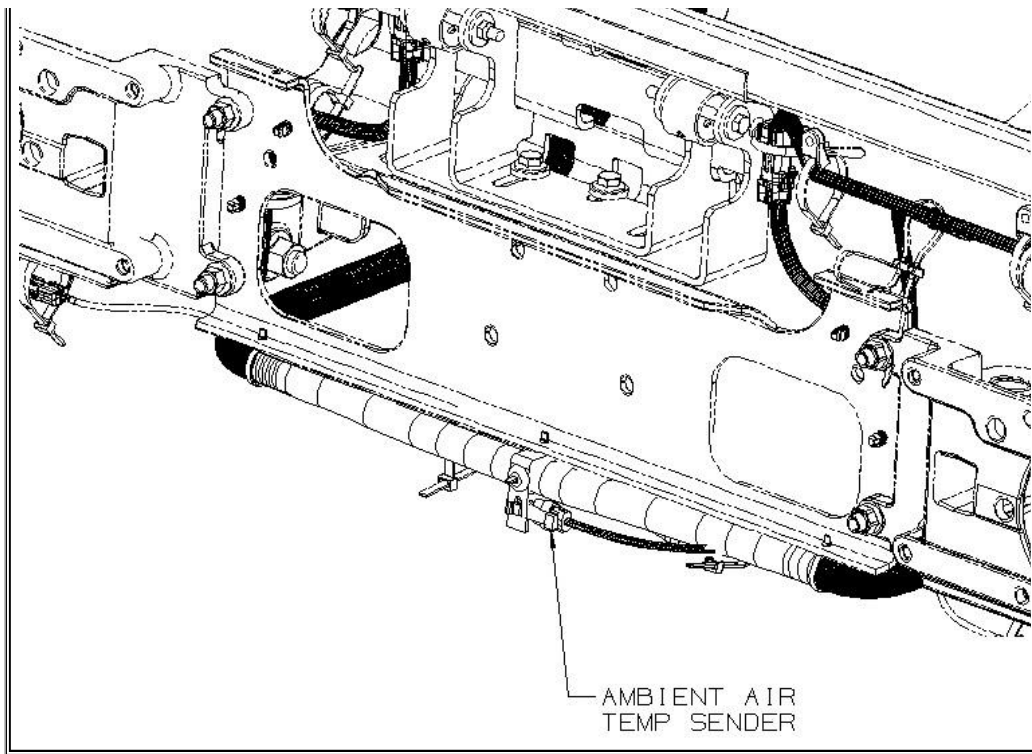

[\(Return to Top \)](#)

Sensor Location - Medium Duty Engines

N9/10 and ISB engine platforms moved the Engine AAT to the driver mirror on August 8, 2014 (*Figure 9*):

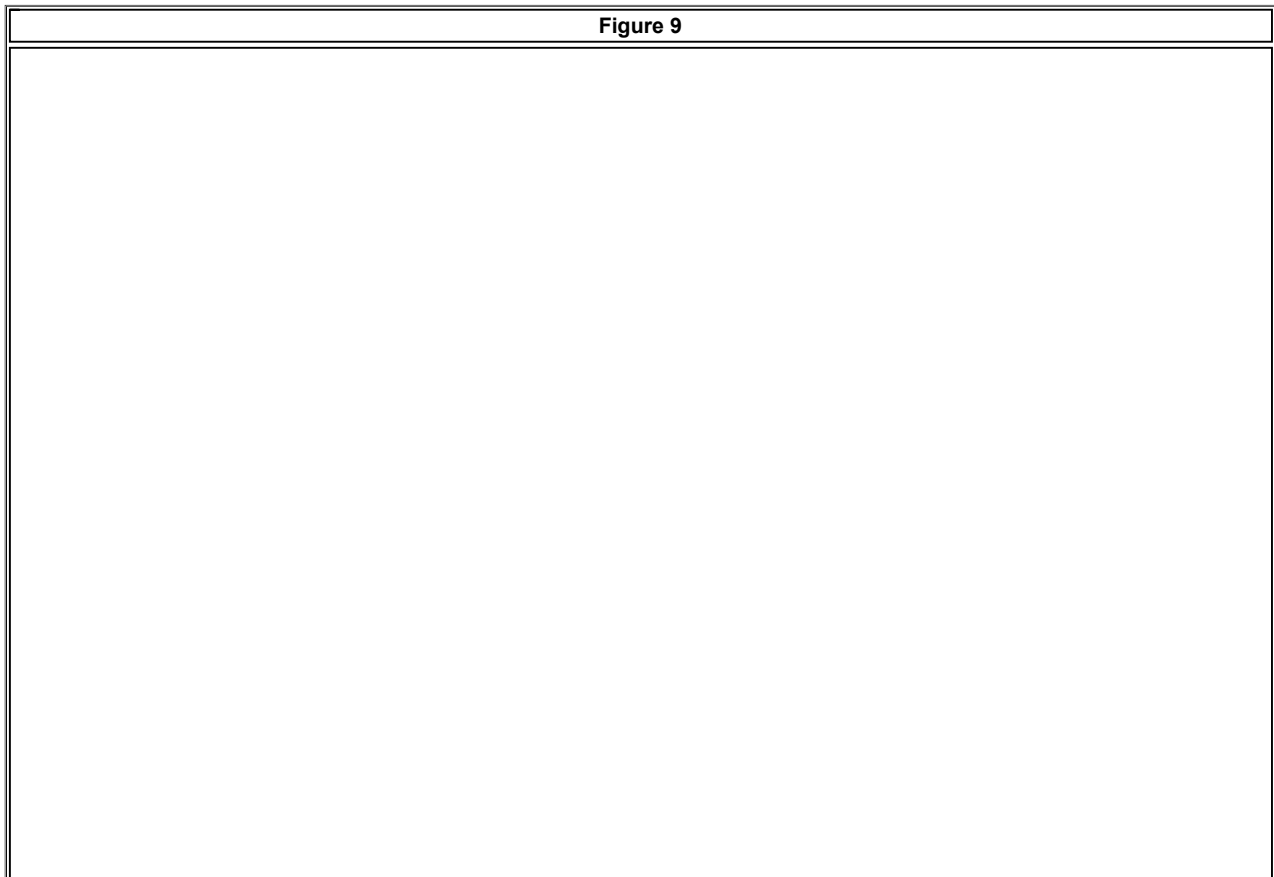

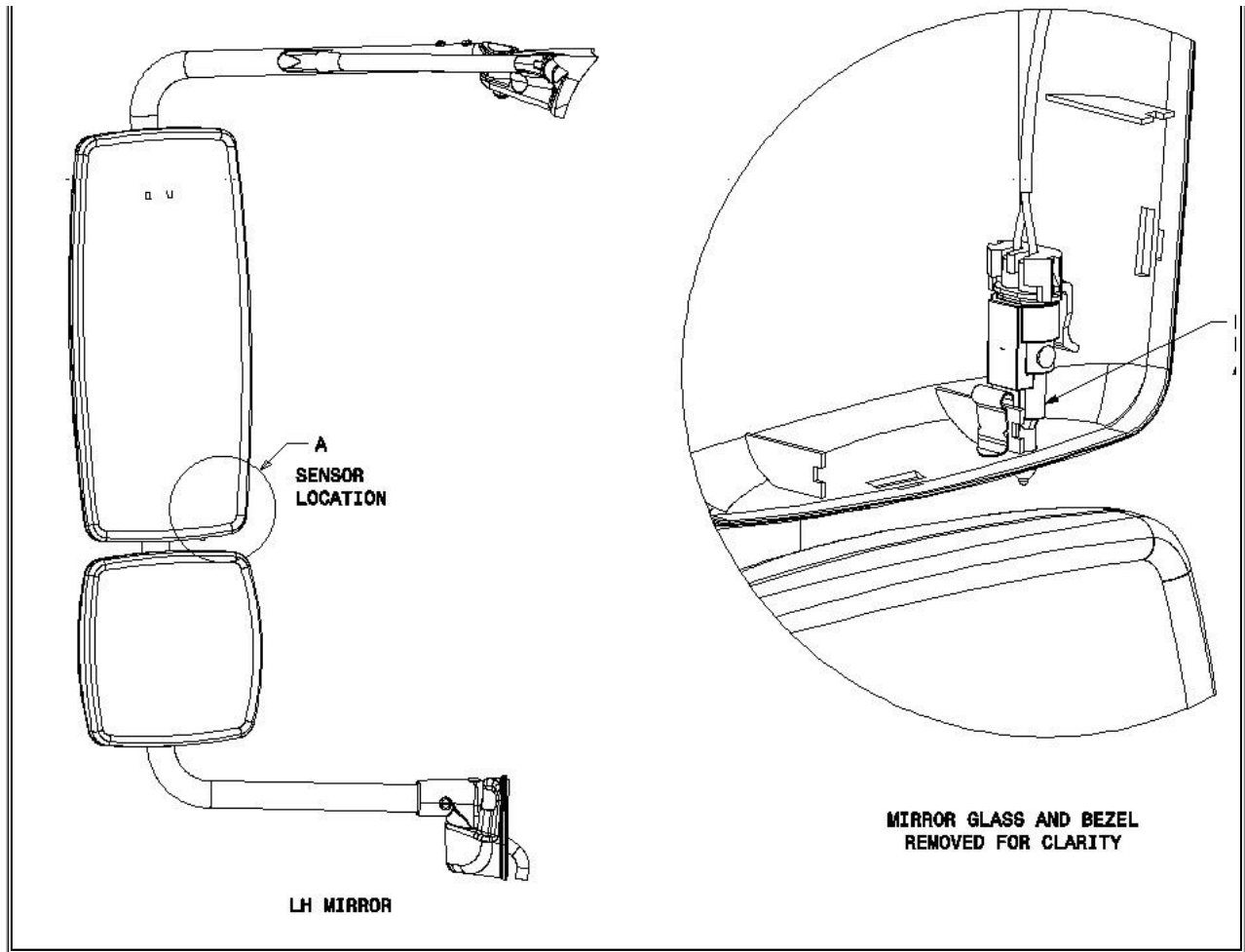

Location prior to August 8, 2014 on CE Bus

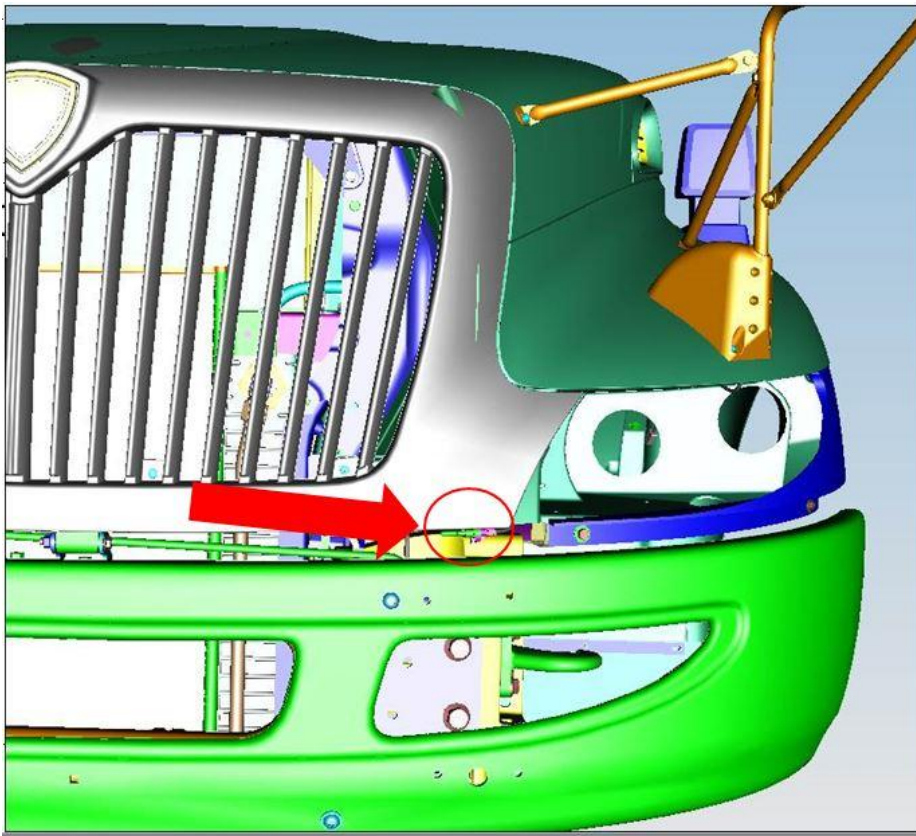

[\(Return to Top \)](#)

Engine Sensor Circuit Diagram(s)

| | |
|--|---|
| N13 ProStar built after May 2014 | N13 ProStar built prior to May 2014 / MaxxForce 11/13 |
| N13 PayStar / 9900i built after May 2014 | N13 PayStar / 9900i built prior to May 2014 / MaxxForce 11/13 |
| ISX15 ProStar built after May 2014 | ISX15 ProStar built prior to May 2014 |
| ISX15 PayStar / 9900i built after May 2014 | ISX15 PayStar / 9900i built prior to May 2014 |
| ISB built after May 2014 | ISB built prior to May 2014 |
| N9/N10 built after May 2014 | N9/N10 built prior to May 2014 |

[\(Return to Top \)](#)

Warranty Coding / SRT

Warranty Claim Coding:

| | |
|---------------|-----------------------------------|
| Group: | 12000 - Engines |
| Noun: | 160 - Sender, Ambient Temperature |

Warranty Claim Coding:

| | |
|---------------|------------------------------------|
| Group: | 08960 - Miscellaneous (Electrical) |
| Noun: | 784 - Thermometer, Electronic |

Standard Repair Time(s):

| Step | Description | Chassis | Engine | SRT | Hours |
|------|---|------------|-------------|---------------------------|-------|
| 1 | Ambient Air Temperature Sensor, Replace | ProStar | Cummins ISX | R08-8160S | 0.3 |
| 1 | Air Temperature Display Sensor, Replace | All Models | | A08-3240 | 0.5 |

Claim SRT Example:

Claim Comment Suggestion:

Special Requirement(s):

([Return to Top](#))

Other Resource(s)

- [IK0800369](#) - 2006-2009 Cummins Active Fault 249 / 256 Ambient Air Temperature Sensor 1 Circuit

([Return to Top](#))

 Hide Details

Feedback Information

Viewed: 13212

Helpful: 131

Not Helpful: 45

No Feedback Found

Copyright © 2017 Navistar, Inc.