

Instrument Cluster, Reprogramming (MID  
140)  
VN, VHD, VAH  
I-Shift Transmission

## **SP 381-048, Instrument Cluster, Reprogramming (MID 140)**

**(November 2017)**

On Certain Volvo Trucks with the I-Shift transmission and the secondary gauge pack with engine and transmission temperature gauges, the transmission temperature gauge may not function. This is due to a software issue. To correct this issue follow the procedure below:

## Decommissioning the Truck for Repair

You must read and understand the precautions and guidelines in Service Information, group 30, "General Safety Practices, Electrical" before performing this procedure. If you are not properly trained and certified in this procedure, ask your supervisor for training before you perform it.

**NOTE:** Information is subject to change without notice. Illustrations are used for reference only and can differ slightly from the actual vehicle being serviced. However, key components addressed in this information are represented as accurately as possible.

- 1 Park the vehicle on a flat and level surface.
- 2 Apply the parking brake.
- 3 Place the transmission in neutral or park.
- 4 Install the wheel chocks.

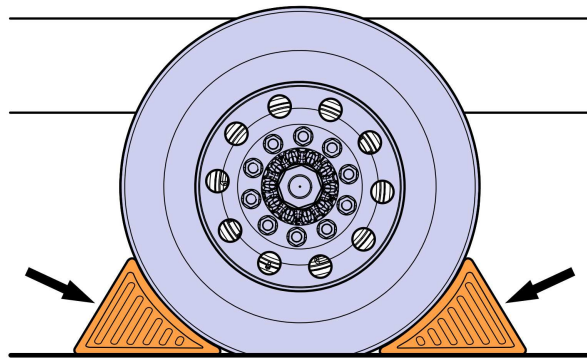

W7086748

## Instrument Cluster, Reprogramming Procedure

- 1 Connect Premium Tech Tool to the vehicle.
- 2 Run Accessory Kit 85150457.
- 3 Program the instrument cluster (MID140)

## Commissioning the Truck for Operation

- 1 Remove the wheel chocks.

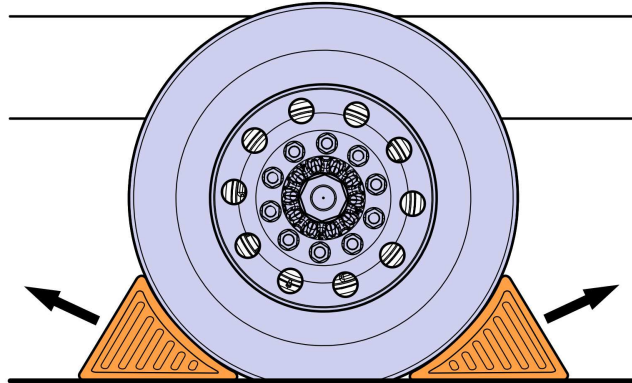

W7086759

### Reimbursement

<b>This repair is covered by an authorized Service Program. Reimbursement is obtained via the normal claim handling process.</b>	<b>UCHP Reimbursement</b>
<b>Claim Type (used only when uploading from the Dealer Bus. Sys.)</b>	B
<b>Recall Status</b>	
Vehicle inspected, repair not required	
Vehicle repaired per instruction	
<b>Labor Code</b>	
Primary Labor Code ( Instrument Cluster, Reprogramming (MID 140))	3811-22-09-01 0.3 hrs
Take to take charge and determine campaign status	1700-16-01-01 0.3 hrs
<b>Causal Part</b>	21724401
<b>SCC Code</b>	S7252
<b>Authorization Number</b>	NA
<b>Expiration Date</b>	November 30, 2018

**Note:** Take Charge Time is not included in the Labor Code for this operation. Take charge may be eligible but can only be used once per repair visit. If vehicle is having other warranty repairs performed, take charge should be charged to the warranty repair, otherwise take charge can be charged to this service program.