

Coolant Hose, EGR Cooler, Replacement D16H, D16J VN

SP 293-027, Coolant Hose, EGR Cooler, Replacement

(June 2014)

Volvo Trucks has authorized replacement of the EGR cooler coolant return hose on vehicles built between 01/01/2010 and 05/16/2014 with VOLVO D16H and D16J engines. Approximately 1657 vehicles are involved in this campaign. The EGR cooler coolant return hose must be changed on all vehicles involved in this campaign. Before proceeding, verify campaign eligibility by checking Service Program status in eWarranty.

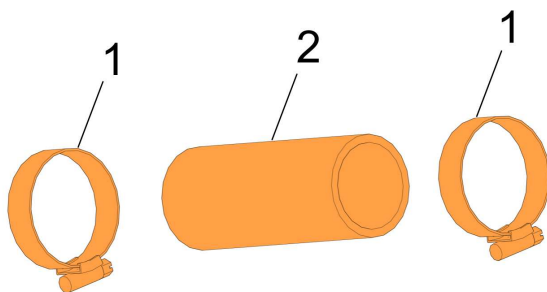

W2091408

Parts List

Item Number	Description	Part Number	Quantity
1	Hose Clamp	961671	2
2	Hose	22387751	1

Procedure

You must read and understand the precautions and guidelines in Service Information, Function Group 20, Engine Safety Practices, before performing this procedure. If you are not properly trained and certified in this procedure, ask your supervisor for training before you perform it.

- 1 Secure the vehicle for service by parking it on a flat level surface, applying the parking brake, chocking the rear wheels, and placing the transmission in neutral or park.
- 2 Disconnect all cables from the negative (ground) battery terminals to prevent personal injury from electrical shock and prevent damage to electrical components
- 3 Raise hood.
- 4 Drain the coolant from the radiator and engine using the coolant extractor (DBT2V700).
Note: An alternate method is to connect the drain hose (9996049) to the drain fitting and drain the coolant.
- 5 Remove the fastener and P-clamp securing the EGR cooler coolant return assembly to the support bracket. Remove the fasteners and support bracket.

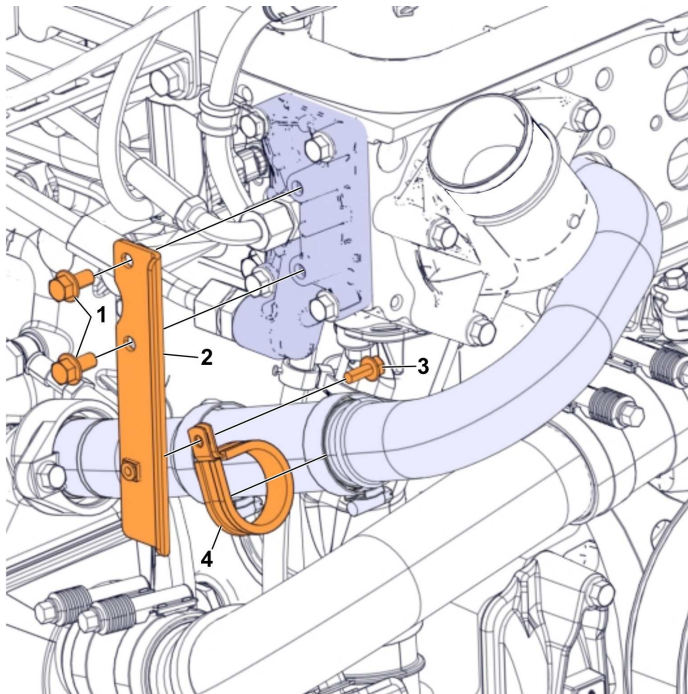

W2083410

1	Support Bracket Fastener
2	Support Bracket
3	P-clamp Fastener
4	P-clamp

- 6 Loosen the clamps securing the coolant return hose to the EGR cooler coolant return assembly. Slide the hose up onto the long section of the pipe. Remove the hose and clamps from the pipe.

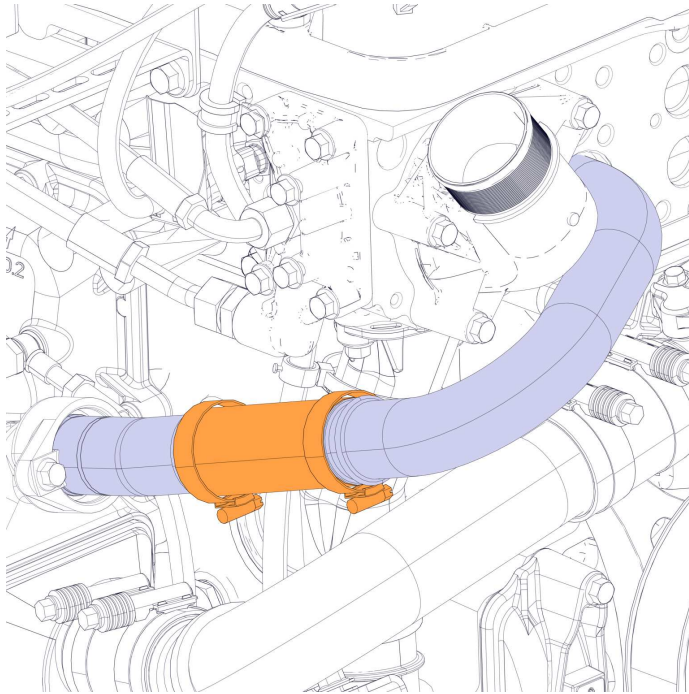

W2091580

- 7 Place the new clamps on the short pipe. Slide the new coolant return hose onto the long section of the pipe and slide it back onto the short pipe. There must be rubber on both sides of the hose clamps. Tighten the hose clamps snugly.

- 8 Position the P-clamp on the hose assembly. Loosely install the P-clamp and fastener to the support bracket before securing the bracket. Install the fasteners securing the support bracket.

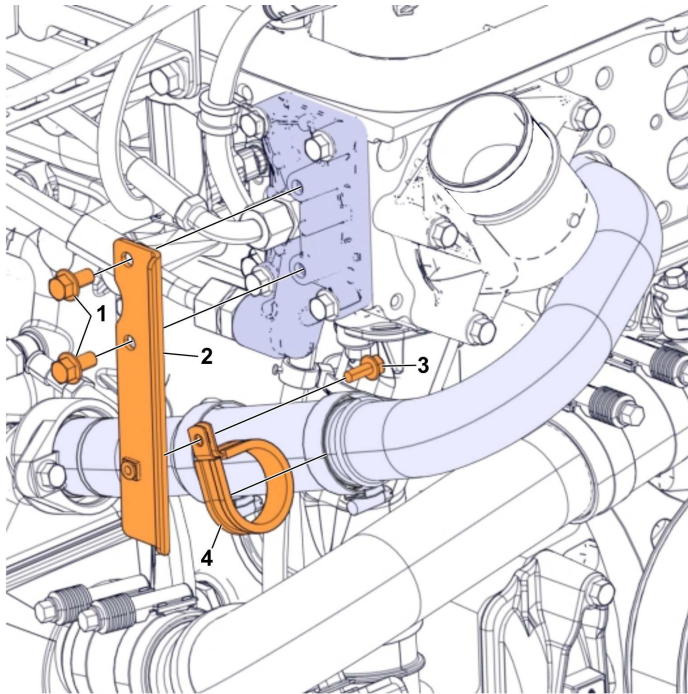

W2083410

1	Support Bracket Fastener
2	Support Bracket
3	P-clamp Fastener
4	P-clamp

- 9 Tighten the hose clamps to 5.5 ± 0.5 Nm (50 ± 4 lb-in).
- 10 Tighten the P-clamp fastener and support bracket fasteners to 24 ± 4 Nm (18 ± 3 ft-lb).
- 11 Use coolant extractor (DBT2V700) to fill the system with approved coolant.
- 12 Install all previously removed cables to the ground (negative) battery terminals.
- 13 Start the engine. Check for proper operation and leaks.
- 14 Close hood.

Reimbursement

This repair is covered by an authorized Service Program. Reimbursement is obtained via the normal claim handling process.	UCHP Reimbursement	eWarranty Reimbursement
Claim Type (used only when uploading from the Dealer Bus. Sys.)	B	B
Recall Status		
Vehicle inspected, repair not required		1- Inspected OK
Vehicle repaired per instruction		2- Modified per instruction
Labor Code		
Primary Labor Code	2934-03-09-01 0.7 hrs	29304-0-02 0.7 hrs.
Take to take charge and determine campaign status	1700-16-01-01 0.3 hrs	17003-0-01 0.3 hrs
Causal Part	22006847	22006847
Parts Disposition All parts to be scraped locally		
SCC Code	S6598	NA
Authorization Number	NA	SP293027
Expiration Date	31- Dec- 2014	31- Dec- 2014

Note: Take Charge Time is not included in the Labor Code for this operation. Take charge may be eligible but can only be used once per repair visit. If vehicle is having other warranty repairs performed, take charge should be charged to the warranty repair, otherwise take charge can be charged to this service program.