

**Bulletin Type....** : M  
**Bulletin No.....** : TS-M127  
**Bulletin Name...** : ZF Service Information Consecutive  
 No : 67/15e (Supplement to ZF-Service  
 Information Rs 11-15 and Rs 40-15)  
**Bulletin Ref.No** :  
**PQR No.....** : -  
**Rev No.....** : -  
**Release Date....** : -  
**Expiry Date.....** : -  
**Vehicle Model...** : TS 35 TS 45 Models  
**Flat Rate Code..** : TSM127  
**Flat Rate Time...** :

**Subject:** Retrofitting seal carrier,  
 readjustment/replacement of King Pin on RL 75/80/82 axles  
 must be evaluated by ZF Authorized Service.

**Summary :** All **affected vehicles must be directed to nearest Authorized ZF services in order to perform this application. For the vehicles which have already been checked in regards to this issue, this service bulletin should not be taken into account.**

In order to take the required actions according to below scenarios please get in contact with one of the local ZF services.

- a) Seal carrier without defect and movable.
- b) Seal carrier damaged / bent or distance to the king pin is < 16,5 mms.
- c) Seal carrier is missing.

**If the seal carrier is missing, no further vehicle application is allowed. In this case, immediate information to ZF or OEM to coordinate the further procedure.**

## Welding on the Chassis

- Always disconnect the batteries (starting with the negative lead).
- Disconnect the connectors of electrical and electronic equipment (electronic control units, sensors and actuators) if they are less than 2 meters away from the chassis part to be welded or the earth terminal of the welding equipment.
- The earth terminal should never be attached to vehicle components such as engine, axles and springs. Arcing on these parts is not permitted, because of the risk of damage to bearings, springs, etc.
- The earth terminal must make good contact and be placed as close as possible to the part to be welded.
- Plastic pipes, rubber parts and parabolic springs should be well protected against welding spatter and temperatures higher than 70°.

Service bulletin expiry dates differ according to service bulletin type.

## Definitions

**Release Date:** As of this date the bulletin is released and available on E-Doc. Modification parts can be ordered. The time period between the release date and the effective date may vary according to the procurement lead time.

**Effective Date:** As of this date specified amount of the total modification parts will be available on Spare Parts Stock. Modification parts can be ordered and the application can be performed. (except non-compliance and safety related campaigns, i.e. S-Type Bulletin)

**Part Order Deadline:** Last order date for modification parts. The part orders which will be placed after this date should be approved by Regional Coordinator.

**Expiry Date:** Expiration date for the application.

## Bulletin Types

- **S-Type:** Application period of this bulletin is 18 months after the date of issue. S type bulletin is used for Recall Campaigns.



- **U-Type :** Application period of this bulletin is 12 months after the date of issue. U type bulletin is used for updates that need to be performed upon customer complaints.

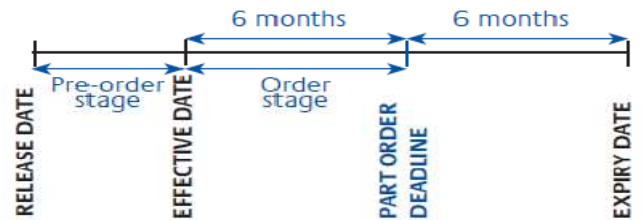

- **C-Type:** Application period of this bulletin is 12 months after the date of issue. C type bulletin is generally used for supplying technical instructions or other type of information to service network.

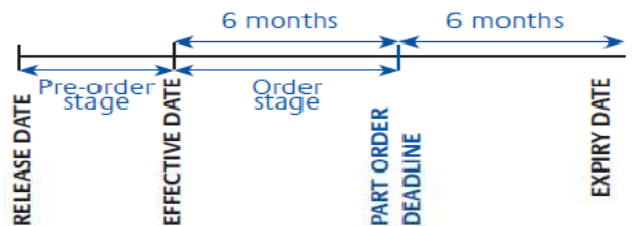

- **M-Type:** Application period of this bulletin is 12 months after the date of issue. M type bulletin is used for updates that should be implemented without waiting for customer complaints.

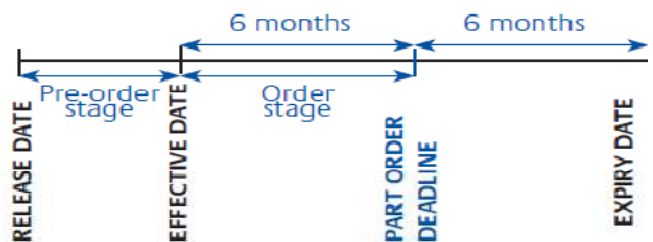

## GENERAL PRECAUTIONS

### 1. Suggested Dress Code:

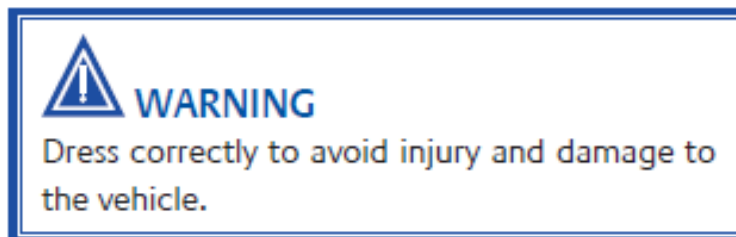

### 2. Before Starting the Work:

Always wear protective clothing. Do not wear any damaged or loose-fitting clothing and remove jewelry before starting the work. In case of long hair use hairnet. The illustration above shows some of the correct and incorrect clothing that should be worn during work. Sharp edges should be avoided e.g belts, watches, necklaces etc.

### 3. Interior materials protection:

Seats, trimming, upholstery stuff and carpeting should be protected with appropriate coverings.

## Application:

File: 1  
 Type: Assembly Instructions  
 Consecutive no.: 67/15e  
 Date: 12.02.2016

## Service Information



### RL 75/80/82 Procedure retrofitting seal carrier, readjustment/replacement kingpin (Supplement to ZF-Service Information Rs 11-15 and Rs 40-15)

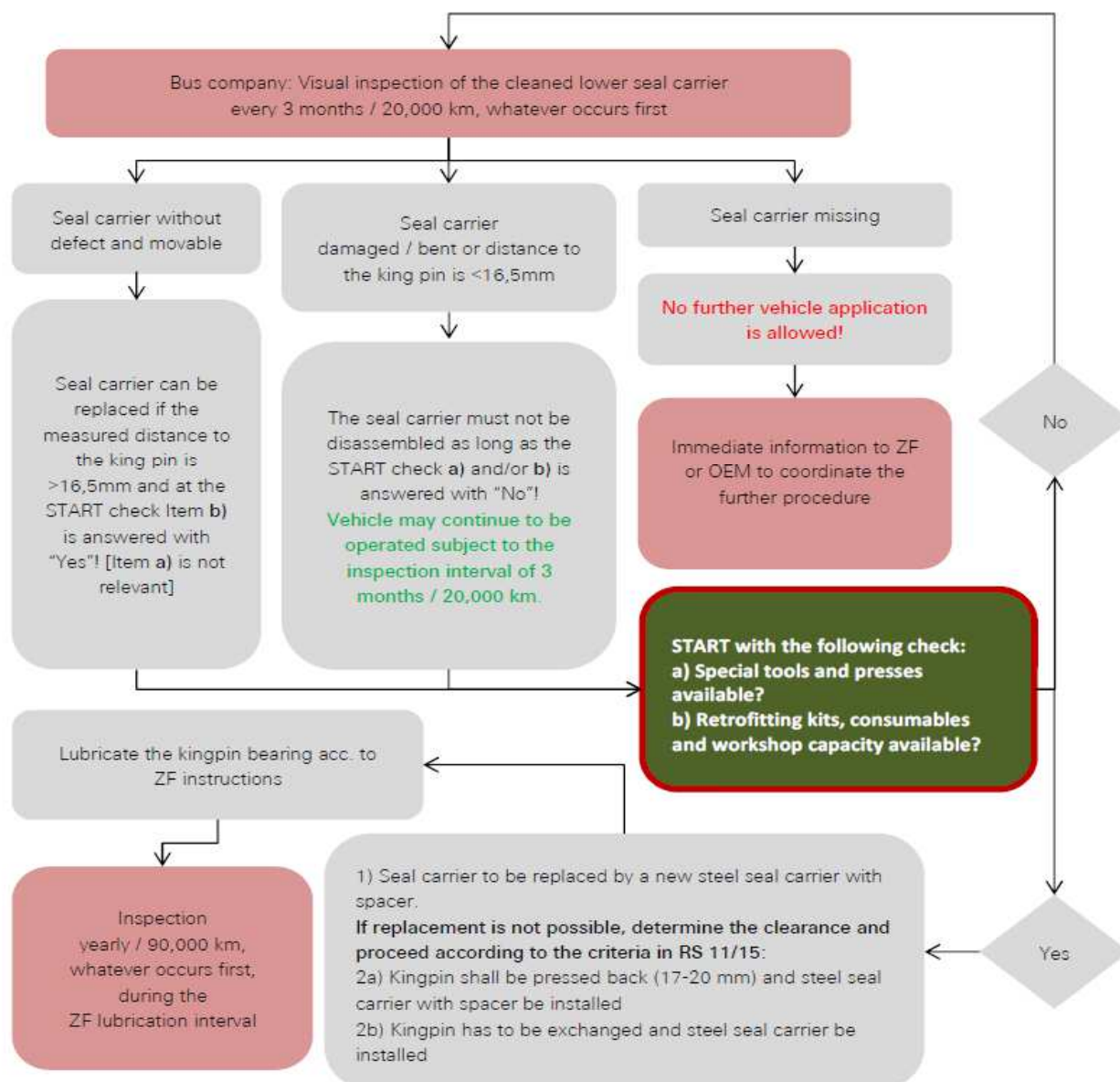

19079101.08

Vorsitzender des Aufsichtsrats: Prof. Dr. Giorgio Behr  
 Vorstand: Dr. Stefan Sommer (Vorsitzender/CEO), Dr. Konstantin Seuer,  
 Jürgen Holeksa, Michael Hankel, Wilhelm Rehm, Rolf Lutz, Dr. Franz Kleiner  
 Sitz: Friedrichshafen • Handelsregistereintrag: Amtsgericht Ulm HRB 630206  
 www.zf.com • postoffice@zf.com

ZF Friedrichshafen AG  
 ZF Services  
 Donaustr. 71  
 D- 94034 Passau  
 Deutschland  
 Telefon: +49 851 494-0  
 Telefax: +49 851 494 90 5000



These instructions are only applicable to RL 75/82 with ZF wheel head, visible due to ZF-Logo on hub cover.  
Other  
ZF axles without ZF wheel head are not affected!

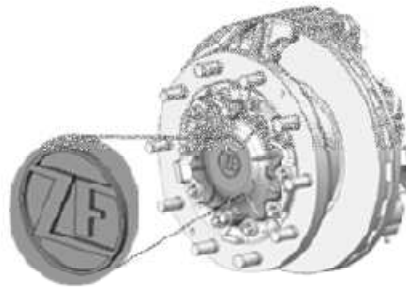

The originally installed die cast seal carrier (see rod marking) must be replaced by a steel seal carrier.

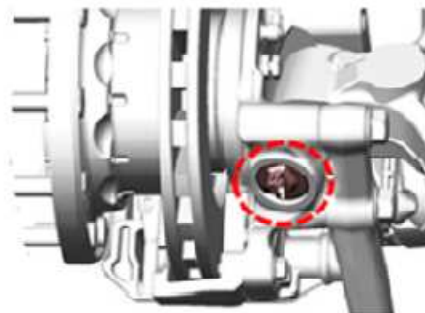

Change of die cast seal carrier  
to steel seal carrier





**2. Visual and manual inspection of both axle sides (every 3 months / 20.000 km, as long as the steel sealing holder is not installed; annually / maximum 90.000 km after installation of steel sealing holder)**

- Checking by hand whether sealing holder and grease fitting is still in position
- Cleaning of lower seal holder and retaining ring
- Checking of lower seal holder for damages
- Inspect seat and position of retaining ring

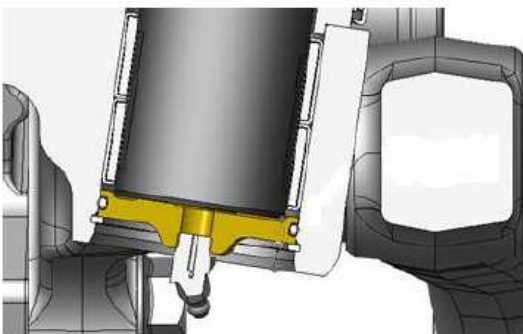

Inspection of seal holder and retaining ring

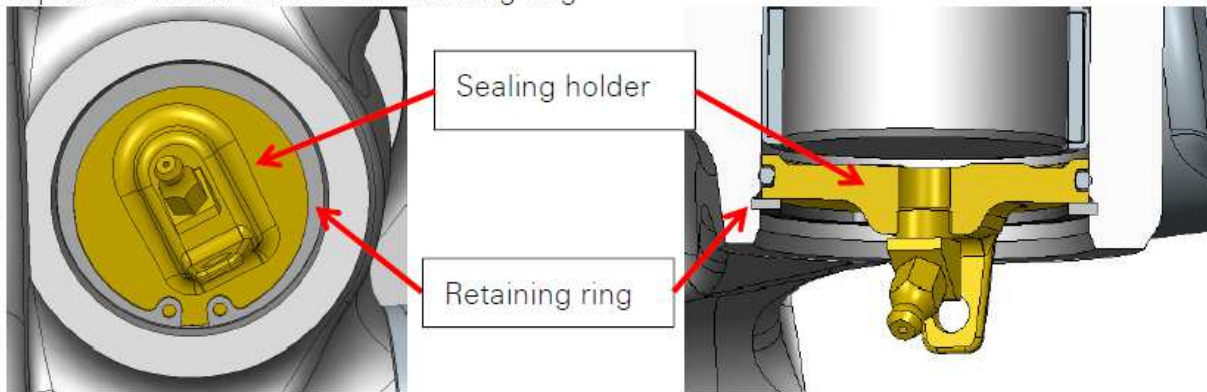

# SERVICE BULLETIN

## AFFECTED VEHICLE LIST

NO	VIN	COUNTRY
1	NLTEJXU80F1000009	USA
2	NLTEJXU80F1000012	USA
3	NLTEJXU80F1000026	USA
4	NLTEJXU80F1000043	USA
5	NLTEJXU80F1000057	USA
6	NLTEJXU81F1000018	USA
7	NLTEJXU81F1000021	USA
8	NLTEJXU81F1000035	USA
9	NLTEJXU81F1000049	USA
10	NLTEJXU81F1000052	USA
11	NLTEJXU82F1000013	USA
12	NLTEJXU82F1000027	USA
13	NLTEJXU82F1000030	USA
14	NLTEJXU82F1000044	USA
15	NLTEJXU82F1000058	USA
16	NLTEJXU83E1000004	USA
17	NLTEJXU83F1000019	USA
18	NLTEJXU83F1000022	USA
19	NLTEJXU83F1000036	USA
20	NLTEJXU83F1000053	USA
21	NLTEJXU84F1000014	USA
22	NLTEJXU84F1000028	USA
23	NLTEJXU84F1000031	USA
24	NLTEJXU84F1000045	USA
25	NLTEJXU84F1000059	USA
26	NLTEJXU85E1000005	USA
27	NLTEJXU85F1000006	USA
28	NLTEJXU85F1000023	USA
29	NLTEJXU85F1000037	USA
30	NLTEJXU85F1000040	USA
31	NLTEJXU85F1000054	USA
32	NLTEJXU86F1000015	USA
33	NLTEJXU86F1000029	USA
34	NLTEJXU86F1000032	USA
35	NLTEJXU86F1000046	USA
36	NLTEJXU87F1000007	USA
37	NLTEJXU87F1000010	USA
38	NLTEJXU87F1000024	USA
39	NLTEJXU87F1000038	USA

# SERVICE BULLETIN

40	NLTEJXU87F1000041	USA
41	NLTEJXU87F1000055	USA
42	NLTEJXU88F1000016	USA
43	NLTEJXU88F1000033	USA
44	NLTEJXU88F1000047	USA
45	NLTEJXU88F1000050	USA
46	NLTEJXU89F1000008	USA
47	NLTEJXU89F1000011	USA
48	NLTEJXU89F1000025	USA
49	NLTEJXU89F1000039	USA
50	NLTEJXU89F1000042	USA
51	NLTEJXU89F1000056	USA
52	NLTEJXU8XF1000017	USA
53	NLTEJXU8XF1000020	USA
54	NLTEJXU8XF1000034	USA
55	NLTEJXU8XF1000048	USA
56	NLTEJXU8XF1000051	USA
57	NLTEJXX84G1000060	USA
58	NLTEJXX86G1000061	USA
59	NLTEJXX88G1000062	USA
60	NLTNVS7L01000259	USA
61	NLTRPPN7081000004	USA
62	NLTRPPN7091000005	USA
63	NLTRPPN7091000019	USA
64	NLTRPPN70A1000025	USA
65	NLTRPPN70A1000039	USA
66	NLTRPPN70A1000042	USA
67	NLTRPPN70A1000056	USA
68	NLTRPPN7191000014	USA
69	NLTRPPN71A1000020	USA
70	NLTRPPN71A1000034	USA
71	NLTRPPN71A1000048	USA
72	NLTRPPN71A1000051	USA
73	NLTRPPN71A1000065	USA
74	NLTRPPN7291000006	USA
75	NLTRPPN72A1000043	USA
76	NLTRPPN72A1000057	USA
77	NLTRPPN72A1000060	USA
78	NLTRPPN7391000032	USA
79	NLTRPPN73A1000021	USA
80	NLTRPPN73A1000049	USA
81	NLTRPPN73A1000052	USA
82	NLTRPPN73A1000066	USA



# SERVICE BULLETIN

83	NLTRPPN7491000010	USA
84	NLTRPPN7491000038	USA
85	NLTRPPN74A1000027	USA
86	NLTRPPN74A1000044	USA
87	NLTRPPN74A1000058	USA
88	NLTRPPN74A1000061	USA
89	NLTRPPN7591000016	USA
90	NLTRPPN75A1000022	USA
91	NLTRPPN75A1000036	USA
92	NLTRPPN75A1000053	USA
93	NLTRPPN75A1000067	USA
94	NLTRPPN75A1000070	USA
95	NLTRPPN7691000008	USA
96	NLTRPPN7691000011	USA
97	NLTRPPN76A1000028	USA
98	NLTRPPN76A1000031	USA
99	NLTRPPN76A1000045	USA
100	NLTRPPN76A1000059	USA
101	NLTRPPN76A1000062	USA
102	NLTRPPN7791000017	USA
103	NLTRPPN77A1000023	USA
104	NLTRPPN77A1000037	USA
105	NLTRPPN77A1000040	USA
106	NLTRPPN77A1000054	USA
107	NLTRPPN77A1000068	USA
108	NLTRPPN77A1000071	USA
109	NLTRPPN7891000009	USA
110	NLTRPPN7891000012	USA
111	NLTRPPN7891000026	USA
112	NLTRPPN78A1000015	USA
113	NLTRPPN78A1000029	USA
114	NLTRPPN78A1000046	USA
115	NLTRPPN78A1000063	USA
116	NLTRPPN7991000018	USA
117	NLTRPPN7991000035	USA
118	NLTRPPN79A1000024	USA
119	NLTRPPN79A1000041	USA
120	NLTRPPN79A1000055	USA
121	NLTRPPN79A1000069	USA
122	NLTRPPN79A1000072	USA
123	NLTRPPN7X91000013	USA
124	NLTRPPN7X91000030	USA
125	NLTRPPN7XA1000033	USA

# SERVICE BULLETIN

126	NLTRPPN7XA1000047	USA
127	NLTRPPN7XA1000050	USA
128	NLTRPPN7XA1000064	USA
129	NLTRPPP70A1000006	USA
130	NLTRPPP71A1000001	USA
131	NLTRPPP72A1000007	USA
132	NLTRPPP72A1000010	USA
133	NLTRPPP73A1000002	USA
134	NLTRPPP74A1000008	USA
135	NLTRPPP74A1000011	USA
136	NLTRPPP75A1000003	USA
137	NLTRPPP76A1000009	USA
138	NLTRPPP77A1000004	USA
139	NLTRPPP79A1000005	USA
140	NLTRPPR70B1000005	USA
141	NLTRPPR70C1000006	USA
142	NLTRPPR70C1000023	USA
143	NLTRPPR70C1000037	USA
144	NLTRPPR70C1000040	USA
145	NLTRPPR70C1000054	USA
146	NLTRPPR70C1000068	USA
147	NLTRPPR70C1000071	USA
148	NLTRPPR70D1000086	USA
149	NLTRPPR70D1000105	USA
150	NLTRPPR70D1000119	USA
151	NLTRPPR70D1000122	USA
152	NLTRPPR70D1000136	USA
153	NLTRPPR70D1000153	USA
154	NLTRPPR70D1000167	USA
155	NLTRPPR70D1000170	USA
156	NLTRPPR71C1000001	USA
157	NLTRPPR71C1000015	USA
158	NLTRPPR71C1000029	USA
159	NLTRPPR71C1000032	USA
160	NLTRPPR71C1000046	USA
161	NLTRPPR71C1000063	USA
162	NLTRPPR71C1000077	USA
163	NLTRPPR71C1000080	USA
164	NLTRPPR71C1000094	USA
165	NLTRPPR71D1000100	USA
166	NLTRPPR71D1000114	USA
167	NLTRPPR71D1000128	USA
168	NLTRPPR71D1000131	USA

# SERVICE BULLETIN

169	NLTRPPR71D1000145	USA
170	NLTRPPR71D1000159	USA
171	NLTRPPR71D1000162	USA
172	NLTRPPR72B1000006	USA
173	NLTRPPR72C1000007	USA
174	NLTRPPR72C1000010	USA
175	NLTRPPR72C1000024	USA
176	NLTRPPR72C1000038	USA
177	NLTRPPR72C1000041	USA
178	NLTRPPR72C1000055	USA
179	NLTRPPR72C1000069	USA
180	NLTRPPR72C1000072	USA
181	NLTRPPR72D1000087	USA
182	NLTRPPR72D1000090	USA
183	NLTRPPR72D1000106	USA
184	NLTRPPR72D1000123	USA
185	NLTRPPR72D1000137	USA
186	NLTRPPR72D1000140	USA
187	NLTRPPR72D1000154	USA
188	NLTRPPR72D1000168	USA
189	NLTRPPR72D1000171	USA
190	NLTRPPR73C1000002	USA
191	NLTRPPR73C1000016	USA
192	NLTRPPR73C1000033	USA
193	NLTRPPR73C1000047	USA
194	NLTRPPR73C1000050	USA
195	NLTRPPR73C1000064	USA
196	NLTRPPR73C1000078	USA
197	NLTRPPR73C1000081	USA
198	NLTRPPR73C1000095	USA
199	NLTRPPR73D1000082	USA
200	NLTRPPR73D1000101	USA
201	NLTRPPR73D1000115	USA
202	NLTRPPR73D1000129	USA
203	NLTRPPR73D1000132	USA
204	NLTRPPR73D1000146	USA
205	NLTRPPR73D1000163	USA
206	NLTRPPR74B1000007	USA
207	NLTRPPR74B1000010	USA
208	NLTRPPR74C1000008	USA
209	NLTRPPR74C1000011	USA
210	NLTRPPR74C1000025	USA
211	NLTRPPR74C1000039	USA

# SERVICE BULLETIN

212	NLTRPPR74C1000042	USA
213	NLTRPPR74C1000056	USA
214	NLTRPPR74C1000073	USA
215	NLTRPPR74D1000088	USA
216	NLTRPPR74D1000107	USA
217	NLTRPPR74D1000110	USA
218	NLTRPPR74D1000124	USA
219	NLTRPPR74D1000138	USA
220	NLTRPPR74D1000141	USA
221	NLTRPPR74D1000155	USA
222	NLTRPPR74D1000169	USA
223	NLTRPPR74D1000172	USA
224	NLTRPPR75B1000002	USA
225	NLTRPPR75C1000003	USA
226	NLTRPPR75C1000017	USA
227	NLTRPPR75C1000020	USA
228	NLTRPPR75C1000034	USA
229	NLTRPPR75C1000048	USA
230	NLTRPPR75C1000051	USA
231	NLTRPPR75C1000065	USA
232	NLTRPPR75C1000079	USA
233	NLTRPPR75C1000096	USA
234	NLTRPPR75D1000083	USA
235	NLTRPPR75D1000097	USA
236	NLTRPPR75D1000102	USA
237	NLTRPPR75D1000133	USA
238	NLTRPPR75D1000147	USA
239	NLTRPPR75D1000150	USA
240	NLTRPPR75D1000164	USA
241	NLTRPPR76B1000008	USA
242	NLTRPPR76B1000011	USA
243	NLTRPPR76C1000009	USA
244	NLTRPPR76C1000012	USA
245	NLTRPPR76C1000026	USA
246	NLTRPPR76C1000043	USA
247	NLTRPPR76C1000057	USA
248	NLTRPPR76C1000060	USA
249	NLTRPPR76C1000074	USA
250	NLTRPPR76C1000091	USA
251	NLTRPPR76D1000089	USA
252	NLTRPPR76D1000108	USA
253	NLTRPPR76D1000111	USA
254	NLTRPPR76D1000125	USA

# SERVICE BULLETIN

255	NLTRPPR76D1000139	USA
256	NLTRPPR76D1000142	USA
257	NLTRPPR76D1000156	USA
258	NLTRPPR76D1000173	USA
259	NLTRPPR77B1000003	USA
260	NLTRPPR77C1000004	USA
261	NLTRPPR77C1000018	USA
262	NLTRPPR77C1000021	USA
263	NLTRPPR77C1000035	USA
264	NLTRPPR77C1000049	USA
265	NLTRPPR77C1000052	USA
266	NLTRPPR77C1000066	USA
267	NLTRPPR77D1000084	USA
268	NLTRPPR77D1000098	USA
269	NLTRPPR77D1000103	USA
270	NLTRPPR77D1000117	USA
271	NLTRPPR77D1000120	USA
272	NLTRPPR77D1000134	USA
273	NLTRPPR77D1000148	USA
274	NLTRPPR77D1000151	USA
275	NLTRPPR77D1000165	USA
276	NLTRPPR78B1000009	USA
277	NLTRPPR78C1000013	USA
278	NLTRPPR78C1000027	USA
279	NLTRPPR78C1000030	USA
280	NLTRPPR78C1000044	USA
281	NLTRPPR78C1000058	USA
282	NLTRPPR78C1000061	USA
283	NLTRPPR78C1000075	USA
284	NLTRPPR78C1000092	USA
285	NLTRPPR78D1000109	USA
286	NLTRPPR78D1000112	USA
287	NLTRPPR78D1000143	USA
288	NLTRPPR78D1000157	USA
289	NLTRPPR78D1000160	USA
290	NLTRPPR79B1000004	USA
291	NLTRPPR79C1000005	USA
292	NLTRPPR79C1000019	USA
293	NLTRPPR79C1000022	USA
294	NLTRPPR79C1000036	USA
295	NLTRPPR79C1000053	USA
296	NLTRPPR79C1000067	USA
297	NLTRPPR79C1000070	USA

# SERVICE BULLETIN

298	NLTRPPR79D1000085	USA
299	NLTRPPR79D1000099	USA
300	NLTRPPR79D1000104	USA
301	NLTRPPR79D1000118	USA
302	NLTRPPR79D1000121	USA
303	NLTRPPR79D1000135	USA
304	NLTRPPR79D1000149	USA
305	NLTRPPR79D1000152	USA
306	NLTRPPR79D1000166	USA
307	NLTRPPR7XC1000014	USA
308	NLTRPPR7XC1000028	USA
309	NLTRPPR7XC1000031	USA
310	NLTRPPR7XC1000045	USA
311	NLTRPPR7XC1000059	USA
312	NLTRPPR7XC1000062	USA
313	NLTRPPR7XC1000076	USA
314	NLTRPPR7XC1000093	USA
315	NLTRPPR7XD1000113	USA
316	NLTRPPR7XD1000127	USA
317	NLTRPPR7XD1000144	USA
318	NLTRPPR7XD1000158	USA
319	NLTRPPR7XD1000161	USA
320	NLTRPPU70E1000016	USA
321	NLTRPPU70E1000209	USA
322	NLTRPPU70E1000212	USA
323	NLTRPPU70E1000226	USA
324	NLTRPPU70E1000243	USA
325	NLTRPPU70E1000257	USA
326	NLTRPPU70E1000260	USA
327	NLTRPPU70E1000274	USA
328	NLTRPPU70F1000289	USA
329	NLTRPPU70F1000292	USA
330	NLTRPPU70F1000308	USA
331	NLTRPPU70F1000311	USA
332	NLTRPPU70F1000325	USA
333	NLTRPPU71E1000008	USA
334	NLTRPPU71E1000011	USA
335	NLTRPPU71E1000025	USA
336	NLTRPPU71E1000204	USA
337	NLTRPPU71E1000218	USA
338	NLTRPPU71E1000221	USA
339	NLTRPPU71E1000235	USA
340	NLTRPPU71E1000249	USA

# SERVICE BULLETIN

341	NLTRPPU71E1000252	USA
342	NLTRPPU71E1000266	USA
343	NLTRPPU71F1000284	USA
344	NLTRPPU71F1000298	USA
345	NLTRPPU71F1000303	USA
346	NLTRPPU71F1000317	USA
347	NLTRPPU71F1000320	USA
348	NLTRPPU72D1000002	USA
349	NLTRPPU72E1000017	USA
350	NLTRPPU72E1000020	USA
351	NLTRPPU72E1000213	USA
352	NLTRPPU72E1000227	USA
353	NLTRPPU72E1000230	USA
354	NLTRPPU72E1000244	USA
355	NLTRPPU72E1000258	USA
356	NLTRPPU72E1000261	USA
357	NLTRPPU72E1000275	USA
358	NLTRPPU72F1000293	USA
359	NLTRPPU72F1000309	USA
360	NLTRPPU72F1000312	USA
361	NLTRPPU72F1000326	USA
362	NLTRPPU73E1000009	USA
363	NLTRPPU73E1000012	USA
364	NLTRPPU73E1000026	USA
365	NLTRPPU73E1000205	USA
366	NLTRPPU73E1000219	USA
367	NLTRPPU73E1000222	USA
368	NLTRPPU73E1000236	USA
369	NLTRPPU73E1000253	USA
370	NLTRPPU73E1000267	USA
371	NLTRPPU73E1000270	USA
372	NLTRPPU73F1000285	USA
373	NLTRPPU73F1000299	USA
374	NLTRPPU73F1000304	USA
375	NLTRPPU73F1000318	USA
376	NLTRPPU73F1000321	USA
377	NLTRPPU74D1000003	USA
378	NLTRPPU74E1000018	USA
379	NLTRPPU74E1000021	USA
380	NLTRPPU74E1000200	USA
381	NLTRPPU74E1000214	USA
382	NLTRPPU74E1000228	USA
383	NLTRPPU74E1000231	USA

# SERVICE BULLETIN

384	NLTRPPU74E1000245	USA
385	NLTRPPU74E1000259	USA
386	NLTRPPU74E1000262	USA
387	NLTRPPU74E1000276	USA
388	NLTRPPU74F1000280	USA
389	NLTRPPU74F1000294	USA
390	NLTRPPU74F1000313	USA
391	NLTRPPU74F1000327	USA
392	NLTRPPU74F1000330	USA
393	NLTRPPU75E1000013	USA
394	NLTRPPU75E1000206	USA
395	NLTRPPU75E1000223	USA
396	NLTRPPU75E1000237	USA
397	NLTRPPU75E1000240	USA
398	NLTRPPU75E1000254	USA
399	NLTRPPU75E1000268	USA
400	NLTRPPU75E1000271	USA
401	NLTRPPU75F1000286	USA
402	NLTRPPU75F1000305	USA
403	NLTRPPU75F1000319	USA
404	NLTRPPU75F1000322	USA
405	NLTRPPU76D1000004	USA
406	NLTRPPU76E1000019	USA
407	NLTRPPU76E1000022	USA
408	NLTRPPU76E1000201	USA
409	NLTRPPU76E1000215	USA
410	NLTRPPU76E1000229	USA
411	NLTRPPU76E1000232	USA
412	NLTRPPU76E1000246	USA
413	NLTRPPU76E1000263	USA
414	NLTRPPU76E1000277	USA
415	NLTRPPU76F1000281	USA
416	NLTRPPU76F1000295	USA
417	NLTRPPU76F1000300	USA
418	NLTRPPU76F1000314	USA
419	NLTRPPU76F1000328	USA
420	NLTRPPU77E1000014	USA
421	NLTRPPU77E1000207	USA
422	NLTRPPU77E1000210	USA
423	NLTRPPU77E1000224	USA
424	NLTRPPU77E1000238	USA
425	NLTRPPU77E1000241	USA
426	NLTRPPU77E1000255	USA



# SERVICE BULLETIN

427	NLTRPPU77E1000269	USA
428	NLTRPPU77E1000272	USA
429	NLTRPPU77F1000287	USA
430	NLTRPPU77F1000290	USA
431	NLTRPPU77F1000306	USA
432	NLTRPPU77F1000323	USA
433	NLTRPPU78D1000005	USA
434	NLTRPPU78E1000023	USA
435	NLTRPPU78E1000202	USA
436	NLTRPPU78E1000216	USA
437	NLTRPPU78E1000233	USA
438	NLTRPPU78E1000247	USA
439	NLTRPPU78E1000250	USA
440	NLTRPPU78E1000264	USA
441	NLTRPPU78E1000278	USA
442	NLTRPPU78F1000282	USA
443	NLTRPPU78F1000296	USA
444	NLTRPPU78F1000301	USA
445	NLTRPPU78F1000315	USA
446	NLTRPPU78F1000329	USA
447	NLTRPPU79E1000001	USA
448	NLTRPPU79E1000015	USA
449	NLTRPPU79E1000208	USA
450	NLTRPPU79E1000211	USA
451	NLTRPPU79E1000225	USA
452	NLTRPPU79E1000239	USA
453	NLTRPPU79E1000242	USA
454	NLTRPPU79E1000256	USA
455	NLTRPPU79E1000273	USA
456	NLTRPPU79F1000288	USA
457	NLTRPPU79F1000291	USA
458	NLTRPPU79F1000307	USA
459	NLTRPPU79F1000310	USA
460	NLTRPPU79F1000324	USA
461	NLTRPPU7XD1000006	USA
462	NLTRPPU7XE1000007	USA
463	NLTRPPU7XE1000010	USA
464	NLTRPPU7XE1000024	USA
465	NLTRPPU7XE1000203	USA
466	NLTRPPU7XE1000217	USA
467	NLTRPPU7XE1000220	USA
468	NLTRPPU7XE1000234	USA
469	NLTRPPU7XE1000248	USA

# SERVICE BULLETIN

470	NLTRPPU7XE1000251	USA
471	NLTRPPU7XE1000265	USA
472	NLTRPPU7XE1000279	USA
473	NLTRPPU7XF1000283	USA
474	NLTRPPU7XF1000297	USA
475	NLTRPPU7XF1000302	USA
476	NLTRPPU7XF1000316	USA
477	NLTRPPX71G1000332	USA
478	NLTRPPX7XG1000331	USA