



DETROITTM
DEMAND PERFORMANCESM

**18SP701Rev2– GHG14 Two-Filter Fuel System
KM63 GEN2 DD15AT Engines High Pressure
Fuel Feed Lines, Mounting Bracket and P-clips
Service Kit (P/N: A4730704432)**



⚠ WARNING:

PERSONAL INJURY

All parts provided within this kit must be installed in the proper locations, and **MUST** be fastened to the specified torque. Failure to properly torque hardware/components will result in failure of a high pressure fuel feed line, resulting in possible fire and/or personal injury.

⚠ WARNING:

PERSONAL INJURY

All parts provided with this kit are single-use items and cannot be reused. Reuse of hardware/component items may result in the failure of a high pressure fuel line, resulting in possible fire and/or personal injury.

NOTICE:

Failure to follow these instructions will result in catastrophic damage to the engine and will not be covered under warranty.

KIT DESCRIPTION

This service kit includes all necessary parts to replace the high pressure fuel feed lines, mounting bracket and P-clips in the event one of these parts are loosened, removed or missing from the engine.

KIT CONTENTS

Service kit P/N: A4730704432 contains all of the necessary parts to replace the high pressure fuel feed lines on GHG14 DD15AT engines.

Part No.	Qty.	Description
A4730780210	2	High pressure fuel feed line
A4720700540	2	P-Clip
N000000007957	2	Bolt M6x12mm
N910105006023	2	Bolt M6x16mm
A4720701140	1	Mounting bracket
18SP701Rev2	1	Installation Instructions

Removal of the High Pressure Fuel Rail Feed Lines

Remove as follows:

WARNING:

PERSONAL INJURY

To prevent the escape of high pressure fuel that can penetrate skin, ensure the engine has been shut down for a minimum of 10 minutes before servicing any component within the high pressure circuit. Residual high pressure fuel may be present within the circuit.

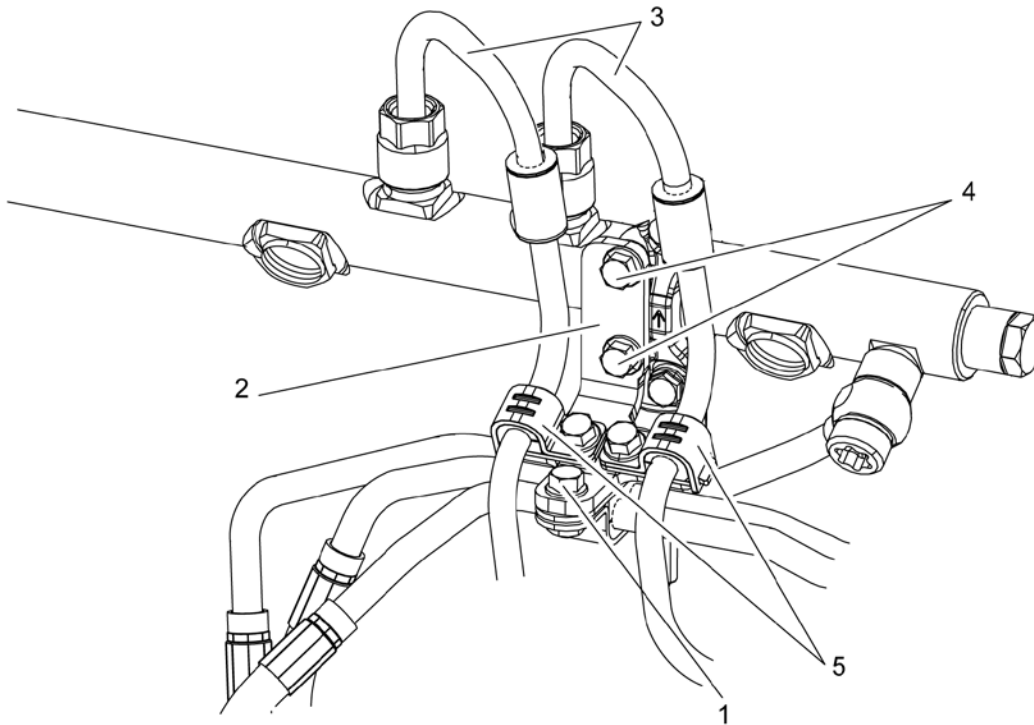

d470251

Item	Component
1	Reused Return lines P-clip bolt
2	Mounting bracket
3	High pressure fuel feed lines
4	Mounting bracket bolts
5	P-clips and bolts

1. Disconnect the batteries.

NOTE: Do not discard the return lines P-clip and bolt. They will be reused on the installation of the high pressure fuel rail feed lines.

2. Remove the return lines P-clip bolt (1) from the mounting bracket (2).
3. Remove and discard the two bolts and P-clips (5) from the mounting bracket (2).
4. Remove and discard the mounting bracket bolts (4) from the fuel rail clamp and discard the mounting bracket (2).
5. Using tool J-48770, remove and discard the high pressure fuel rail feed lines (3) from the fuel rail and high pressure fuel pump.

Installation of the High Pressure Fuel Rail Feed Lines

Install as follows:

NOTE:

DO NOT install bolts and fittings using power tools. All bolts and fittings MUST be installed using hand tools.

WARNING:

PERSONAL INJURY

All hardware components must be installed in the proper locations, and MUST be fastened to the specified torque. Failure to properly torque hardware/components will result in failure of a high pressure fuel feed line, resulting in possible fire and/or personal injury.

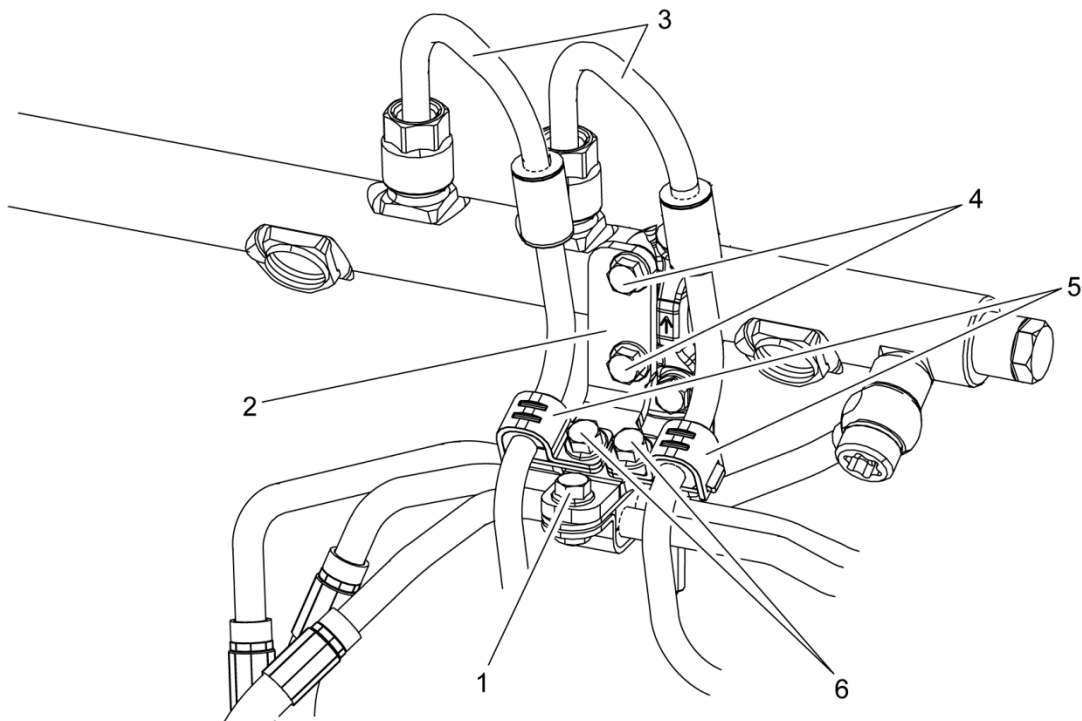

d470317

Item	Component	Part number
1	Return lines P-clip bolt	Reused
2	Mounting bracket	A4720701140
3	High pressure fuel feed lines	A4730780210
4	Mounting bracket bolts	N910105006023
5	P-clips	A4720700240
6	P-clip bolts	N000000007957

1. Clean the sealing area inside the high pressure fuel pump fittings using a clean lint-free cloth.



2. Clean the sealing area inside the high pressure fuel rail using a clean lint-free cloth.



3. Install the new mounting bracket (2) (P/N: A4720701140) and two new mounting bracket bolts (4) (P/N: N910105006023) to the fuel rail clamp. Torque to 15 N·m (132 lb·in.).

NOTICE:

New P-clip MUST be installed on to the high pressure fuel rail feed lines with the Lower P-clip Plate (A) inserted in to the P-clip Window (B).

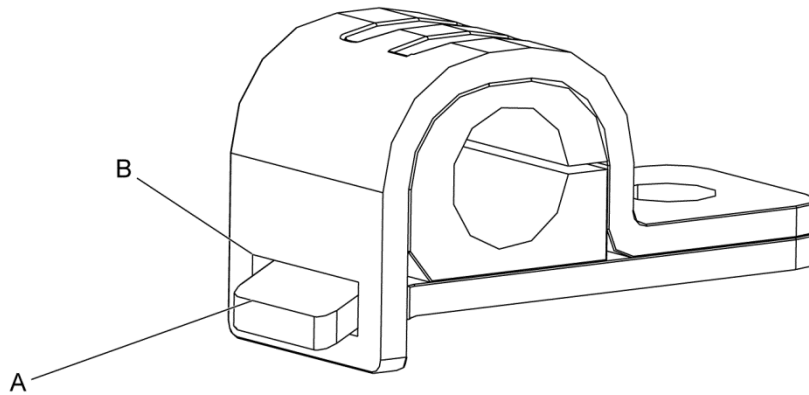

d470247a

4. Install both P-clips (5) (P/N: A4720700240) onto both the high pressure fuel rail feed lines (3) (P/N: A4730780210).

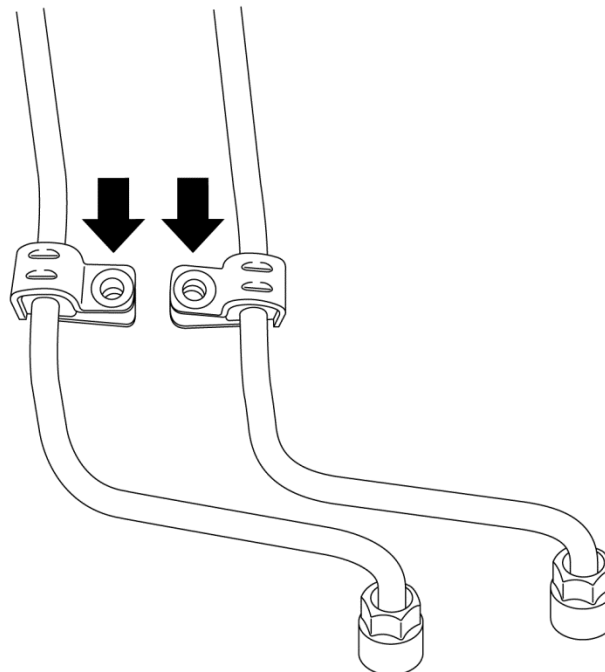

d470315

5. Install the rear high pressure fuel rail feed line (3) to the fuel rail and the high pressure fuel pump. Hand tighten the nuts.
6. Using tool J-48770, torque the rear high pressure fuel rail feed line (3) nuts to 40 N·m (30 lb·ft).
7. Using a new P-clip bolt (6) (N000000007957), install the P-clip (5) on to the mounting bracket (2). Hand tighten the bolt.
8. Install the front high pressure fuel rail feed line (3) on to the fuel rail and the high pressure fuel pump. Hand tighten the nuts.
9. Using tool J-48770, torque the front high pressure fuel rail feed line (3) nuts to 40 N·m (30 lb·ft).
10. Using a new P-clip bolt (6) (N000000007957), install the P-clip (5) on to the mounting bracket (2). Hand tighten the bolt.
11. Reinstall the return lines P-clip bolt (1). Torque to 15 N·m (132 lb·in.).
12. Torque both new P-clips bolts (6) to 15 N·m (132 lb·in.).

NOTICE:

DO NOT use the high pressure fuel rail feed lines without new P-clips, vibration dampers and bolts installed.



CAUTION:

ELECTRICAL SHOCK

To avoid injury from electrical shock, use care when connecting battery cables. The magnetic switch studs are at battery voltage.

13. Connect the batteries.
14. Prime the fuel system. [Refer to section "Priming of the Fuel System Using ESOC 350 Fuel Priming Pump."](#)
15. Perform the Rail Pressure Bleed-Off test to verify that there are no leaks. [Refer to section "Rail Pressure Bleed-Off Test Using DDDL Two Filter System "](#)
[Refer to section "Fuel Injection System \(FIS\) Leak Detection \(EPA10\)."](#)
16. If there are leaks, find the leak and repair, as necessary.



13400 Outer Drive, West, Detroit, Michigan 48239-4001
Telephone: 313-592-5000
WWW.DEMANDETROIT.COM

Specifications are subject to change without notice. Detroit Diesel Corporation is registered to ISO 9001:2008. Copyright © Detroit Diesel Corporation. All rights reserved. Detroit™ is a brand of Detroit Diesel Corporation, a Daimler company.

18SP701Rev2 1406 As technical advances continue, specifications will change. Printed in U.S.A.