

**Refuse Deflector Installation for
McNeilus or Agility 60 DGE CNG Roof
Mounted Systems**

Date: January 2, 2018
Bulletin Name: FEL-TSIB-052-A
Model: Contender FEL 87
Model Year: 2011 - 2017
Units Affected: McNeilus or Agility CNG
 Roof Mounted Systems

Purpose:

The following instructions are for installing a refuse deflector system on a 60 DGE McNeilus or Agility roof mounted Compressed Natural Gas (CNG) system to help prevent debris build-up between the back of the hopper deflector and the CNG cabinets.

Notice:

- This bulletin should be read and understood in its entirety before performing this procedure.
- All procedures outlined in the bulletin must be performed by skilled service personnel. Refer to the product service manual for descriptions of maintenance procedures.

SAFETY NOTICE

Perform your company's Lockout/Tagout procedure. If your company does not have a Lockout/Tagout procedure, follow OSHA 1910.147 and 1910.146 Confined Space as appropriate.

SAFETY NOTICE

Use appropriate Personal Protective Equipment (PPE) as required by your company.

Equipment Required:

Customer to supply:

- Ladder
- Torque wrench
- Overhead crane or other lifting system with slings rated for 200 lbs.

Parts Required:

Item	P/N	Description	Qty.
1	1572662	WELDMENT, 60 DGE REFUSE DEFLECTOR COVER	1
2	1572664	WELDMENT, STREET SIDE, COVER 60 DGE WINDGUARD RECTANGLE	1
3	1572666	WELDMENT, CURB SIDE, COVER 60 DGE WINDGUARD RECTANGLE	1
4	1572667	COVER, 60 DGE WINDGUARD (SIDE PIECE)	2
5	1243637	SCR, FLG, HEX .38-16X1.25 G8 ZY	22
6	0120023	MCNEILUS CNG SYSTEM ONLY (SCR, FLGS, HEX .25-20X1.00 CH ZC)	5
	1243637	AGILITY CNG SYSTEM ONLY (SCR, FLG, HEX .38-16X1.25 G8 ZY)	4

Procedure:

1. Two people are required to perform this procedure.
2. Place vehicle on a flat surface, block truck tires, disconnect vehicle battery (see information below for disconnecting the battery), and observe all safety conditions.

Battery Disconnect Procedures

Battery Disconnect Switch

- If the vehicle is equipped with a battery disconnect switch, it is located near the battery box. Use the battery disconnect switch when performing any maintenance so the vehicle cannot be accidentally started.
 1. Turn the battery disconnect switch (Figure A, Item 1) counterclockwise so the hole on the switch aligns with the hole in the bracket (Figure A, Item 2).
 2. Install the safety lockout device ring (Figure B, Item 1) through the holes on the battery disconnect switch and the bracket.
 3. Install a padlock (Figure B, Item 2) onto the safety lockout device ring, lock it, and put the key in your pocket. If more than one person is working on the vehicle, each person must install his or her own padlock.

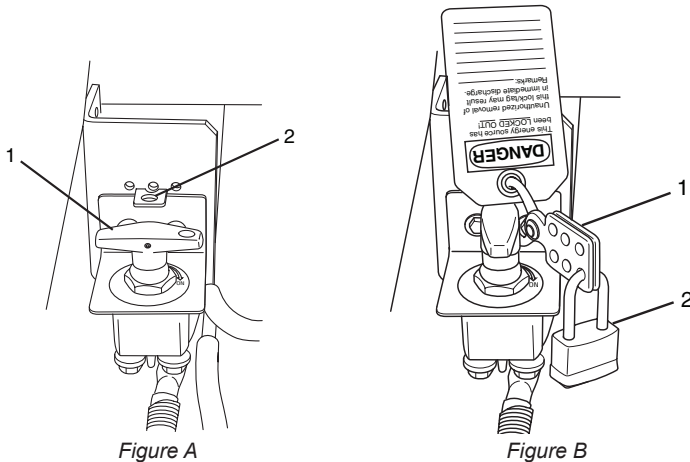

Battery Cables

- If the vehicle is not equipped with a battery disconnect switch, disconnect the negative (black) battery cable first, then the positive (red) cable.

⚠ WARNING

For trucks without a battery disconnect switch, to prevent accidental vehicle start-up, which could cause death or serious injury, disconnect battery cables (negative cable first) before proceeding.

Disconnect negative (-) battery cable first. If positive (+) cable should contact ground with negative (-) cable connected, the resulting sparks can cause a battery explosion, which could result in death or serious injury.

3. Remove and discard the existing refuse deflector and hardware (Figure 1).

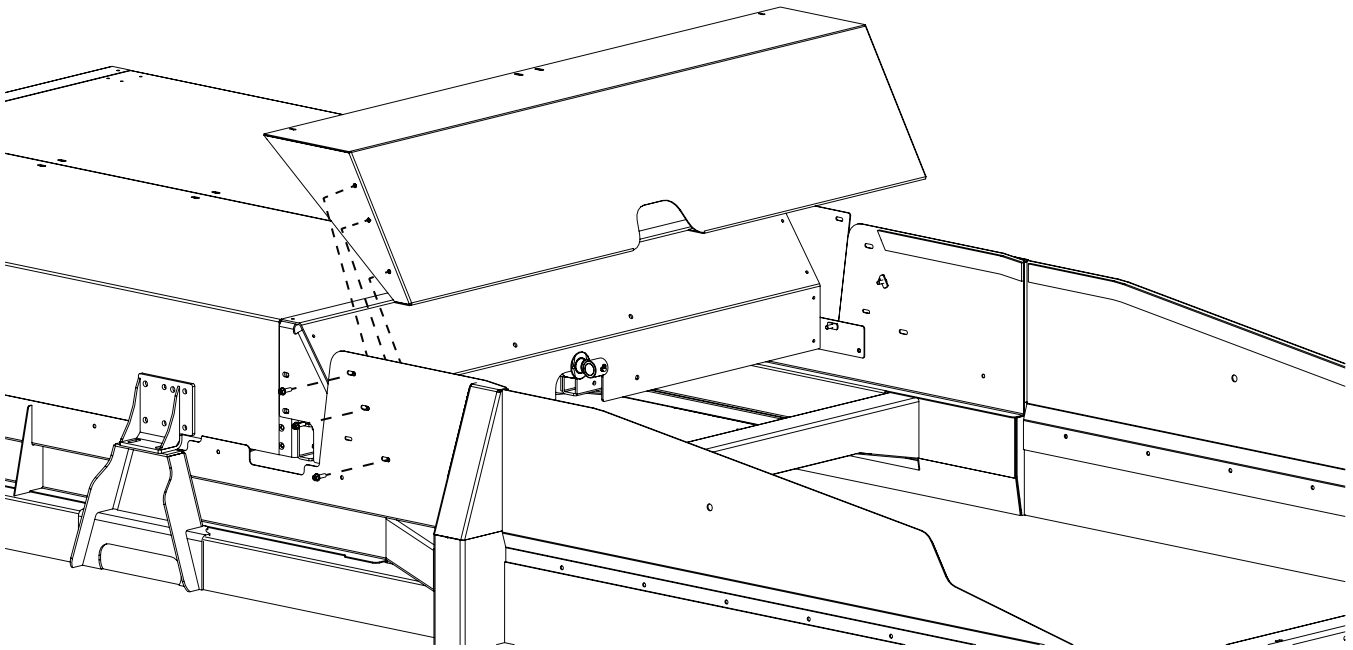

Figure 1

4. Starting on one side of the vehicle, install the rectangle cover piece ensuring the weld nuts are to the inside (Figure 2, Item 1). **NOTE:** Street side (PN 1572664) and curb side (PN 1572666) have different cover pieces.
5. Install (2) bolts (PN 1243637) to attach the cover piece to the vehicle windguard (Figure 2, Item 2).

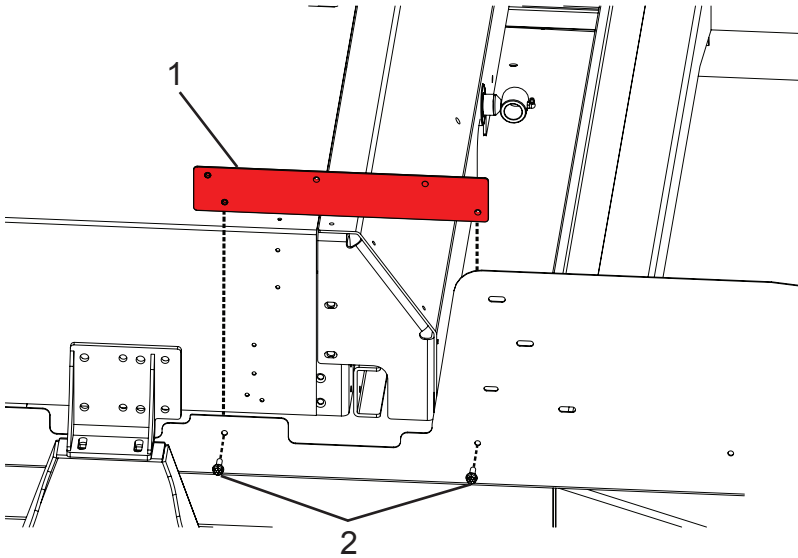

Figure 2

6. Use a torque wrench to torque bolts to 33 ft.-lbs.
7. Repeat Steps 4 through 6 on the opposite side of the vehicle with the appropriate rectangle cover piece.

8. Attach the slings and overhead crane to the refuse deflector weldment cover piece (Figure 3) (PN 1572662).
9. Move the refuse deflector weldment cover piece into position at the roof mounted CNG system and line up the refuse deflector weldment cover piece so that you can install bolts in the three diagonal bolt slots on either side of the vehicle (Figure 3).

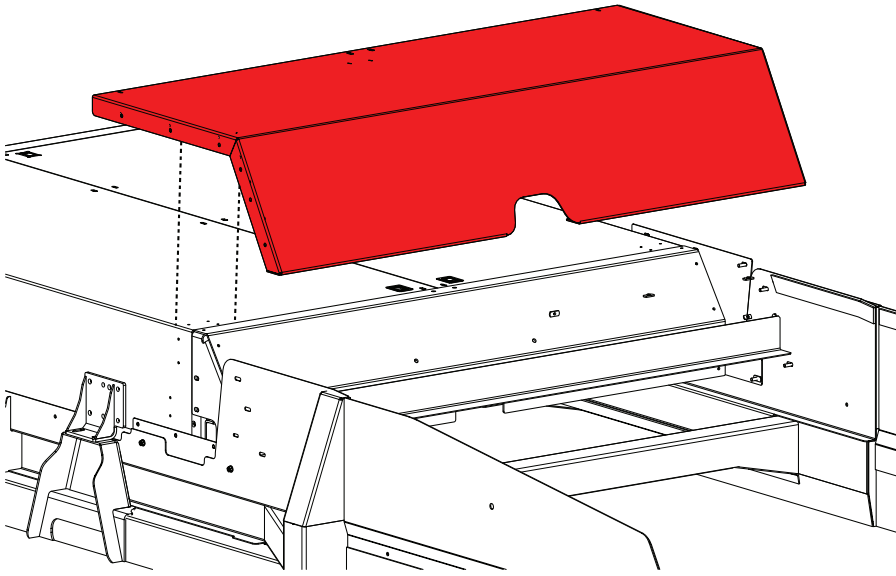

Figure 3

10. Install bolts in the three diagonal bolt slots on both sides to secure the refuse deflector weldment cover piece to the windguards (Figure 4).
11. Use a torque wrench to torque the bolts to 33 ft.-lbs.

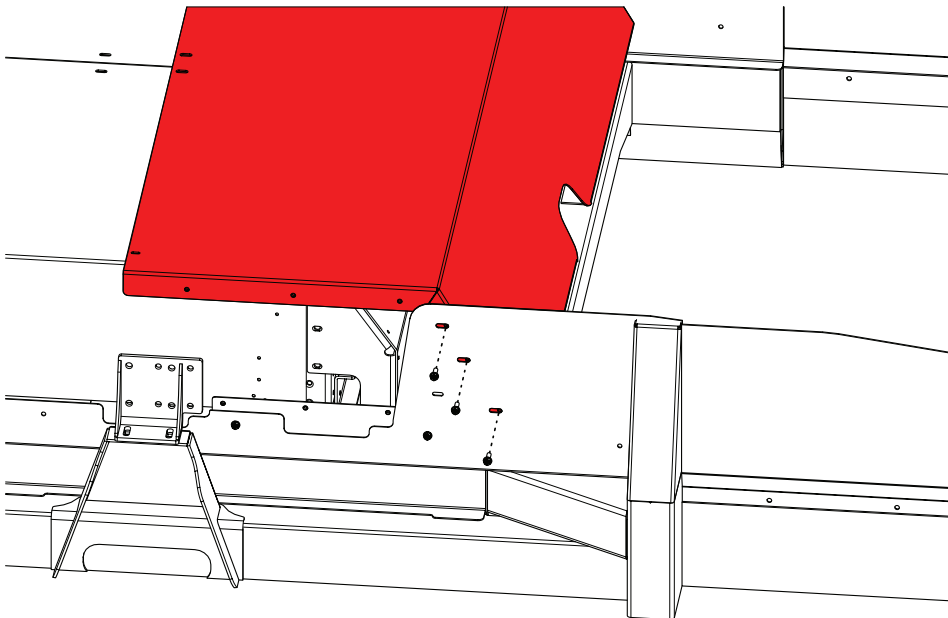

Figure 4

12. Starting on one side of the vehicle, install the large side cover piece (PN 1572667) so that it will attach to the refuse deflector weldment cover piece in three areas and to the rectangle cover pieces in three areas (Figure 5). **NOTE:** The side cover pieces go on the outside of the refuse deflector weldment cover and the rectangle cover pieces.
13. Use a torque wrench to torque the bolts to 33 ft.-lbs.

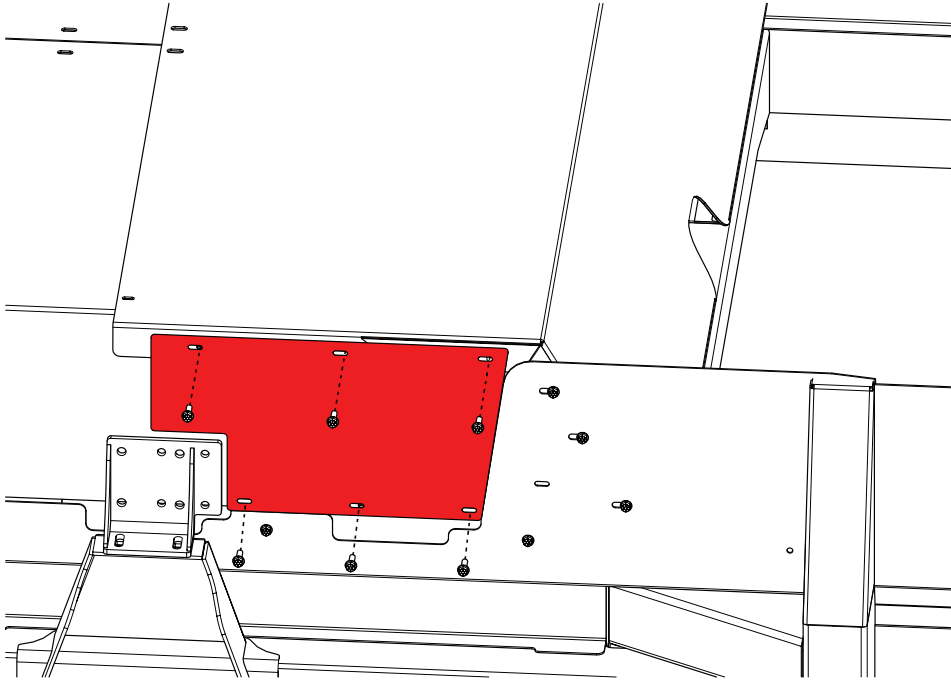

Figure 5

14. Repeat Steps 12 and 13 on the other side of the truck to install the second large side cover piece (PN 1572667).
15. Install the correct bolts across the top of weldment cover piece. The number of bolts and specific holes used will be based on if the CNG system is McNeilus or Agility. Figure 6 (McNeilus) and Figure 7 (Agility) detail the specific holes for each system.
 - McNeilus CNG system = Bolts PN 0120023, quantity 5
 - Agility CNG system = Bolts PN 1243637, quantity 4
16. Use a torque wrench to torque the McNeilus bolts to 9 ft.-lbs.
 - Use a torque wrench to torque the Agility bolts to 23 ft.-lbs.

McNeilus CNG System

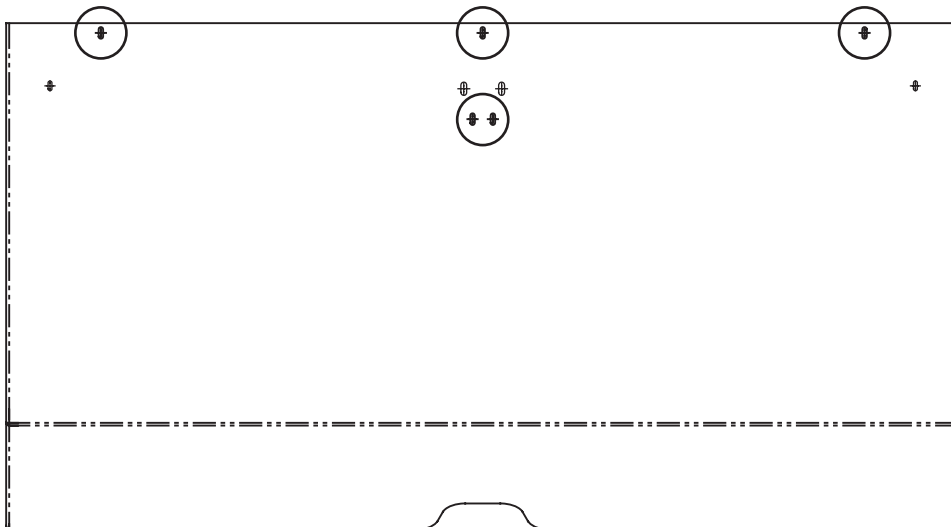

Figure 6

Agility CNG System

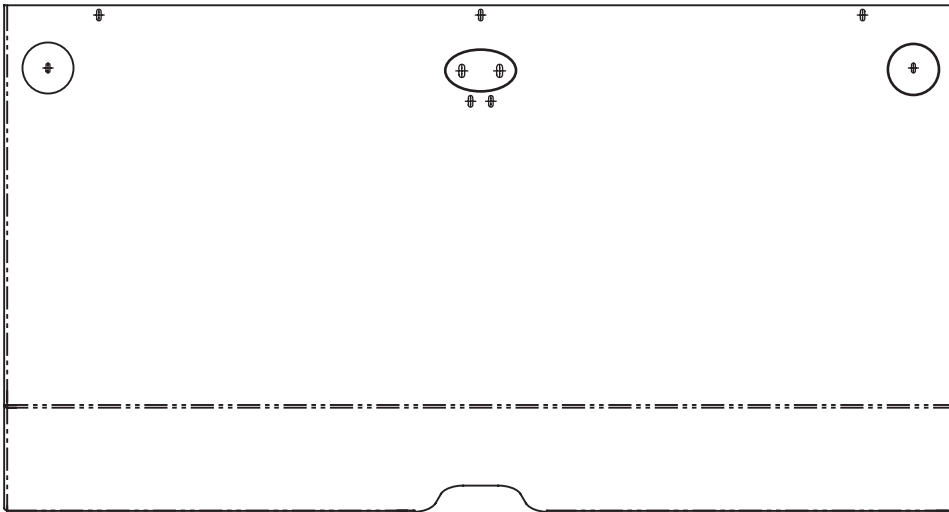

Figure 7

17. Installation procedure is complete.
18. Reconnect the vehicle's battery and remove your company's Lockout/Tagout procedure. If your company does not have a Lockout/Tagout procedure, follow OSHA 1910.147 and 1910.146 Confined Space as appropriate.
19. Activate the top door from the cab control box and run it open and closed a few times to ensure it clears the refuse deflector weldment.
 - If the top door does not function or hits the deflector weldment, call a McNeilus National Service Representative at 888-686-7278 for assistance.

Continuous Improvement:

The change included in this document is part of the McNeilus Continuous Improvement Process.

McNeilus's quality policy is providing customer satisfaction through innovative products, dedicated service, and a constant focus on continuous improvement.



(888) 686-7278

www.streetsmartparts.com