

January 31, 2018

08123 Version 8

Warranty Extension: MIL Comes On With DTCs P0301 thru P0304

Supersedes 13-082, dated May 18, 2015, to revise the information highlighted in **yellow**.

AFFECTED VEHICLES

Year	Model	Trim	VIN Range
2009–13	Pilot	ALL	Check the iN VIN Status for Eligibility

REVISION SUMMARY

Additional NOTES added under REPAIR PROCEDURE.

CORRECTIVE ACTION

2009–11 Models: Complete the diagnosis procedure and if necessary, update the PCM software and replace the affected spark plugs. If the vehicle returns after the updated PCM software and spark plug replacement have been installed, clean the pistons and replace the pistons rings along with the spark plugs (**Procedure B**).

NOTE: Make sure the software update has been completed, spark plugs replaced (**Procedure A**), and the vehicle returned to the customer before making any additional repairs. **Failure to do so will result in claim review by your DPSM and possible debit.**

2012–13 Models: Complete the diagnosis procedure and if necessary, clean the pistons and replace the pistons rings along with the spark plugs (**Procedure B**).

BACKGROUND

American Honda is announcing a powertrain warranty extension as a result of a settlement of a class action captioned, *Soto et al. v. American Honda Motor Co., Inc.*, Case No. 3:12-cv-1377-SI (N.D. Cal.).

The piston rings on certain cylinders may rotate and align, which can lead to spark plug fouling. This can set DTCs P0301 No. 1 cylinder misfire detected, P0302 No. 2 cylinder misfire detected, P0303 No. 3 cylinder misfire detected, P0304 No. 4 cylinder misfire detected, and cause the MIL to come on.

American Honda is extending the powertrain warranty to cover repairs related to engine misfire (that triggers DTCs P0301 through P0304) to 8 years with unlimited mileage from the original date of purchase and has settled a class action based on this remedial measure.

This warranty extension does not apply to any vehicle that has ever been declared a total loss or sold for salvage by a financial institution or insurer, or has a branded or similar title under any state's law.

CUSTOMER NOTIFICATION

Owners of affected vehicles were sent a class action settlement notice regarding this warranty extension starting in October 2013.

Before doing work on a vehicle, verify its eligibility by doing an iN VIN status inquiry.

Refer customers seeking information about settlement benefits to www.enginemisfiresettlement.com, or instruct them to call **888-888-3082**.

CUSTOMER INFORMATION: The information in this bulletin is intended for use only by skilled technicians who have the proper tools, equipment, and training to correctly and safely maintain your vehicle. These procedures should not be attempted by "do-it-yourselfers," and you should not assume this bulletin applies to your vehicle, or that your vehicle has the condition described. To determine whether this information applies, contact an authorized Honda automobile dealer.

DIAGNOSIS

1. Connect the HDS and check for the following DTCs: P0301 No. 1 Cylinder Misfire Detected, P0302 No. 2 Cylinder Misfire Detected, P0303 No. 3 Cylinder Misfire Detected, P0304 No. 4 Cylinder Misfire Detected.

Are any of these DTCs stored?

YES – Go to step 2.

NO – Stop. This bulletin does not apply. Continue with normal troubleshooting.

2. Remove and check the spark plug(s) on the affected cylinders (example: if P0301 is stored, check the spark plug on cylinder No. 1).

Are the spark plug(s) fouled?

YES – Go to step 3.

NO – Stop. This bulletin does not apply. Continue with normal troubleshooting.

GOOD



NO GOOD

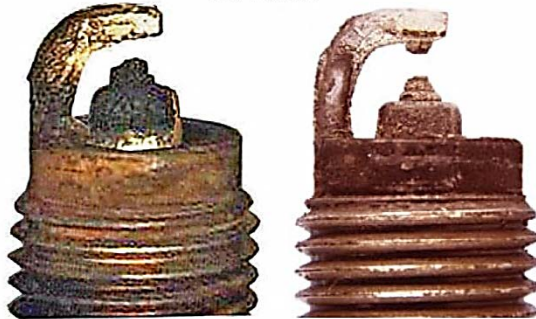

3. Check the PCM software version P/N located above the **PGM FI Data List**. All 2012–13 vehicles are up to date, go directly to step 4.

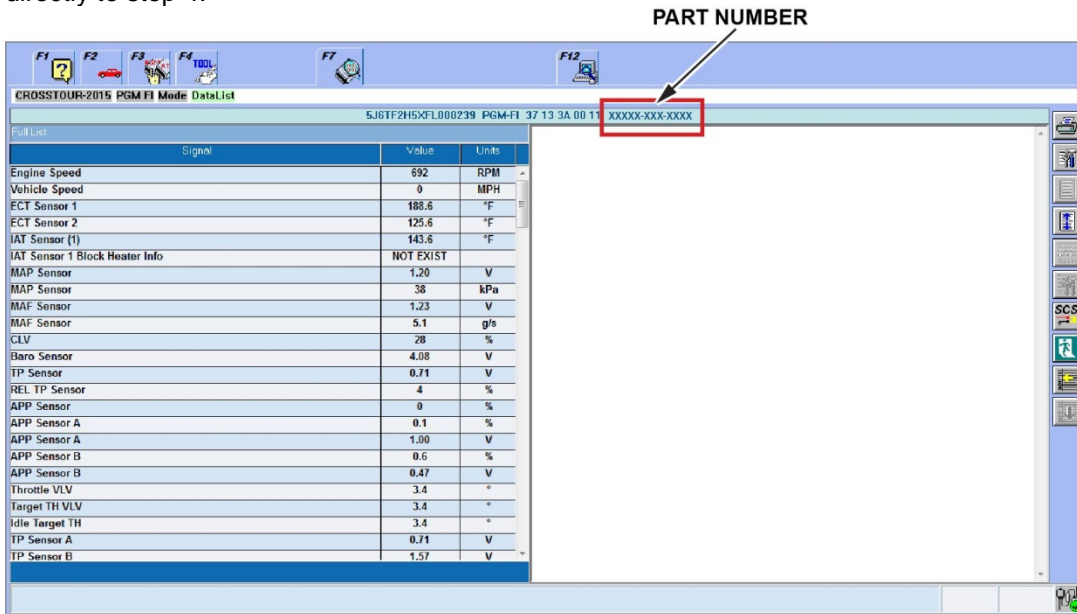

Year/Model	Program ID (or later)	Program P/N (or later)
2009–10 Pilot (2WD)	N0A570	37805-RN0-A57
2009–10 Pilot (4WD)	N0A770	37805-RN0-A77
2011 Pilot (2WD)	N0A630	37805-RN0-A63
2011 Pilot (4WD)	N0A830	37805-RN0-A83
2012–13 Pilot (ALL)	Software Updated from Factory	

Is the PCM Program ID and/or Program P/N the same or newer than what is listed above, 2009–11 model years only?

NO – The PCM software needs to be updated. Go to REPAIR PROCEDURE A.

YES – The correct software is installed. The piston rings on select cylinders need to be replaced. Go to step 4.

IMPORTANT NOTICE: The PCM software must first be updated with the correct version, replace spark plugs and the vehicle returned to the customer. Piston cleaning and piston ring replacement, as described below, should only be done after the customer has returned with a second failure or if the vehicle’s software is the correct version. **Failure to follow this process correctly may result in a full debit of the warranty claim to your dealer.**

4. Note which DTCs are stored in the vehicle.

Does the vehicle have DTC P0304 stored? (Any combination of DTCs P0301, P0302, P0303, P0304 may also be stored.)

YES – Go to REPAIR PROCEDURE B for the cylinders listed, Cylinders 1–4: Clean the pistons, replace the piston rings, and replace the spark plugs.

NO – Go to REPAIR PROCEDURE B for the cylinders listed below:

- Cylinder 1–3: Clean the pistons and replace the pistons rings.
- Cylinder 1–4: Replace the spark plugs.

WARRANTY CLAIM INFORMATION

2009–11 Models: Confirm PCM Software is or has been updated with the correct version, spark plugs 1–4 have been replaced and the vehicle returned to the customer (**Procedure A**). Piston cleaning and piston ring replacement along with the spark plugs, should be only be done after the customer has returned with a second failure or if the vehicles software is the correct version (**Procedure B**). **Failure to follow this process correctly may result in a full debit of the warranty claim to your dealer.**

2012–13 Models: Are equipped with updated software from the factory, no software updated is needed. Piston cleaning and piston ring replacement along with the spark plugs should be done (**Procedure B**).

FLAT RATE NOTE: The procedure in this bulletin is different than the service manual. This procedure does not require the complete removal of the power steering pump, catalytic converter(s), engine and transmission, or the crankshaft. As a result, the operation number is unique and the FRT is reduced (**Procedure B**).

2009–11 Pilot

OP#	Description	Flat Rate Time	Template ID	Failed Part Number
1171G9	2009–11 Pilot: Procedure A Update the PCM and replace spark plugs 1–4 (includes diagnosis).	0.5 hr	13-082A	13011–R70–A02
1171H0	2009–11 Pilot: Procedure B Replace piston rings 1–3 and replace spark plugs 1–4 (includes diagnosis).	9.1 hrs		13011–R70–A02
1171H0B	2009–11 Pilot: Add if replacing piston rings on cylinder 4.	1.9 hrs		13011–R70–A02

2012–13 Pilot

OP#	Description	Flat Rate Time	Failed Part Number
1171H0	2012–13 Pilot: Replace piston rings 1–3 and replace spark plugs 1–4 (includes diagnosis).	9.1 hrs	13011–5G0–A01
1171H0B	2012–13 Pilot: Add if replacing piston rings on cylinder 4.	1.9 hrs	13011–5G0–A01

Defect Code: 5V500

Symptom Code: JC000

Skill Level: Repair Technician

PARTS INFORMATION

NOTE: Do the DIAGNOSIS first to determine which cylinders you will need to repair.

REPAIR PROCEDURE A – SOFTWARE UPDATE AND CYLINDERS 1–4 SPARK PLUG REPLACEMENT

Required Parts

Part Name	Part Number	Quantity
Spark Plugs (2009–11 All)	12290-R70-A01	4
Spark plugs (2012–13 All)	12290-R71-L01	4

REPAIR PROCEDURE B – PISTON CLEANING AND RING REPLACEMENT

Required Parts

Part Name	Part Number	Cyl 1-3	Cyl 1-4
Cyl. Gasket (Fr Cylinder Head)	12251-R70-A01		1
Cyl. Gasket (Rr Cylinder Head)	12261-R70-A01	1	1
Drain Washer 14 mm	94109-14000	1	1
EGR Pipe Gasket A	18716-R70-A01	1	1
EGR Pipe Gasket B	18719-R70-A01	1	1
Ex. Chamber Gasket	18115-R70-A01	1	2
Ex. Pipe Gasket	18212-SA7-003	2	2
Head Gasket Fr (Valve Cover)	12030-R70-A00		1
Head Gasket Rr. (Valve Cover)	12050-R70-A00	1	1
In. Manifold Gasket (Intake Top Cover)	17146-R70-A01	1	1
In. Manifold Gasket (2009–10 2WD)	17105-RCA-A01	1	1
In. Manifold Gasket (2009–13 4WD & 2011–13 2WD)	17105-RCJ-A01	1	1
Oil Filter	15400-PLM-A02	1	1
O-ring (7.47 mm x 3.6 mm)	91301-PLC-000	2	2
O-ring (31.2 mm x 4.1 mm)	91314-PH7-003	2	2
Piston Ring Set	13011-5G0-A02	3	4
Pre-chamber Gasket	18393-SDB-A00	1	1
Self-locking Nut (8 mm)	90212-RCA-A01	4	8
Self-locking Nut (10 mm)	90212-SA5-003	9	9
Spark Plug (2009–11 All)	12290-R70-A01	4	4
Spark plug (2012–13 All)	12290-R71-L01	4	4
Strainer O-ring	15221-RYE-A01	1	1
Timing Belt Bolt	14551-RCA-A01	1	1
Water Gasket Fr.	19411-P8A-A03	1	1
Water Gasket Rr.	19412-P8A-A02	1	1

Replaced Parts as Needed for Repair Procedure B

Part Name	Part Number	Cyl 1-3	Cyl 1-4
Connecting Rod Bolt (May require Up to 6 bolts per cylinder head)	13204-P8A-A01	6	8
Washer-Bolt (12 x 163) (May require up to 8 bolts per cylinder head)	90005-PAA-A01	8	16

REQUIRED MATERIALS – REPAIR PROCEDURE B

Material Description	Part Number	Quantity
Honda Long-Life Antifreeze/Coolant Type 2	OL999–9011	3 gallons
Genuine Honda Motor Oil 0W–20	08798–9036	6 quarts
Genuine Honda Motor Oil 5W–20 (if requested) (2009-11)	08798–9032	6 quarts
Hondabond HT (1 Tube Repairs 5 Vehicles)	08718–0004	1 tube
Genuine Honda Throttle Plate Cleaner	08700–9204	
Nylon Parts Cleaning Brush	(commercially available)	
5/16 ID Flexible Hose	(commercially available)	

TOOL INFORMATION – REPAIR PROCEDURE B

Tool Description	Tool Number	Quantity
Piston Ring Groove Cleaner	07AAZ–TA5A100	1

REPAIR PROCEDURE A – SOFTWARE UPDATE AND CYLINDERS 1–4 SPARK PLUG REPLACEMENT

1. For 2009–11 models only, update the PCM software. Refer to Service Bulletin 01-023, *Updating Control Units/Modules*.
2. Replace spark plugs on cylinders 1–4, then return the vehicle to the customer.

REPAIR PROCEDURE B – PISTON CLEANING AND RING REPLACEMENT

2009–11 Models: Confirm PCM software is or has been updated with the correct version, spark plugs 1–4 have been replaced and the vehicle returned to the customer (**Procedure A**). Piston cleaning and piston ring replacement along with the spark plugs should only be done after customer has returned with a second failure or if the vehicles software is the correct version (**Procedure B**). **Failure to follow this process correctly may result in a full debit of the warranty claim to your dealer.**

2012–13 Models: Are equipped with updated software from the factory, no software update is needed. Piston cleaning and piston ring replacement along with the spark plugs should only be done after the diagnosis of the spark plugs has concluded that (**Procedure B**) is required.

The following service manual procedures have been used in full or in part within this service bulletin. For more detail on these procedures, and torque specifications for some components, refer to the appropriate electronic service manual.

- Battery Terminal Disconnection and Reconnection
- Fuel Pressure Relieving
- Fuel Line/Quick-Connect Fitting Removal
- Air Cleaner Removal/Installation
- Splash Shield Replacement
- Drive Belt Removal/Installation
- Engine Oil Replacement
- Coolant Replacement
- Hydraulic Power Steering Fluid Check/Replacement
- Intake Manifold Removal and Installation
- Timing Belt Removal and Installation
- Warm Up-TWC Removal/Installation
- Cylinder Head Cover Removal
- Cylinder Head Removal and Installation
- Piston Ring Replacement
- PCM Idle Learn Procedure
- Valve Adjustment

Piston Removal Procedure

- Use fender covers to avoid damaging painted surfaces.
 - To avoid damaging any wires and terminals, unplug the circuit connectors carefully while holding the connector portion.
 - Mark all the circuits and hoses to avoid misconnection. Make sure they do not contact other circuit wiring, hoses, or interfere with other parts.
1. Relieve the fuel pressure.
 2. Remove both front wheels so you can fully lower the vehicle.
 3. Remove the intake duct.

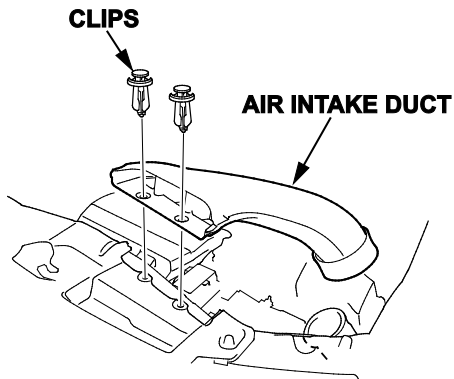

4. Do the battery removal procedure.
5. Disconnect the fuel feed hose line at the bulkhead.

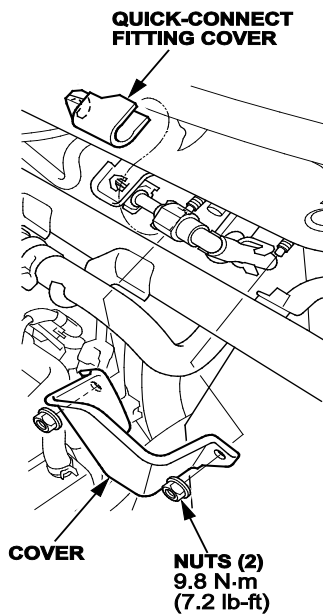

6. Remove the engine cover.

ENGINE COVER

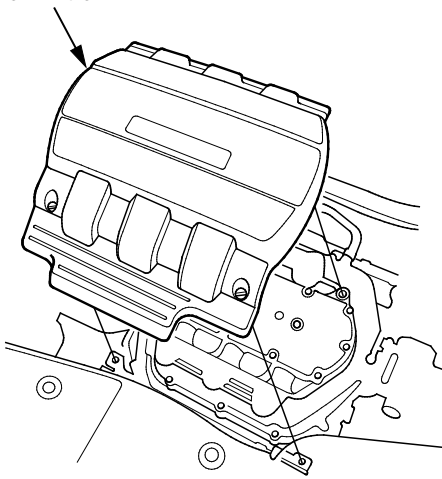

7. Remove the radiator cap.
8. Raise the vehicle.
9. Remove the front splash shield.

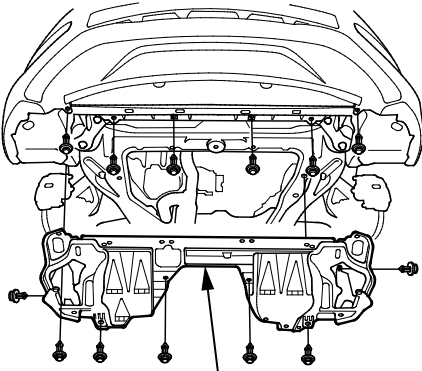

FRONT SPLASH SHIELD

10. Drain the engine oil.
11. Loosen the drain plug on the radiator, and drain the coolant.

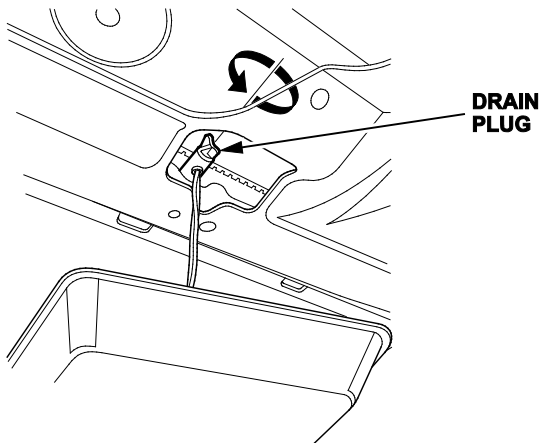

- Install a 5/16th inner diameter rubber hose on the drain bolt at the rear of the engine block, loosen the drain bolt, and drain all remaining coolant. Then disconnect the oil pressure switch connector.

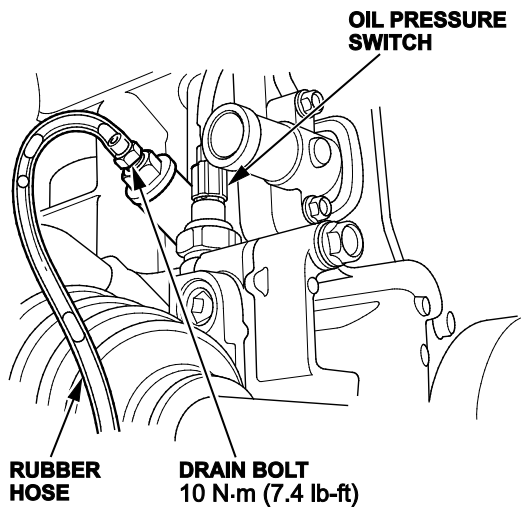

- Remove the subframe stiffener.

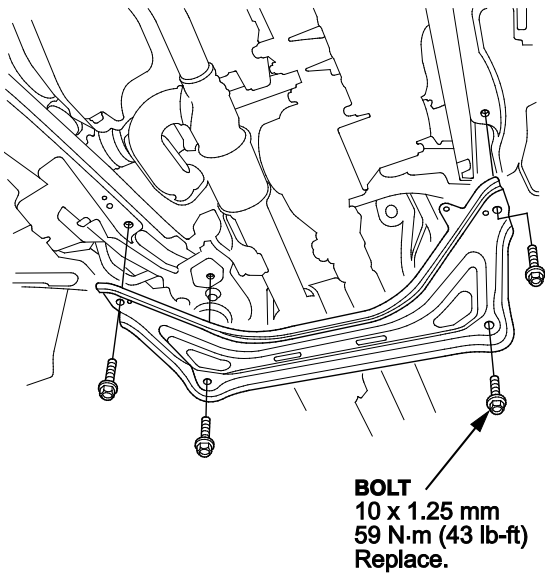

- Remove exhaust pipe A.

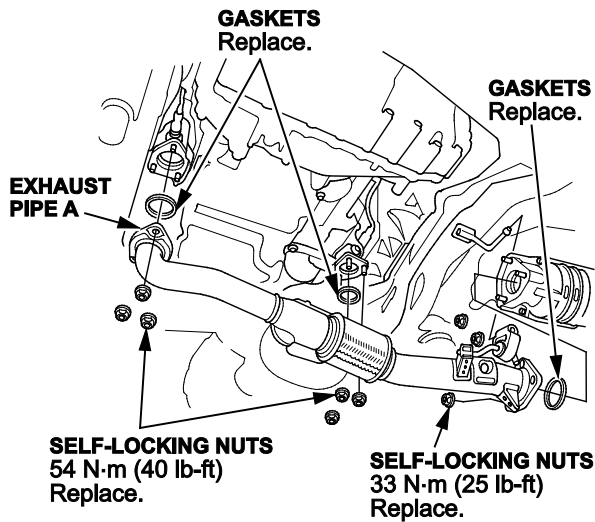

15. Depending on the diagnosis, remove the appropriate WU-TWC support bracket bolts.
16. Remove the EGR lower pipe nuts.
17. Remove the crankshaft pulley bolt but not the pulley.

NOTE: Make sure to apply new oil to the bolt flange and threads before reinstallation.

X : Remove any oil

O : Clean

● : Lubricate with new engine oil

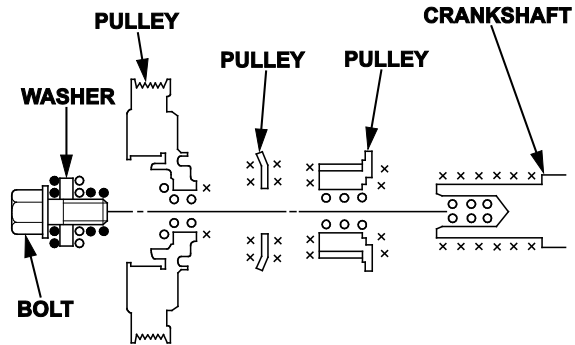

18. Lower the vehicle.
19. Disconnect the MAP sensor connector and the breather pipe, then remove the intake air duct.

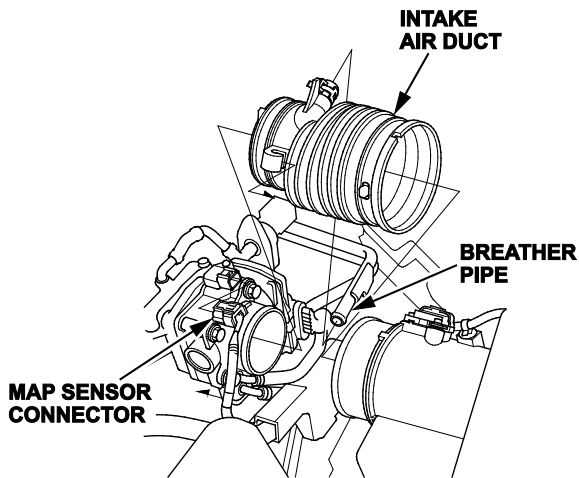

20. Disconnect the throttle body connector, the EVAP canister purge valve connector, the EVAP hose, the brake booster vacuum hose, and the vacuum hose.

21. Disconnect and plug the water bypass hoses.

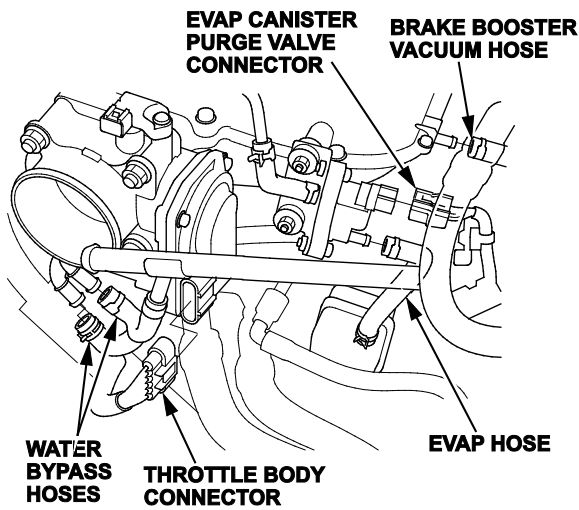

22. Remove the drive belt.

23. Remove the drive belt auto-tensioner.

24. Remove the power steering pump bolts, the power steering bracket then secure the power steering pump out of the way.

NOTE: Do not remove any of the hoses.

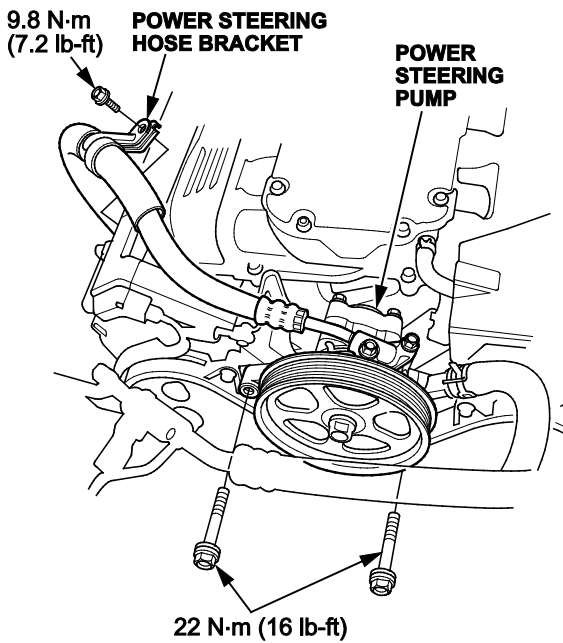

25. Remove the engine harness holder bolt on the side engine mount.

26. Set the engine to TDC cylinder one.

27. Remove the crankshaft pulley.

28. Remove the timing belt.

29. Remove the timing belt idler pulley.

30. Remove the engine intake upper cover bolts and nuts. Then remove the cover and the PCV hose.

SPECIFIED TORQUE
6 x 1.0 mm
12 N·m (8.7 lb-ft)

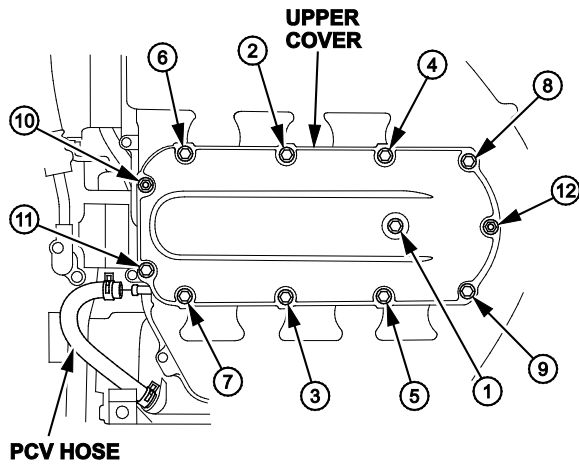

31. Remove the intake manifold bolts and nuts in three steps, then remove the intake manifold.

SPECIFIED TORQUE
22 N·m (16 lb-ft)

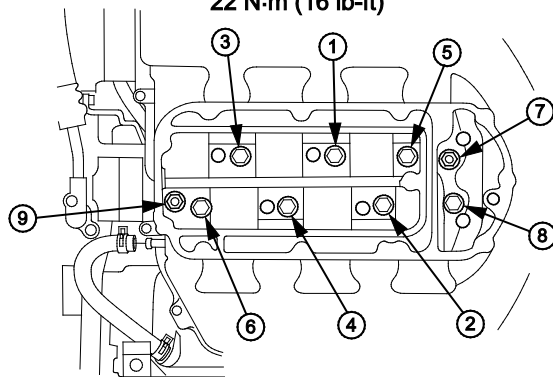

32. Remove the PCM cover and connectors. Disconnect the battery cables from the underhood fuse box.

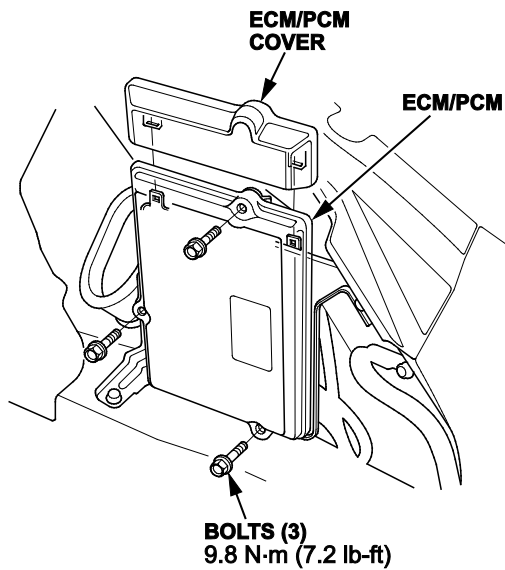

33. Remove the appropriate Ignition coils based on the diagnosis.

NOTE: Depending on the diagnosis, you will either have to remove the rear bank ignition coils or both ignition coil banks.

FRONT

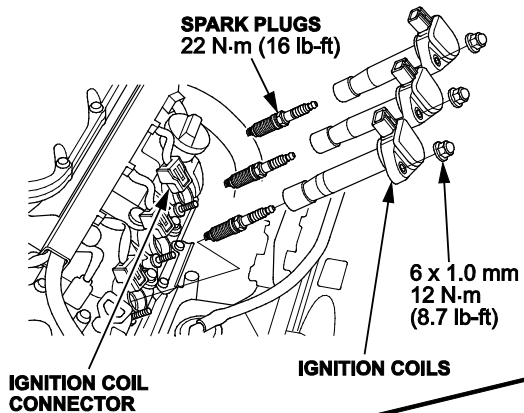

REAR

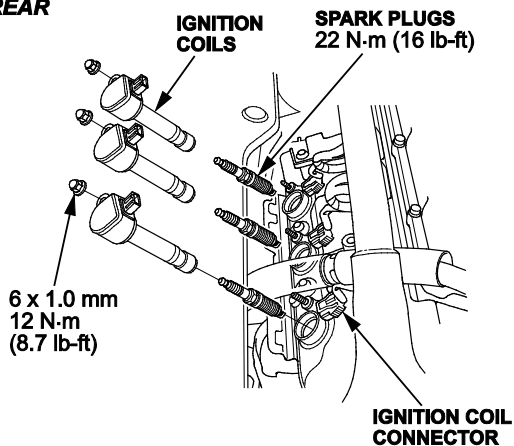

34. Depending on the diagnosis, remove some or all of the following components:

- ECT sensor connector
- Front rocker arm oil pressure switch connector
- Rear rocker arm oil pressure switch connector
- CMP sensor connector
- Front A/F sensor one connector
- Rear A/F sensor one connector
- Front secondary HO2S connector
- Rear secondary HO2S connector
- Rocker arm oil control solenoid A connector (bank one)
- Rocker arm oil control solenoid A connector (bank two)
- Rocker arm oil control solenoid B connector (bank one)
- Alternator connector and positive alternator cable
- A/C clutch switch connector
- EGR 5P valve connector
- Engine ground
- Knock sensor
- Fuel injector connectors and clips

35. Remove the quick-connect fitting cover, then disconnect the fuel feed hose.

**QUICK-CONNECT
FITTING COVER**

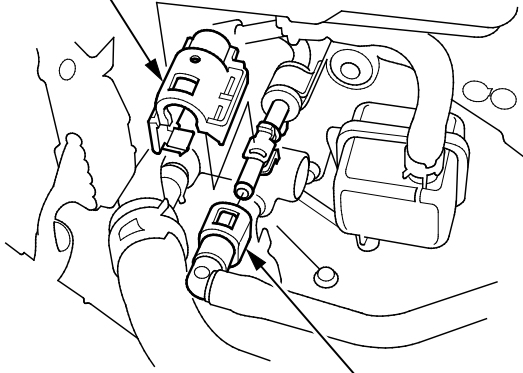

FUEL FEED HOSE

36. Remove the EVAP canister purge joint with the bracket.

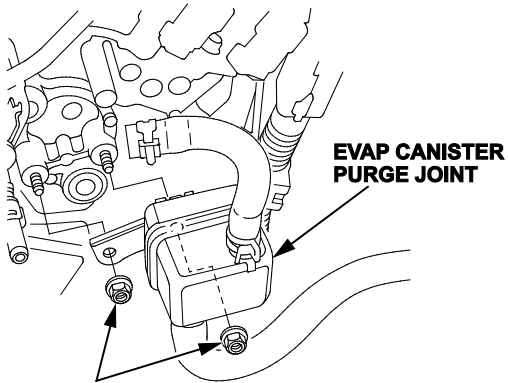

**EVAP CANISTER
PURGE JOINT**

12 N·m (8.7 lb-ft)

37. Remove the fuel rail connecting joint hose.

**MOUNTING BOLT
22 N·m (16 lb-ft)**

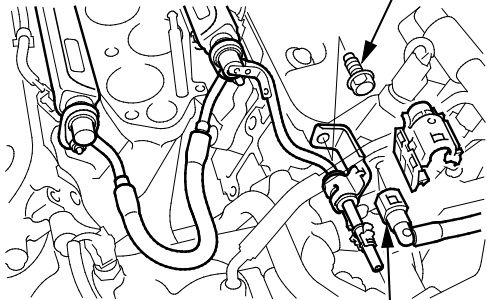

**QUICK-CONNECT
FITTING**

38. Remove the EGR pipe mounting bolts, then remove the EGR pipe.

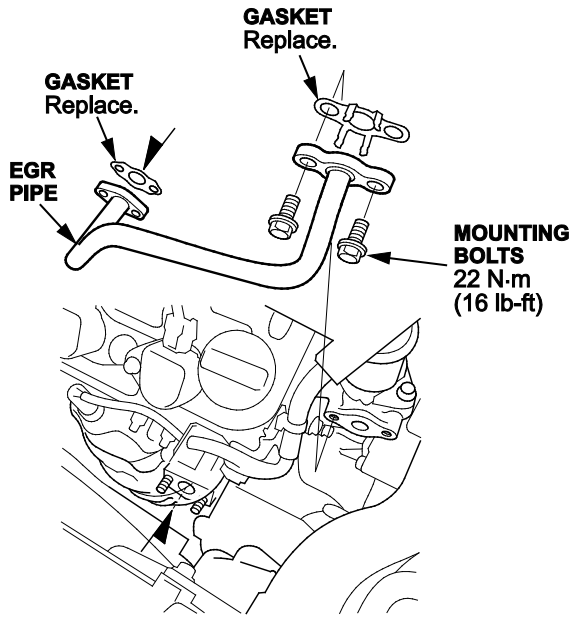

39. Separate the water passage from the heads.

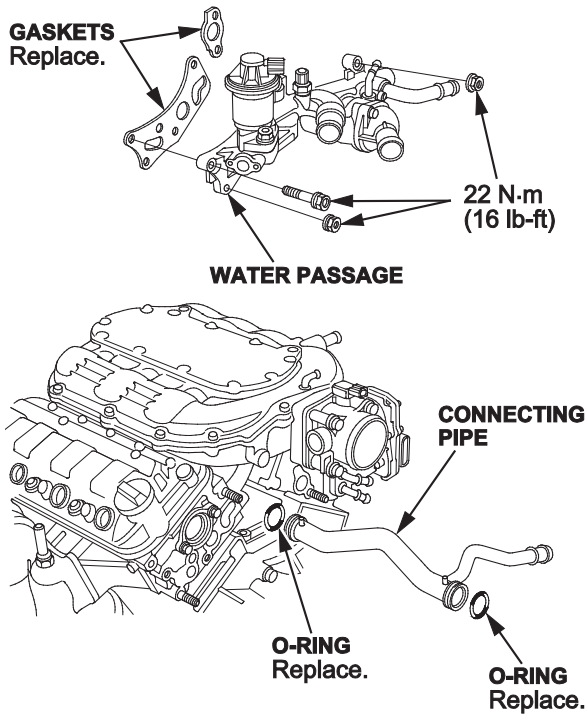

40. Remove the appropriate WU-TWC depending on diagnosis.

NOTE: Set the WU-TWC aside and cover the opening with shop towels to prevent coolant from entering.

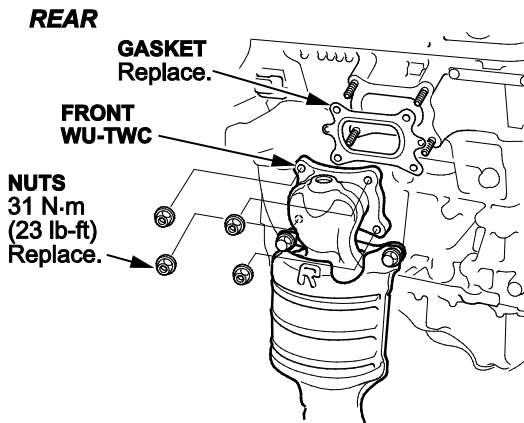
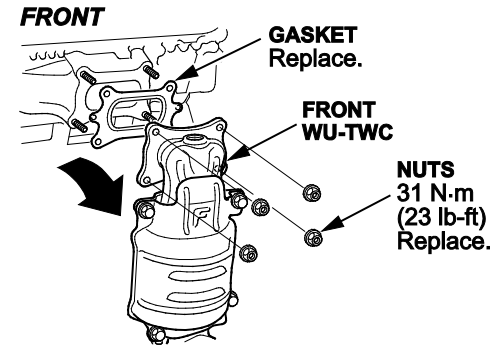

41. Remove the appropriate head with the injector base attached.

NOTE: Depending on diagnosis, you will remove the rear bank head or both heads.

FRONT

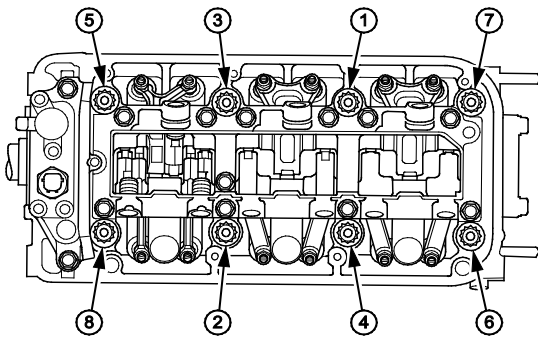

REAR

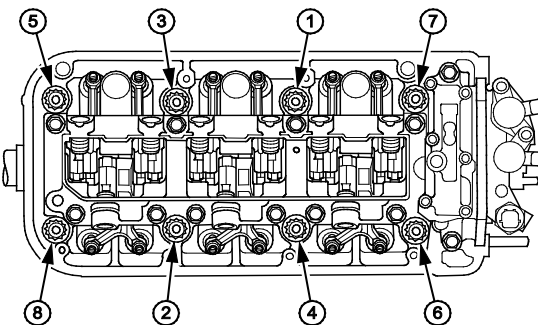

42. Measure the head bolts to determine if they need replacement. If either diameter is less than **11.3 mm (0.445 in)**, replace the cylinder head bolt.

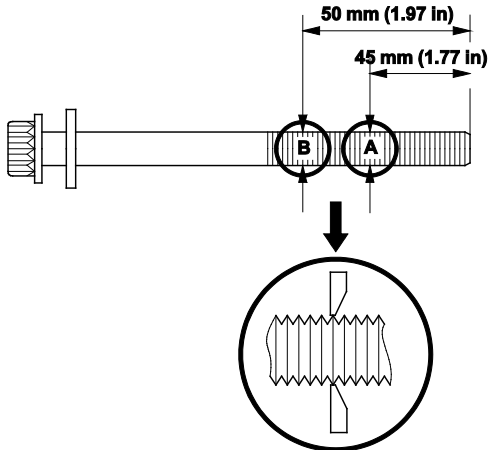

NOTE: Torque the bolts using the following steps for reinstallation.

- First step: torque the cylinder bolts in sequence to **29 N•m (22 lb-ft)**.
- Second step: tighten in sequence an additional **90 degrees**.
- Third step: tighten in sequence an additional **90 degrees**.
- If the bolts are new, tighten an additional **90 degrees**.

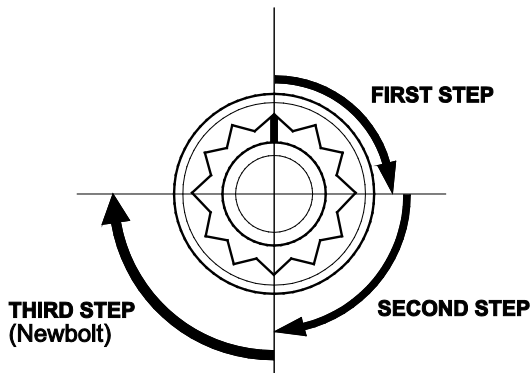

43. Raise the vehicle.
44. Remove the CKP sensor cover and bolts, then disconnect the CKP sensor connector.

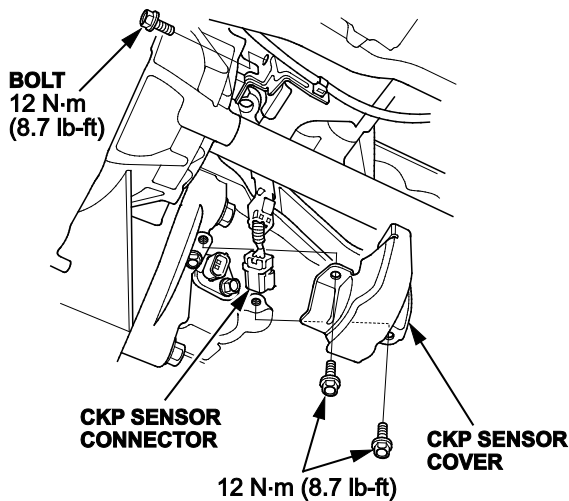

45. Remove the torque converter case cover and the four bolts securing the oil pan to the transmission.

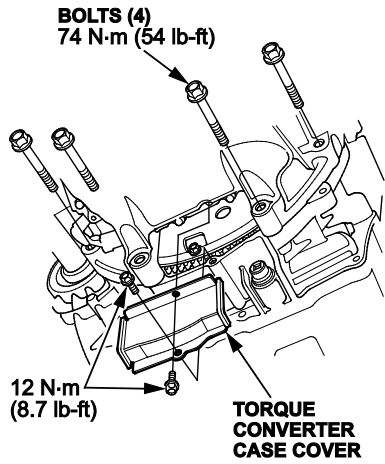

46. Remove all bolts securing the oil pan.

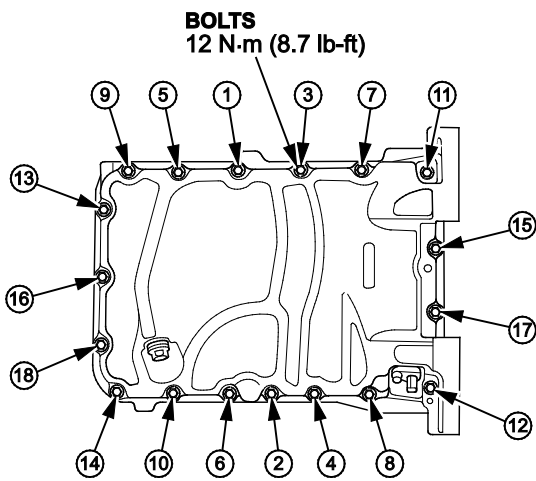

47. Using a flat blade screwdriver, separate the oil pan from the engine block in the areas shown.

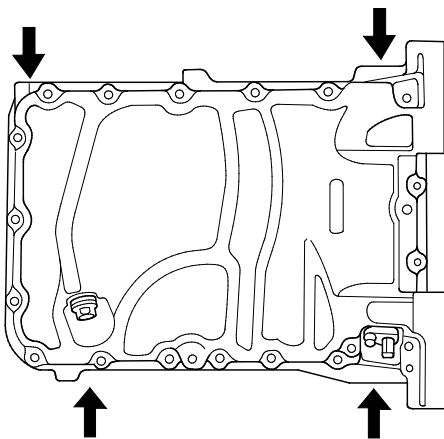

48. Remove the oil strainer and baffle plate.

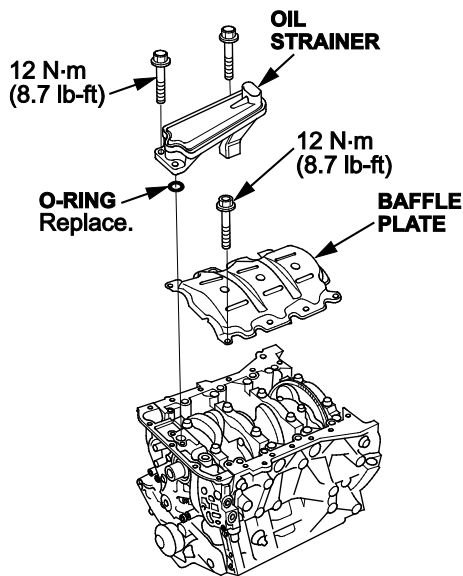

49. Lower the vehicle to a comfortable working height, and place a clean shop towel around the cylinder wall to prevent debris from entering the coolant passage.

50. Remove the appropriate piston depending on diagnosis, then go to PISTON CLEANING PROCEDURE.

NOTE:

- Before removing the rod caps, use a grease pencil or suitable marking pen to mark each cap and its corresponding connecting rod with the cylinder number it came from.
- Do not confuse the existing marking on the side of the connecting rod and rod cap with a cylinder number. They are just manufacturing marks referring to the size of the big end of the rod.
- Installing a rod cap incorrectly will result in engine knock and/or engine failure. Remove and mark one rod assembly at a time to make sure it is assembled correctly.
- When torquing the rod cap bolts, refer to the service information for details.
- Click [HERE](#) to go to the *Tech2Tech*® video "Tips When Working with Fracture Rods".

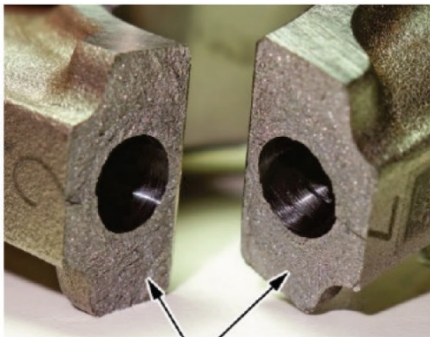

The uneven mating surfaces are uniquely matched and not interchangeable.

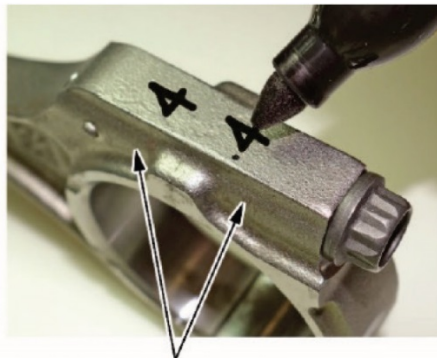

Mark the connecting rod and rod cap with the cylinder number.



These are manufacturing marks, and do not indicate the cylinder number.

Piston Cleaning and Ring Replacement Procedure

1. Remove the piston rings from the piston using a ring expander. Be careful not to damage the piston.

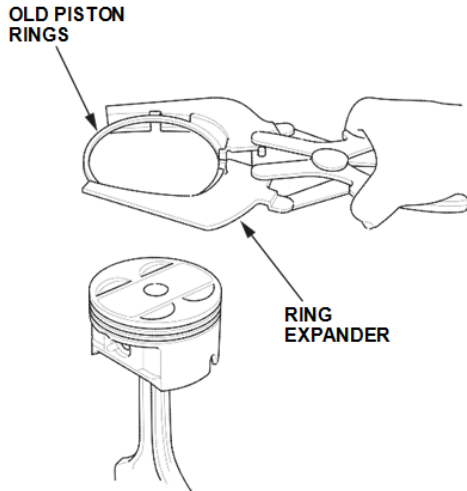

2. Spray the piston head and piston ring grooves thoroughly with Honda throttle plate cleaner.
3. While holding the piston upright in your left hand, take the piston ring groove cleaner tool in your right hand and line up the cleaner tool guides with the second (middle) piston ring groove.



4. Press the handle on the piston ring groove cleaner tool and slide the cleaning bit onto the appropriate piston ring grooves.



5. Once the cleaning bit is in the appropriate ring grooves of the piston, make sure the tool handle clicks into place.
NOTE: There is only one notch on the tool for the handle to engage.

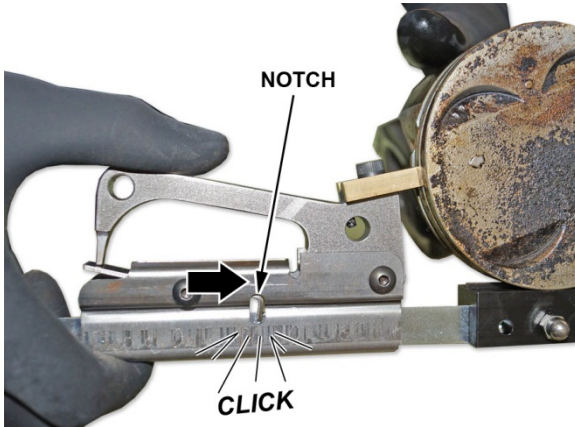

6. Hold the piston steady and rotate the tool counter-clockwise five to six times to remove any carbon deposits in the piston ring grooves. **Do not** rotate the tool clockwise.

NOTE: You can watch this procedure in the *Tech2Tech* segment "How to Clean Piston Ring Grooves".



7. Remove the piston groove cleaning tool and clean off the carbon from the tool bit.
8. Finish cleaning the piston with throttle plate cleaner and the nylon brush. **Do not** use a steel wire brush.



NOTE: Below are some examples of before and after pictures. Depending on mileage and running conditions, the pistons will achieve different levels of cleanliness.

54K PISTON



87K PISTON

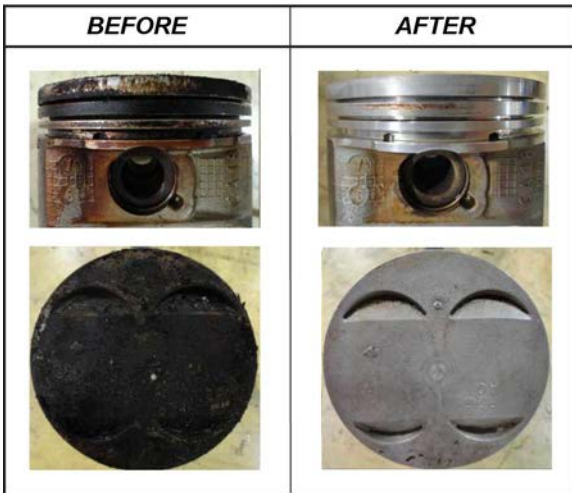

9. Install the piston rings as shown.

NOTE: The first (top) ring has a **1D** manufacturing mark and the second (middle) ring has an **SPR** manufacturing mark. The manufacturing marks must be facing upward.

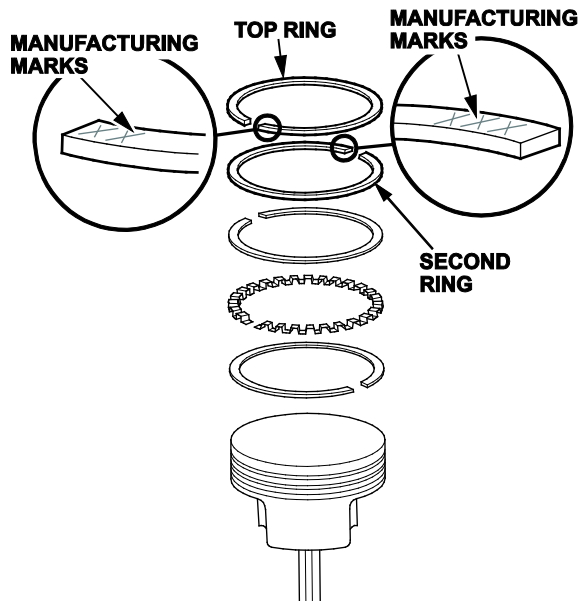
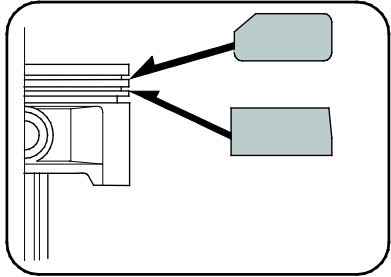

10. Position the ring end gaps as shown.

NOTE: If the ring gaps are not positioned correctly, excessive blowby may occur.

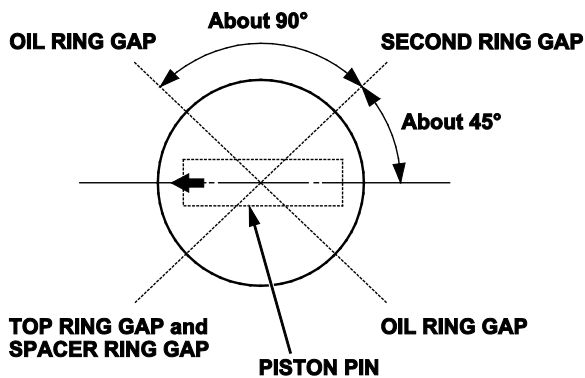

11. Apply new engine oil to the piston, the inside of the piston ring compressor, and the cylinder bore.

NOTE: Cylinder wall honing is NOT required for this repair.

12. Install the piston/connecting rod assembly into the cylinder bore with the arrow on top of the piston facing the timing belt side of the engine.

NOTE: Be careful not to damage the cylinder wall when installing the piston.

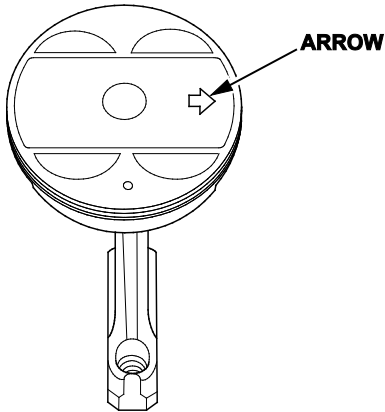

13. Measure the diameter of the connecting rod bolts to determine if they need replacement. Calculate the difference in diameter between point A and point B. It should not be more than **0–0.1 mm (0–0.004 in)**.

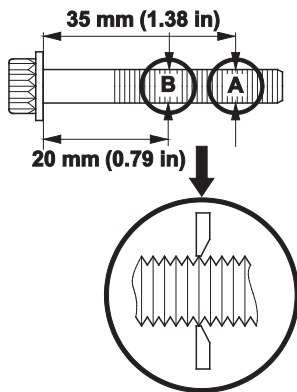

14. Apply new oil to the connecting rod bolt threads and flanges. Torque the bolts to **20 N•m (14 lb-ft)** then tighten the connecting rod bolts an additional **90 degrees**.

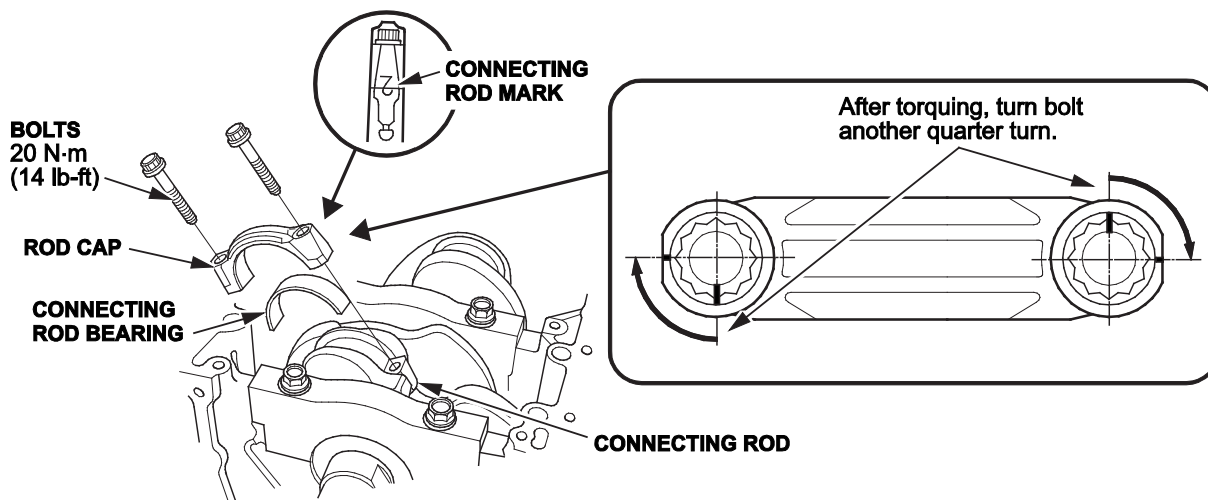

15. Reinstall the remaining components in the reverse order of removal.
16. Replace spark plugs 1–4.
17. Replace the oil filter and refill all fluids.
18. Do the idle learn procedure.

END.