

**January 24, 2018**

07647 Version 1

## 2013–2014 Accord: Engine Oil Consumption Exceeds Customer Expectations

### AFFECTED VEHICLES

Year	Model	Trim	VIN range
2013–14	Accord L4 (Except Hybrid)	ALL (Except Hybrid)	ALL

### SYMPTOM

Engine oil consumption exceeds customer expectations.

### POSSIBLE CAUSES

The oil control rings may become clogged with carbon deposits. These deposits restrict the ability to scrape and return oil from the cylinder walls to the crankcase.

### CORRECTIVE ACTION

Do the engine oil consumption test and, if necessary, replace the oil jets, all of the pistons, pins, rings, and spark plugs.

### PARTS INFORMATION - ANCILLARY LIST

NOTE: Needed for all repairs.

Part Name	Part Number	Quantity
Flange Bolt (10 X 30 mm)	90176-S5A-000	4
Flange Bolt (10 X 35 mm)	90163-SDA-A01	1
Flange Bolt (10 X 40 mm)	90169-TA0-A00	3
Flange Bolt (12 X 135 mm)	90161-TA2-H00	1
Flange Bolt (12 X 150 mm)	90162-TL1-E01	1
Flange Bolt (12 X 30 mm)	90176-SKN-000	3
Flange Bolt (12 X 40 mm)	90164-S5A-010	4
Flange Bolt (12 X 45 mm)	90161-SDA-A01	1
Flange Bolt (12 X 65 mm)	90168-TA0-A00	2
Flange Bolt (12 X 75 mm)	90163-TA0-A00	3
Flange Bolt (8 X 27 mm)	90001-RNA-A00	2
Spool Valve Filter Assembly	15815-5A2-A01	1
Oil Filter	15400-PLM-A01	1

**CUSTOMER INFORMATION:** The information in this bulletin is intended for use only by skilled technicians who have the proper tools, equipment, and training to correctly and safely maintain your vehicle. These procedures should not be attempted by "do-it-yourselfers," and you should not assume this bulletin applies to your vehicle, or that your vehicle has the condition described. To determine whether this information applies, contact an authorized Honda automobile dealer.

Intake Manifold Gasket A	17115-5A2-A01	4
Head Cover Gasket Set	12030-5A2-A01	1
Exhaust Pipe Gasket	18212-T2F-A01	1
Chamber Gasket (57.5 mm–58.5 mm)	18393-SS0-J30	1
Primary Converter Gasket	18115-5A2-A01	1
Throttle Body Gasket	17107-R40-A01	1
Flange Nut (8 mm)	94050-08080	2
Self-Lock Nut (10 mm)	90212-SA5-003	6
Oil Jet Kit (comes with two jets and bolts)	04100-5A2-305	1
Oil Seal (43 mm X 58 mm X 7 mm)	91212-5A2-A01	1
Oil Seal Control Valve	15832-RAA-A01	1
O-Ring	91311-5A2-A01	1
O-Ring	91304-5A2-A01	1
O-Ring (12.6 mm X 2.4 mm)	91305-5A2-A01	2
O-Ring (37.2 mm X 4.25 mm)	91314-PR7-A00	2
Oil Pump O-Ring	91303-5A2-A01	2
Water Passage O-Ring (oil)	19412-5A2-A00	1
Water Passage O-Ring (water)	19411-5A2-A00	1
Fuel Joint Pipe Set	16012-5A2-315	1
Thermostat Case Seal	19322-5A2-A00	1
Spark Plug	12290-5A2-A02	4
Drain Plug Washer (14 mm)	94109-14000	1

#### PARTS INFORMATION – SHORT BLOCK

Part Name	Part Number	Quantity
Short Block (if necessary)	10002-5A2-A01	1

#### PARTS INFORMATION – CYLINDER HEAD

Part Name	Part Number	Quantity
Cylinder Head (if necessary)	10003-5A2-A03	1

## PARTS INFORMATION – PISTONS

Part Name	Part Number	Quantity
Piston Set (STD) (A)	13010-5A2-A00	4
Piston Set (STD) (B)	13020-5A2-A00	4
Piston Ring Set (STD)	13011-5A2-A11	4

## REQUIRED MATERIALS

Part Name	Part Number	Quantity
Honda Bond 4 (One tube will repair 5 vehicles.)	08717-1194	1
Genuine Honda Motor Oil (0W-20)	08798-9036	4
Honda Long-Life Antifreeze/Coolant Type 2	OL999-9011	1

## TOOL INFORMATION

Part Name	Tool Number	Quantity
Universal Lifting Eyelet	07AAK-SNAA120	1
Universal Lifting Eyelet	07AAK-SNAA600	1
Load Rotor® Positioning Sling (Load Leveler)	OTC1805 or equivalent	1
Floor Crane	NRI78106A or equivalent	1
Engine Stand	NRI78100 or equivalent	1
Tapered Piston Ring Compressor - 87 mm	SCP1287 or equivalent	1
Ridge Reamer (If needed to remove carbon)	WR30A or equivalent	1

These tools are available through the Honda Tool and Equipment Program at **888-424-6857**. Verify that these tools are on hand before scheduling the repair.

## WARRANTY CLAIM INFORMATION

**NOTE: There is no additional flat rate time for cylinder head replacement since this component is already disassembled.**

The normal warranty applies.

Operation Number	Description	Flat Rate Time	Defect Code	Symptom Code	Template ID	Failed Part Number
1111EC	Do the engine oil consumption test, replace the oil jets, <b>piston set A</b> , and rings.	11.1 hrs	06901	09401	A17089A	10002-5A2-A01
1111EC	Do the engine oil consumption test, replace the oil jets, <b>piston set A</b> , rings, and cylinder head.	11.1 hrs	06901	09401	A17089B	10002-5A2-A01

1111EC	Do the engine oil consumption test, replace the oil jets, <b>piston set B</b> , and rings.	11.1 hrs	06901	09401	A17089C	10002-5A2-A01
1111EC	Do the engine oil consumption test, replace the oil jets, <b>piston set B</b> , rings, and cylinder head.	11.1 hrs	06901	09401	A17089D	10002-5A2-A01

1111ED	Do the engine oil consumption test, replace the short block, and oil jets.	11.5 hrs	06901	09401	A17089E	10002-5A2-A01
1111ED	Do the engine oil consumption test, replace the short block, cylinder head, and oil jets.	11.5 hrs	06901	09401	A17089F	10002-5A2-A01

Skill Level: Repair Technician

## DIAGNOSIS

- Do an engine oil consumption test. Refer to the job aid *Engine Oil Consumption Test*.
- Review the results from the engine oil consumption test.
  - Based on the test results, if the engine is consuming an unusually high amount of oil, contact your DPSM for approval, then go to REPAIR PROCEDURE.
  - Based on the test results, if the engine is consuming a normal amount of engine oil, the vehicle is OK. Have the service advisor explain to the customer that the vehicle is OK and that the consumption of oil is within a normal range.

NOTE: Have the service advisor remind the customer to regularly check the engine oil level every time the fuel tank is filled. Modern engines require less frequent oil changes, which may impact the amount of oil used between oil changes.

## REPAIR PROCEDURE

The following service information procedures are used in full or in part within this service bulletin. For more details on these procedures and torque specifications, refer to the service information.

- Left Front Fender Trim
  - Fuel Pressure Relieving
  - Battery Removal
  - Air Cleaner Assembly Removal
  - Intake Manifold Removal and Installation
  - Engine Oil Replacement
  - Coolant Replacement
  - Drive Belt Removal/Installation
  - Warm-Up TWC Removal/Installation
  - Cam Chain Removal
  - Cylinder Head Removal
  - Valve Adjustment
  - Oil Pan Installation
  - PCM Idle Learn Procedure
1. Open the hood, and set it to the wide-open position.

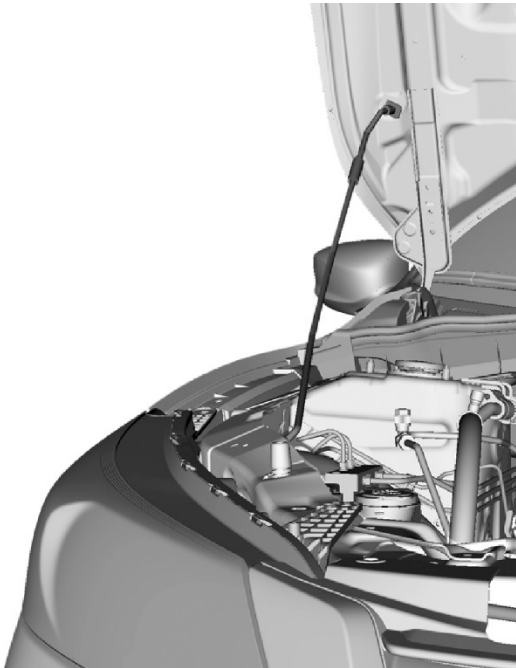

2. Disconnect the 12-volt battery.
3. Raise the vehicle.
4. Remove both front wheels.
5. Drain the engine oil and coolant from the vehicle.
6. Remove the front splash shield.
7. Remove the exhaust pipe A.
8. Remove the transmission inspection cover.
9. Remove the torque converter bolts.
10. Remove the starter.
11. Remove the intake and exhaust manifold brackets.
12. Unbolt the right axle carrier-bearing mount from the short block, roll it towards the firewall, and support it to prevent interference when removing the long block assembly.

13. Remove the AC compressor without disconnecting the lines. Secure it to the lower sub frame below the alternator.
14. Disconnect the engine's wire harness connectors from the engine components, and secure them out of the way.
15. Remove the air intake box.
16. Disconnect and remove the PCM with the bracket.
17. Remove the front tower bar.
18. Relieve the fuel pressure.
19. Disconnect the fuel line.
20. Remove the throttle body.
21. Remove the intake manifold.
22. Remove the warm-up TWC (primary converter).
23. Disconnect all of the thermostat housing hoses.
24. Remove the thermostat housing with the water passage connecting pipe.
25. Support the transmission with a jack and a wooden block to prevent damage to the transmission oil pan.
26. Remove the front, rear, and right side engine mount brackets.
27. Install the universal lifting eyelet on the timing chain side (07AAK-SNAA120). Then, install the universal lifting eyelet on the transmission side with a spacer (07AAK-SNAA600).

NOTE: Make sure the eyelets are tightly secured to the engine block to prevent any unnecessary stress.

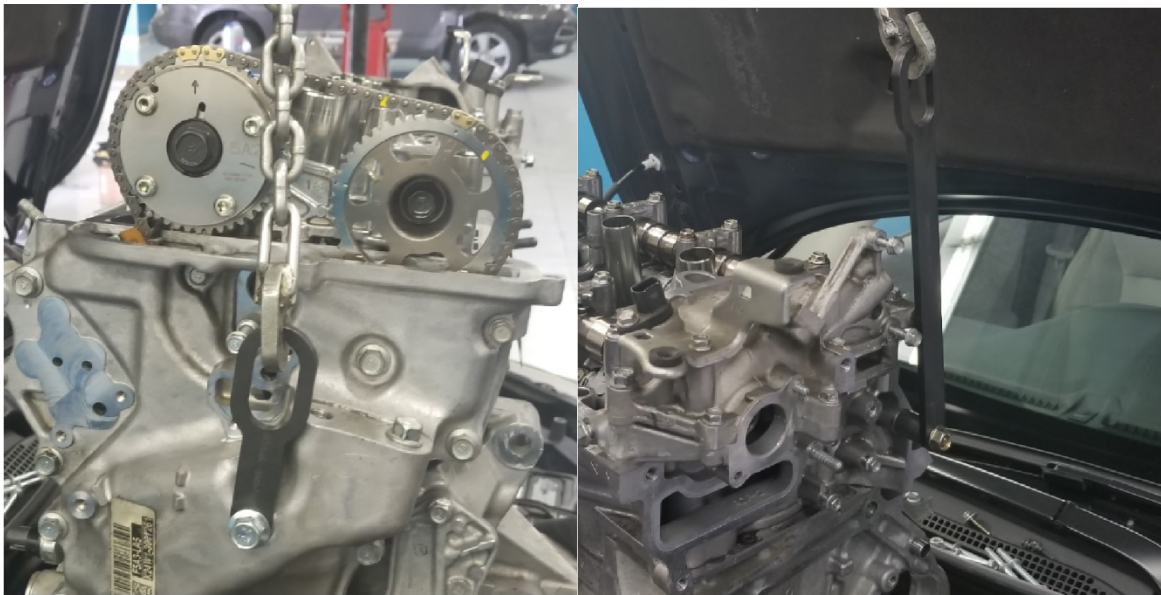

28. Secure the engine with a chain, load leveler, and engine hoist.

NOTE: Using a load leveler helps avoid interference from the chain and valve cover. Also, it will help prevent any unnecessary bracket flex along with helping tilt the engine for easy removal and installation.

29. Remove the long block from the vehicle, and place the engine on an engine stand.

NOTE: Do not use the transmission bolt holes on the section of the oil pan to support the engine.

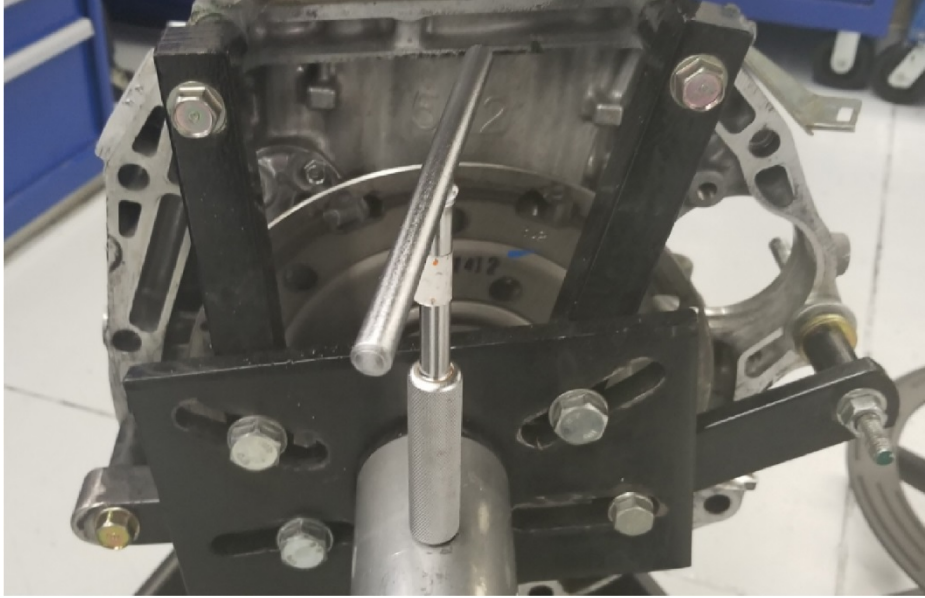

### CYLINDER HEAD REMOVAL AND INSPECTION

1. Remove the high pressure fuel pump.
2. Remove the ignition coils.
3. Remove the valve cover.
4. Remove the front crank pulley.
5. Remove the spool valve assembly.
6. Remove the VTC oil control solenoid valve.
7. Remove the timing chain cover.
8. Remove the timing chain.
9. Remove the cam cover on the high pressure fuel pump base.
10. Remove the intake camshaft sensor.
11. Remove the high pressure fuel pump base.
12. Remove the camshaft bearing caps, and organize them accordingly.
13. Remove the camshafts.

NOTE: Remove the rocker arms and rocker shafts, then remove the camshafts. Use a strip magnet to keep the VTEC rockers from separating. Be sure to wrap the magnet with tape to prevent damaging the rockers and bearing surfaces.



14. Remove the cylinder head bolts. To prevent warpage, loosen them in sequence 1/3 turn at a time. Repeat this sequence until all of the bolts are loosened.

15. Remove the cylinder head, and visually inspect the combustion side of the valves for damage.

NOTE: This is only a visual inspection when looking for damage to the valves.

- If any of the valves show signs of damage, replace the cylinder head and go to CYLINDER BORE INSPECTION.
- If the valves are OK, go to step 16.

16. Visually inspect each spark plug for damage or melted pieces of the center electrode or ground electrode.

- If any of the spark plugs show signs of damage, remove the valve closest to the damaged plug from the cylinder head and go to step 17.
- If the spark plugs are OK, go to CYLINDER BORE INSPECTION.

17. Visually inspect the cylinder head valve seat and the valve seat face for damage.

- If there are any signs of physical damage, replace the cylinder head and go to CYLINDER BORE INSPECTION.
- If the valves and valves seats are OK, reassemble the cylinder head and go to CYLINDER BORE INSPECTION.

### CYLINDER BORE INSPECTION

Check the cylinder walls by lightly rubbing your fingernail or a pencil perpendicular to any vertical scratches that are on the cylinder bore.

- If your fingernail or a pencil does not catch on the scratches, the cylinder block is OK. Go to OIL PAN REMOVAL.
- If your fingernail or pencil catches on the scratches, contact your DPSM for short block replacement approval. Refer to the service information to replace the short block.

NOTE: If the short block is replaced, you will still need to replace the oil jets. Countermeasure oil jets have not been installed at the factory.



Normal honing marks shown.



Light scratches are not abnormal. Ensure a fingernail or pencil "catches" on the scratches before replacing the block.



## OIL PAN REMOVAL

1. Remove the oil pan.
2. Secure the chain tensioner with a pin, and remove the oil pump tensioner.
3. Place a punch in the alignment hole in the pump, and remove the oil pump gear and chain.

NOTE: To hold the front balancer shaft to remove the drive gear, insert a 6 mm long pin punch (Snap-on PPC108LA or equivalent) into the maintenance hole in the balancer shaft holder and through the front balancer shaft.

6 mm LONG PIN PUNCH

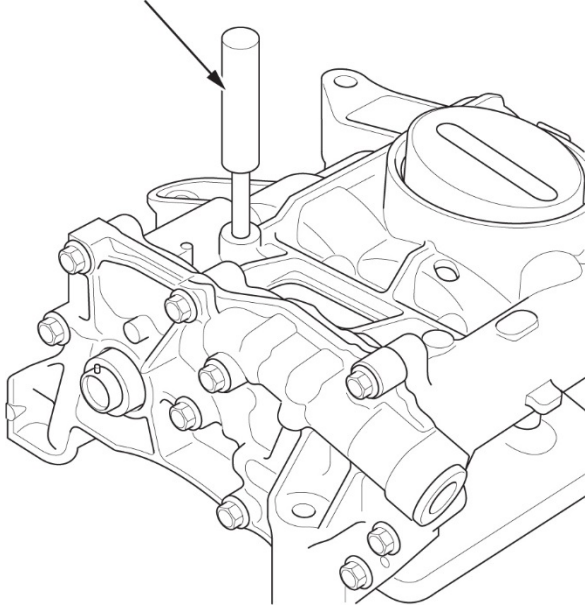

4. Remove the oil pump.
5. Remove the baffle plate.

## REMOVAL OF PISTONS AND RODS

NOTE: Before removing pistons, rods, and caps, mark each piston top with the cylinder number and directional mark to indicate the front of the engine.

1. Prepare your workbench with a number location for each piston rod assembly to ensure the rods and caps are not mixed, as they are not interchangeable. The numbers stamped across the side of the rod and cap do not indicate the cylinders they came from; they are a manufacturing number.

NOTE:

- Before removing the rod caps, use a grease pencil or suitable marking pen to mark each cap and its corresponding connecting rod with the cylinder number it came from. This ensures you're putting the same rod and cap back together with the right orientation.

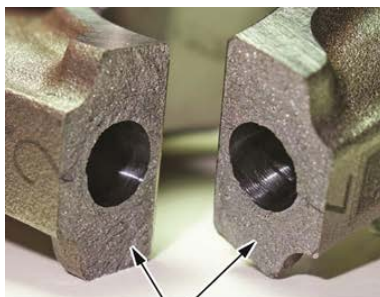

The uneven mating surfaces are uniquely matched and not interchangeable.

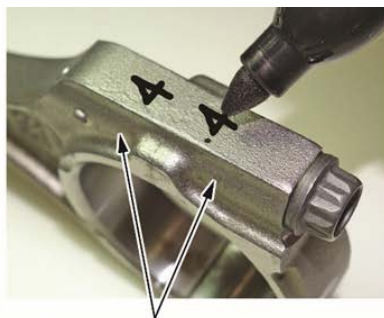

Mark the connecting rod and rod cap with the cylinder number.



These are manufacturing marks, and do not indicate the cylinder number.

- Don't confuse the existing markings on the side of the connecting rod and rod cap with a cylinder number. They're just manufacturing marks referring to the size of the big end of the rod.
- When torquing the rod cap bolts, refer to the service information for details.

If you would like to see a video on this subject, we've added one to *Tech2Tech®*. Look for "Tips When Working With Fracture Rods."

2. Install the crank pulley and the key on the crank without the bolt.
3. Using a wooden or plastic-handled hammer, gently push the pistons and rod assemblies out of the short block.

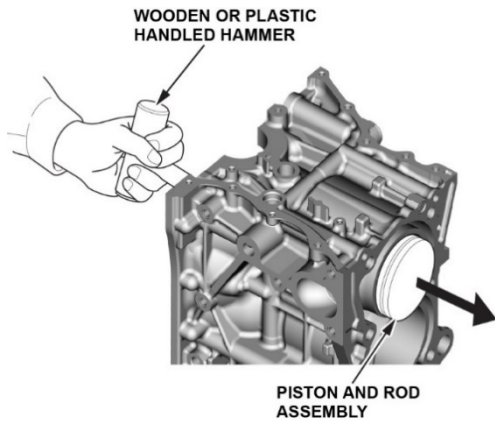

4. Visually inspect all connecting rod bearings for signs of damage.

NOTE: If your fingernail catches on a scratch or groove in the bearing, replace it. Pictured are normal, reusable rod bearings after about 35,000 miles. Some discoloration is normal and does not require replacement.



5. Reassemble the rod caps on the corresponding rods.

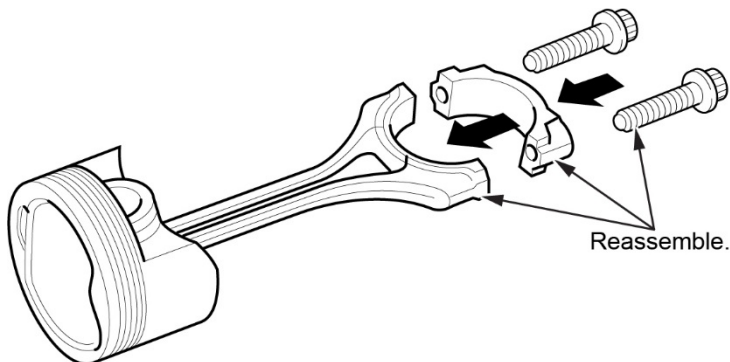

6. Replace all the pistons.

## ASSEMBLY OF NEW RINGS ON NEW PISTONS

NOTE: When ordering pistons, the old pistons will have a letter A or B on the top and on the block.

1. Install the rings as shown. You will see RC stamped on the top ring and 2R on the second ring. The manufacturing marks must face upward.

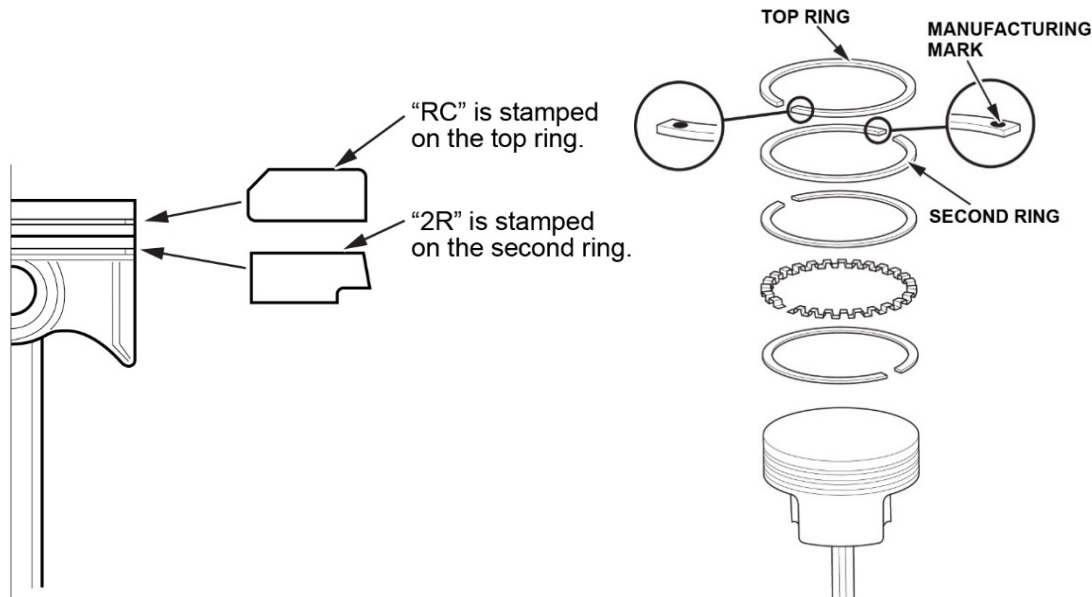

2. Rotate the rings in their grooves to make sure they do not bind.
3. Position the ring end gaps as shown.

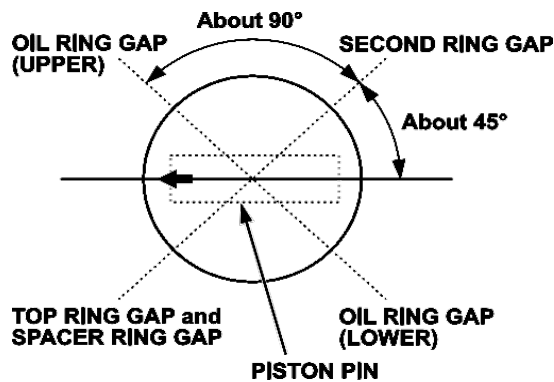

4. Repeat steps 1 thru 3 on the remaining three piston assemblies.

## PISTON INSTALLATION

Note: If carbon buildup is severe enough, a ridge reamer (WR30A or equivalent) may be necessary to remove the carbon off the top of the cylinder. Failure to remove this can damage the new piston rings upon installation and cause damage to the cylinder.

1. Rotate the crankshaft so the cylinder No. 1 and 4 journals are at bottom dead center (BDC).
2. Remove the connecting rod cap from piston No. 1, and check that the bearing is secure.
3. Apply new engine oil to the entire piston, the inside of the ring compressor, the cylinder bore, and the rod bearings.

4. Position the embossed mark on the rod to face the cam chain end of the engine block.

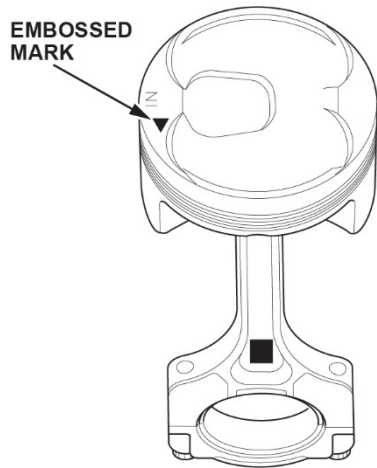

5. Set the piston in the ring compressor and position it in the cylinder, noting the rod/cap marks that you made in step 3 of REMOVAL OF PISTONS AND RODS.

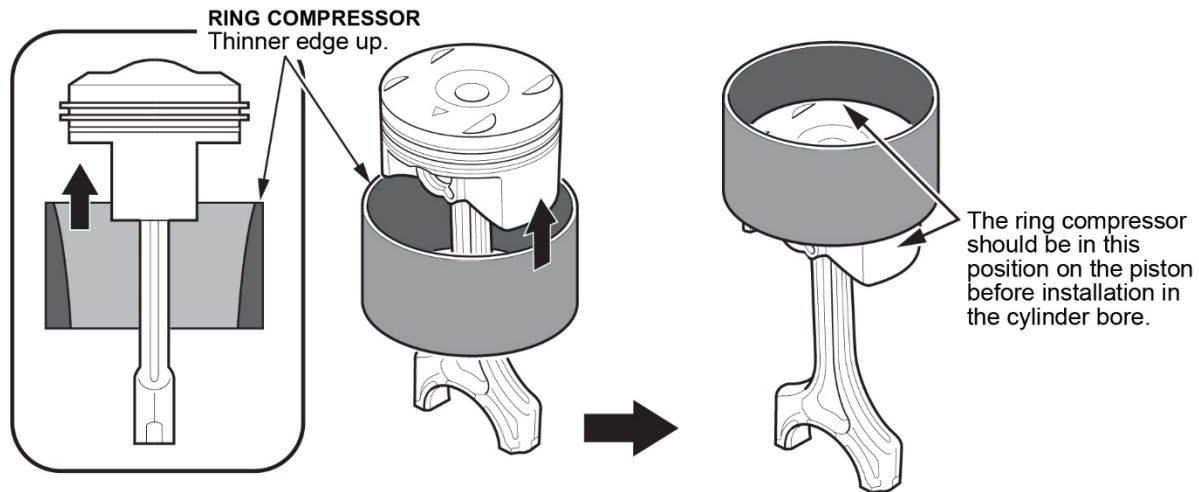

6. Set the ring compressor on the cylinder bore, then push the piston in with your hands.

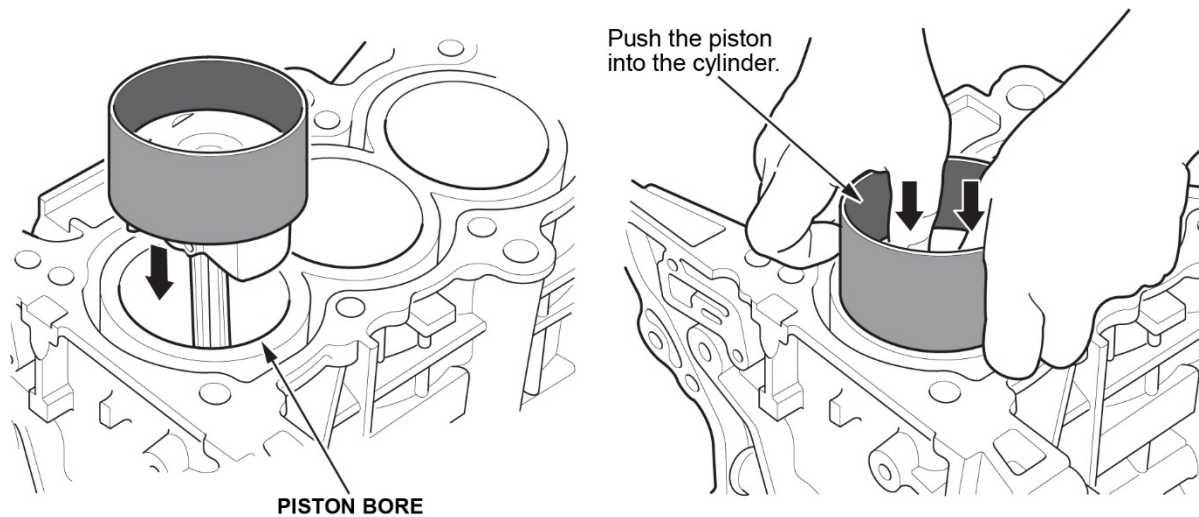

7. Stop after the ring compressor pops free, and check the connecting rod-to-rod journal alignment before pushing the piston into place.

8. Measure the diameter of each connecting rod bolt at point A and point B with a micrometer.

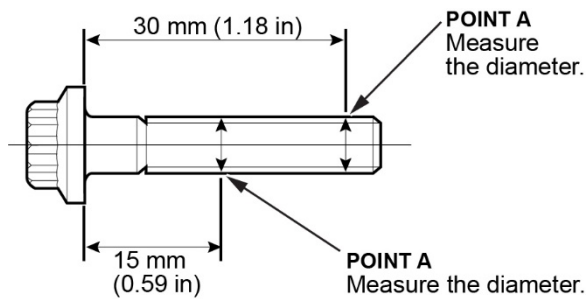

9. Calculate the difference in diameter between point A and point B.

**Point A – Point B = Difference in diameter**  
**Difference in Diameter Specification: 0 – 0.1 mm (0 – 0.004 in)**

10. If the difference in diameter is out of tolerance, replace the affected connecting rod bolt.  
11. Apply new engine oil to the bolt threads, and then install the rod caps with the bearings.  
12. Torque the bolts to **5 N·m (4 lb-ft)**.  
13. Torque the bolts to **40.7 N·m (30 lb-ft)**.  
14. Tighten the connecting rod bolts an additional 90 degrees.

NOTE: Remove the connecting rod bolt if you tightened it beyond the specified angle, and repeat step 12 and 13 of the procedure. Do not loosen it back to the specified angle.

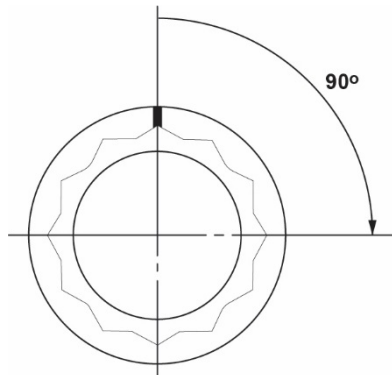

15. Repeat steps 2 thru 14 to install piston No. 4.  
16. Rotate the crankshaft 180 degrees, and repeat steps 2 thru 13 to install pistons No. 2 and No. 3.

## OIL JET VALVE REPLACEMENT

1. Remove the oil jet bolts, and replace with the new bolts.
2. Install the baffle plate.

Required tools:

- Ratchet handle
- Extension
- Wobble socket
- Torque wrench

NOTE: Ensuring alignment of the oil jet pin is critical to proper function.

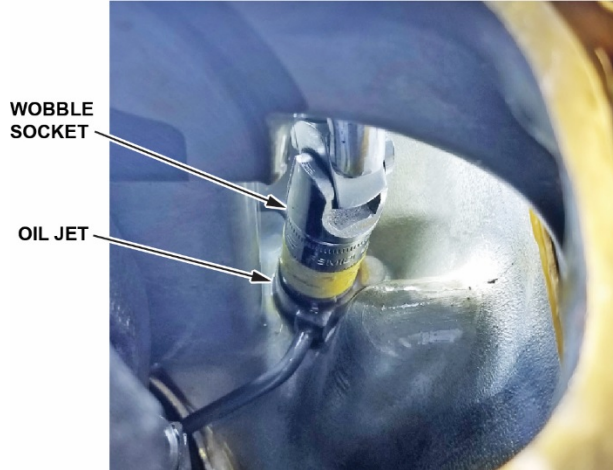

Here is an example of an improperly placed oil jet. You can see the index hole is not filled by the nozzle alignment pin.

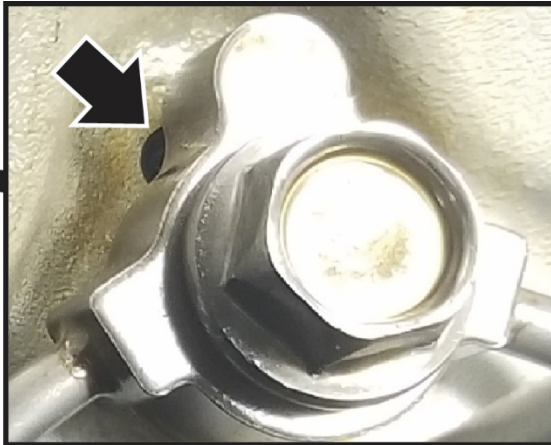
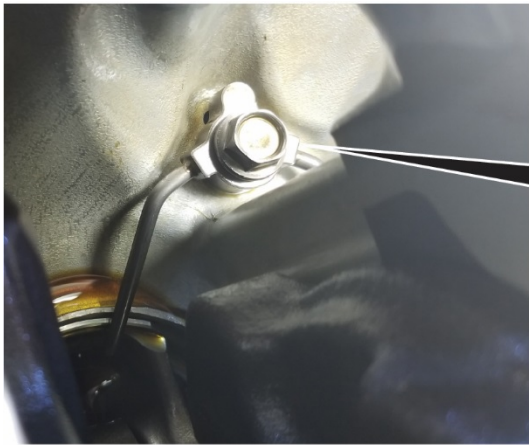

ALIGNMENT  
PIN HOLE



ALIGNMENT  
PIN

## OIL PUMP INSTALLATION

3. Align the dowel pin on the rear balancer shaft with the mark on the oil pump.

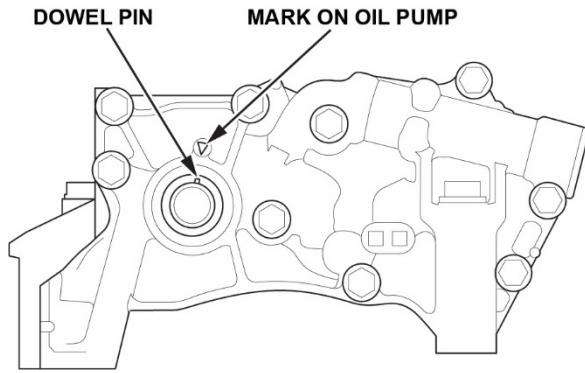

4. To hold the front balancer shaft, insert a 6 mm long pin shaft (Snap-on PPC108LA or equivalent) into the maintenance hole in the balancer shaft holder and through the front balancer shaft.

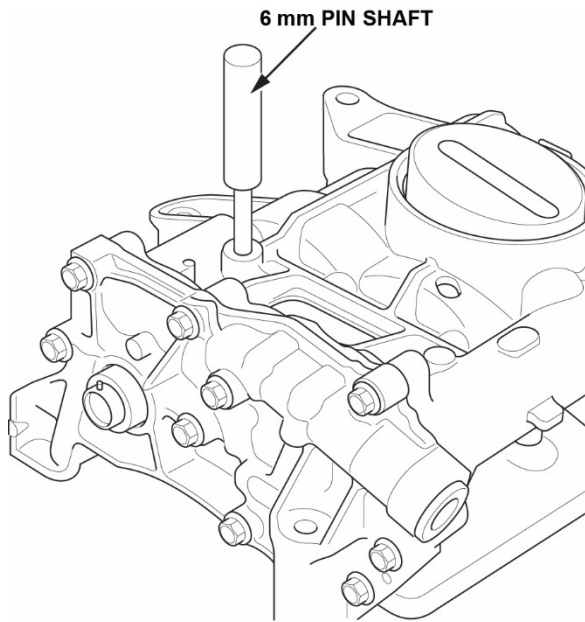

5. Apply new engine oil to the threads of the oil pump mounting bolts, then loosely install the oil pump with a new O-ring.

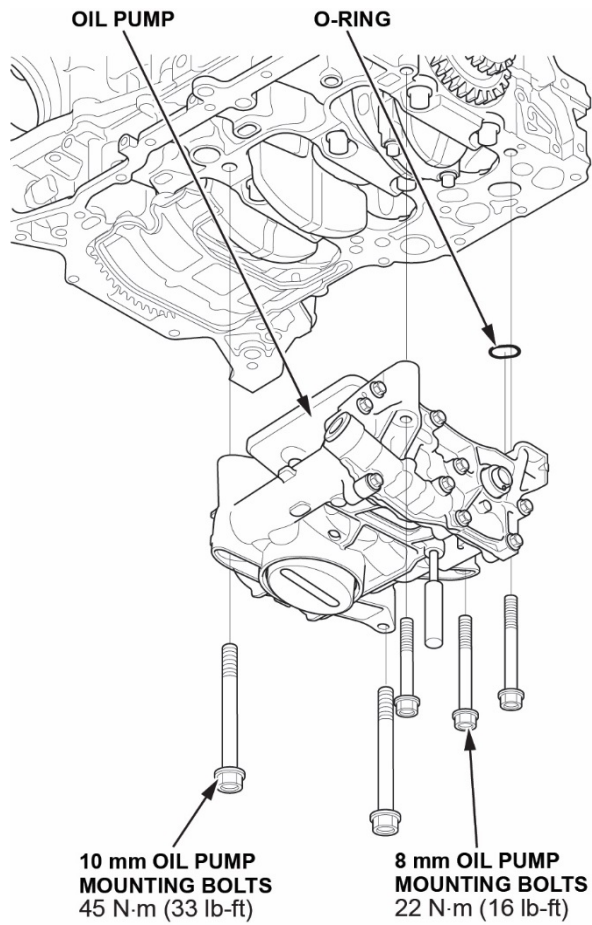

6. Tighten the oil pump mounting bolts.



7. Set the crankshaft to top dead center (TDC). Align the TDC mark on the crankshaft sprocket with the pointer on the engine block.

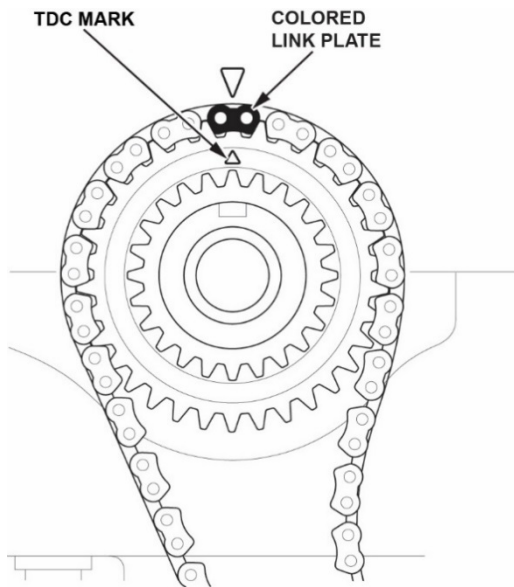

8. Set the oil pump chain on the oil pump chain sprocket with the punch mark aligned with the center of the colored link plate.

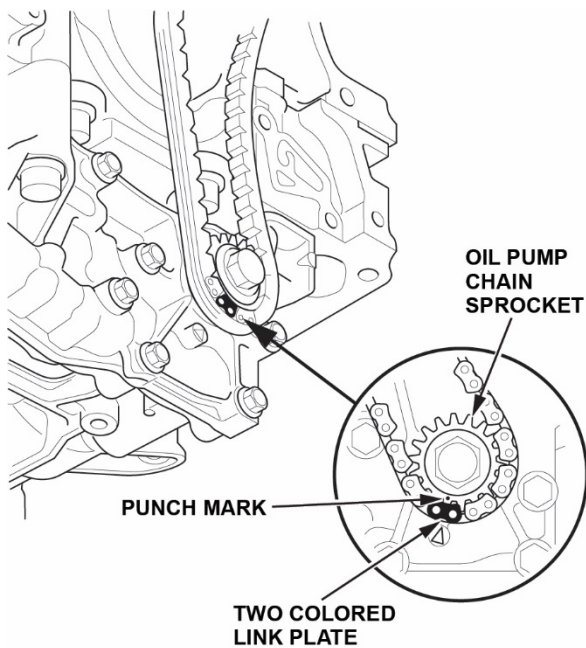

9. Turn the plate counterclockwise to release the lock. Then push the oil pump chain arm, and set the first cam to the first edge of the rack. Insert a 2.0 mm (5/64 in) diameter pin into the hole.

NOTE: If the oil pump chain auto-tensioner is not set up as described, the oil pump chain auto-tensioner can be damaged.

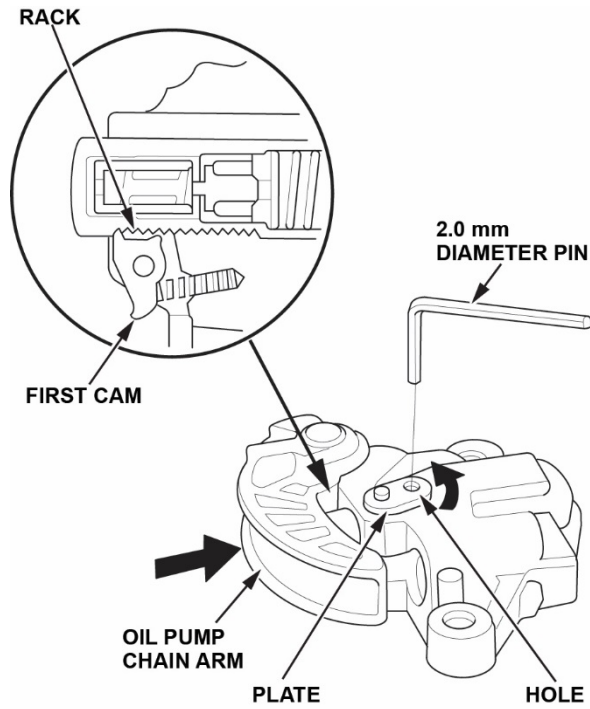

10. Install the oil pump chain auto-tensioner.

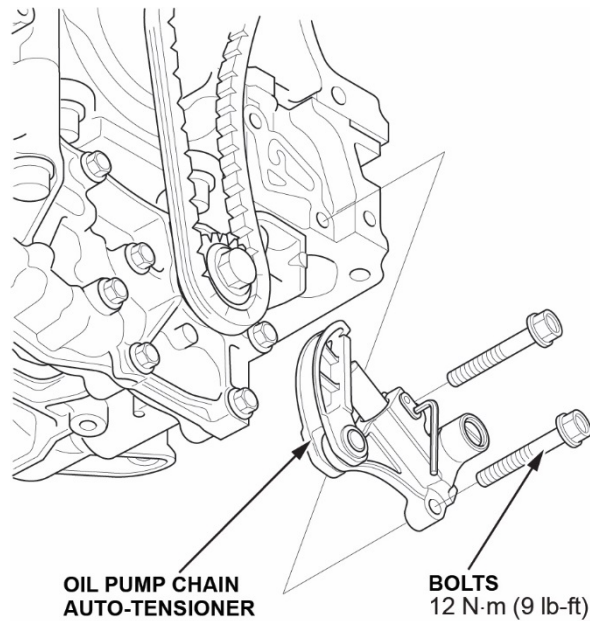

11. Remove the pin from the oil pump chain auto-tensioner.

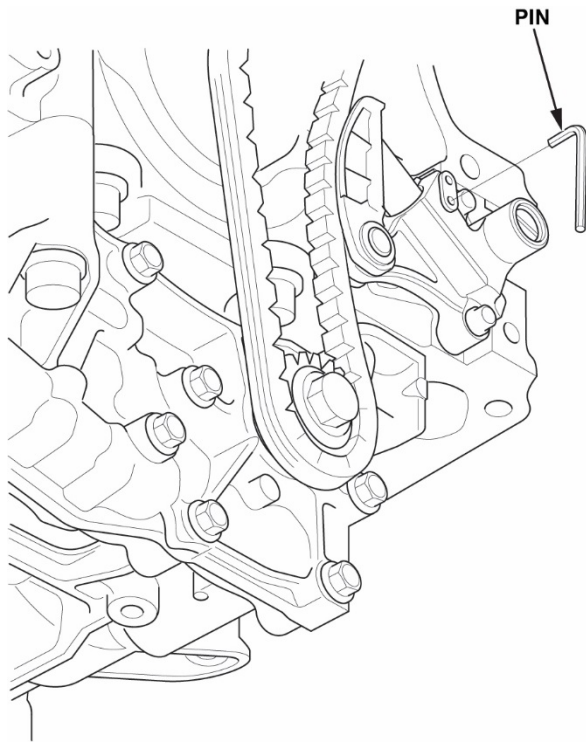

## OIL PAN INSTALLATION

1. Remove all of the old liquid gasket from the oil pan mating surfaces, the bolts, and the bolt holes.

Clean and dry the oil pan mating surfaces and the O-ring groove. Apply liquid gasket, (P/N 08718-0003, 08718-0004 or 08718-0009) to the engine block mating surface of the oil pan and to the inside edge of the threaded bolt holes. Install the component within 5 minutes of applying the liquid gasket.

### NOTE:

- Apply a 2.5 mm (0.098 in)-diameter bead of liquid gasket along the broken line as indicated.
- If too much time has passed after applying the liquid gasket, remove the old liquid gasket and residue, and reapply new liquid gasket.

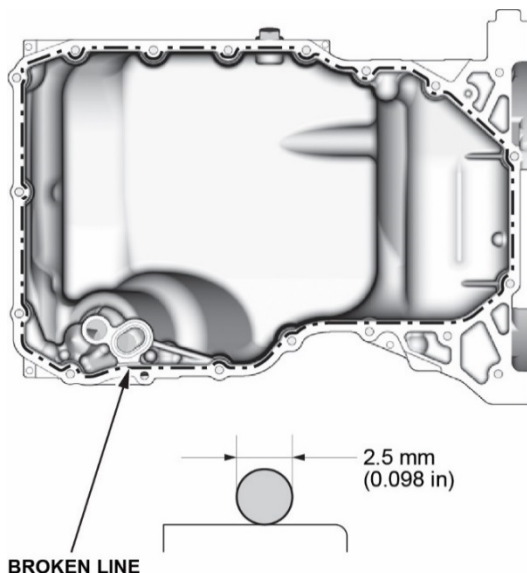

2. Install the oil pan with a new O-ring.

NOTE:

- Raise the oil pan carefully to avoid damaging the IMA motor rotor position sensor.
- Wait at least 30 minutes before filling the engine with oil.
- Do not run the engine for at least 3 hours after installing the oil pan.
- Make sure to install the bolts in the correct locations according to size.

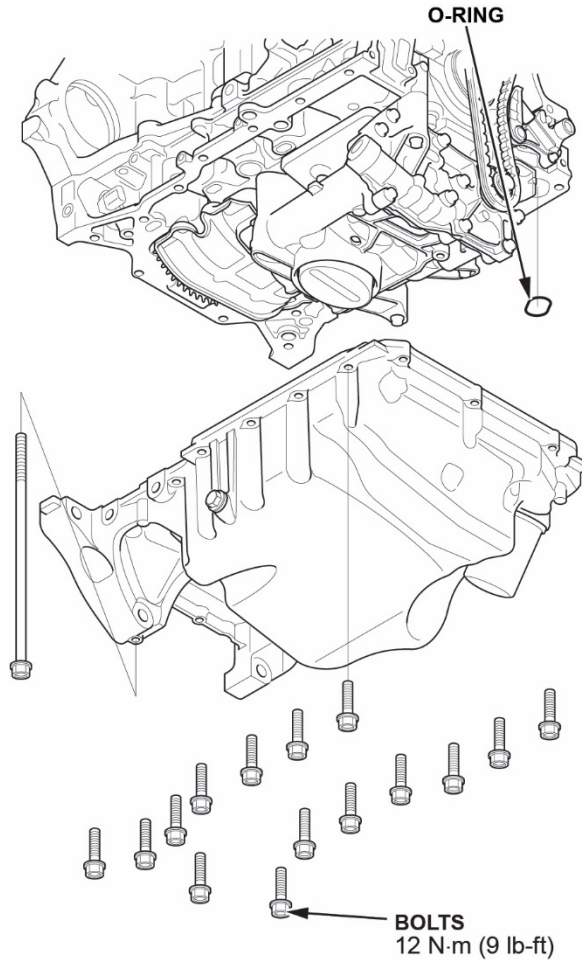

3. Tighten the bolts in three steps. In the final step, torque all bolts, in sequence, to **12 N·m (9 lbf-ft)**. Wipe off the excess liquid gasket on the each side of crankshaft pulley and flywheel/drive plate.

NOTE:

- Wait at least 30 minutes before filling the engine with oil.
- Do not run the engine within 3 hours after installing the oil pan.

4. Install a new cylinder head gasket and the dowel pins on the engine block. Always use a new cylinder head gasket.

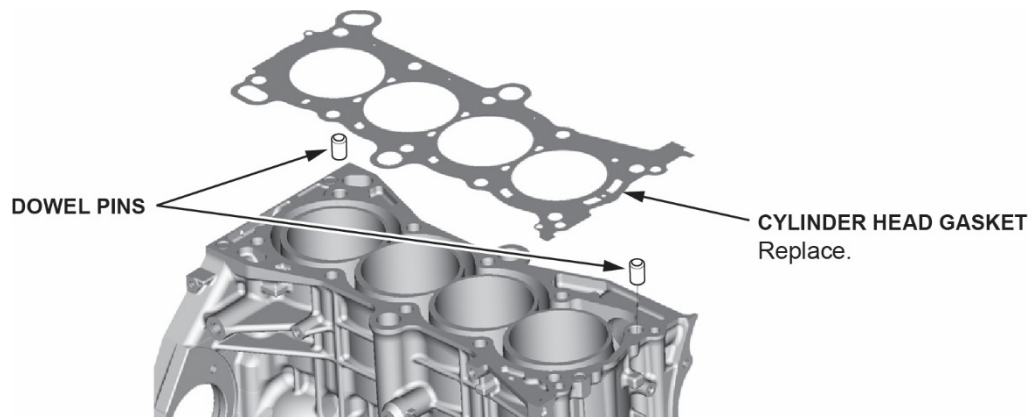

5. Set the crankshaft to top dead center. Align the TDC mark on the crankshaft sprocket with the pointer on the engine block.

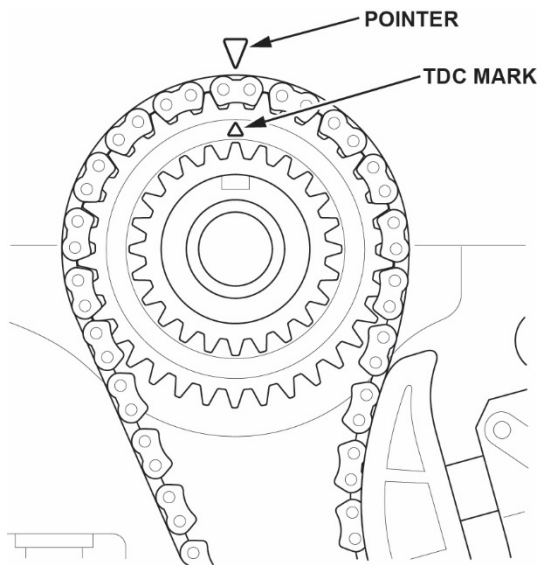

6. Install the cylinder head on the engine block.

7. Measure the diameter of each cylinder head bolt at point A and point B.

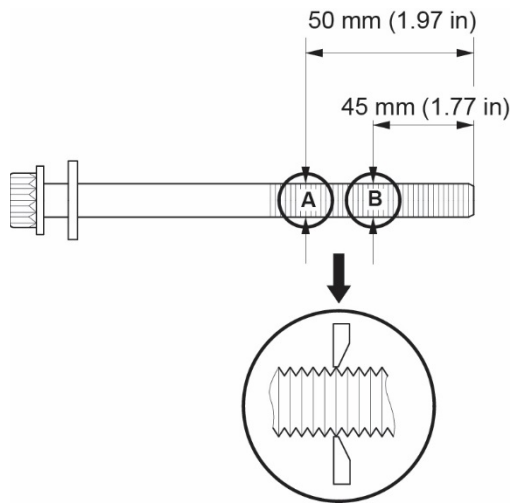

8. If either diameter is less than 10.6 mm (0.417 in), replace the cylinder head bolt.
9. Apply new engine oil to the threads and under the bolt heads of all cylinder head bolts.
10. Torque the cylinder head bolts in sequence to **40 N·m (30 lb-ft)**. Use a beam-type torque wrench. When using a preset click-type torque wrench, be sure to tighten slowly and do not overtighten. If a bolt makes any noise while you are torquing it, loosen the bolt and retighten it from the first step.

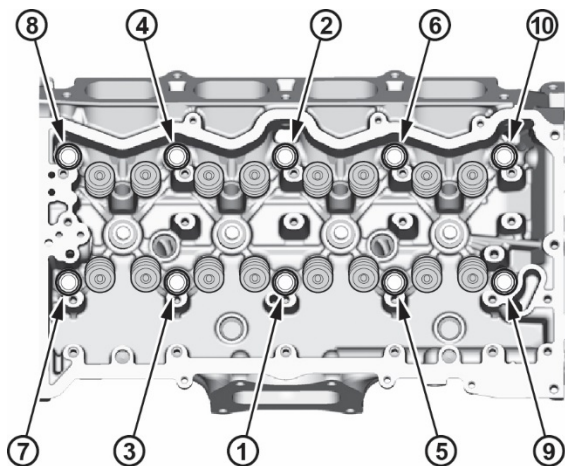

11. After torquing, tighten all cylinder head bolts in two steps (90 degrees per step) using the sequence shown in step 10. If you are using a new cylinder head bolt, tighten the bolt an extra 90 degrees.

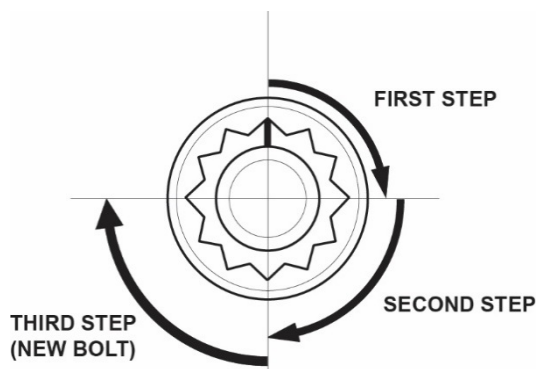

NOTE: Remove the cylinder head bolt if you tightened it beyond the specified angle, and go back to step 6 of the procedure. Do not loosen it back to the specified angle.

12. Install the rocker arm assembly.

13. Install the cam chain.
14. Adjust the valve clearance.
15. Install the thermostat housing.
16. Install the cylinder head cover.
17. Install the high pressure pump.
18. Install all remaining parts according to the service information.

END