

This Field Service Bulletin replaces bulletin "Flywheel Resurfacing Guidelines", (USA139701533) PV729-FSB216-002_V, dated 10/2017.

Flywheel Resurfacing Guidelines
VN, VHD, VAH, VT

FSB 216-002, Flywheel Resurfacing Guidelines

(February 2018)

This document is intended to give guidelines for resurfacing the flywheel in certain VOLVO VN, VHD, VAH, and VT trucks equipped with an I-Shift Automated Manual Transmission (AMT). Follow the guidelines outlined in this Field Service Bulletin (FSB) to ensure the proper flywheel resurfacing requirements are met.

You must read and understand the precautions and guidelines in Service Information, group 20, "General Safety Practices, Engine" before performing this procedure. If you are not properly trained and certified in this procedure, ask your supervisor for training before you perform it.

NOTE: Information is subject to change without notice. Illustrations are used for reference only and can differ slightly from the actual vehicle being serviced. However, key components addressed in this information are represented as accurately as possible.

Service personnel: Please circulate, read and initial

Service Manager	Warranty Administrator	Workshop Foreman	Service Technicians						

Fly Wheel Resurfacing Guidelines

Cosmetic Flywheel Wear

- 1 A typical example of flywheel wear is minor blueing, which is a marking that does not affect the operation of the flywheel or clutch friction surfaces. This marking may be seen as a uniform stripe around the complete friction area of the flywheel with occasional larger spots. Flywheel wear is not detectable with the bare hand and may only show very slight wear when measured with a dial indicator. The factory machining marks may be easily visible. Flywheels with cosmetic wear may be reused without resurfacing.



W2128451



W2128452

As shown in the above images, witness marks are present from the clutch operation but there is no wear and the machining marks can still be seen. This condition does not affect the function of the flywheel.



W2128453

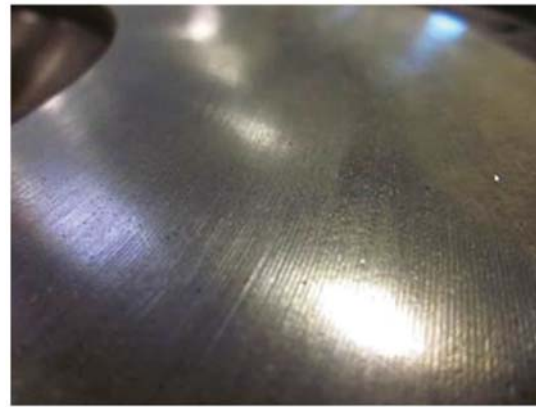

W2128454

Witness marks with light localized minor discoloration of the surface is shown in the above image. No wear is felt on the flywheel surface.

Very well defined manufacturing marks and no wear marks seen on this flywheel. This condition does not affect the function of the flywheel.

Minor Flywheel Wear

- 2 Flywheel surface wear may be perceived with the bare hand and is detected as a change in texture on the wear surface of the flywheel due to surface polishing. Flywheels with this particular type of surface wear may be reused without resurfacing or may be resurfaced if needed. Flywheels with localized blue spots that do not show large cracking can be resurfaced as well.



W2128455

Heavier witness marks and light wear may be noted. This flywheel may still be used without resurfacing.



W2128456

Wider bands of discoloration and some polishing of the surface is shown. Wear may be felt to the touch. However, the discoloration is normal, and will not cause a problem if this flywheel is not resurfaced.



W2128457

Heavier wear and discoloration (Localized Hot Spots) is shown on this flywheel. Check for faults associated with an improper driving style or overload. Resurface the flywheel to clean up the face and reuse this flywheel.



W2128458

Same as the picture at left but with the addition of the light heat checking. This flywheel will require resurfacing. Check for clutch control faults that may cause control issues. Additionally, driver behavior may cause this type of heat checking.

Physical Flywheel Damage

- 1 Physical flywheel damage caused by failure of the clutch or disk is typically seen as chips or dents in the inner dished area of the flywheel and is usually caused by a spring or piece of the disk coming loose. This type of damage does not require replacement of the flywheel and will not affect the operation of the clutch. To repair the flywheel, remove any loose material from the flywheel, clean up the face of the flywheel, de-burr the damaged area, and resurface the flywheel.



W2128470



W2128471

Major Flywheel Damage

- 2 Extreme blueing may destroy the clutch disk, turn the pressure plate and/or the flywheel blue. By touch, it may not feel like there is any wear of the flywheel surface. Even with a dial indicator there may not be very much surface wear measured or indicated. Extreme blueing and heat checking is also accompanied by radial cracks from the clutch mounting holes of the flywheel clutch surface. This condition may be found on the engine side of the flywheel. In extreme cases the engine side of the flywheel will indicate a blue tint if extreme blueing is present. If there is engine side blueing present on the flywheel surface, major surface cracks or radial cracks, as pictured in the following images, the flywheel must be replaced.

Flywheels that get this hot are also accompanied by a completely destroyed clutch. Look for excessive clutch control faults that may indicate the clutch control system is not functioning properly. Operation of the clutch past its useful life could cause the type of flywheel damage shown in the images below and on page 6.



W2128459



W2128460



W2128461



W2128462



W2128464

W2128463



W2128465



W2128469

The ruler shown in these photos are for size reference and not an indication of limits of cracking. Cracks in the flywheel this big will not grind out. Even if they are not seen after grinding, they may still be present.



W2128467



W2128468



W2128466

Flywheel Measurement

Use the procedure below to measure the flywheel:

(A) Select a straight edge that will span the friction surface of the flywheel. Measure the distance from the crankshaft mating side of the flywheel to the straight edge. The minimum thickness must not be less than 57.7 mm (2.27 in).

(B) Do not grind more than needed off of the flywheel. The typical requirement needed is to freshen the surface of the flywheel.

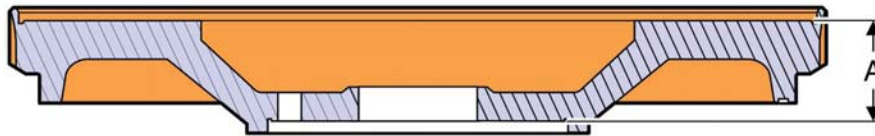

W2128472

AMT Flywheel Dimension "A"	
Flywheel Dimension New	Flywheel Dimension (Minimum Surface Thickness)
59 ± 0.2 mm	57.7 mm (2.271 in)

(C) The radius around the outer diameter of the friction surface may be used as a rough reference of how much life remains in the flywheel. This groove is not a controlled depth and is for manufacturing purposes only. To be certain of the amount of life that remains in the flywheel, the flywheel should be measured as noted above if there is any uncertainty.

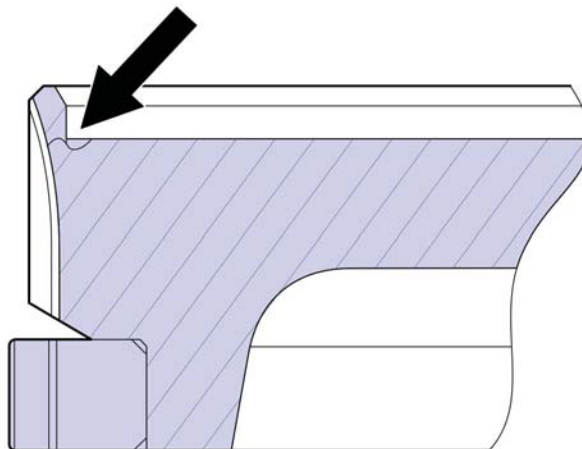

W2128473

(D) Do not grind the outer flange of the flywheel. This flange will not interfere with the mounting of the clutch to the flywheel so this does not need to have the same amount of material removed like some other types of flywheels do.

(E) The flange inner diameter is critical to the location of the clutch cover plate. Care must be taken to not to machine this surface.

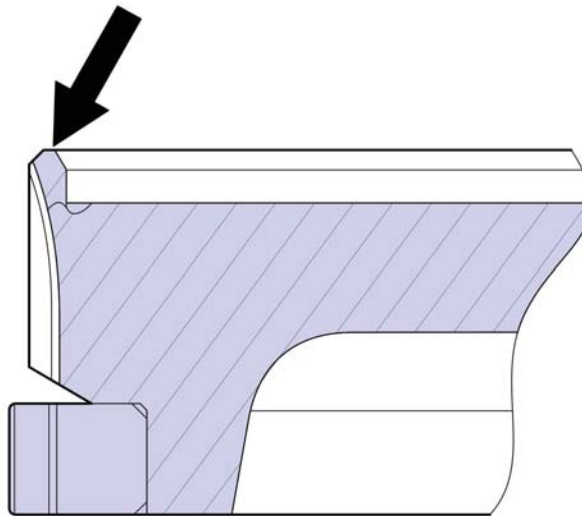

W2128474