

Maintenance for EV & Auxiliary Batteries

Service Category General

Section Pre-Delivery Service

Market USA

Toyota Supports
 ASE Certification 

Applicability

| YEAR(S) | MODEL(S) | ADDITIONAL INFORMATION |
|-------------|----------|------------------------|
| 2013 – 2014 | RAV4 EV | |

REVISION NOTICE

September 6, 2013 Rev1:

- Applicability has been updated to include 2014 model year RAV4 EV vehicles.

Any previous printed versions of this bulletin should be discarded.

Introduction

The RAV4 EV is equipped with 2 types of batteries:

- Electric Vehicle (EV) Traction Battery
- 12-volt Auxiliary Battery

If the RAV4 EV is put into storage, the state of charge (SOC) of the EV battery and auxiliary battery will gradually decrease. To prevent the auxiliary battery from becoming discharged during storage, proper maintenance is necessary.

Please perform the following maintenance service for the EV battery and 12-volt auxiliary battery.

NOTE

- Before disconnecting the auxiliary battery, confirm the shift lever is in the “P” position and apply the parking brake completely. The shift lever CANNOT be shifted from the “P” position with the 12-volt auxiliary battery disconnected.
- When the negative (–) terminal of the auxiliary battery is reconnected, the EV system may not operate if the vehicle is already in “Ready On” state. If this occurs, push the Start/Stop switch to re-initiate the “Ready On” mode. The “Ready” light should illuminate on the Instrument Panel. If the EV system will not “Ready On” refer to the Repair Manual for diagnosis.

Warranty Information

| OP CODE | DESCRIPTION | TIME | OFF | T1 | T2 |
|---------|----------------------------|------|-----|----|----|
| N/A | Not Applicable to Warranty | – | – | – | – |

Maintenance for EV & Auxiliary Batteries

Maintenance Items

| CONDITION* | MAINTENANCE OPERATION |
|---------------------------------------|---|
| Before Delivery | Fully charge 12-volt auxiliary battery (deliver the vehicle to the customer after it is fully charged 12.6 V or more). |
| To Store for 30 Days or More | Disconnect the negative (-) terminal of the 12-volt auxiliary battery under the hood to prevent the SOC of the auxiliary battery from decreasing during storage due to parasitic current. |
| Just After Unloading & Every 2 Months | Fully charge EV battery using vehicle charging station. |

* The condition also corresponds with the section titles within this bulletin.

Required Tools & Equipment

| SPECIAL SERVICE TOOLS (SST) | PART NUMBER | QTY |
|----------------------------------|-----------------------------|-----|
| GR8 Battery Diagnostic Station** | 00002-MCGR8 | 1 |

** Essential SST.

NOTE

The GR8 Battery Diagnostic Station (P/N 00002-MCGR8) supersedes the Automatic Trickle Charger (P/N 00002-YA122-01) and Fast Battery Chargers (Associated P/N ASE6003 and Christie P/N CAPPDQ). P/N 00002-YA122-01, ASE6003, and CAPPDQ are now obsolete.

Before Delivery

Fully charge the 12-volt auxiliary battery:

1. Before charging the auxiliary battery, turn OFF vehicle, lights, and accessories.
2. Open the hood.

Maintenance for EV & Auxiliary Batteries

Before Delivery

Fully charge the 12-volt auxiliary battery: (Continued)

3. Remove the positive (+) terminal cover.

Figure 1.

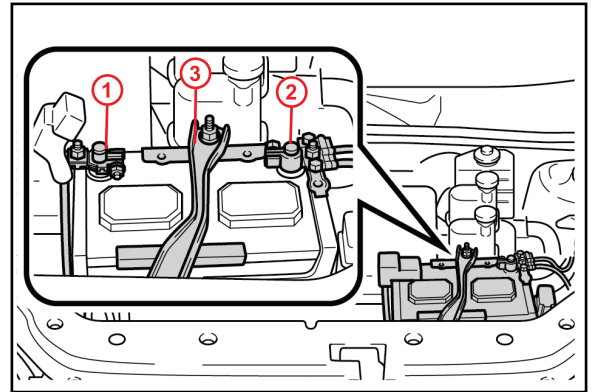

| | |
|----------|----------------------------------|
| 1 | Positive Battery Terminal |
| 2 | Negative Battery Terminal |
| 3 | Hold Down Clamp |

4. Check the battery SOC.
 - If the battery voltage is LESS THAN 12.6 V, then continue to step 5.
 - If the battery voltage is 12.6 V or MORE, replace the positive (+) terminal cover and close the hood.

NOTE

If measuring the voltage with the negative (-) terminal connected, turn vehicle OFF and turn ON the headlights for 20 to 30 seconds. This will remove the surface charge from the battery.

Maintenance for EV & Auxiliary Batteries

Before Delivery

Fully charge the 12-volt auxiliary battery: (Continued)

5. Test/charge the 12-volt auxiliary battery using the GR8 Battery Diagnostic Station.
 - A. Connect the red charger clamp to the positive (+) battery terminal and the black charger clamp to the negative (-) battery terminal.
 - B. Plug the charger into a grounded 110-volt nominal outlet and flip the power switch to the "ON" position.
 - C. Once the charger is properly turned ON, perform a diagnostic charge.

The GR8 Battery Diagnostic Station will indicate result when complete.

If the battery tests bad ("Replace Battery"), then replace the auxiliary battery.

NOTE

If the auxiliary battery was stored at 32°F (0°C) or below, charge the auxiliary battery in a room above 32°F (0°C).

CAUTION

- Charge in a well-ventilated area.
- Do NOT allow sparks or fire near the auxiliary battery.

If the GR8 Battery Diagnostic Station is NOT available, you may charge the 12-volt battery by cycling the vehicle on to "READY."

- Run time will vary depending on the state of charge.
- If this method is used, you must confirm that the battery is charged to 12.8 volts using a DVOM.

Figure 2.

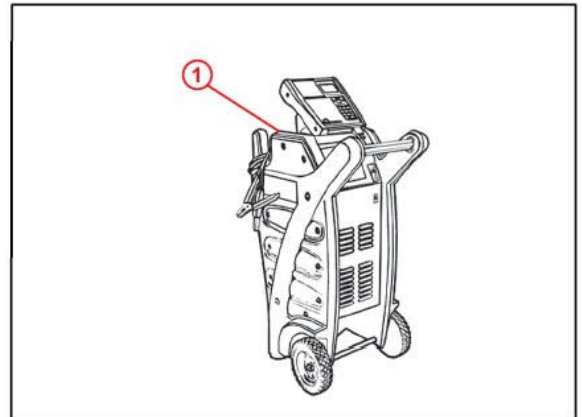

| | |
|----------|------------------------|
| 1 | P/N 00002-MCGR8 |
|----------|------------------------|

Maintenance for EV & Auxiliary Batteries

Before Delivery

Fully charge the 12-volt auxiliary battery: (Continued)

6. After charging the auxiliary battery, install the positive (+) terminal cover.

Figure 3.

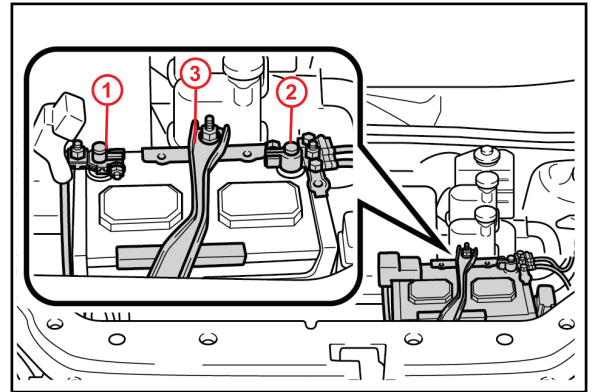

| | |
|----------|----------------------------------|
| 1 | Positive Battery Terminal |
| 2 | Negative Battery Terminal |
| 3 | Hold Down Clamp |

7. Close the hood.

To Store for 30 Days or More

Disconnect the negative (-) terminal:

1. Turn OFF vehicle, lights, and accessories.
2. Open the hood.

Maintenance for EV & Auxiliary Batteries

To Store for 30 Days or More

Disconnect the negative (-) terminal: (Continued)

3. Disconnect the negative (-) terminal.

Figure 4.

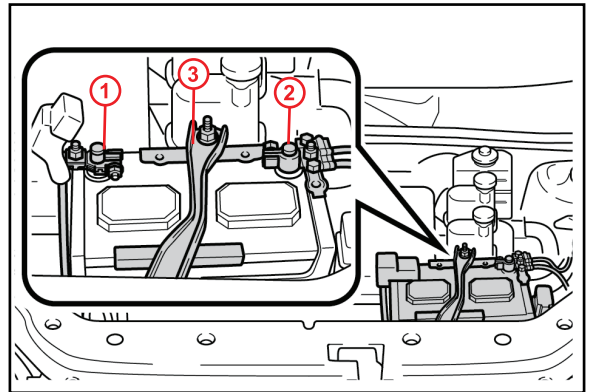

| | |
|----------|---------------------------|
| 1 | Positive Battery Terminal |
| 2 | Negative Battery Terminal |
| 3 | Hold Down Clamp |

4. Close the hood.

NOTE

When it is necessary to move the vehicle, reconnect the negative (-) terminal.

Maintenance for EV & Auxiliary Batteries

To Store for 30 Days or More (Continued)

When removing the vehicle from storage, connect the negative (-) terminal:

1. Open the hood.
2. Connect the negative (-) terminal.
Torque: 6.0 N*m (61 kgf*cm, 4.4 ft*lbf)

Figure 5.

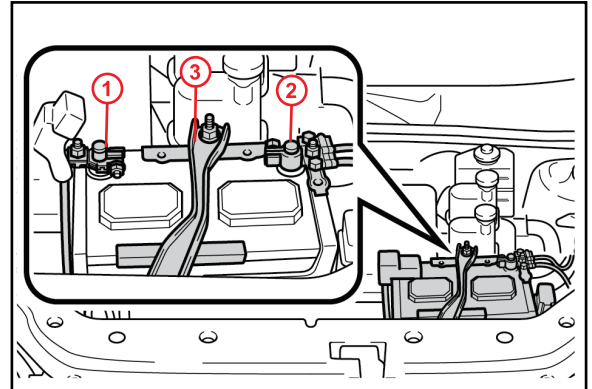

| | |
|----------|----------------------------------|
| 1 | Positive Battery Terminal |
| 2 | Negative Battery Terminal |
| 3 | Hold Down Clamp |

3. Close the hood.

NOTE

When the negative (-) terminal of the auxiliary battery is reconnected, the EV system may not operate if the vehicle is already in "Ready On" state. If this occurs, push the Start/Stop switch to re-initiate the "Ready On" mode. The "Ready" light should illuminate on the Instrument Panel. If the EV system will not "Ready On" refer to the Repair Manual for diagnosis.

Maintenance for EV & Auxiliary Batteries

Every Two Months

NOTE

Be sure to reconnect the negative (-) terminal of the auxiliary battery **BEFORE** performing this procedure.

1. Park the vehicle next to the EV Charging Station.
2. Apply the parking brake.
3. Turn OFF vehicle, lights, and accessories.
4. Check that the shift lever is in the “P” position.
5. Connect the charging station plug to the vehicle. Confirm that both lights above the charge plug illuminate. Fully charge the EV battery.

Figure 6.

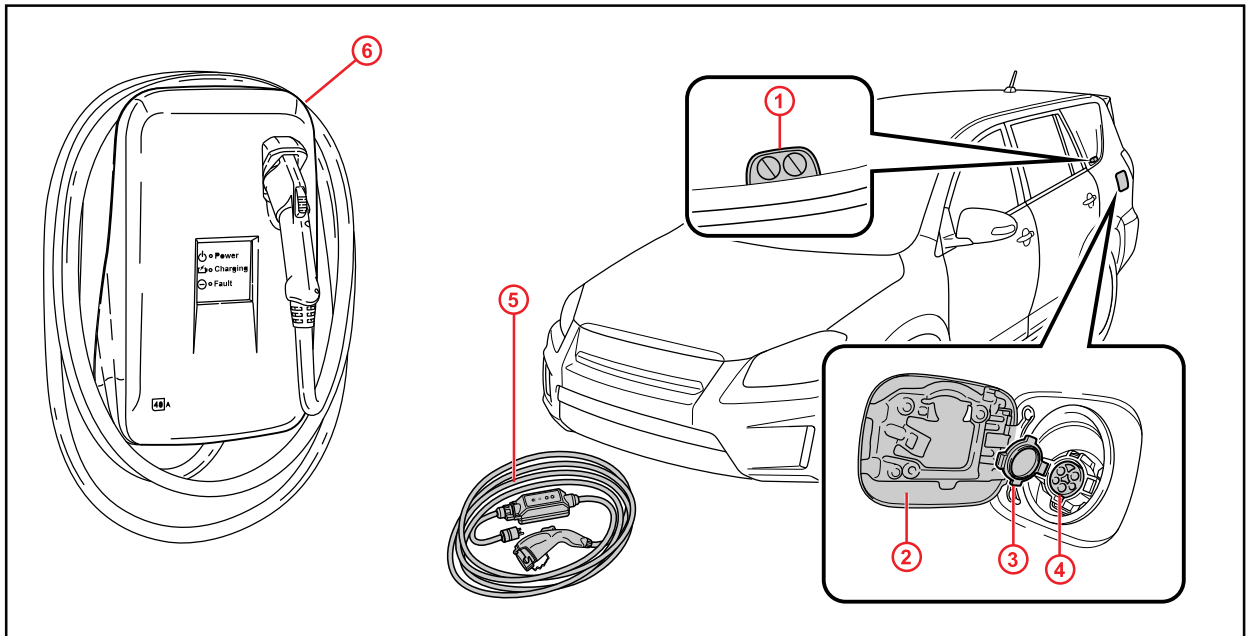

| | |
|----------|--------------------|
| 1 | Charging Indicator |
| 2 | Charging Port Door |
| 3 | Charging Port Cap |

| | |
|----------|-------------------------------------|
| 4 | Charging Port |
| 5 | Charging Cable with CCID (in trunk) |
| 6 | EV Charging Station |

Maintenance for EV & Auxiliary Batteries

Every Two Months (Continued)

Figure 7.

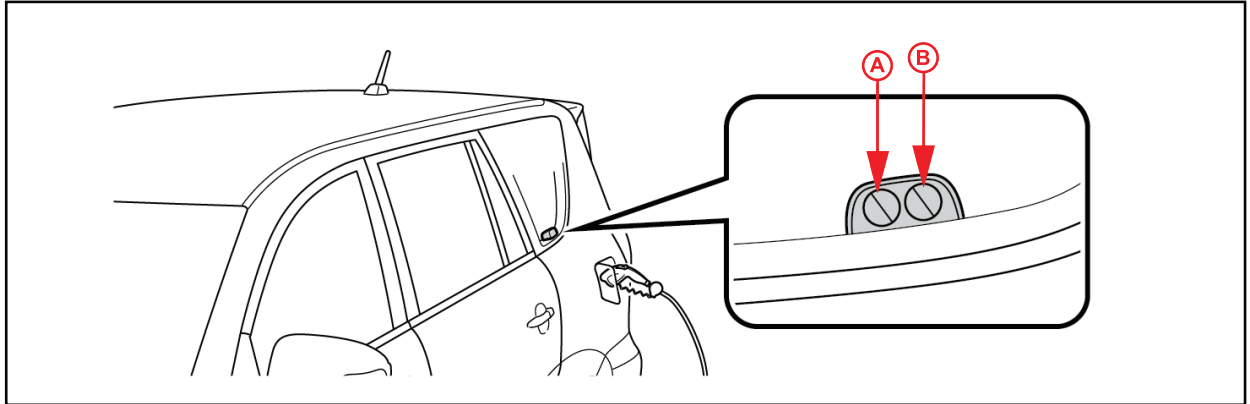

A Light A

B Light B

Check the status of the charging indicator. The charging indicator consists of 2 lights that display charging status by illuminating, flashing, and turning off as follows.

| CHARGING STATUS | CHARGING INDICATOR | |
|--|---|---------|
| | LIGHT A | LIGHT B |
| The charging cable is connected to the vehicle and the charging and/or pre-climate schedule is set | Lights A and B flash On and Off alternately for 10 minutes. (After 10 minutes both lights remain Off until charging starts) | |
| Charge level is less than 49% | Flashes | Off |
| Charge level is between 50% and less than 99% | Illuminates | Flashes |
| Charging is complete | Both lights A and B illuminate for 10 minutes. (After 10 minutes both lights turn Off) | |
| Malfunction occurred during charging | Both lights A and B quickly flash simultaneously for 10 seconds. (After 10 seconds both lights turn Off) | |

The indicator lights will not flash or turn on when the charging cable is not connected properly.