



# 2014 PRE-DELIVERY SERVICE CHECK SHEET

November 2013

BEFORE INSPECTION	OK	Adjust/Repair
01 Install Short Pin (see page 2) .....	<input type="checkbox"/>	
FUNCTIONAL OPERATION		
<i>Apply parking brake and cycle ignition "IG-ON"; place gear selector in reverse; turn on lights and rear defogger. Unlock doors; release fuel door.</i>		
01 Check dome, courtesy, map, and sun visor lights* .....	<input type="checkbox"/>	<input type="checkbox"/>
02 Check warning/indicator lights, gauges, and horn .....	<input type="checkbox"/>	<input type="checkbox"/>
03 Check windshield wipers and washers .....	<input type="checkbox"/>	<input type="checkbox"/>
04 Check headlights, instrument lights, turn signals, dimmer switch, emergency flashers, and brake lights .....	<input type="checkbox"/>	<input type="checkbox"/>
05 Check inside/outside rear view mirror operation/adjustment .....	<input type="checkbox"/>	<input type="checkbox"/>
06 Check cigarette lighter* and power outlets* .....	<input type="checkbox"/>	<input type="checkbox"/>
07 Check audio/navigation* systems, set SSP to xB, and set clock .....	<input type="checkbox"/>	<input type="checkbox"/>
08 Install shift-lock override button cover .....	<input type="checkbox"/>	
09 Check Rear Seat Entertainment System operation* .....	<input type="checkbox"/>	
WALKAROUND INSPECTION		
<i>Start at left front door. Check window and door lock operation (from master power switch, if equipped). Continue around vehicle in a counterclockwise direction checking each door and window operation, child door locks, seat belts, interior condition, all lights, luggage compartment contents. Finish by checking headlight aim and continue into UNDER HOOD checks.</i>		
01 Check power window operation .....	<input type="checkbox"/>	<input type="checkbox"/>
02 Check door and door lock operation, including each wireless remote control/theft deterrent system* .....	<input type="checkbox"/>	<input type="checkbox"/>
03 Check that engine starts with all keys .....	<input type="checkbox"/>	<input type="checkbox"/>
04 Check that child safety door locks are in normal (unlocked) position* .....	<input type="checkbox"/>	<input type="checkbox"/>
05 Check seats and seat belt operation .....	<input type="checkbox"/>	<input type="checkbox"/>
06 Check rear defogger/rear view mirror defogger* .....	<input type="checkbox"/>	<input type="checkbox"/>
07 Check side marker, tail, backup, and license plate lights. ....	<input type="checkbox"/>	<input type="checkbox"/>
08 Check luggage compartment light* & trim appearance ...	<input type="checkbox"/>	<input type="checkbox"/>
09 Adjust spare tire pressure, inspect for defects/damage, and check jack and tool installation .....	<input type="checkbox"/>	<input type="checkbox"/>
10 Check headlight aim .....	<input type="checkbox"/>	<input type="checkbox"/>
UNDER HOOD		
01 Check engine oil and ATM* fluid levels .....	<input type="checkbox"/>	<input type="checkbox"/>
02 Check brake and clutch* levels .....	<input type="checkbox"/>	<input type="checkbox"/>
03 Check engine coolant level .....	<input type="checkbox"/>	<input type="checkbox"/>
04 Check windshield washer fluid level .....	<input type="checkbox"/>	<input type="checkbox"/>
05 Check battery state-of-charge using Digital Battery System Analyzer (SOC Reading: _____%) .....	<input type="checkbox"/>	<input type="checkbox"/>
06 Inspect for fuel, oil, coolant, and other fluid leaks .....	<input type="checkbox"/>	<input type="checkbox"/>
* Inspect or install when equipped/required.		

UNDER VEHICLE (ON HOIST)	OK	Adjust/Repair
01 Remove disc brake anti-corrosion wheel film* .....	<input type="checkbox"/>	
02 Inspect tires for defects/damage .....	<input type="checkbox"/>	<input type="checkbox"/>
03 Activate Tire Pressure Warning System (TPWS) (see page 2) .....	<input type="checkbox"/>	
04 Install wheel covers/caps/spare tire wheel covers* .....	<input type="checkbox"/>	<input type="checkbox"/>
05 Inspect for fuel, oil, coolant, and other fluid leaks .....	<input type="checkbox"/>	<input type="checkbox"/>
06 Visually check bolts and nuts on chassis and powertrain for looseness .....	<input type="checkbox"/>	<input type="checkbox"/>
07 Inspect under the vehicle for damage, rust, etc. ....	<input type="checkbox"/>	<input type="checkbox"/>
08 Install rubber body plugs (stored in glove box or center center console) .....	<input type="checkbox"/>	<input type="checkbox"/>
ROAD TEST		
<i>A complete road test helps assure customer satisfaction. Drive vehicle over a variety of road surfaces and driving conditions. Check for unusual noise and driving performance.</i>		
<b>Enter Odometer Reading</b>		
Reading Before Test: _____ Reading After Test: _____		
01 Check cold engine operation .....	<input type="checkbox"/>	<input type="checkbox"/>
02 Check engine operation during warm-up .....	<input type="checkbox"/>	<input type="checkbox"/>
03 Check engine at normal operating temperature .....	<input type="checkbox"/>	<input type="checkbox"/>
04 Check clutch or transmission operation .....	<input type="checkbox"/>	<input type="checkbox"/>
05 Check brake and parking brake operation .....	<input type="checkbox"/>	<input type="checkbox"/>
06 Check steering operation and off-center/vehicle pull/flutter .....	<input type="checkbox"/>	<input type="checkbox"/>
07 Inspect for abnormal noise and vibration .....	<input type="checkbox"/>	<input type="checkbox"/>
08 Inspect for squeaks and rattles .....	<input type="checkbox"/>	<input type="checkbox"/>
09 Check front and rear* heater and A/C operation .....	<input type="checkbox"/>	<input type="checkbox"/>
10 Check speedometer operation .....	<input type="checkbox"/>	<input type="checkbox"/>
11 Check cruise control operation* .....	<input type="checkbox"/>	<input type="checkbox"/>
FINAL INSPECTION AND CLEANING		
01 Remove interior protective covers, unnecessary labels, tags, etc. (Remove just before delivery to customer) .....	<input type="checkbox"/>	
02 Verify floor mat application and install using retaining clips* .....	<input type="checkbox"/>	<input type="checkbox"/>
03 Visually inspect all interior parts for installation, damage, fit, dirt, etc. ....	<input type="checkbox"/>	<input type="checkbox"/>
04 Remove Rapgard™ and clear protective bumper film* ....	<input type="checkbox"/>	
05 Wash and clean vehicle .....	<input type="checkbox"/>	
06 Inspect paint finish for scratches, chips, rust, dents, damage, etc. ....	<input type="checkbox"/>	<input type="checkbox"/>
07 Inspect exterior body parts for proper installation, damage, rust, etc. ....	<input type="checkbox"/>	<input type="checkbox"/>
08 Place oil change sticker on inside of windshield, top left corner .....	<input type="checkbox"/>	
09 Place Owner's Guide and first aid kit portfolio* in glove box .....	<input type="checkbox"/>	
10 Install front license plate and mounting bracket* (see page 2) .....	<input type="checkbox"/>	
11 Perform Techstream Health Check .....	<input type="checkbox"/>	<input type="checkbox"/>

Completion and retention of this form is required to comply with Toyota's Warranty Policy.

TECHNICIAN'S SIGNATURE \_\_\_\_\_

SERVICE MANAGER'S SIGNATURE \_\_\_\_\_

NAME (PLEASE PRINT) \_\_\_\_\_

NAME (PLEASE PRINT) \_\_\_\_\_

Date

Dealer Name

Dealer Code

Vehicle Identification Number (Sticker)

**We hereby certify that all items on this form have been checked and corrected for proper operation as required.**

## SHORT PIN INSTALLATION

To minimize battery discharge the Short Pin has been removed and is stored in the engine compartment Relay Block. Install the Short Pin and confirm all related DTCs are cleared.

### DTC Clearing Procedure

1. Connect Techstream.
2. Cycle the ignition switch to the "IG-ON" position.
3. Using Techstream, check any other codes being output.
4. Erase DTCs (B1650 & B1794) and Freeze Frame Data.

#### NOTE

If any DTCs besides B1650 & B1794 appear, repair the applicable system according to the Repair Manual.

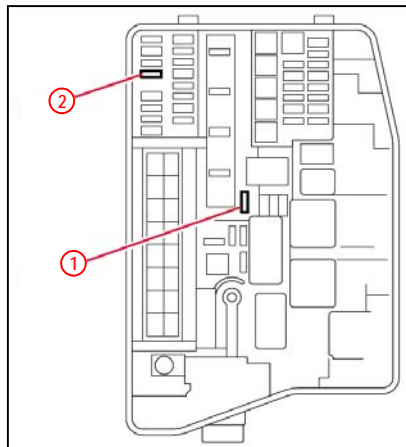

- 1 Remove This Short Pin
- 2 Install Short Pin Here

## TPWS ACTIVATION & INITIALIZATION

### Activation Procedure

1. Connect Techstream.
2. Cycle the ignition switch to the "IG-ON" position and check that the Low Tire Pressure Warning Light blinks for 1 minute and then remains illuminated.
3. Press or remove the valve core to reduce the tire inflation pressure rapidly by 6 psi (0.4 kgf/cm<sup>2</sup>, 40 kPa), or more, within 30 seconds.
4. Check that the Low Tire Pressure Warning Light goes OFF after all the TPWS sensors are activated.

#### NOTE

To adjust the tire pressure correctly when the outside temperature is significantly colder than shop temperature, perform a Health Check using Techstream and select the "Compensation Tire Pressure" checkbox. Compensation pressures will be displayed on the Health Check results screen. Adjust the tire pressure when the tires are cold.

5. Using Techstream, check for DTCs (C2111-C2114). If no DTCs are stored, continue to Initialization procedure. If these DTCs are stored, repeat step 3.

### Initialization Procedure

Refer to the Repair Manual for the [Initialization procedure](#). Please note the spare tire does not have a TPWS sensor.

## FRONT LICENSE PLATE & MOUNTING BRACKET INSTALLATION\*

For states that require a front license plate, please install per this procedure. The bracket and self-tapping screws are stored in the luggage compartment.

### Installation Procedure

1. Insert the front license plate into the mounting bracket
2. Attach the hooks of the mounting bracket to the upper lip of the air intake and rotate the bracket upwards and hold in place.

#### NOTE

The mounting bracket should snap securely onto the bumper cover.

4. Align the installation holes on the mounting bracket and front license plate with the dimples on the front bumper.
5. Screw in the 2 self-tapping screws directly into the dimples to install the front license plate and mounting bracket.

#### NOTICE

- Do NOT pre-drill holes into the bumper.
- Do NOT overtighten the self-tapping screws.

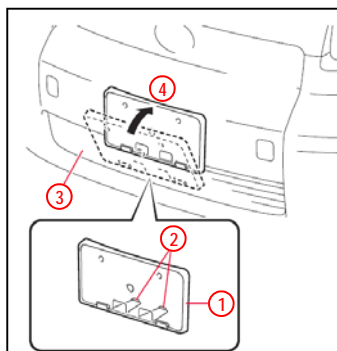

- 1 Mounting Bracket
- 2 Hooks
- 3 Air Intake
- 4 Rotate Bracket

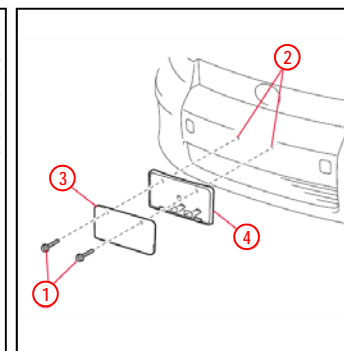

- 1 Self-tapping Screws
- 2 Dimples
- 3 License Plate
- 4 Mounting Bracket