

# Smart Key System Check During PDS

Service  
Category General

Section Pre-Delivery Service

Market USA

Toyota Supports  
ASE Certification 

## Applicability

YEAR(S)	MODEL(S)	ADDITIONAL INFORMATION
2014	4Runner, Avalon, Avalon HV, Camry, Camry HV, Highlander, Highlander HV, Land Cruiser, Prius, Prius C, Prius PHV, Prius V, RAV4, Sequoia, Sienna, Venza	

### REVISION NOTICE

April 23, 2013 Rev1:

- The Inspection Procedure has been updated.

Any previous printed versions of this bulletin should be discarded.

## Introduction

Some 2014 model year vehicles are equipped with a Smart Key system, which allows the customer to enter and start the vehicle without using a mechanical key. To ensure the system is operating properly, the Smart Key functions (Smart Entry and Smart Start) should be inspected during Pre-Delivery Service (PDS). The following inspection procedure has been developed to confirm the proper operation of the Smart Key system prior to vehicle delivery.

### NOTE

Check ALL of the Smart Keys using this procedure.

## Warranty Information

OP CODE	DESCRIPTION	TIME	OFFP	T1	T2
N/A	Not Applicable to Warranty	-	-	-	-

## Smart Key System Check During PDS

### Inspection Procedure

1. Remove ALL Smart Keys from the vehicle.

**NOTE**  
The remaining keys need to be a minimum of 3 feet (1 meter) away from the vehicle.

2. Check Smart Entry function at all the doors.

**NOTE**  
Smart Key MUST be in actuation area No. 1 for this check (see Figure 1 below).

Figure 1.

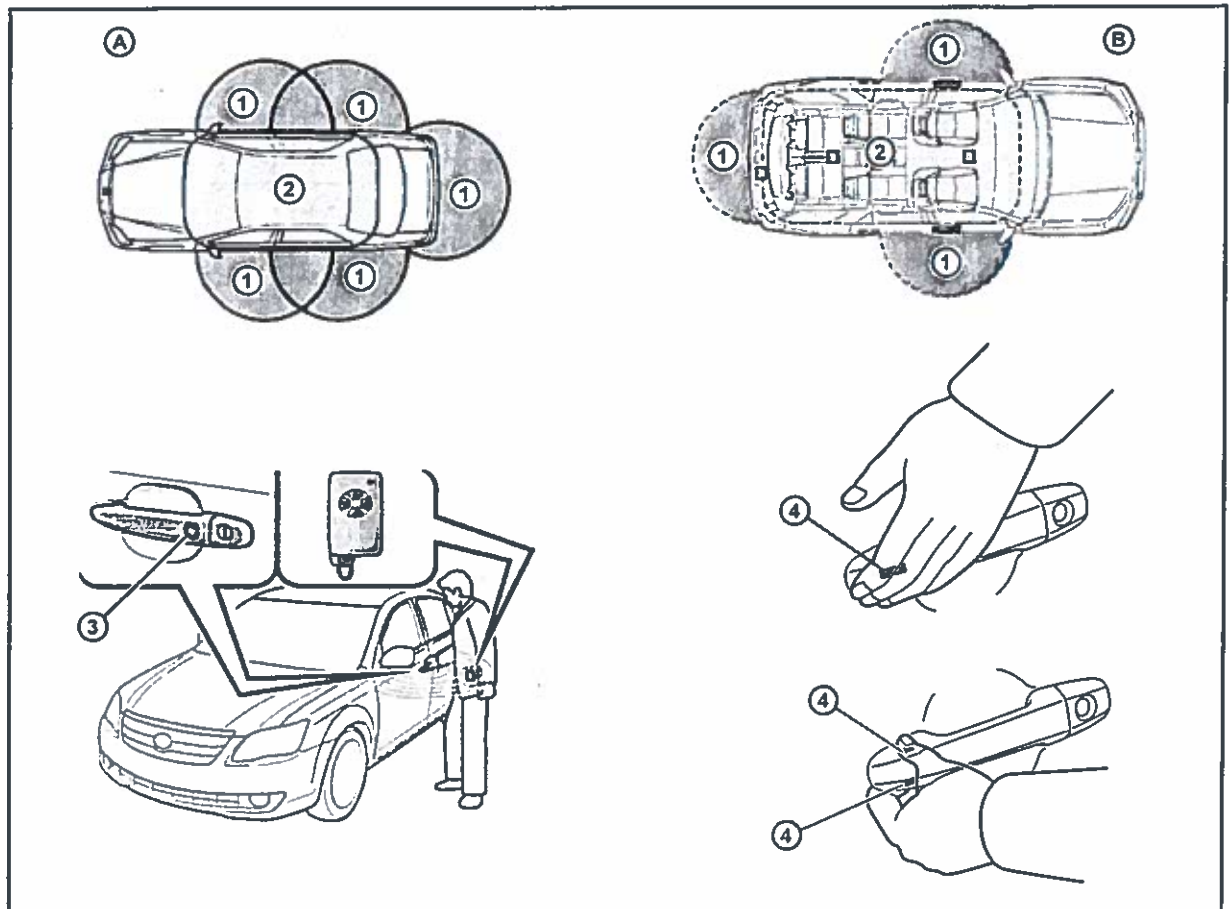

A	4 Door Sensor Vehicles
B	2 Door Sensor Vehicles
1	Actuation Area No. 1

2	Actuation Area No. 2
3	Lock Sensor Button
4	Lock Sensor Area

## Smart Key System Check During PDS

---

### Inspection Procedure (Continued)

#### A. Locking operation:

Push the lock button/lock sensor on the outside door handle. All the doors should lock simultaneously. At this time, one beep will be heard and the turn signal lights will flash once.

#### B. Unlocking operation:

**NOTE**

After checking the lock function, wait at **LEAST 3 seconds** before checking the unlock function.

Grasp the outside door handle (sensors are located on the underside of the door handles). At this time, two beeps will be heard and the turn signal lights will flash twice.

**NOTE**

Only the driver's door unlocks when the driver's door handle is grasped. All the doors unlock when any door handle other than the driver's door handle is grasped.

#### 3. Check the Wireless Door Lock function.

Using the remote outside of the vehicle, confirm that all doors can be locked and unlocked using the wireless remote.

## Smart Key System Check During PDS

### Inspection Procedure (Continued)

4. Check Smart Start function from inside the vehicle.

**NOTE**  
Smart Key **MUST** be in actuation area No. 2 for this check (see Figure 2 below).

Figure 2.

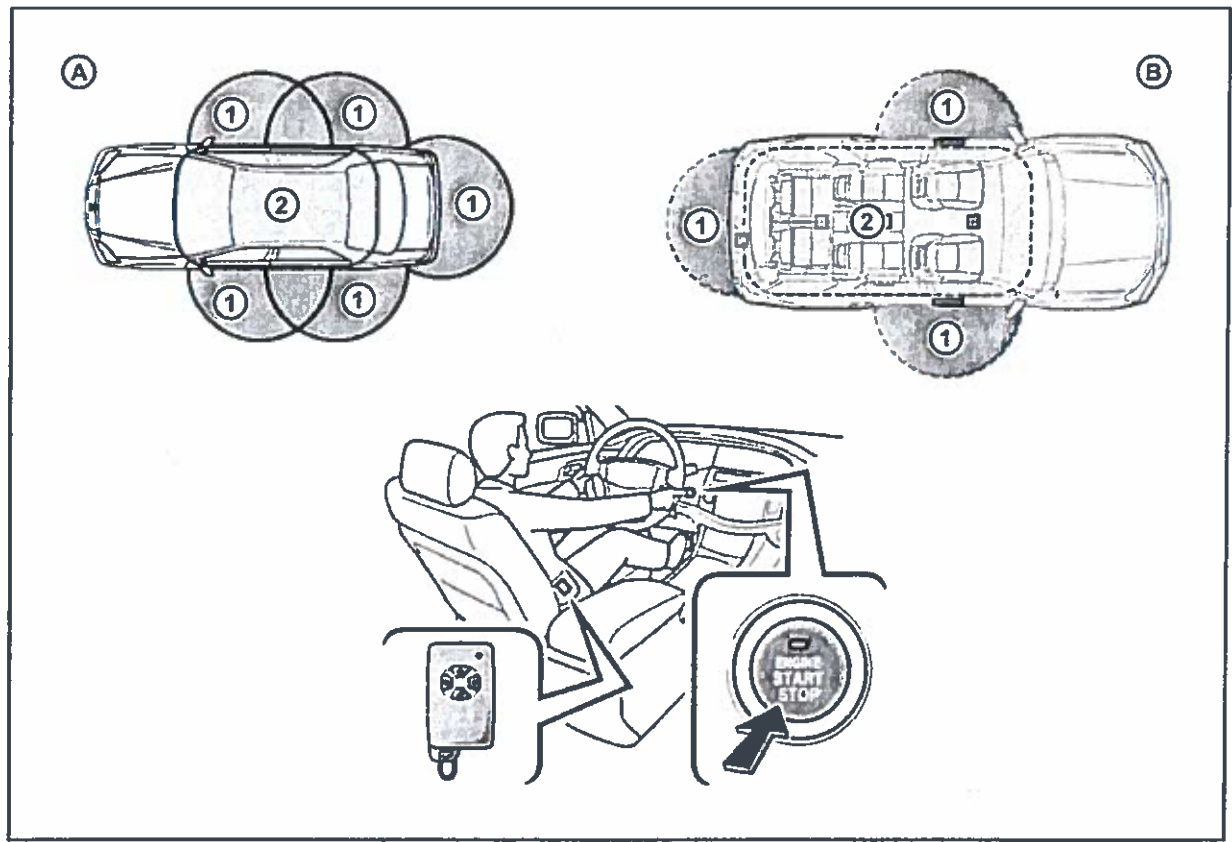

A	4 Door Sensor Vehicles
B	2 Door Sensor Vehicles

1	Actuation Area No. 1
2	Actuation Area No. 2

- A. Check for proper activation of the "ENGINE START/STOP" switch.

- (1) Make sure the gear selector lever is in the "P" position.

## Smart Key System Check During PDS

### Inspection Procedure (Continued)

(2) Without depressing the brake pedal, press the "ENGINE START/STOP" switch and confirm the mode changes properly. From the "OFF" mode:

- Press once. The power supply mode is in the "ACC" mode.
- Press twice. The power supply mode is in the "IG-ON" mode.
- Press three times. The power supply mode is in the "OFF" mode.

**NOTE**

If the "ENGINE START/STOP" switch illuminator blinks in amber, refer to the Repair Manual.

Figure 3. Engine Start/Stop Switch

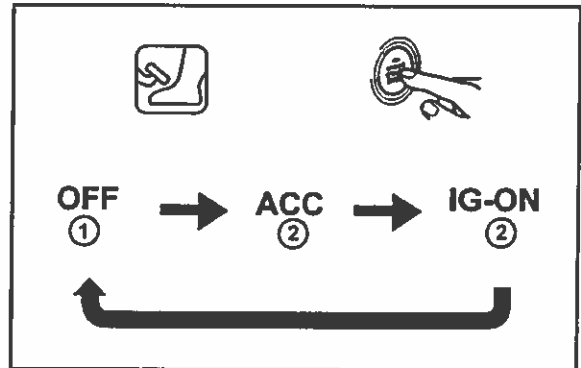

1	Light Off
2	Light On

**B. Check the engine start/stop operation.**

- (1) Make sure that the gear selector lever is in the "P" position.
- (2) When depressing the brake pedal, check that the green engine switch illuminator comes on, and push the "ENGINE START/STOP" switch to start the engine.
- (3) Push the switch again to stop the engine.

**NOTE**

When the "ENGINE START/STOP" switch is turned OFF with the gear selector lever in a position other than "P," the vehicle electrical system will be in the "ACC" mode. When the door is opened the Smart Key System Warning Buzzer will sound indicating that the electrical system is not "OFF" when exiting the vehicle. This may result in a discharged battery. Be sure to turn OFF the engine AFTER shifting the gear selector lever to the "P" position.

**Checking Procedure:**

- Shift the gear selector lever to the "P" position (or check that the gear selector lever is in the "P" position).
- Press the "ENGINE START/STOP" switch once and check that the indicator light goes OFF.

5. Repeat steps 2 – 4 with each Smart Key.

