

**TECHNICAL INSTRUCTIONS
FOR
WARRANTY ENHANCEMENT PROGRAM ZH7**

* * * * *

CERTAIN 2007-2008 MODEL YEAR TUNDRA

* * * * *

FRAME REPLACEMENT

The repair quality of covered vehicles is extremely important to Toyota. All dealership technicians performing this recall are required to successfully complete the most current version of the E-Learning course "Safety Recall and Service Campaign Essentials". To ensure that all vehicles have the repair performed correctly; technicians performing this repair are required to currently hold at least one of the following certification levels:

- Certified Technician (any specialty)
- Expert Technician (any specialty)
- Master Technician
- Master Diagnostic Technician

Final repair must be signed off and validated by a MDT, Shop Foreman or Service Manager using the Frame Replacement Inspection Form.

It is the dealership's responsibility to select technicians with the above certification level or greater to perform this recall repair. Carefully review your resources, the technician skill level, and ability before assigning technicians to this repair. It is important to consider technician days off and vacation schedules to ensure there are properly trained technicians available to perform this repair at all times.

I. OPERATION FLOWCHART

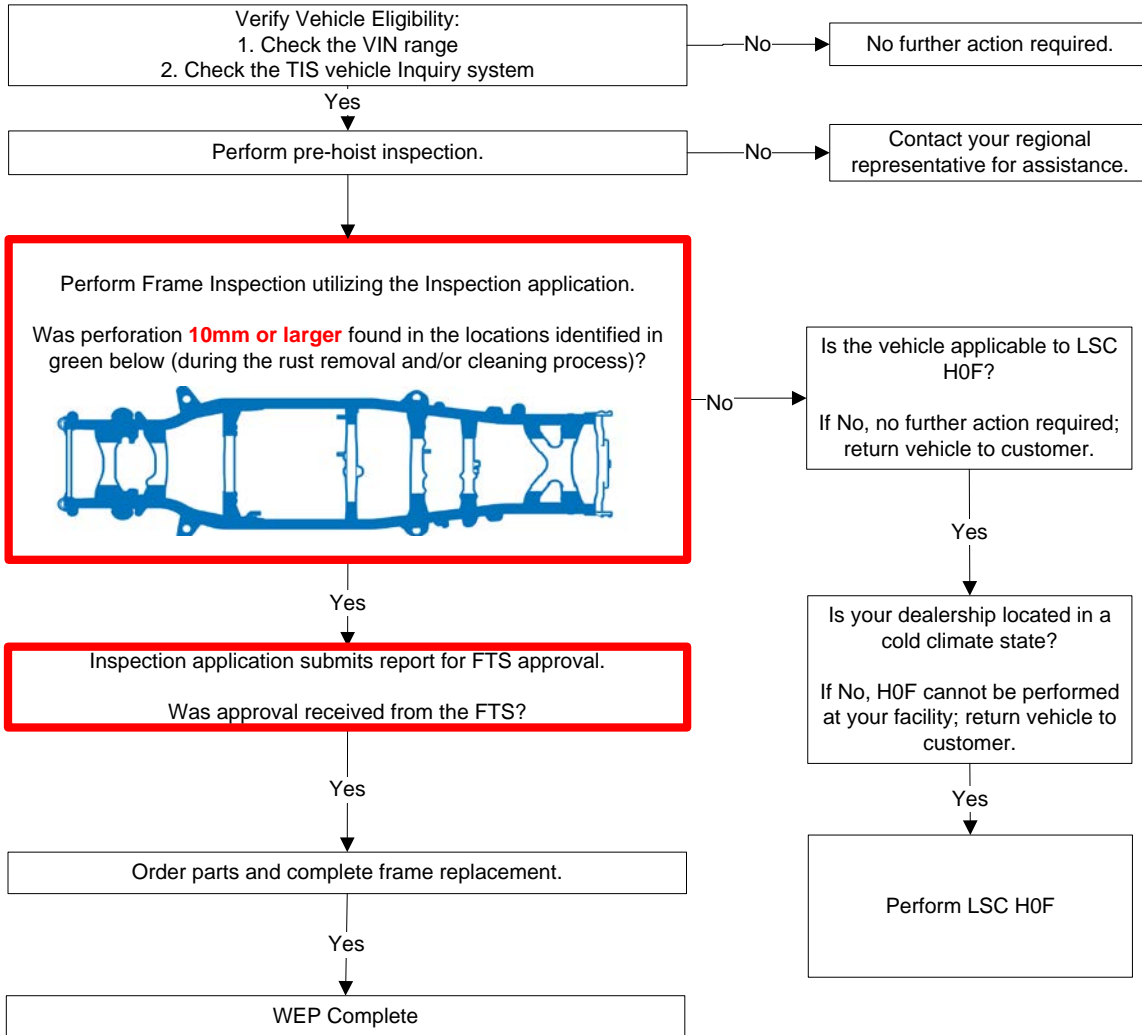

II. PREPARATION

A. TOOLS & EQUIPMENT

- A/C service equipment
- Alignment rack
- Brake bleeder
- Engine Hanger
 - 1GR-FE Engine
 - 12281-31060 – Engine hanger no. 1 (Qty: 1)
 - 12282-31040 – Engine hanger no. 2 (Qty: 1)
 - 90119-08A87 – Bolt (Qty: 4)
 - 3UR-FE Engine
 - 12281-38150 – Engine hanger no. 1 (Qty: 2)
 - 90119-14120 – Bolt (Qty: 2) (Japan sourced parts)
 - 90119-A0166 – Bolt (Qty: 2) (Local sourced parts)
- Engine hoist (Qty: 2) or Hydraulic mini crane (Qty: 2)
- Engine sling (Qty: 2)
- Floor jack
- Protective eyewear
- Protective gloves
- Ratcheting tie down strap (2 in X 27 ft, minimum work load capacity: 3,000 lbs)
- Special Service Tools (SST)
 - 09985-20010 – Air conditioner service tool set **or** Commercially available air conditioning manifold gauge set
 - 09325-40010 – Transmission oil plug (Transmission A750E)
 - 09325-60010 – Transmission oil plug (Transmission AB60E)
 - 09610-20012 – Pitman arm puller
 - 09520-32040 – A component of SST 09520-24010, Differential side gear shaft puller
 - 09520-01010 – Drive shaft remover attachment
 - 09951-04010,09952-04010,09953-04020,09954-04010,09955-04031,09958-04011, – A component of SST 09950-40011, Puller B set
 - 09955-04090 – Crow no.9
 - 09922-10010-01 – Variable open wrench
- Standard hand tools
- Techstream
- Torque wrench
- Torx® T55H tamper resistant socket
- Socket wrench 39mm
- Hexagon wrench 8, 10
- Deep socket wrench 10, 12, 14, 17, 19, 24mm
- Union Nut Wrench 10mm
- Weights

B. SUPPLIES

- Toyota Genuine ATF WS or DEXRON® III (DEXRON® II) – As needed
- Hypoid gear oil API GL-5 SAE 75W-90 – 2.1 liter
- R134a refrigerant – As needed
- Toyota DOT 3 brake fluid – 3 pints
- Toyota long life coolant – 2 gallons
- Paint
- MP Grease

C. PARTS

To assist dealers in determining the correct part number(s) to order, a website has been set up to look up part numbers by VIN. Please go to <http://toyota-frame-parts-lookup.imagespm.info> (also linked through TIS), enter the VIN, and the correct part numbers to order will be displayed. **The website is for part(s) application reference only and will not order the part, nor will it confirm campaign completion status.**

- The parts will need to be ordered through the Dealer Daily Parts system.
- ETAs for the parts will be available via the normal system.
- Frame ETAs will be made available on the Dealer Daily website, in the MAC reference area.

Individual Parts:

| Part Number | Part Description | Quantity | Illustration Name |
|-------------|------------------|----------|-------------------|
| 04004-1510C | Frame, Sub-Assy | 1 | Frame |
| 04004-1520C | Frame, Sub-Assy | 1 | Frame |
| 04004-1530C | Frame, Sub-Assy | 1 | Frame |
| 04004-1540C | Frame, Sub-Assy | 1 | Frame |
| 04004-1550C | Frame, Sub-Assy | 1 | Frame |
| 04004-1560C | Frame, Sub-Assy | 1 | Frame |
| 04004-1570C | Frame, Sub-Assy | 1 | Frame |
| 04004-1580C | Frame, Sub-Assy | 1 | Frame |
| 04004-1590C | Frame, Sub-Assy | 1 | Frame |
| 04004-1610C | Frame, Sub-Assy | 1 | Frame |
| 04004-1620C | Frame, Sub-Assy | 1 | Frame |
| 04004-1630C | Frame, Sub-Assy | 1 | Frame |
| 04004-1640C | Frame, Sub-Assy | 1 | Frame |
| 04004-1650C | Frame, Sub-Assy | 1 | Frame |
| 04004-1660C | Frame, Sub-Assy | 1 | Frame |
| 04004-1670C | Frame, Sub-Assy | 1 | Frame |
| 04004-1680C | Frame, Sub-Assy | 1 | Frame |
| 04004-1690C | Frame, Sub-Assy | 1 | Frame |
| 04004-1710C | Frame, Sub-Assy | 1 | Frame |
| 04004-1720C | Frame, Sub-Assy | 1 | Frame |
| 04004-1730C | Frame, Sub-Assy | 1 | Frame |
| 04004-1740C | Frame, Sub-Assy | 1 | Frame |
| 04004-1750C | Frame, Sub-Assy | 1 | Frame |
| 04004-1760C | Frame, Sub-Assy | 1 | Frame |
| 04004-1770C | Frame, Sub-Assy | 1 | Frame |
| 04004-1780C | Frame, Sub-Assy | 1 | Frame |
| 04004-1790C | Frame, Sub-Assy | 1 | Frame |
| 04004-1810C | Frame, Sub-Assy | 1 | Frame |
| 04004-1820C | Frame, Sub-Assy | 1 | Frame |
| 04004-1830C | Frame, Sub-Assy | 1 | Frame |
| 04004-1840C | Frame, Sub-Assy | 1 | Frame |

Individual Parts (Continued):

| Part Number | Part Description | Quantity | Illustration Name |
|--------------------|--|-----------------|--------------------------|
| 17176-0P010 | Gasket, Airsurge Tank To Intake Manifold | 1 | Exhaust System |
| 47324-0C060 | Tube, Rear Brake, No.4 | 1 | Brake Tubes |
| 47324-0C080 | Tube, Rear Brake, No.4 | 1 | Brake Tubes |
| 47324-0C090 | Tube, Rear Brake, No.4 | 1 | Brake Tubes |
| 47325-0C090 | Tube, Rear Brake, No.5 | 1 | Brake Tubes |
| 47325-0C100 | Tube, Rear Brake, No.5 | 1 | Brake Tubes |
| 47325-0C110 | Tube, Rear Brake, No.5 | 1 | Brake Tubes |
| 48068-09100 | Arm, Sub-Assy, Front Suspension, Lower No.1 RH | 1 | Front Suspension |
| 48069-09090 | Arm, Sub-Assy, Front Suspension, Lower No.1 LH | 1 | Front Suspension |
| 48210-0C090 | Spring Assy, Rear RH | 1 | Rear Suspension |
| 48210-0C100 | Spring Assy, Rear RH | 1 | Rear Suspension |
| 48210-0C101 | Spring Assy, Rear RH | 1 | Rear Suspension |
| 48210-0C110 | Spring Assy, Rear RH | 1 | Rear Suspension |
| 48210-0C120 | Spring Assy, Rear RH | 1 | Rear Suspension |
| 48210-0C130 | Spring Assy, Rear RH | 1 | Rear Suspension |
| 48210-0C131 | Spring Assy, Rear RH | 1 | Rear Suspension |
| 48210-0C140 | Spring Assy, Rear RH | 1 | Rear Suspension |
| 48210-0C150 | Spring Assy, Rear RH | 1 | Rear Suspension |
| 48210-0C160 | Spring Assy, Rear RH | 1 | Rear Suspension |
| 48210-0C170 | Spring Assy, Rear RH | 1 | Rear Suspension |
| 48210-0C180 | Spring Assy, Rear RH | 1 | Rear Suspension |
| 48210-0C190 | Spring Assy, Rear RH | 1 | Rear Suspension |
| 48210-0C210 | Spring Assy, Rear RH | 1 | Rear Suspension |
| 48210-0C220 | Spring Assy, Rear RH | 1 | Rear Suspension |
| 48210-0C230 | Spring Assy, Rear RH | 1 | Rear Suspension |
| 48210-0C240 | Spring Assy, Rear RH | 1 | Rear Suspension |
| 48210-0C250 | Spring Assy, Rear RH | 1 | Rear Suspension |
| 48210-0C260 | Spring Assy, Rear RH | 1 | Rear Suspension |
| 48210-0C280 | Spring Assy, Rear RH | 1 | Rear Suspension |
| 48210-0C290 | Spring Assy, Rear RH | 1 | Rear Suspension |
| 48210-0C300 | Spring Assy, Rear RH | 1 | Rear Suspension |
| 48210-0C310 | Spring Assy, Rear RH | 1 | Rear Suspension |
| 48210-0C320 | Spring Assy, Rear RH | 1 | Rear Suspension |
| 48210-0C330 | Spring Assy, Rear RH | 1 | Rear Suspension |
| 48210-0C340 | Spring Assy, Rear RH | 1 | Rear Suspension |
| 48210-0C350 | Spring Assy, Rear RH | 1 | Rear Suspension |
| 48220-0C090 | Spring Assy, Rear LH | 1 | Rear Suspension |
| 48220-0C100 | Spring Assy, Rear LH | 1 | Rear Suspension |
| 48220-0C101 | Spring Assy, Rear LH | 1 | Rear Suspension |
| 48220-0C110 | Spring Assy, Rear LH | 1 | Rear Suspension |
| 48220-0C120 | Spring Assy, Rear LH | 1 | Rear Suspension |
| 48220-0C130 | Spring Assy, Rear LH | 1 | Rear Suspension |
| 48220-0C131 | Spring Assy, Rear LH | 1 | Rear Suspension |
| 48220-0C140 | Spring Assy, Rear LH | 1 | Rear Suspension |
| 48220-0C150 | Spring Assy, Rear LH | 1 | Rear Suspension |
| 48220-0C160 | Spring Assy, Rear LH | 1 | Rear Suspension |

Individual Parts (Continued):

| Part Number | Part Description | Quantity | Illustration Name |
|--------------------|---|-----------------|--------------------------|
| 48220-0C170 | Spring Assy, Rear LH | 1 | Rear Suspension |
| 48220-0C180 | Spring Assy, Rear LH | 1 | Rear Suspension |
| 48220-0C190 | Spring Assy, Rear LH | 1 | Rear Suspension |
| 48220-0C210 | Spring Assy, Rear LH | 1 | Rear Suspension |
| 48220-0C220 | Spring Assy, Rear LH | 1 | Rear Suspension |
| 48220-0C230 | Spring Assy, Rear LH | 1 | Rear Suspension |
| 48220-0C240 | Spring Assy, Rear LH | 1 | Rear Suspension |
| 48220-0C250 | Spring Assy, Rear LH | 1 | Rear Suspension |
| 48220-0C260 | Spring Assy, Rear LH | 1 | Rear Suspension |
| 48220-0C280 | Spring Assy, Rear LH | 1 | Rear Suspension |
| 48220-0C290 | Spring Assy, Rear LH | 1 | Rear Suspension |
| 48220-0C300 | Spring Assy, Rear LH | 1 | Rear Suspension |
| 48220-0C310 | Spring Assy, Rear LH | 1 | Rear Suspension |
| 48220-0C320 | Spring Assy, Rear LH | 1 | Rear Suspension |
| 48220-0C330 | Spring Assy, Rear LH | 1 | Rear Suspension |
| 48220-0C340 | Spring Assy, Rear LH | 1 | Rear Suspension |
| 48220-0C350 | Spring Assy, Rear LH | 1 | Rear Suspension |
| 51900-34050 | Carrier Assy, Spare Wheel | 1 | Spare Tire Carrier |
| 77412-34010 | Clamp, Fuel Tube, No.4 | 1 | Fuel Tubes |
| 77412-34010 | Clamp, Fuel Tube, No.4 | 2 | Fuel Tubes |
| 77412-34010 | Clamp, Fuel Tube, No.4 | 3 | Fuel Tubes |
| 82164-0C870 | Wire, Frame | 1 | Wire Harness Clamps |
| 82164-0CA00 | Wire, Frame | 1 | Wire Harness Clamps |
| 82164-0C890 | Wire, Frame | 1 | Wire Harness Clamps |
| 90080-11373 | Bolt | 2 | Fuel Tank |
| 90080-11717 | Bolt | 16 | Front Bumper |
| 90080-17229 | Nut | 1 | AT Shift Cable |
| 90080-46263 | Clamp | 1 | Exhaust System |
| 90105-A0179 | Bolt | 1 | Engine Mounting |
| 90105-A0179 | Bolt | 3 | Fuel Tubes |
| 90105-A0179 | Bolt | 4 | Fuel Tubes |
| 90105-A0179 | Bolt | 5 | Fuel Tubes |
| 90117-A0003 | Bolt, U (For Rear Spring) | 4 | Rear Suspension |
| 90117-A0004 | Bolt, U (For Rear Spring) | 4 | Rear Suspension |
| 90119-A0169 | Bolt | 5 | Under Cover |
| 90119-A0169 | Bolt | 2 | Under Cover |
| 90119-A0170 | Bolt | 1 | Engine Mounting |
| 90119-A0219 | Bolt | 4 | Rear Bumper |
| 90119-A0219 | Bolt | 10 | Rear Bumper |
| 90119-A0271 | Bolt | 4 | Rear Bumper |
| 90119-A0271 | Bolt | 2 | Rear Bumper |
| 90126-A0011 | Bolt, Stud (For Exhaust Manifold, RH) | 3 | Exhaust System |
| 90126-A0011 | Bolt, Stud (For Exhaust Manifold, LH) | 3 | Exhaust System |
| 90126-A0011 | Bolt, Stud (For Manifold To Exhaust Pipe) | 6 | Exhaust System |
| 90189-06236 | Clip | 4 | Front Fender |

Individual Parts (Continued):

| Part Number | Part Description | Quantity | Illustration Name |
|-------------|------------------------------|----------|-------------------|
| 90461-15017 | Clamp | 1 | Exhaust System |
| 90469-A0004 | Clamp, Brake Tube, No.7 | 7 | Brake Tubes |
| 90469-A0004 | Clamp, Brake Tube, No.7 | 8 | Brake Tubes |
| 90469-A0004 | Clamp, Brake Tube, No.7 | 9 | Brake Tubes |
| 90917-06085 | Gasket, Exhaust Pipe, Center | 1 | Exhaust System |
| 90917-06093 | Gasket, Exhaust Pipe, Center | 1 | Exhaust System |
| 47312-0C080 | TUBE, FR BRAKE, NO.2 | 1 | Brake Tubes |
| 47313-0C090 | TUBE, FR BRAKE, NO.3 | 1 | Brake Tubes |
| 47322-0C110 | TUBE, RR BRAKE, NO.2 | 1 | Brake Tubes |
| 47323-0C090 | TUBE, RR BRAKE, NO.3 | 1 | Brake Tubes |

Parts Kits:

| Part Number | Part Description | Quantity |
|-------------|---|----------|
| 04004-19134 | Parts Kit No.1 – Common Replacement Kit A | 1 |

The kit listed above includes the following parts:

| Part Number | Part Description | Quantity | Illustration Name | Page |
|-------------|---|----------|-------------------|-------|
| 48190-34010 | Cam Assy, Camber Adjust | 2 | Front Suspension | 11 |
| 48198-34010 | Cam, Camber Adjust, No.2 | 2 | Front Suspension | 11 |
| 48409-34041 | Cam Sub-Assy, Front Suspension Toe Adjust | 2 | Front Suspension | 11 |
| 48452-34011 | Plate, Front Suspension Toe Adjust, No.2 | 2 | Front Suspension | 11 |
| 77285-34370 | Clamp, Fuel Tube, No.2 | 3 | Fuel Tubes | 17 |
| 77289-26010 | Clamp, Fuel Tube, No.1 | 1 | Fuel Tubes | 17 |
| 77413-34010 | Clamp, Fuel Tube, No.5 | 1 | Fuel Tubes | 17 |
| 90099-14120 | O-Ring | 1 | Air Conditioning | 26 |
| 90178-18003 | Nut | 2 | Front Suspension | 11 |
| 90179-06178 | Nut | 6 | Front Bumper | 26 |
| 90201-19011 | Washer | 2 | Front Suspension | 11 |
| 90252-04003 | Cotter Pin | 2 | Power Steering | 19 |
| 90412-10266 | Way, No.1 (For Front Brake Tube) | 1 | Brake Tubes | 13-15 |
| 90412-10267 | Way, No.2 (For Front Brake Tube) | 1 | Brake Tubes | 13-15 |
| 90412-10268 | Way (For Rear Brake Tube) | 1 | Brake Tubes | 13-15 |
| 94622-51400 | Washer | 10 | Rear Suspension | 12 |

| Part Number | Part Description | Quantity |
|-------------|------------------|----------|
| 04007-18134 | Plug, Hole Kit | 1 |

The kit listed above includes the following parts:

| Part Number | Part Description | Quantity |
|-------------|------------------|----------|
| 90950-01993 | PLUG HOLE | 6 |
| 90950-01994 | PLUG HOLE | 6 |
| 90950-01A09 | PLUG HOLE | 6 |
| 90950-01987 | PLUG HOLE | 6 |
| 90950-01988 | PLUG HOLE | 2 |
| 9095001A06 | PLUG HOLE | 2 |
| 90950-01990 | PLUG HOLE | 2 |
| 90950-01A11 | PLUG HOLE | 2 |
| 90950-01A24 | PLUG HOLE | 2 |

| Part Number | Part Description | Quantity |
|-------------|------------------|----------|
| 90950-01A31 | PLUG,HOLE | 2 |

Parts Kits:

| Part Number | Part Description | Quantity |
|-------------|---|----------|
| 04004-1920C | Parts Kit No.2 – Common Replacement Kit B | 1 |

The kit listed above includes the following parts:

| Part Number | Part Description | Quantity |
|----------------------------------|------------------------------------|----------|
| 04483-0C040 | Shackle Kit, Rear Spring RH | 1 |
| 04483-0C040 | Shackle Kit, Rear Spring LH | 1 |
| 16492-21050 | Packing (For Radiator Drain Cock) | 1 |
| 47314-0C020 | Tube, Front Brake No.4 | 1 |
| 47315-0C030 or 47315-0C031 | Tube, Front Brake No.5 | 1 |
| 48304-0C030 | Bumper, Front Spring, No.1 RH | 2 |
| 48304-0C030 | Bumper, Front Spring, No.1 LH | 2 |
| 52238-0C010 | Holder, Body Mounting, Rear | 2 |
| 77272-0C030 | Support, Breather Tube, No.1 | 1 |
| 77285-34380 | Clamp, Fuel Tube, No.1 | 3 |
| 77296-0C010 or 77296-0C020 | Clamp, Fuel Tube, No.3 | 1 |
| 77414-0C010 | Clamp, Fuel Tube, No.6 | 1 |
| 90069-08009 | O-Ring | 1 |
| 90080-10138 or 90105-A0381 | Bolt | 2 |
| 90080-11555 | Bolt | 1 |
| 90080-17187 | Nut | 6 |
| 90080-46327 | Clip (For Front Fender Apron Seal) | 22 |
| 90105-A0064 | Bolt | 3 |
| 90119-A0380 | Bolt | 1 |
| 90119-A0077 | Bolt | 2 |
| 90119-A0080 | Bolt | 8 |
| 90119-A0169 | Bolt | 2 |
| 90119-A0169 | Bolt | 4 |
| 90119-A0184 | Bolt | 1 |
| 90119-A0192 | Bolt | 4 |
| 90119-A0204 | Bolt | 2 |
| 90119-A0210 | Bolt | 4 |
| 90119-A0222 | Bolt | 2 |
| 90119-A0224 | Bolt | 4 |
| 90178-A0044 | Nut | 8 |
| 90178-A0049 | Nut | 2 |
| 90178-A0050 | Nut | 10 |
| 90178-A0052 | Nut (For Front Suspension) | 8 |
| 90178-A0067 | Nut | 6 |
| 90178-A0071 | Nut | 2 |
| 90468-A0007 | Clip | 4 |
| 90917-A6002 | Gasket, Exhaust Pipe | 2 |

| Part Number | Part Description | Quantity |
|---|---|-----------------|
| 04004-19334 | Parts Kit No.3 – JPN Source Parts Kit 4WD | 1 |
| The kit listed above includes the following parts: | | |
| Part Number | Part Description | Quantity |
| 12157-10010 | Gasket, Front Differential Filler Plug | 1 |
| 43514-34020 | Cap, Front Axle Hub Grease, RH | 1 |
| 43514-34020 | Cap, Front Axle Hub Grease, RH | 1 |
| 90311-47012 or 90311-47027 | Seal, Oil (For Differential Side Gear Shaft | 1 |
| 90311-47013 | Seal, Oil (For Differential Side Gear Shaft | 1 |
| 90430-24003 | Gasket, (For Front Differential Drain Plug | 1 |
| 95381-04050 | Cotter Pin | 2 |

| Part Number | Part Description | Quantity | | |
|---|--|-----------------|--------------------------|-------------|
| 04004-1940C | Parts Kit No.4 – USA Source Parts Kit 4WD | 1 | | |
| The kit listed above includes the following parts: | | | | |
| Part Number | Part Description | Quantity | Illustration Name | Page |
| 43425-0C010 | Ring, Shaft Snap (For Front Drive Inner Shaft Outer) | 2 | Front Suspension | 11 |
| 90105-A0193 | Bolt | 1 | Front Differential | 19 |
| 90119-A0151 | Bolt | 2 | Propeller Shaft | 20 |
| 90464-00897 | Clamp | 1 | Front Differential | 19 |

D. PARTS ILLUSTRATION

Frame

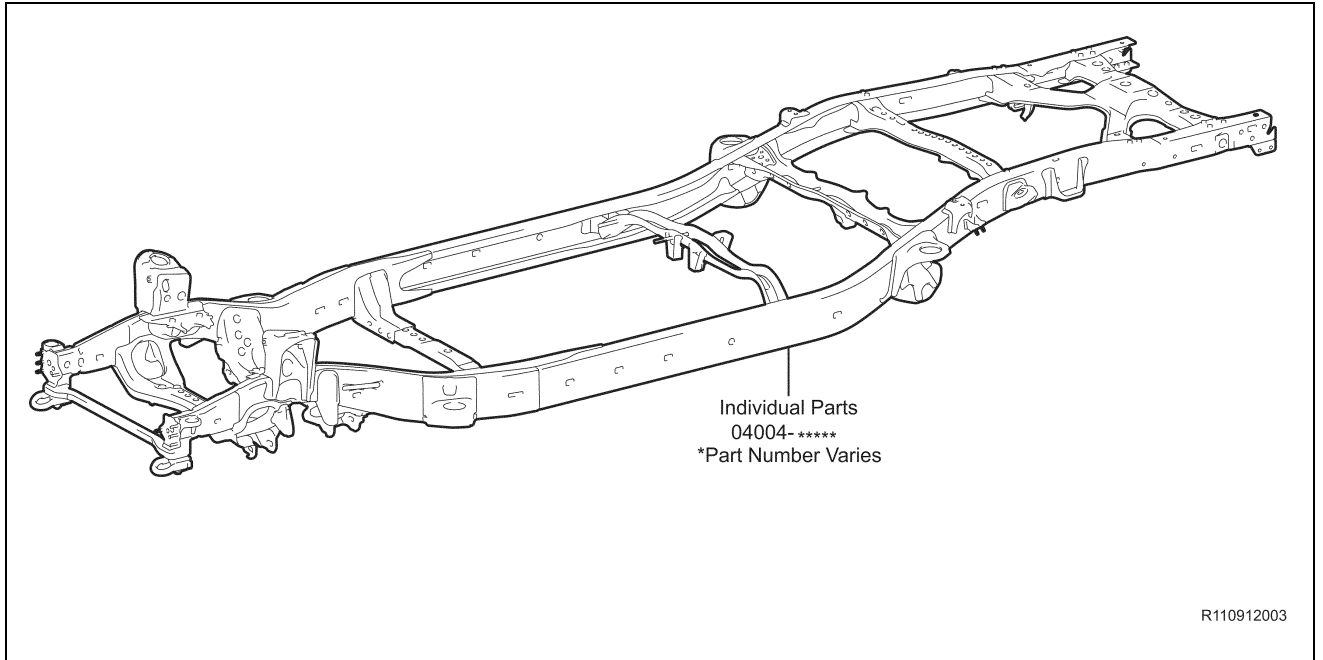

Frame & Cab Mounting

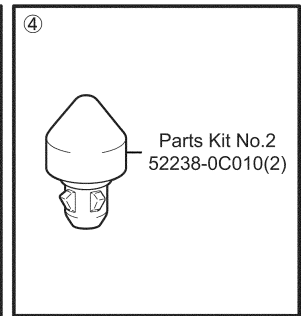
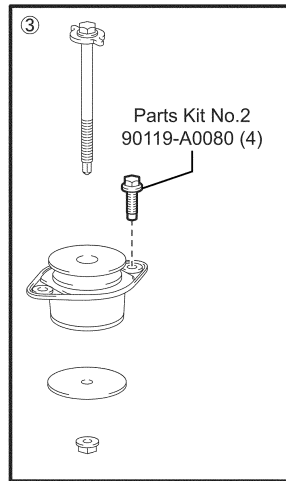
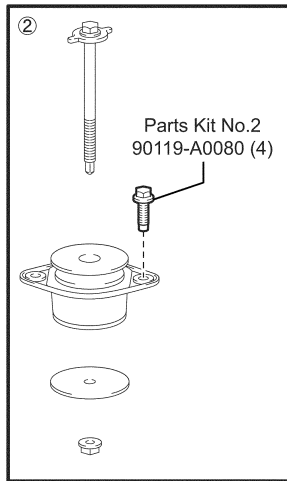
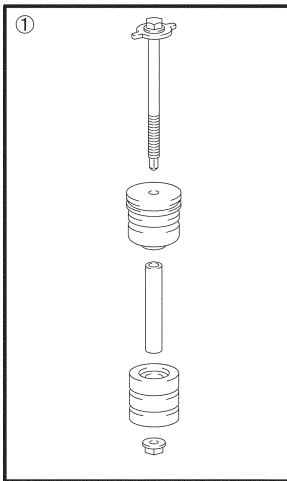
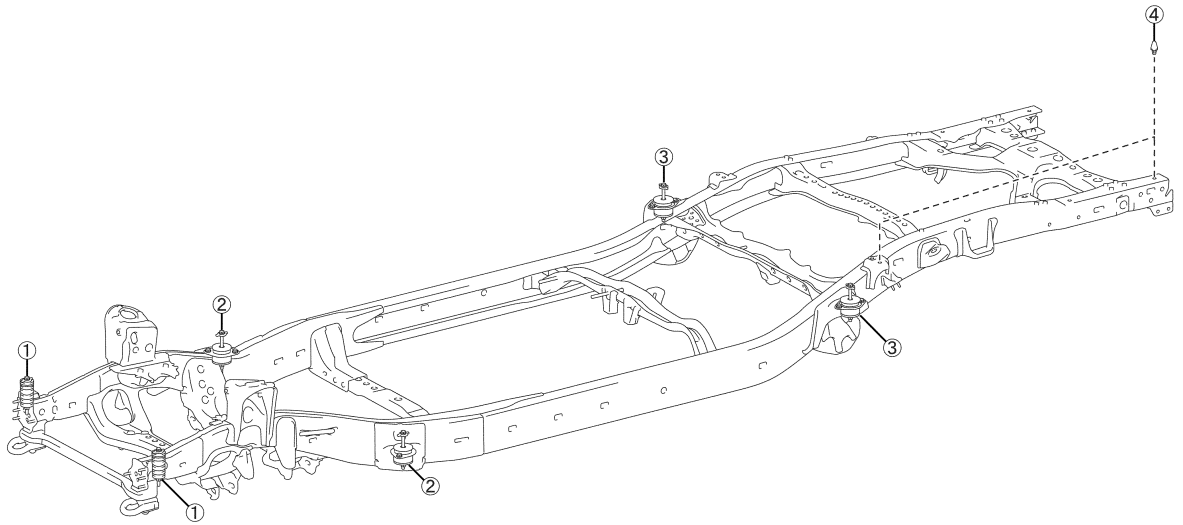

R1109120004

Under Cover

FRONT BUMPER CHROME PLATED TYPE :

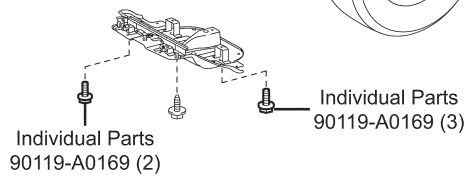
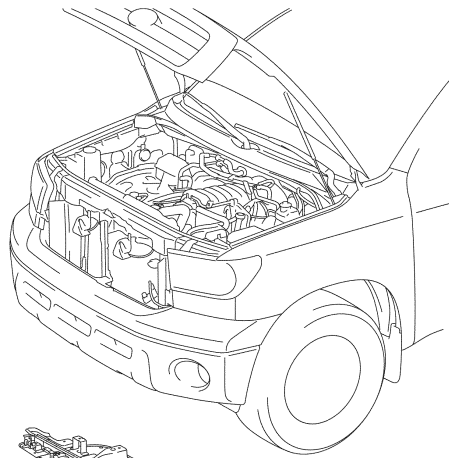

FRONT BUMPER RESIN TYPE :

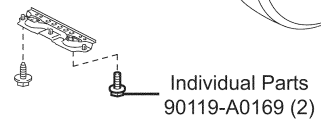
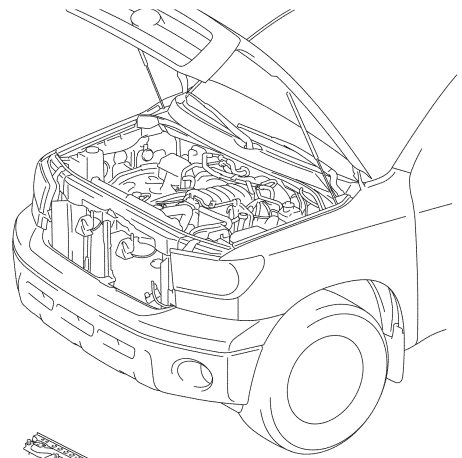

R1109120005

Spare Tire Carrier

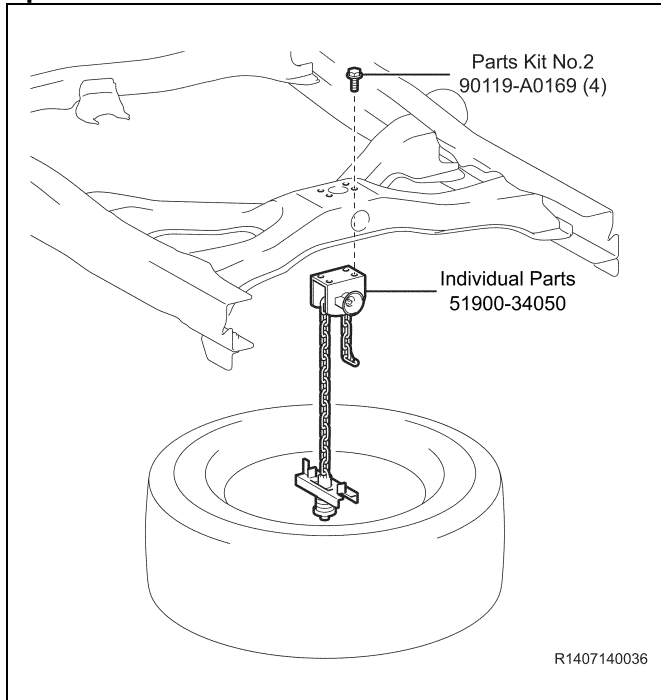

R1407140036

Front Suspension

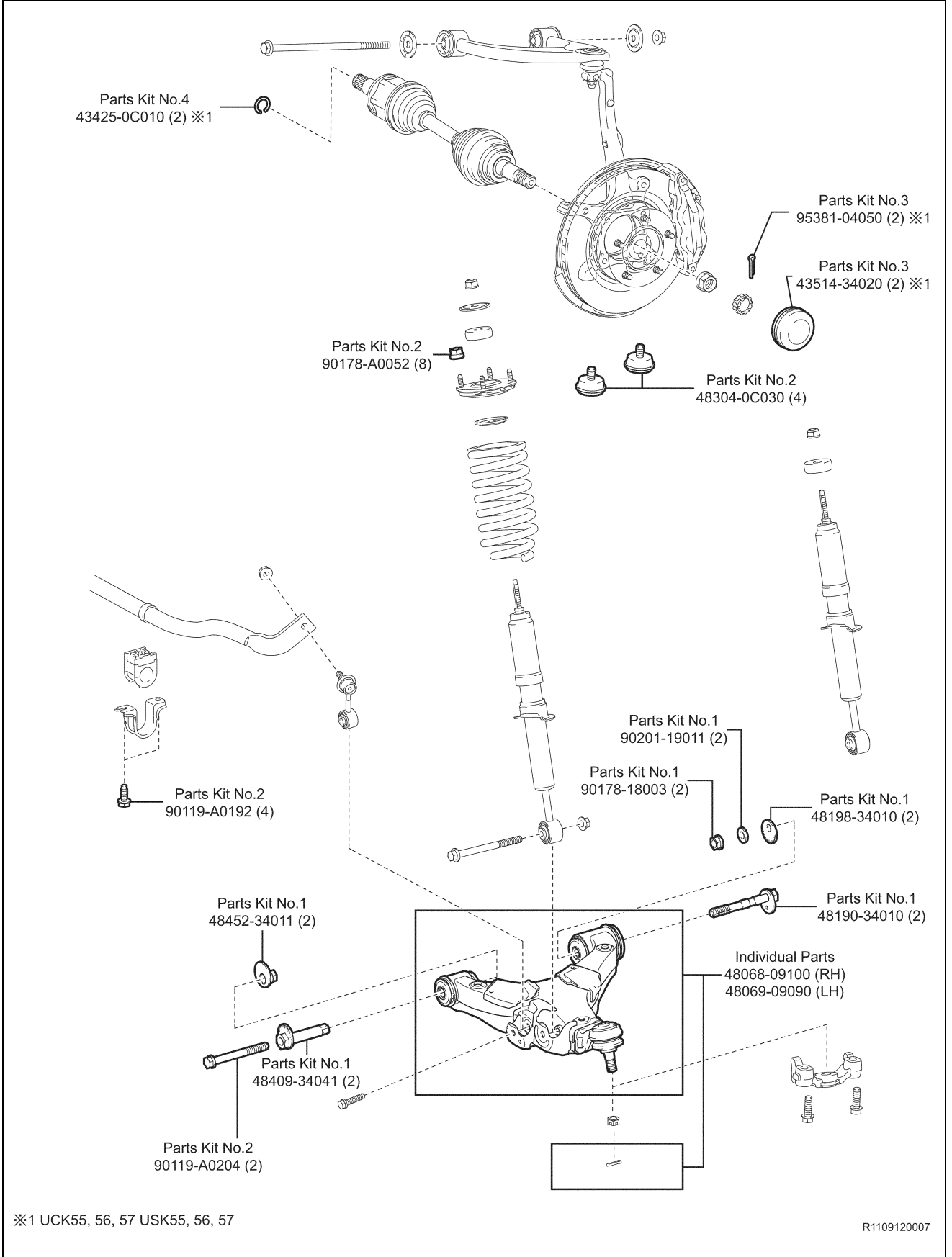

Rear Suspension

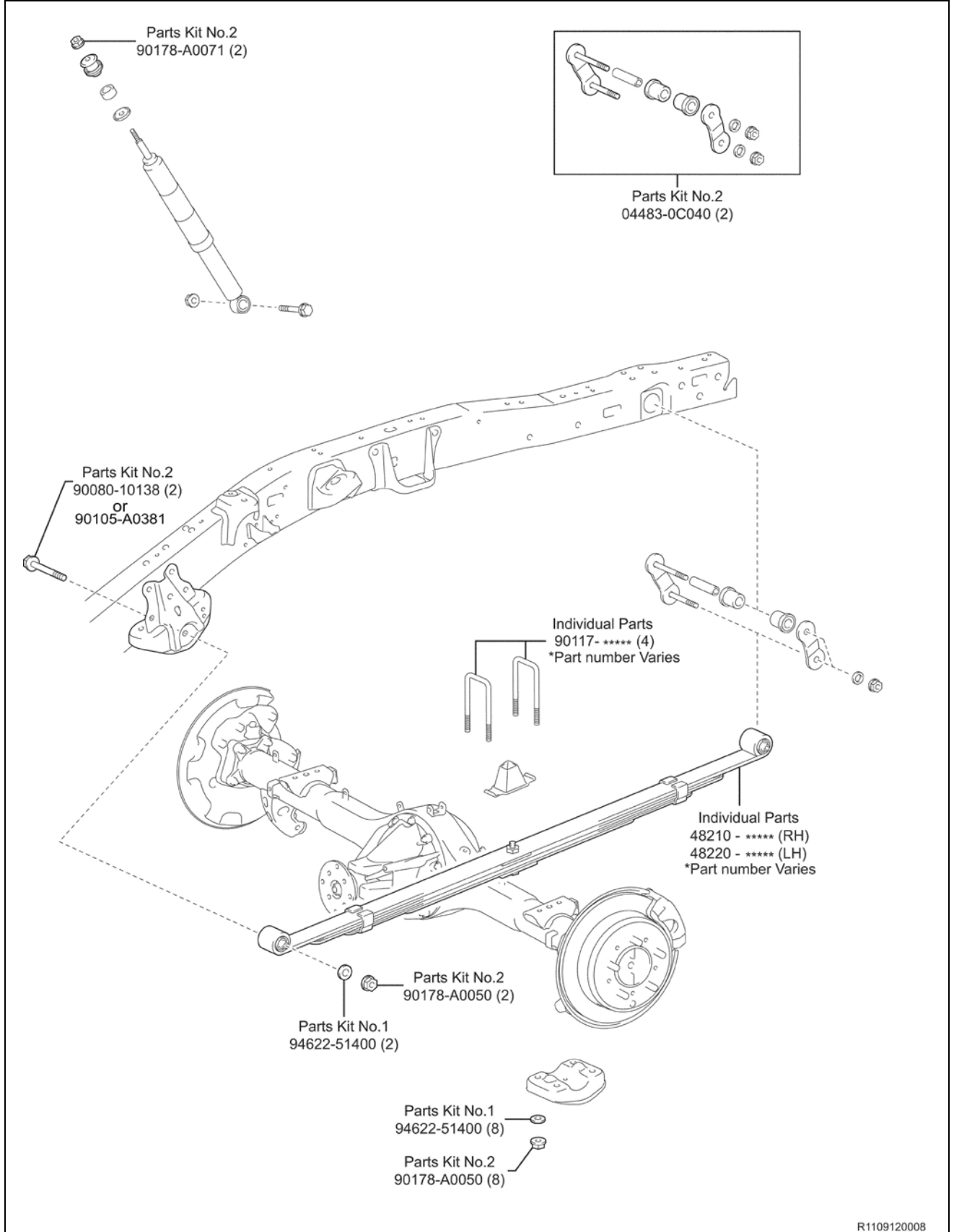

Brake Tubes

REGULAR CAB (STANDARD BED)

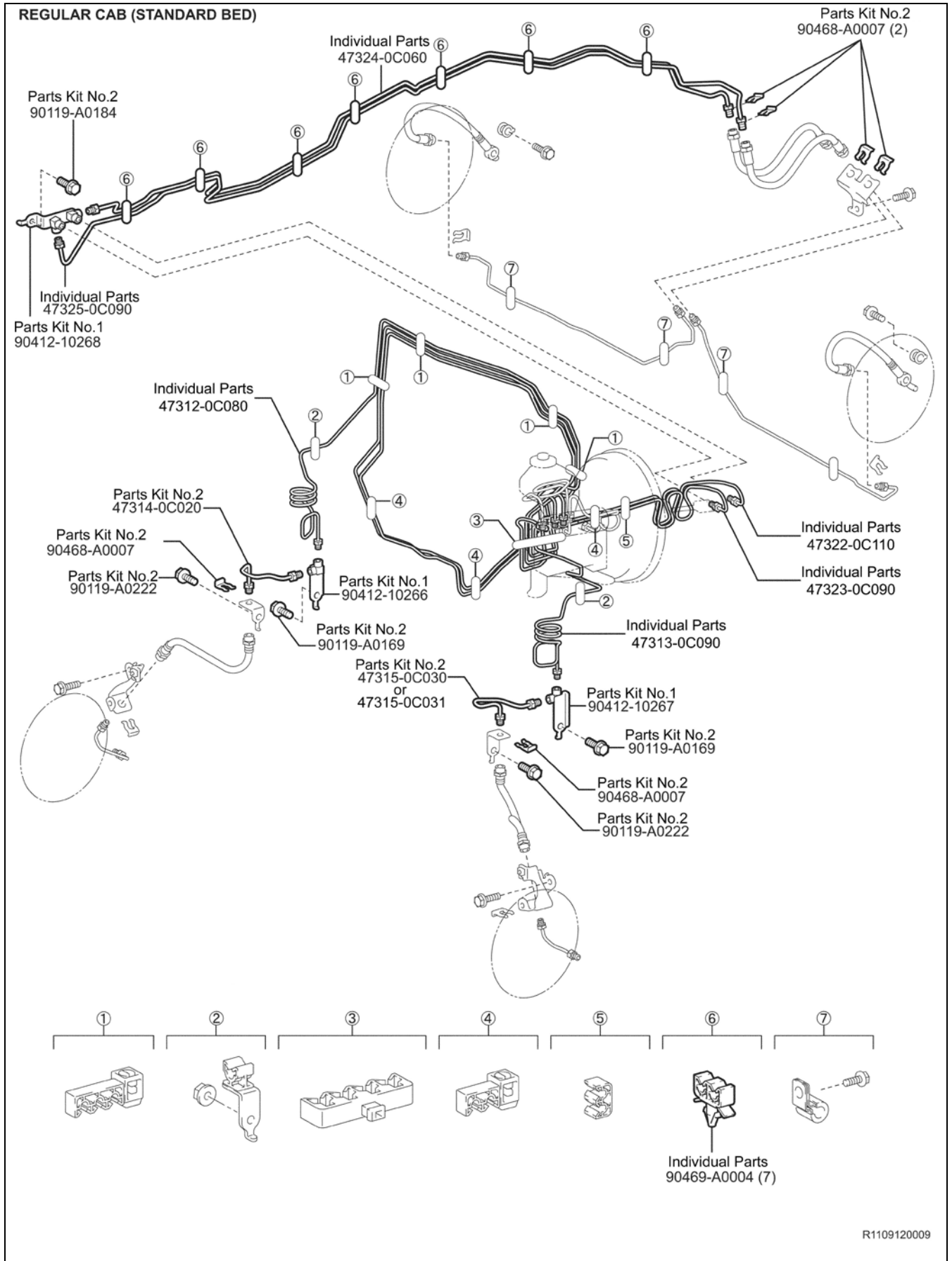

R1109120009

Brake Tubes Continued...

REGULAR CAB (LONG BED)
 DOUBLE CAB (STANDARD BED)
 CREW MAX

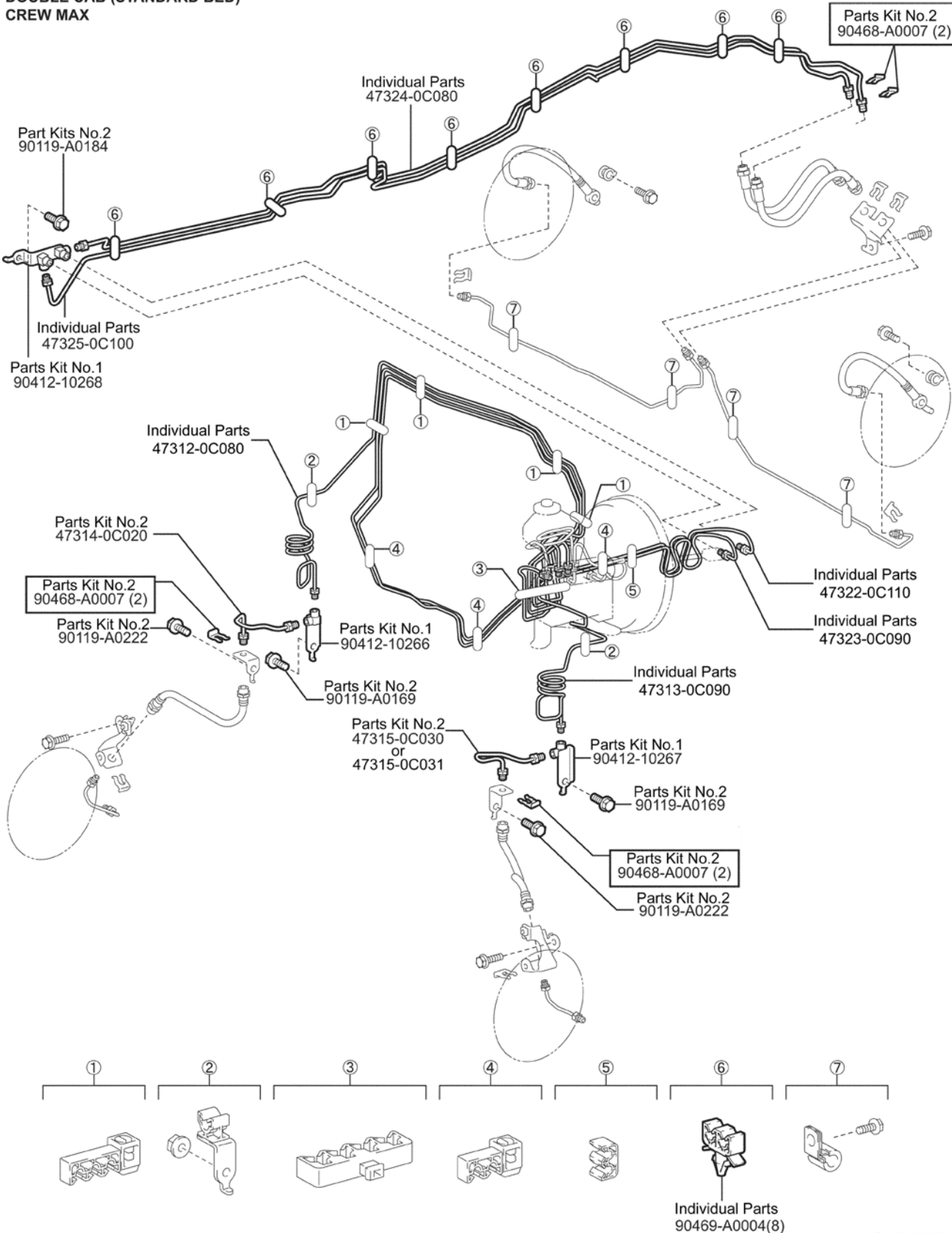

R1109120010

Brake Tubes Continued...

DOUBLE CAB (LONG BED)

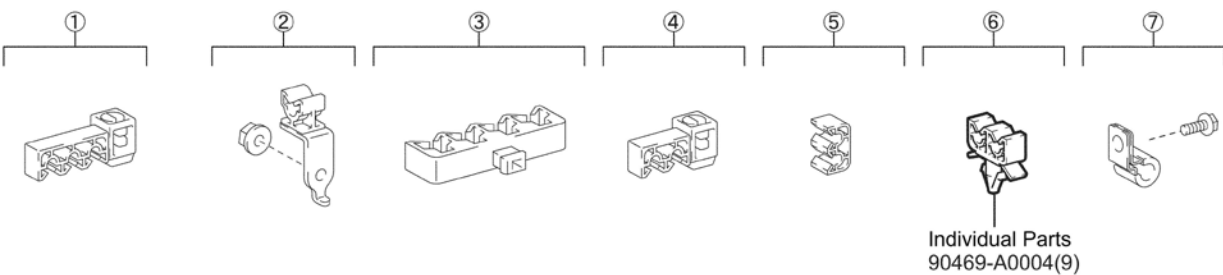
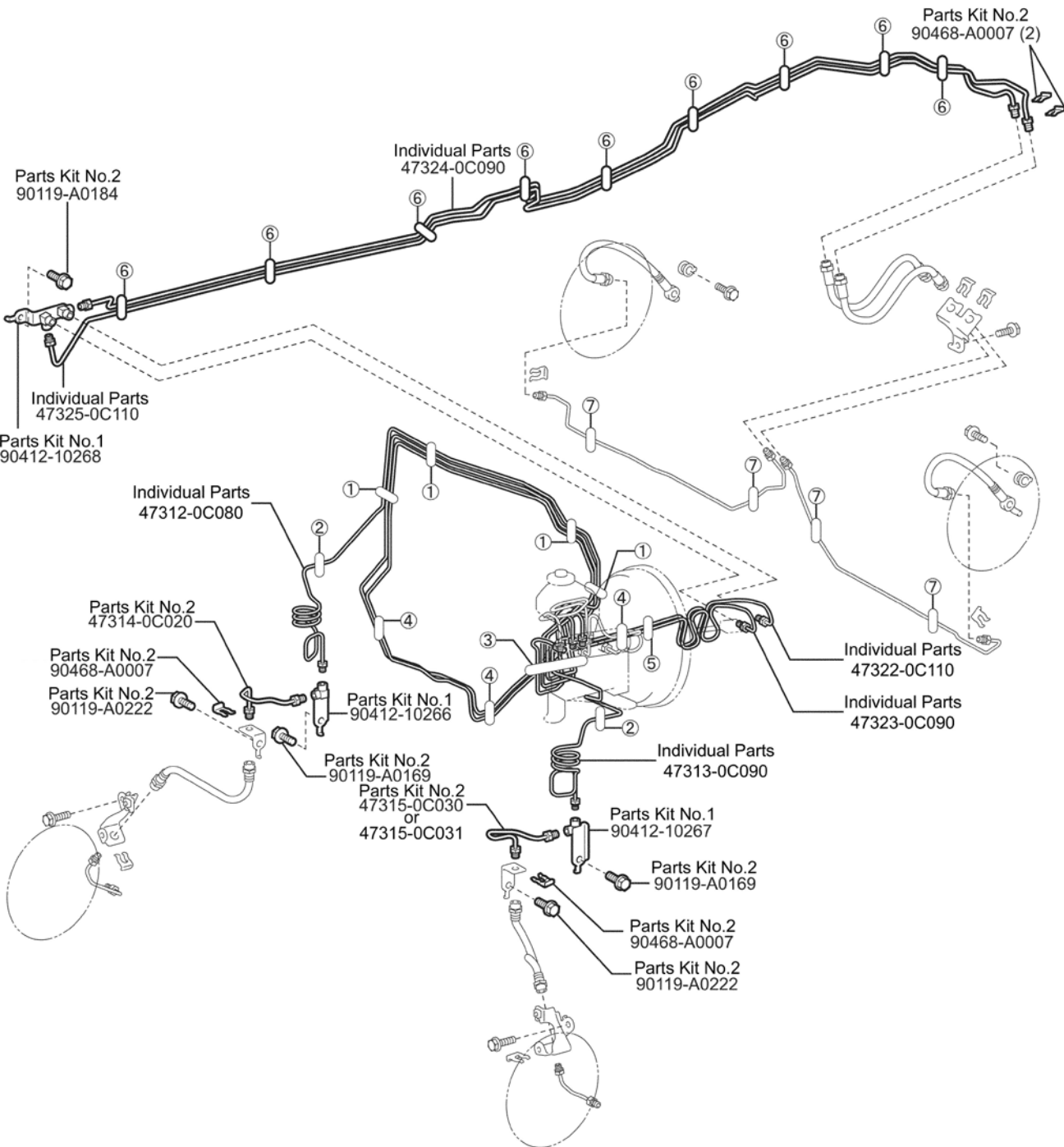

Fuel Tank

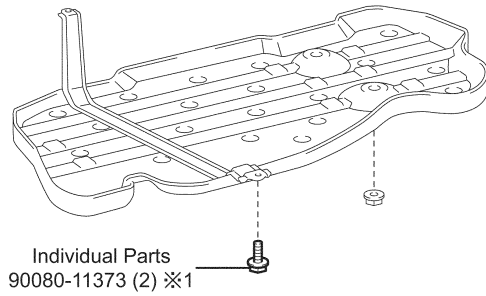
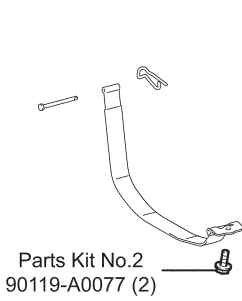
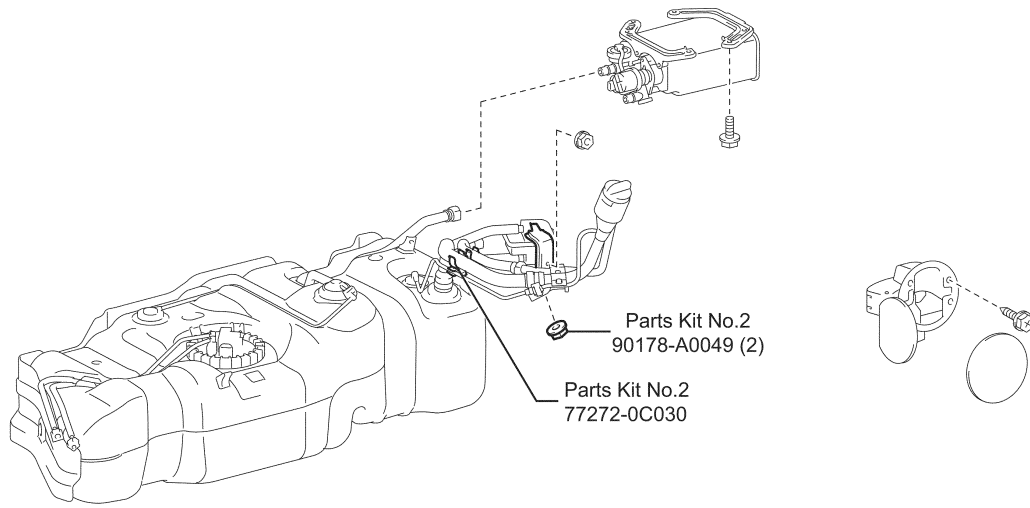

※1 OFFROAD PACKAGE

RR1109120012

Fuel Tubes

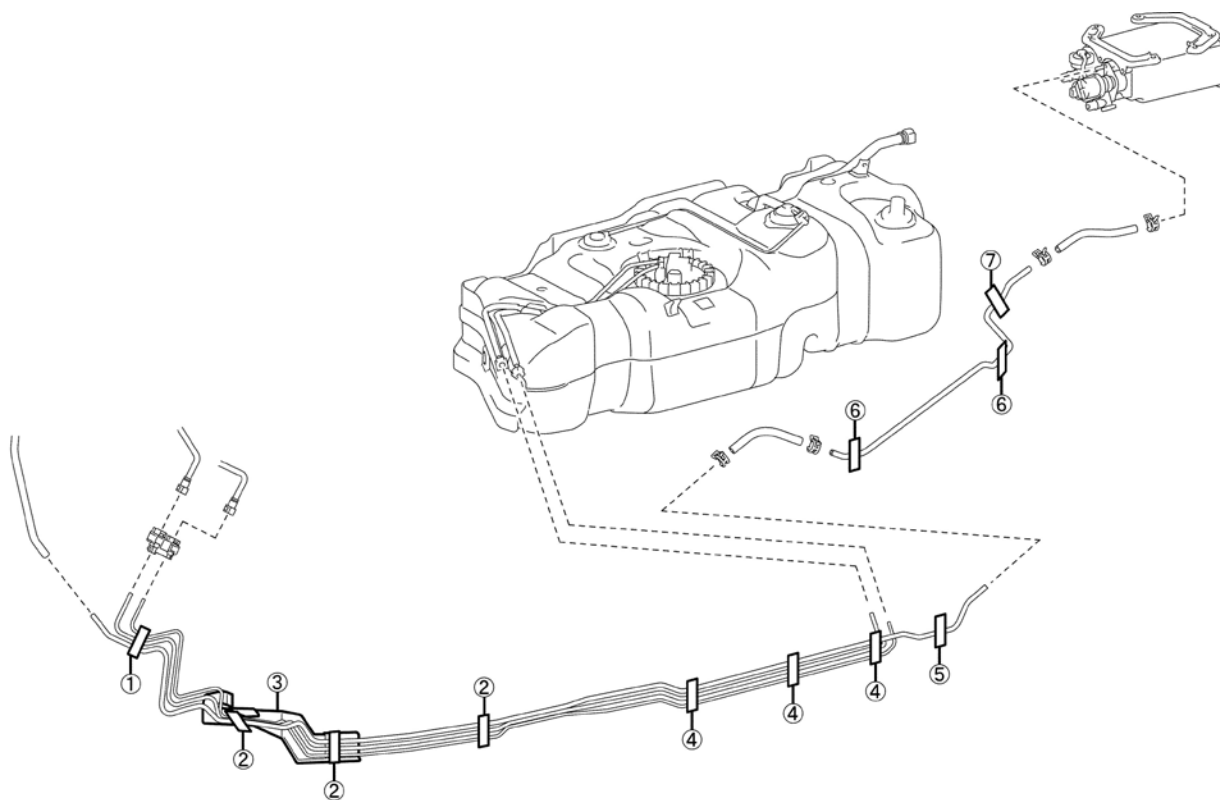

①
Parts Kit No.1
77289-26010



②
Parts Kit No.1
7285-34370 (3)



③
Parts Kit No.2
77296-0C010
or
77296-0C020

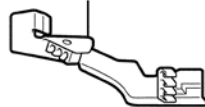

④
Individual Parts
90105-A0179 (1) ※1
90105-A0179 (2) ※2
90105-A0179 (3) ※3



⑤
Individual Parts
90105-A 0179



Parts Kit No.1
77413-34010

⑥
Parts Kit No.2
77285-34380 (2)



⑦
Parts Kit No.2
77285-34380
Parts Kit No.2
77414-0C010

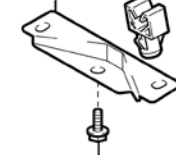

Individual Parts
90105-A0179

- ※1 REGULAR CAB (STANDARD BED)
- ※2 REGULAR CAB (LONG BED)
DOUBLE CAB (STANDARD BED)
CREW MAX
- ※3 DOUBLE CAB (LONG BED)

R1109120013

Wire Harness Clamps

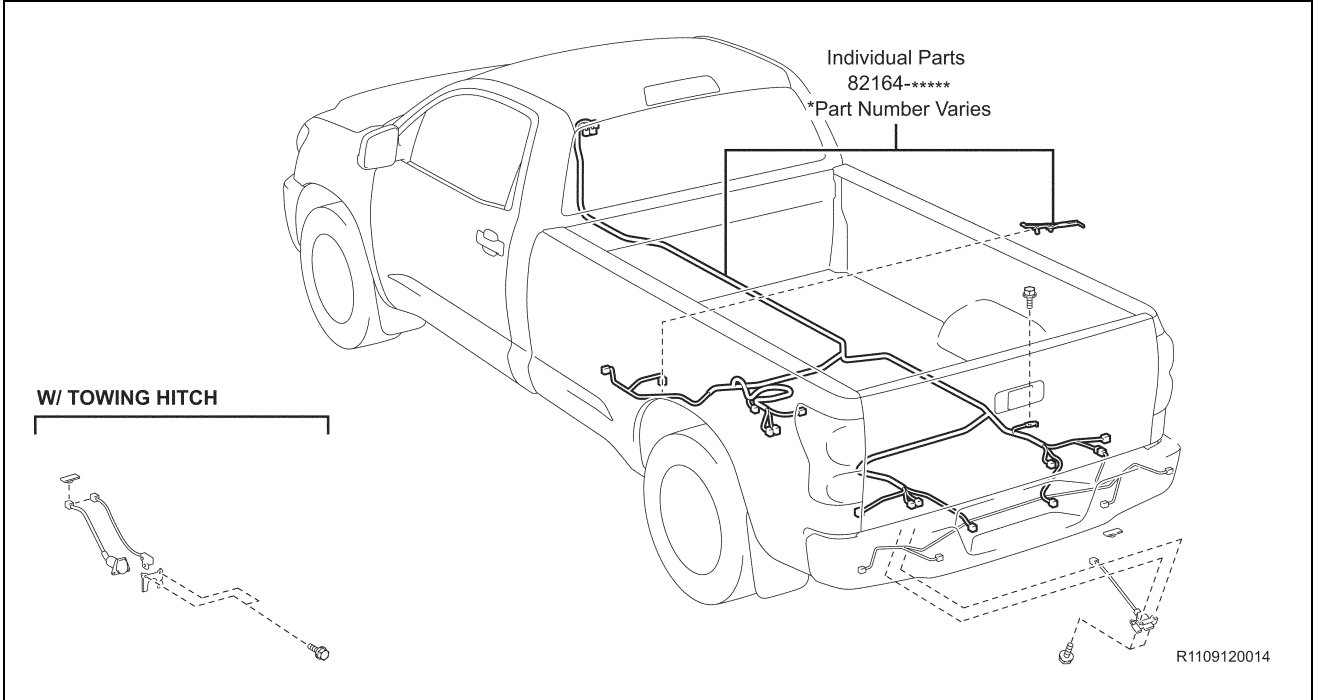

ABS & VSC

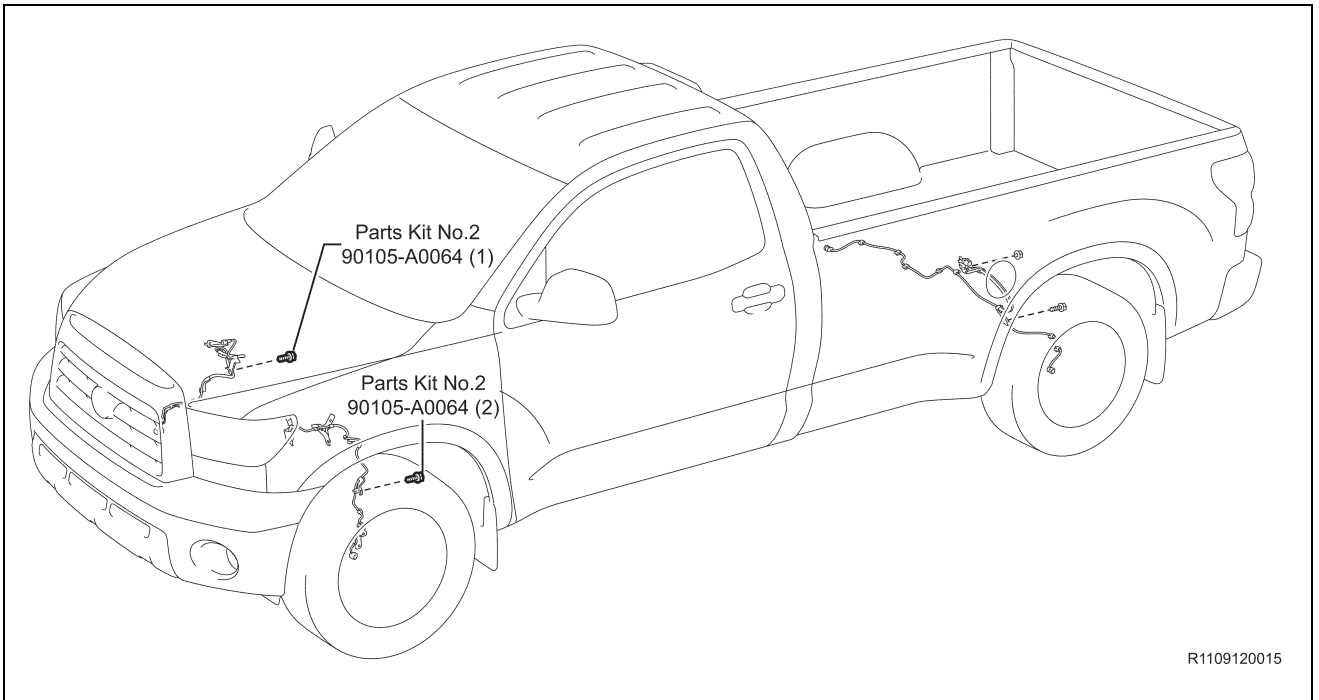

Power Steering

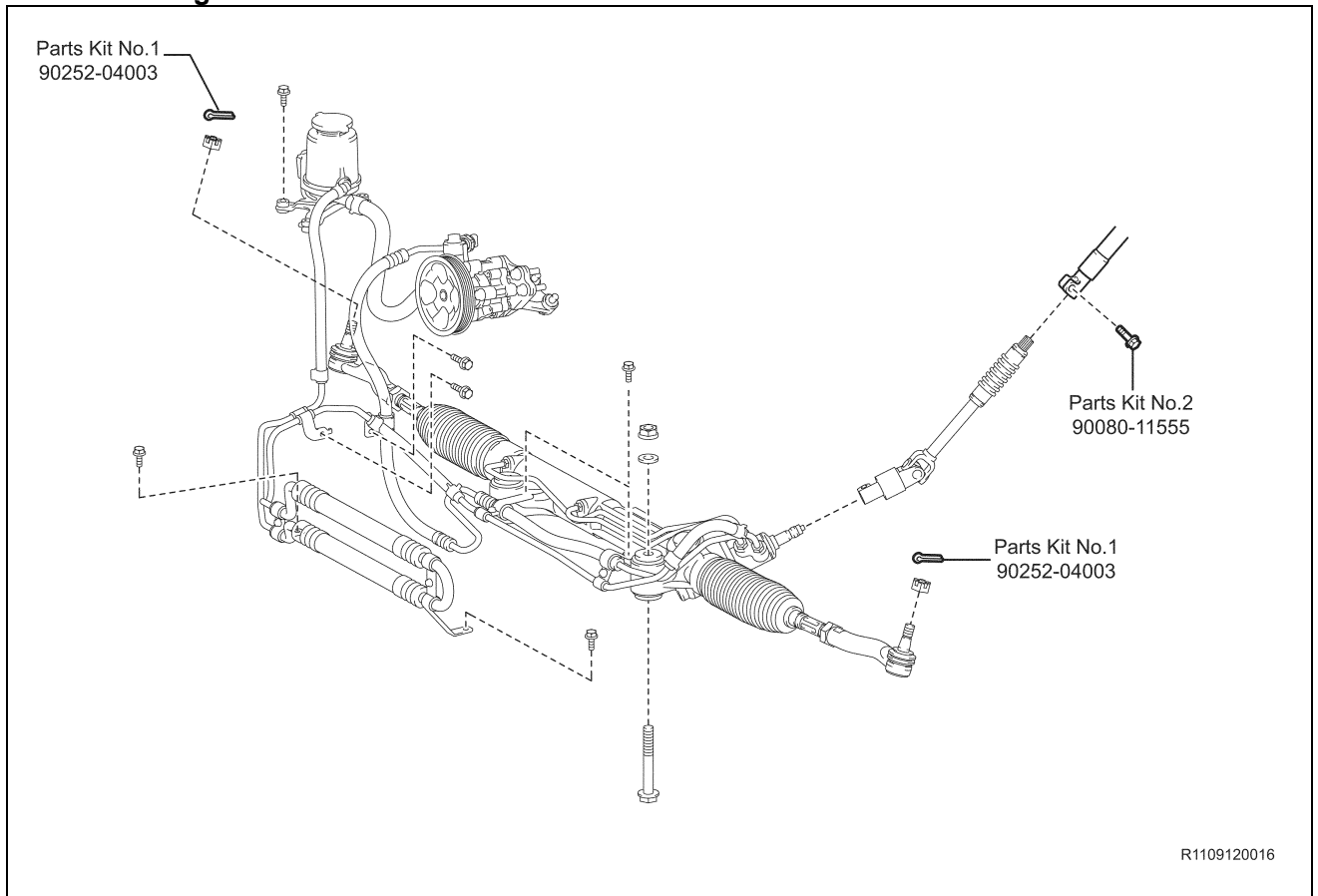

Front Differential

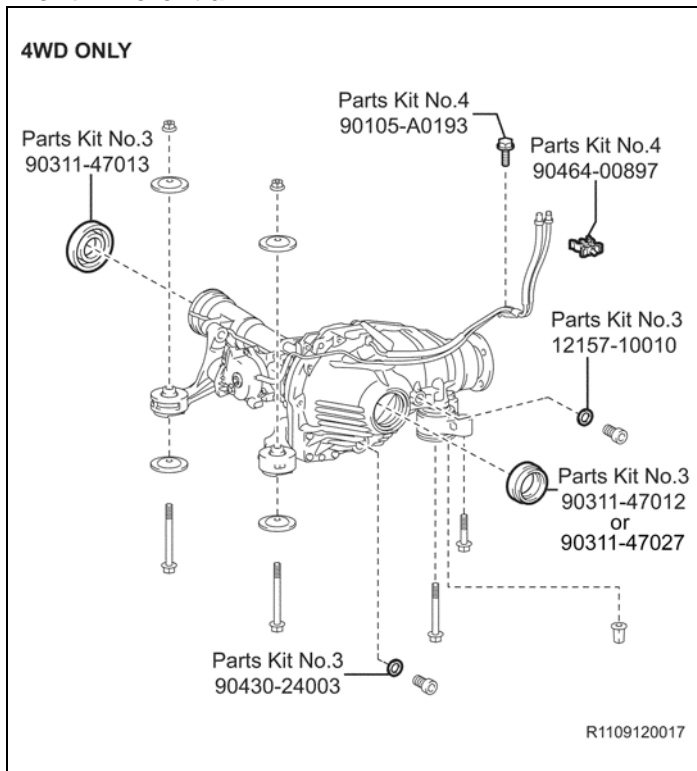

Engine Mounting

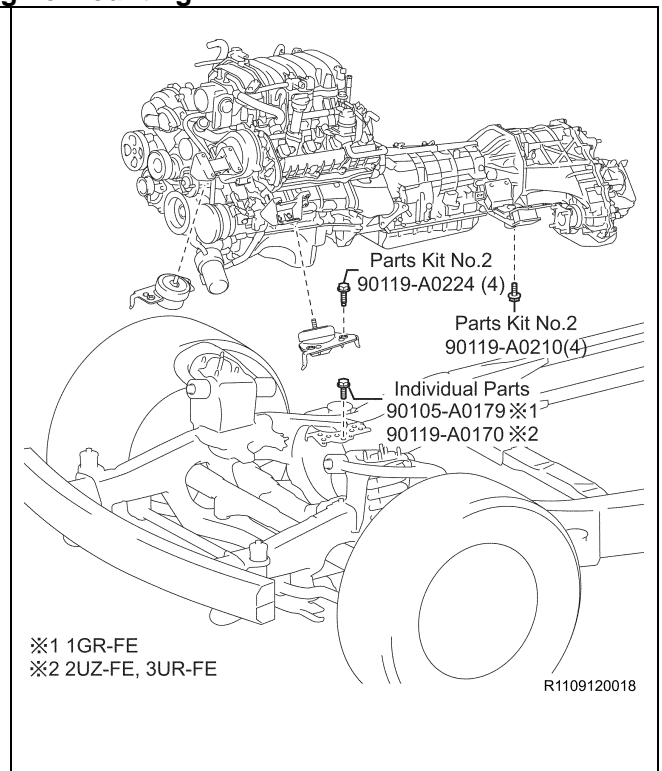

Propeller Shaft

REGULAR CAB 2WD (STANDARD BED)

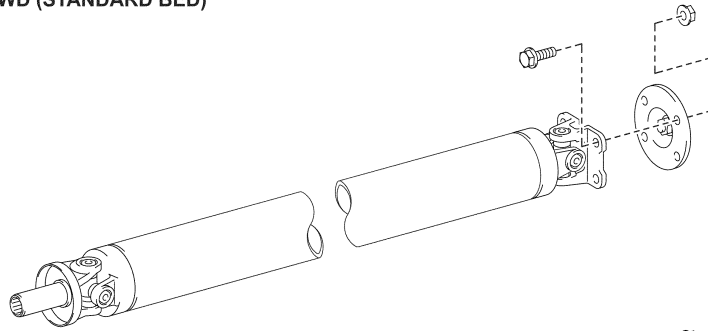

REGULAR CAB 2WD (LONG BED)
DOUBLE CAB 2WD (STANDARD BED)
CREW MAX 2WD

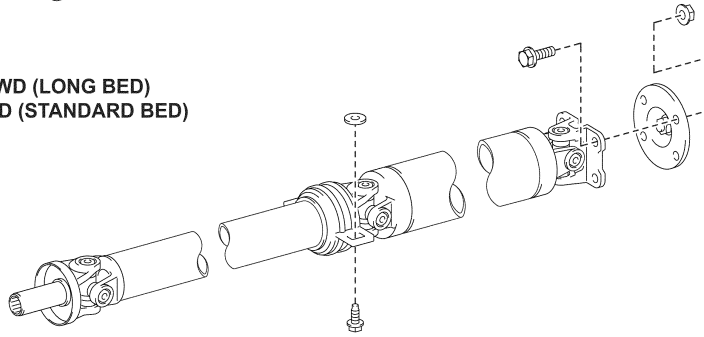

4WD ONLY

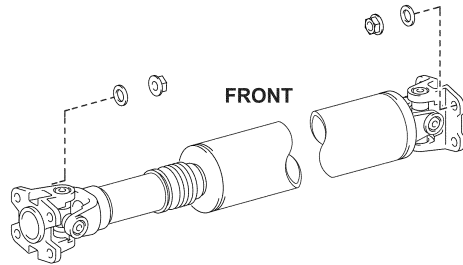

REGULAR CAB 4WD (STANDARD BED)

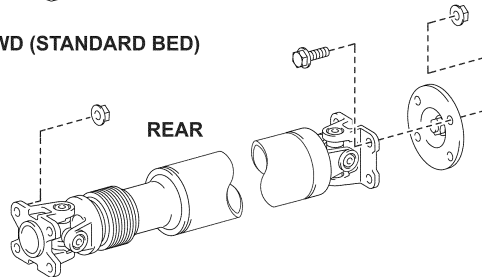

Parts Kit No.4
90119-A0151 (2)

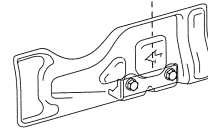

REGULAR CAB 4WD (LONG BED)
DOUBLE CAB 4WD (STANDARD BED)
DOUBLE CAB 4WD (LONG BED)
CREW MAX 4WD

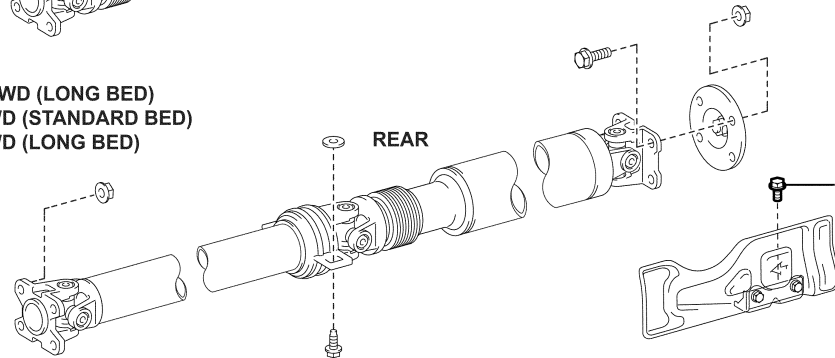

Parts Kit No.4
90119-A0151 (2)

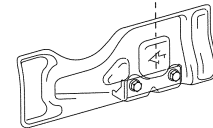

Exhaust System

1GR-FE, 2UZ-FE

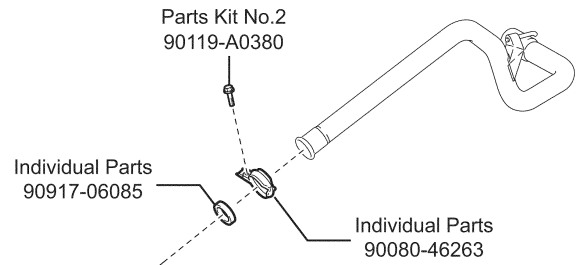
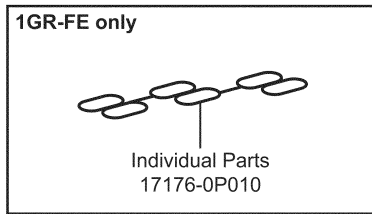

REGULAR CAB (STANDARD BED)

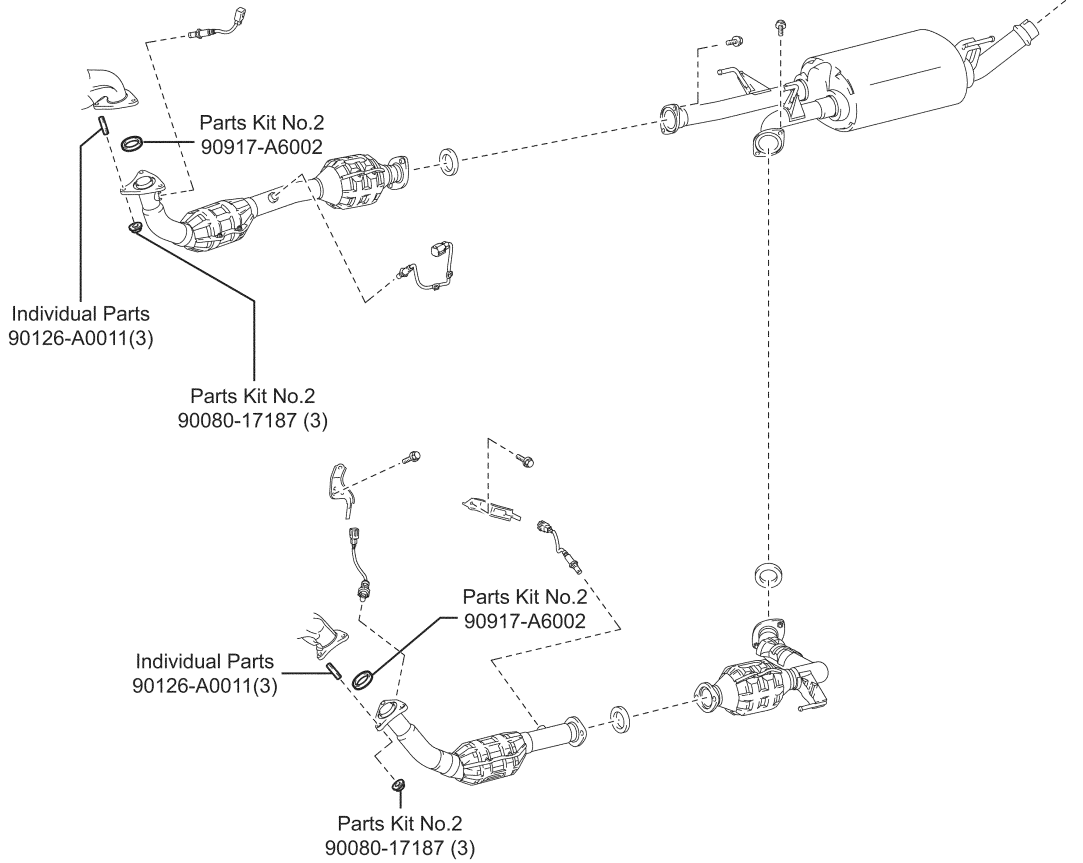

R1109120020

Exhaust System Continued...

1GR-FE, 2UZ-FE

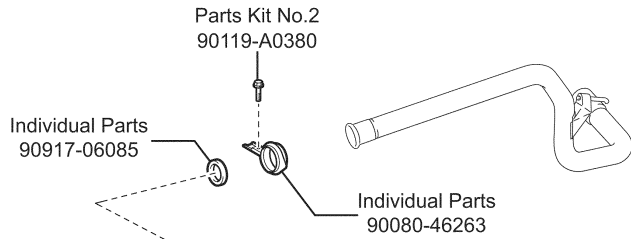
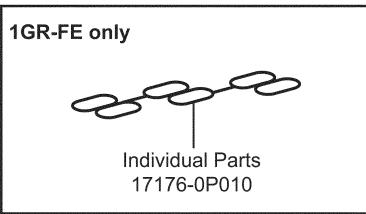

DOUBLE CAB (LONG BED)

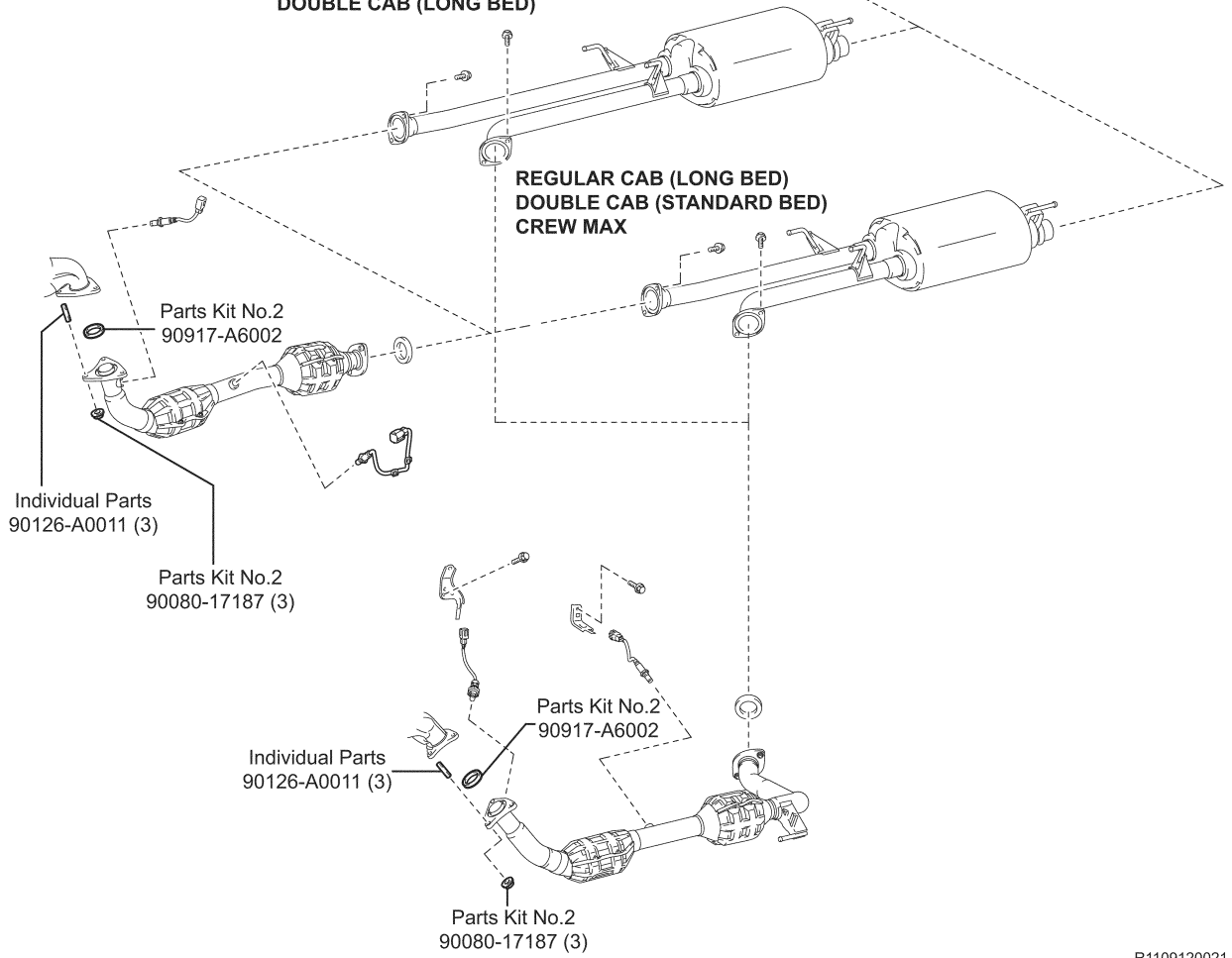

R1109120021

Exhaust System Continued...

3UR-FE

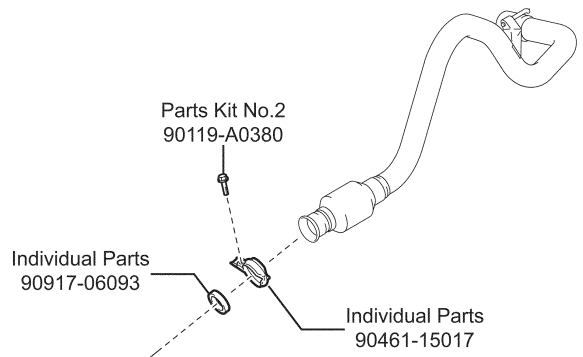

REGULAR CAB (STANDARD BED)

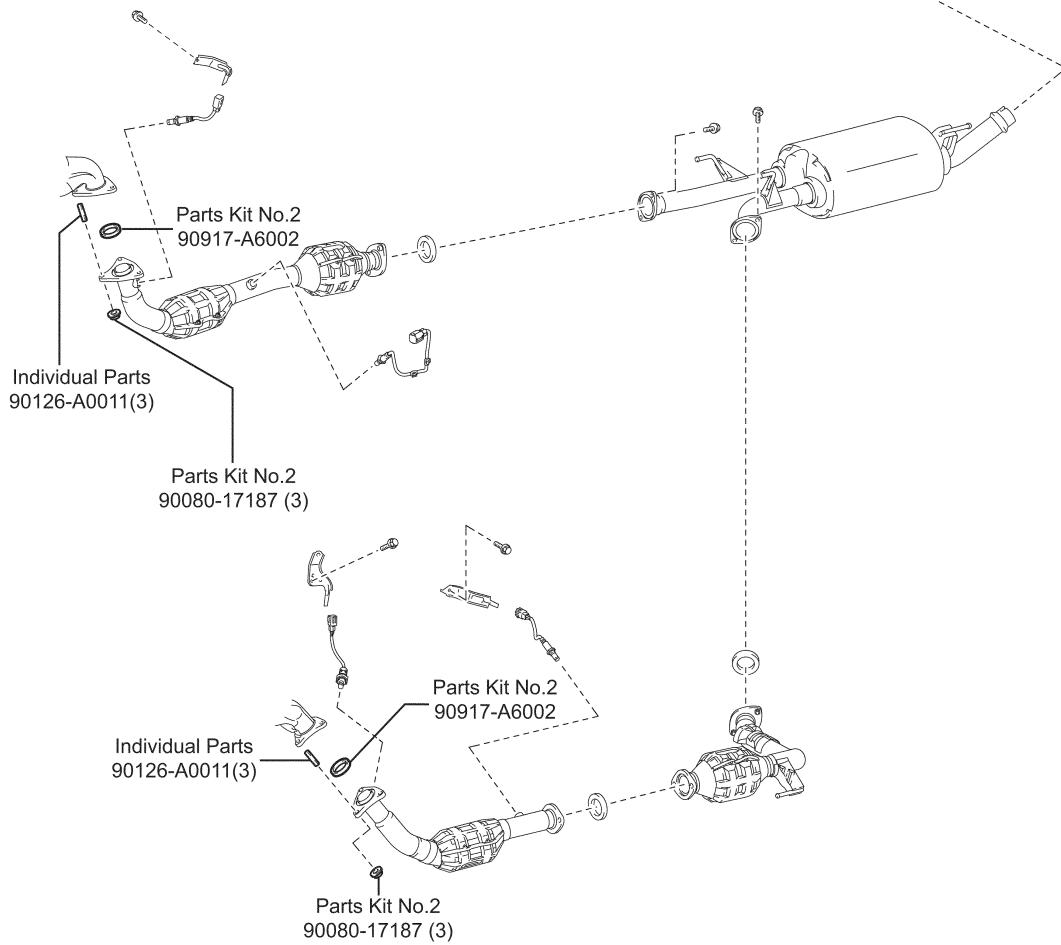

R1109120022

Exhaust System Continued...

3UR-FE

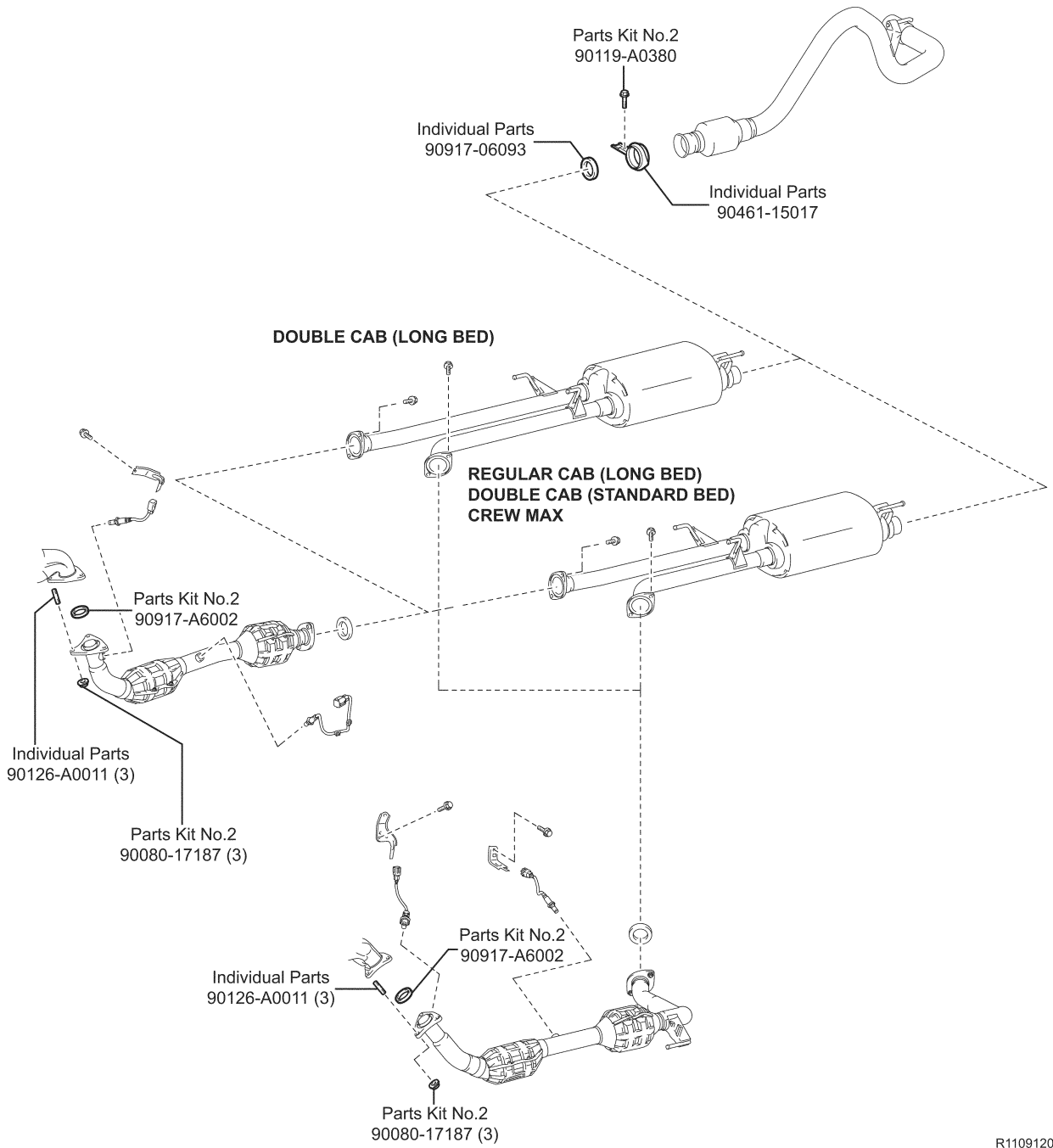

R1109120023

AT Shift Cable

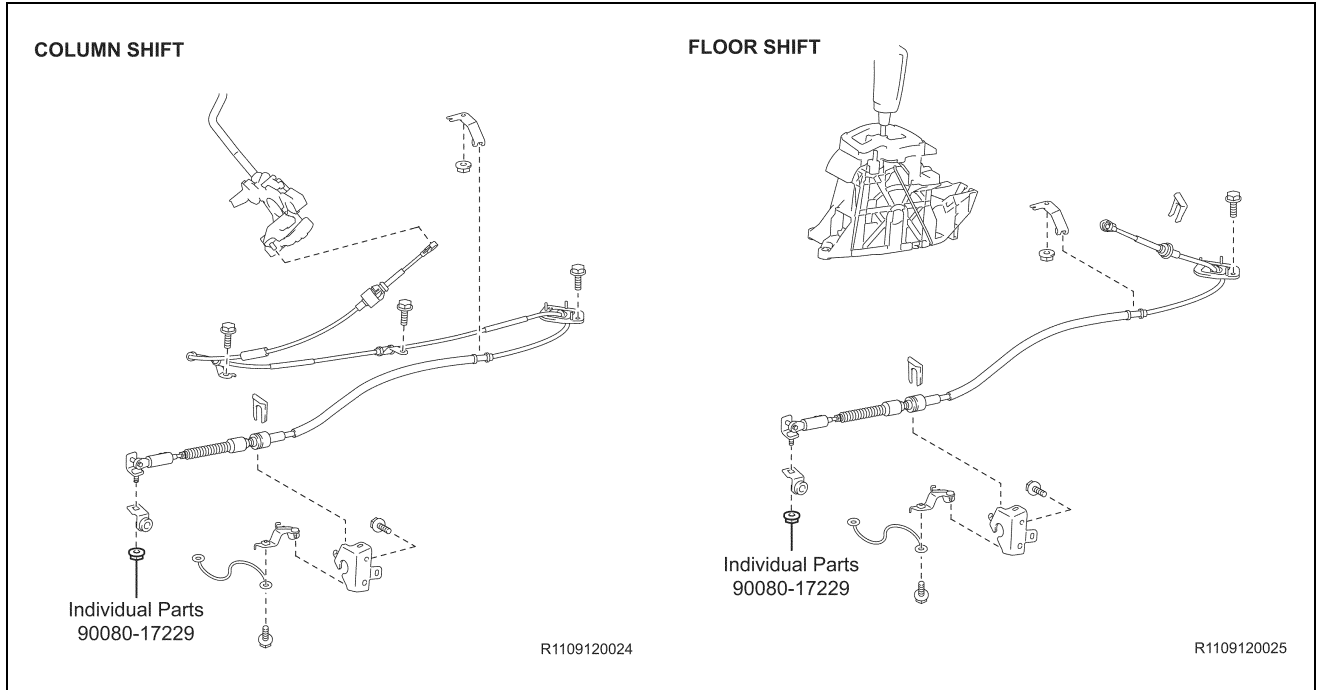

Radiator

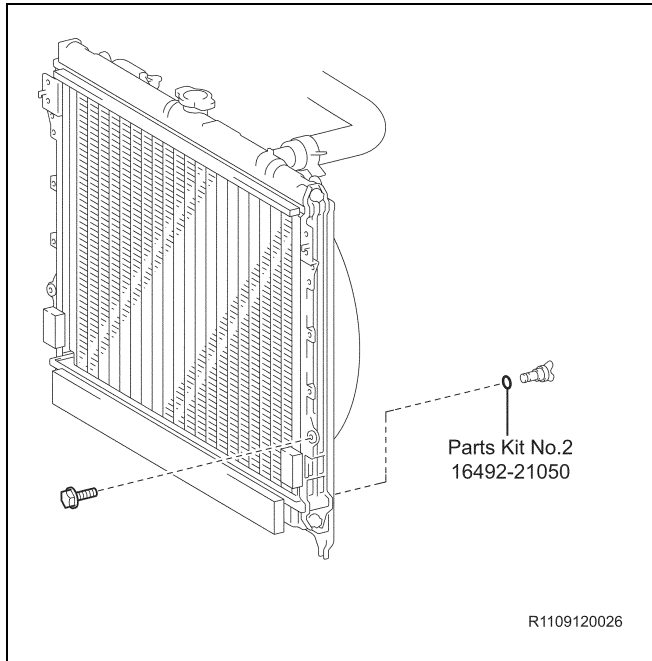

Air Conditioning

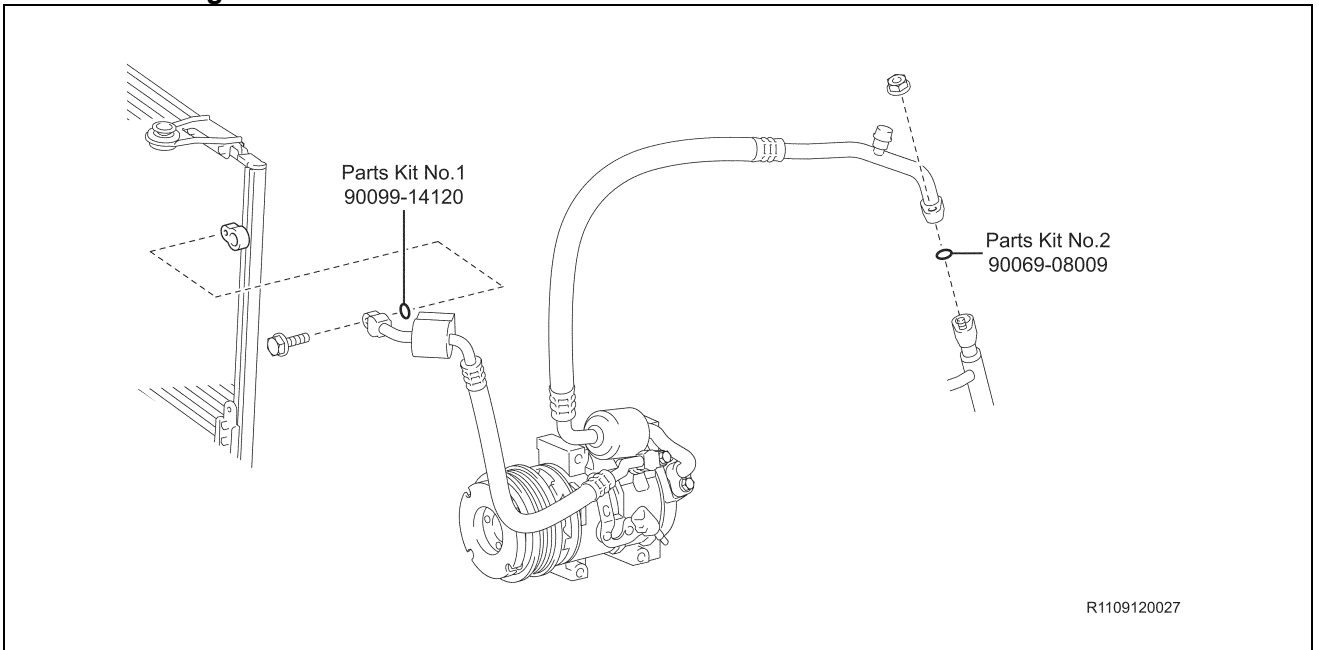

Front Bumper

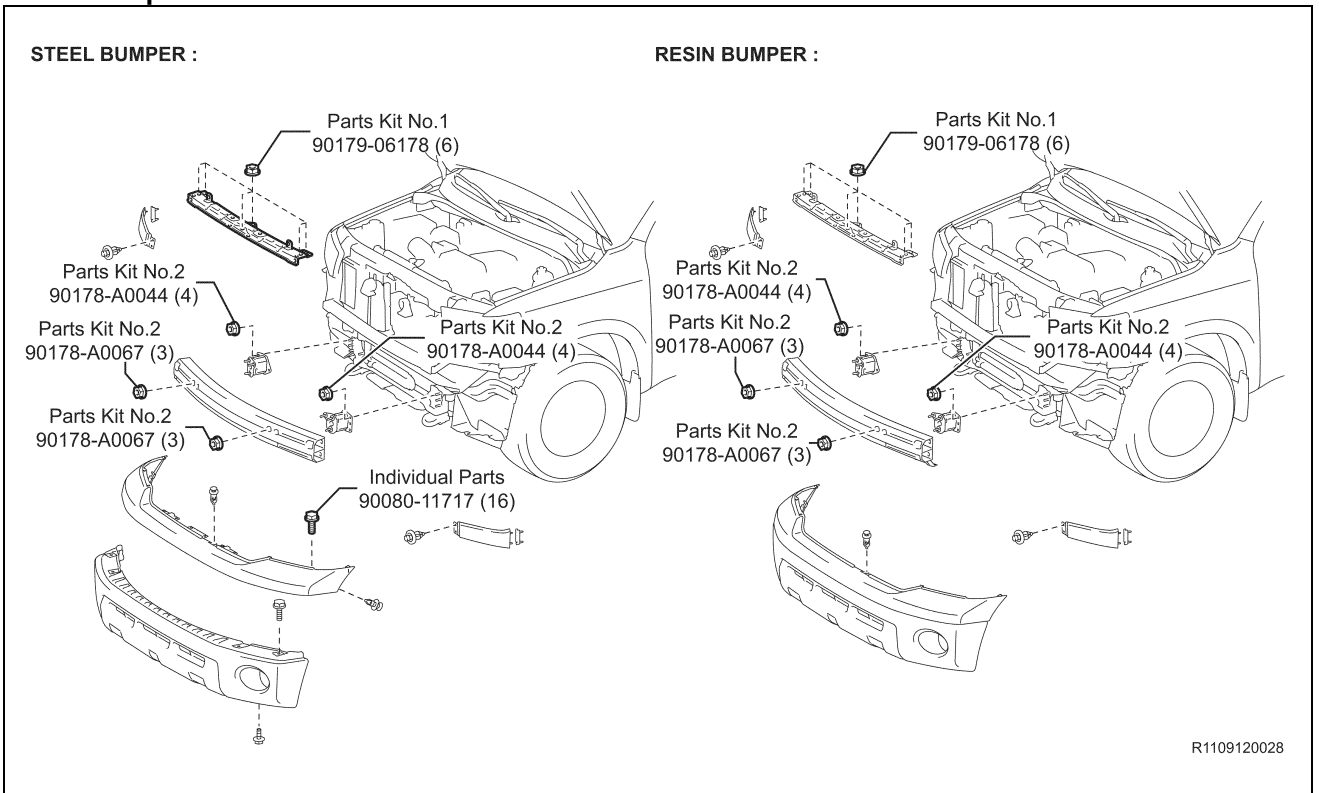

Rear Bumper

STEEL BUMPER :

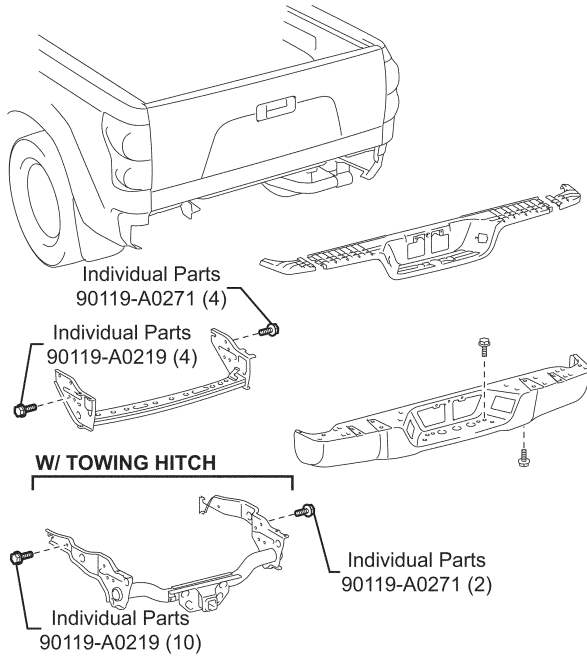

RESIN BUMPER :

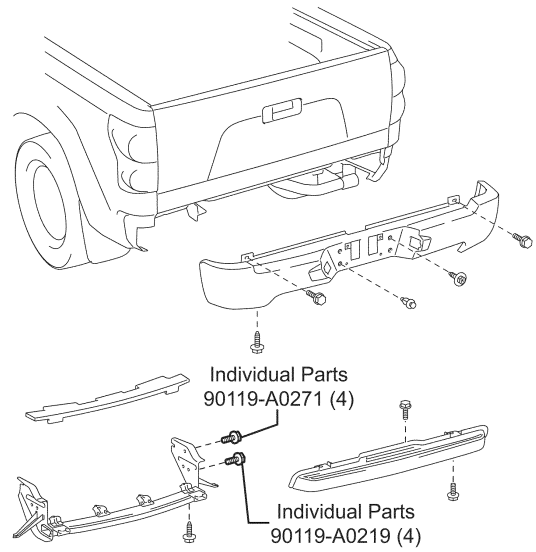

R1109120029

Front Fender

STEEL BUMPER :

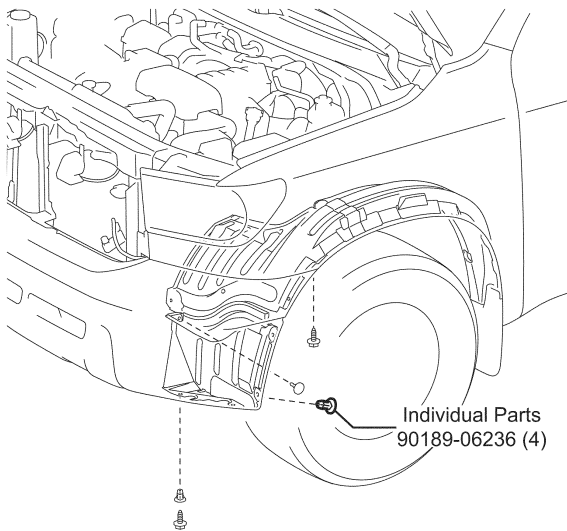

RESIN BUMPER :

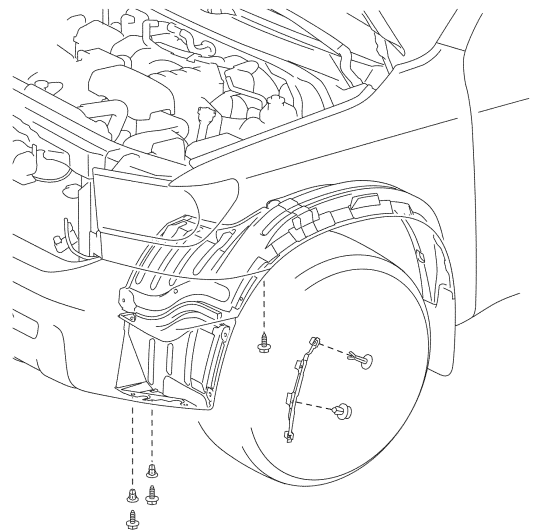

R1109120030

Front Fender Apron

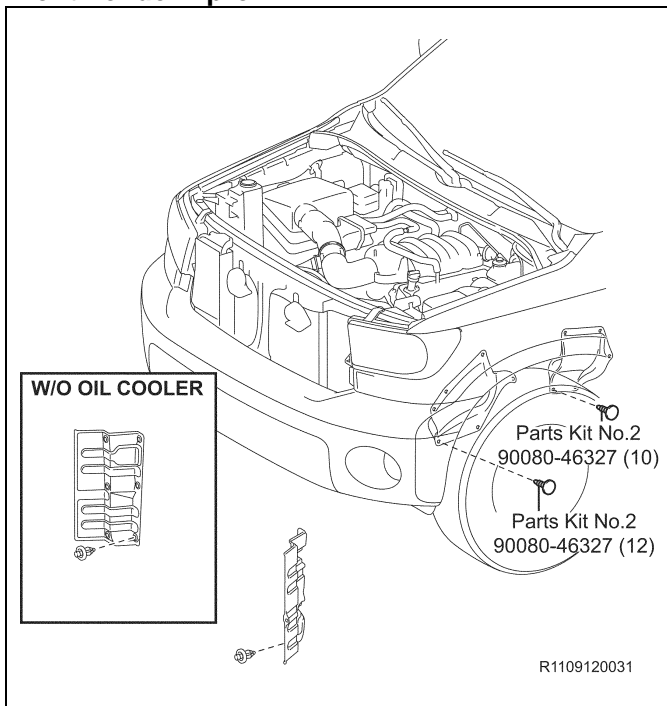

III. FRAME INSPECTION

1. PERFORM INITIAL PRE-HOIST INSPECTION

1. INSPECT THE FRAME FOR EXCESSIVE FRAME CORROSION THAT COULD AFFECT THE STRUCTURAL INTEGRITY OF THE FRAME

2. FRAME INSPECTION



All frame inspection must be performed using the NEW frame inspection application on TIS. Ensure you inspect the frame and properly document the inspection. Failure to perform this will result in denial of the claim.

1. ACCESS INSPECTION APPLICATION

- Run the VIN in TIS and click on the Warranty Tab
- Click on the "Frame Inspection" link on TIS

The screenshot shows the TIS interface for a 2005 Toyota Tacoma. The 'Service Campaign' section is highlighted with a red circle, showing a 'Frame Inspection' link. The page includes a search bar for VIN, vehicle information, and a table of tech cert requirements.

| Maint | Certified | | | | Expert | | | | Master | MDT | Special Courses | Addnl Info |
|-------|-----------|----|----|----|--------|----|----|----|--------|-----|-----------------|--|
| | EG | DT | CH | EL | EG | DT | CH | EL | | | | |
| | | | ✓ | | | | ✓ | | ✓ | ✓ | (SC15A) | Remedy launched for vehicles in Boston, New York, CAT, Cincinnati, Denver, Portland and Chicago regions. |

2. LOG INTO THE INSPECTION APPLICATION

- Reenter your TIS password

The screenshot shows the 'Frame Inspection' login screen. It includes a language selection dropdown (English, French, Spanish), a message to re-enter the TIS password, a 'TIS Password' field, and 'Clear' and 'Login' buttons.

- c. Inspect the frame section and inspect all surfaces of the frame rail and crossmember. Select the photo that best represents the frame condition. If perforation of 10mm or larger is identified select "Peroration of the Frame".

Note: You must click the bubble next to the image to select the condition.

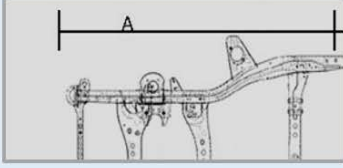





E-Coat Intact



Light to Moderate Surface Rust



Complete Surface Rust with Descaling



Perforation of the Frame

- d. If you selected Perforation of the Frame, the application will request more information about the size of perforation(s) and location.
- e. The section with perforation will split into 2 sub-sections to further identify the perforation location.
- f. Select the size of the perforation in each sub-section.
- g. Upload a photo for each area containing perforation and describe the location in the comments section.

Note:

- If both sub-sections have perforation, it will require two pictures to be uploaded.
- If perforation was accidentally selected use the back button to reselect the correct frame condition.

- h. Select Next to move onto the next section.

Frame Inspection

Select Perforation Identification - NO CRC Applied

The frame section has been split into two smaller sections to help clarify to the technical staff where the perforation is located. Please select the location and size of the perforation and upload an image of the perforation.

Note: If perforation is found in both areas please identify both perforation locations below.

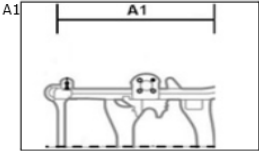
A1 

A1 Check the appropriate perforation size*

Perforation Found during Frame Clearing for CRC- 10mm and above

16mm or above

10 to 15mm

None

Comments: (500 Chars)

IMG_1302.JPG 

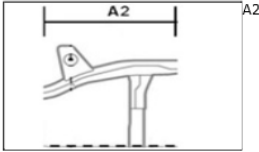
A2 

A2 Check the appropriate perforation size*

Perforation Found during Frame Clearing for CRC- 10mm and above

16mm or above

10 to 15mm

None

Comments: (500 Chars)

- i. Once all sections have been completed, select the Submit button.

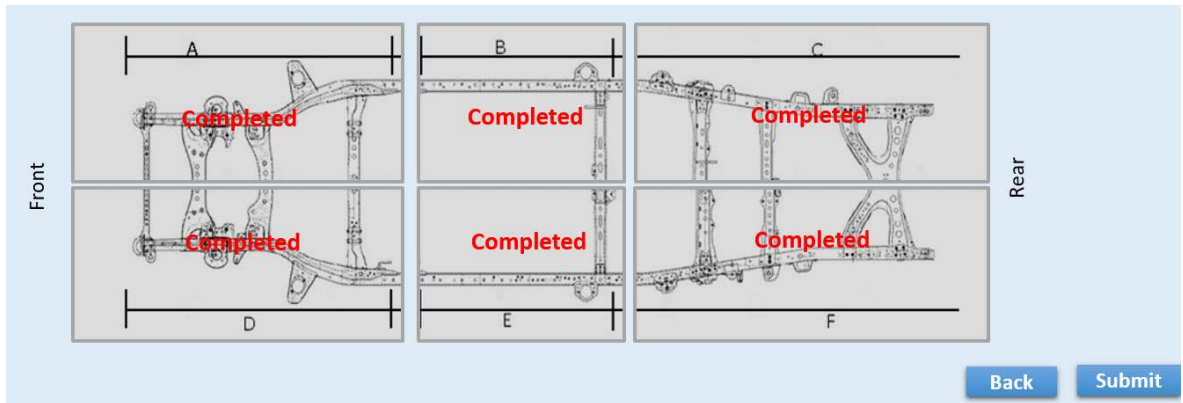

NO Perforation Found

- j. If no perforation was not found, follow the directions as provided.

Frame Inspection Case: FI000000001
Inspection Summary: No Perforation Found

The frame inspection has been completed successfully. Please print a copy of the inspection case and file it with the R.O. for warranty claim filing.

Perforation Found

- k. If perforation was found, this application will be submitted to your Regional Office for review. The region office will review the inspection and provide feedback if the frame replacement is approved for future repair.



DO NOT proceed with frame replacement or parts ordering until you are provided with approval from the Regional Office. Approval will be sent to the TIS inbox for the inspection, Service Manager and Parts Manager.



Frame Inspection

Frame Inspection - NO CRC Applied

| | | | |
|------------------------|--------------------------|---------------------------------|----------------------------|
| User ID | : JOHNSOJ459 | Technician Name | : James Johnson |
| Dealer Code | : 54012 | Dealer Name | : CYPRESS COLLEGE |
| Date/Time | : 07/08/2017 2:12 PM PDT | VIN | : 5TBRT38101S125908 |
| Vehicle Mileage | :* 120568 Miles | DMY | : TOYOTA Tundra 2001 |
| | | Vehicle Registered State | :* VT <input type="text"/> |

Frame Inspection Case: FI0000000881
Inspection Summary: Perforation has been found in Sections A1,C1,C2.
Toyota Technical Staff will review and provide feedback or authorization for repair.
Feedback and authorization will be sent to your TIS Inbox when the review has been completed.

Close

IV. FRAME REPLACEMENT WORK PROCEDURE

A. PERFORM PRELIMINARY VEHICLE INSPECTION

1. Perform health check and record any preexisting DTCs
2. Test drive the vehicle and inspect the following vehicle functions/current operating conditions prior to vehicle repair.
 - 4WD System (*4WD Only*)
 - Interior Lights
 - Exterior Lights
 - HVAC System
 - Audio System
 - Power Windows
 - Power Door Locks
 - All Gauges, Indicators and Warning Lights
 - Cooling Fans
 - Etc.
3. Documents the current vehicle operating condition on the [Frame Replacement Inspection Sheet](#).

B. SAFETY CHECKLIST & PRECAUTIONS WHEN DRAINING THE FUEL SYSTEM



- Always remember **“SAFETY FIRST”**.
- Be extremely careful when handling fuel to prevent fires from occurring.
- Before beginning work on the fuel system, perform the following safety check list.
- Before removing any fuel system part, drain all fuel to prevent spilling.

1. AIR VENTILATION

- Perform work in a well-ventilated area.
- DO NOT** work underground or in an area where fuel vapors may fill the room due to poor ventilation.
- Quickly clean up any spilled fuel with a dry cloth and dissipate the fuel vapors.
- Dry all cloths that have come in contact with fuel in a well-ventilated area and dispose of them properly (according to applicable local regulations).

2. FIRES AND IGNITION SOURCES ARE STRICTLY PROHIBITED

- Fires and ignition sources are prohibited while working on the fuel system.
- Clearly display the sign found on the next page stating **“WORKING WITH GASOLINE, NO FIRES OR IGNITION SOURCES”**.
- Smoking is prohibited near the work area.
- DO NOT** work in areas where there are welders, grinders, drills, electric motors, heaters, etc.
- DO NOT** use work lamps or any other electrical appliance due to the risk of sparks flying from the power switch or a rise in temperature.
- DO NOT** use metal hammers while working, due to the risk of flying sparks.
- DO NOT** start any engines or perform any of the above in neighboring work bays.

3. FIRE EXTINGUISHER

- Have a fire extinguisher ready and available before beginning work.

4. PREVENT STATIC ELECTRICITY

- To help prevent static electricity, lightly wet the floor with water, but not to the point where it creates a hazardous working condition.
- Place appropriate warning cones or stand signs around the area as a caution.

5. PRECAUTIONS WHEN USING A LIFT

- For bays equipped with auto lifts, cover all access cover joints with duct tape.
- In the event that fuel has leaked inside the auto lift, remove the access cover and clean up any spilled fuel. Dissipate fuel vapors until the smell is gone.

6. PREVENT THE FUEL FROM SPRAYING

- When disconnecting any fuel tubes, pipes, hoses or connectors there may still be some pressure remaining, even after discharging the system. To prevent the fuel from spraying, cover the tubes, pipes or connectors with a shop rag before disconnecting.
- Remember to always wear protective goggles especially when disconnecting fuel tubes, pipes, hoses or connectors.

7. PREVENT THE FUEL FROM CONTACTING OTHER PARTS

- Do not allow the fuel to come in contact with any parts made of rubber or leather.

8. ASSIGN A SAFETY SUPERVISOR

- Assign a safety supervisor to be in charge of all safety precautions and fire hazards around the work area.

■ Copy And Display When Working

**WORKING WITH
GASOLINE**

**NO FIRES
NO IGNITION
SOURCES**

Supervisor

■ Copiar y exhibir al trabajar

**TRABAJANDO CON
GASOLINA**

NINGÚN INCENDIOS

**NINGUNA FUENTE
DE IGNICIÓN**

Supervisor

C. REMOVE THE REAR BED ASSY



- If the frame is perforated, **ONLY** raise the vehicle high enough to remove the tires.
- For added safety and support place jack stands under the front and rear portions of the frame.
- **DO NOT** work directly underneath the vehicle when performing bed assy removal.
- The actual vehicle specs, equipment and parts required may differ than what is shown. Please use the correct specifications and parts for the model you are working on.
- For additional repair information, please reference to the appropriate repair manual found on TIS for the vehicle you are working on.

1. CENTER THE VEHICLE BETWEEN THE LIFT ARMS

- a) Verify the vehicle is aligned with the center point of the lift to prevent interference and damage to the frame and/or lift.

2. REMOVE THE FOLLOWING PARTS

- License Plate Light Assy LH/RH
- No.3 Frame Wire
- Rear Quarter Panel Mudguard LH/RH (*If Equipped*)
- Rear Bumper Assy
- Side Step Assy LH/RH (*If Equipped*)

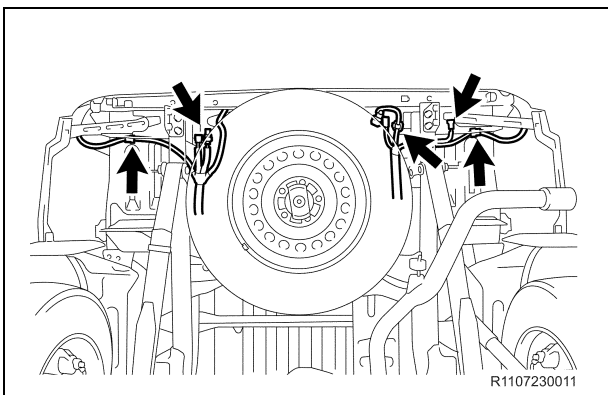

3. DISCONNECT THE FRAME WIRE HARNESS

- a) Disconnect the clamps, connectors and the frame wire harness from the bed assy.

NOTE:

- The number of connectors may differ depending on the vehicle specification.
- Be careful not to damage the wire harness clamps when removing them.

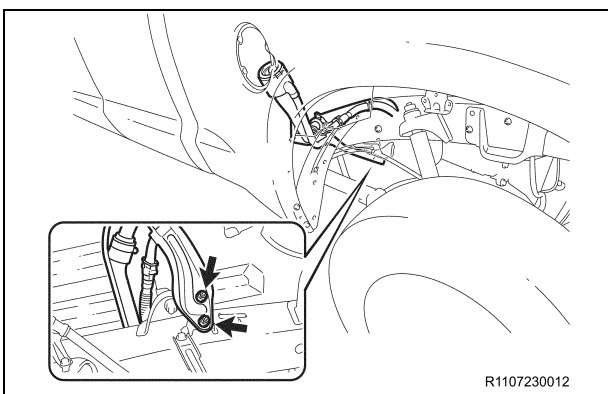

4. DISCONNECT THE FUEL TANK INLET PIPE SUB-ASSY

- a) Remove the 2 nuts and disconnect the fuel tank inlet pipe sub assy.

Long Bed :

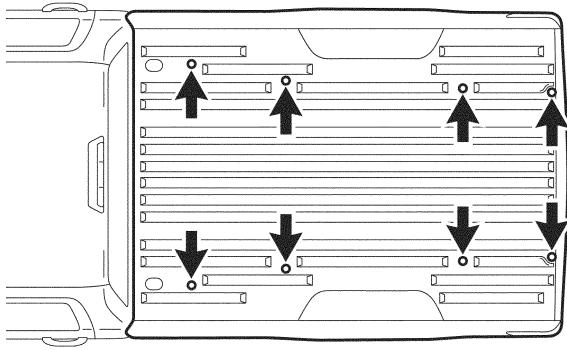

Standard Bed and Crewmax (Short Bed) :

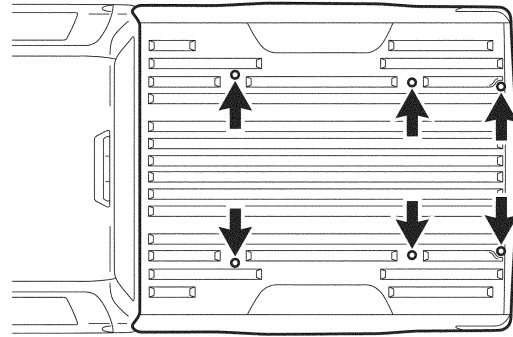

R0906160004E02

5. REMOVE THE REAR BED ASSY

- a) Using a Torx® T55H Tamper Resistant Socket, remove the Torx® bolts from the rear bed assy.
- Long Bed: 8 Torx® bolts
 - Standard Bed and Crewmax (Short Bed): 6 Torx® bolts

NOTE:

- Use 4 or more people to remove the rear bed assy from the frame.
- Evenly support the rear bed assy when removing it.

D. DISCHARGE THE FUEL SYSTEM PRESSURE



- **DO NOT** disconnect any part of the fuel system until you have discharged the fuel system pressure.
- Even after discharging the fuel system pressure, place a piece of cloth around the tubes, pipe, hoses and connectors as you separate them to reduce the risk of fuel spraying on yourself, in the engine compartment and onto other parts.
- For additional repair information, please reference to the appropriate repair manual in TIS for the vehicle you are working on.

1. CHECK FOR DTCs
2. RECORD THE RADIO STATION PRESETS
3. DISCONNECT THE NEGATIVE (-) BATTERY TERMINAL

NOTE:

Wait 90 seconds after the negative (-) terminal cable is disconnected from the battery before proceeding. Doing so will prevent the SRS from being deployed (i.e. airbag, seat belt pretensioner, etc.).

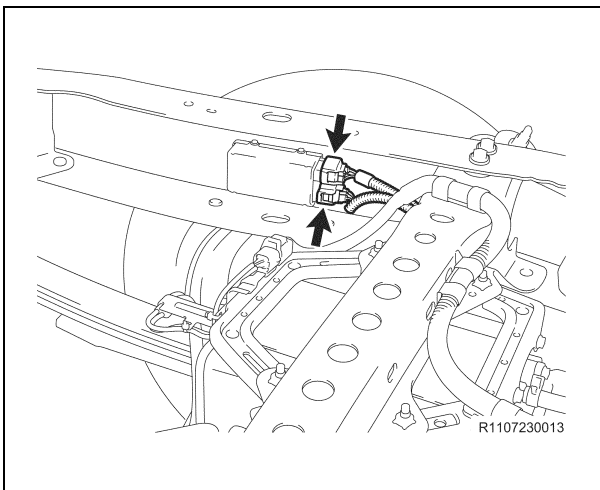

4. DISCHARGE THE FUEL SYSTEM PRESSURE

- a) Disconnect the 2 fuel pump ECU connectors.
- b) Reconnect the cable to the negative (-) battery terminal.
- c) Start the engine.
- d) After the engine has stopped, turn the ignition switch OFF.
- e) Crank the engine again to check that it does not start.
- f) Disconnect the negative (-) battery terminal.

NOTE:

Please make sure to follow the procedure listed above. This will prevent a large amount of gasoline from spilling out when high pressure fuel tube is disconnected.

E. REMOVE THE CAB BODY ASSY



- If the frame is perforated, **ONLY** raise the vehicle high enough to remove the tires.
- For added safety and support place jack stands under the front and rear portions of the frame.
- **DO NOT** work directly underneath the vehicle when performing cab body assy removal, unless noted.
- The actual vehicle specs, equipment and parts required may differ than what is shown. Please use the correct specs and parts for the model you are working on.
- For additional repair information, please reference to the appropriate repair manual in TIS for the vehicle you are working on.

1. REMOVE THE ENGINE UNDER COVER No.1

NOTE:

Use precaution when performing this step, as you will need to work underneath the vehicle.

2. EVACUATE THE REFRIGERANT FROM THE AIR CONDITIONING SYSTEM

3. DRAIN THE FOLLOWING FLUIDS

- Coolant
- Brake Fluid
- Front Differential Fluid

NOTE:

DO NOT remove the radiator cap while the radiator and engine are hot, doing so may cause the coolant to spray out causing potential injuries.

4. REMOVE THE FOLLOWING PARTS

- Front Door Scuff Plate LH/RH
- Cowl Side Trim Board LH/RH
- No.2 Dash Panel Insulator Pad
- No.3 Dash Panel Insulator Pad
- Jack and Tool (Standard Tool)
- No.1 w/ Box Speaker Assy (*If Equipped*)
- Luggage Compartment Box LH (*Regular Cab Only*)
- Upper Back Panel Garnish (*Regular Cab Only*)
- Front Seat Outer Belt Assy LH (*Regular Cab Only*)
- Lower LH Quarter Trim Panel Assy (*Regular Cab Only*)
- Lift up the second seat and pull up the rear edge of the Floor Carpet (*Double Cab Only*)
- Back Panel Trim LH/RH (*Crewmax Only*)

5. REMOVE THE FOLLOWING PARTS

- Front Wheels
- Front End Panel LH/RH
- Front Fender Splash Shield Sub-Assy LH/RH
- Front Bumper Assy
- Front Bumper Reinforcement Sub-Assy
- No.2 Front Bumper Extension Sub-Assy LH/RH
- Front Fender Mudguard LH/RH (*If Equipped*)
- Throttle Body Cover Sub- Assy (*2UZ-FE Only*)
- V-Bank Cover Sub- Assy (*1GR-FE, 3UR-FE Only*)
- Air Cleaner Hose and Air Cleaner Assy

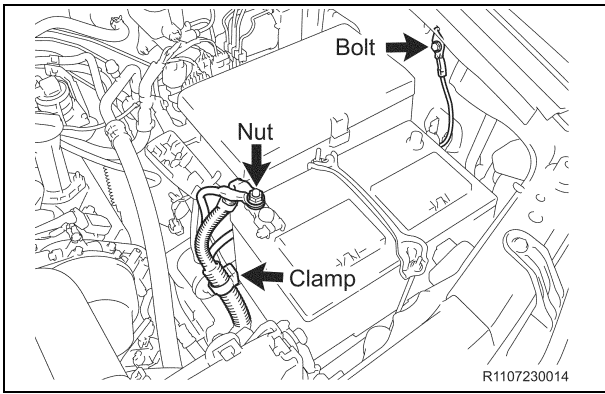

6. DISCONNECT THE ENGINE WIRE HARNESS (LH SIDE)

- a) Remove the nut and disconnect the 2 (+) positive battery cables.
- b) Remove the bolt and disconnect the ground wire.
- c) Disconnect the clamp.

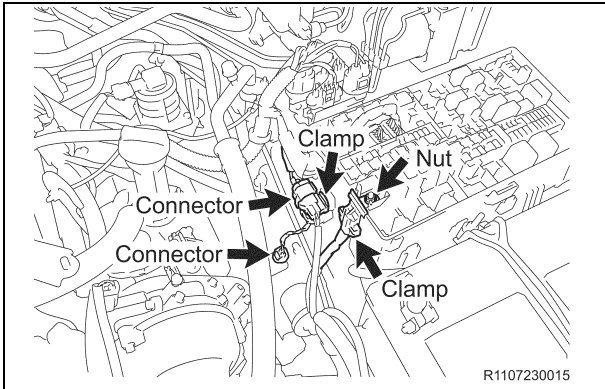

- d) Remove the No.1 relay block cover.
- e) Disconnect the 2 connectors and clamps.
- f) Remove the nut and disconnect the (+) positive battery cable.

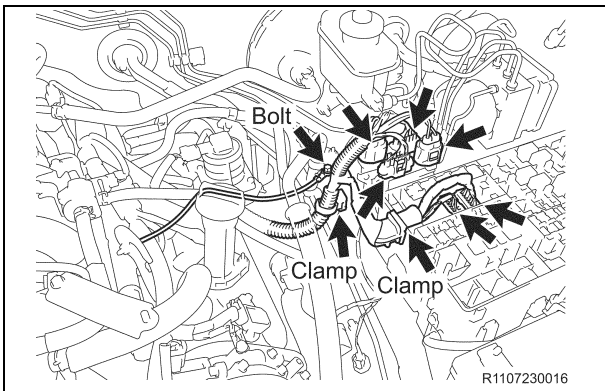

- g) Disconnect the 6 connectors and 2 clamps.
- h) Remove the bolt and disconnect the ground wire.

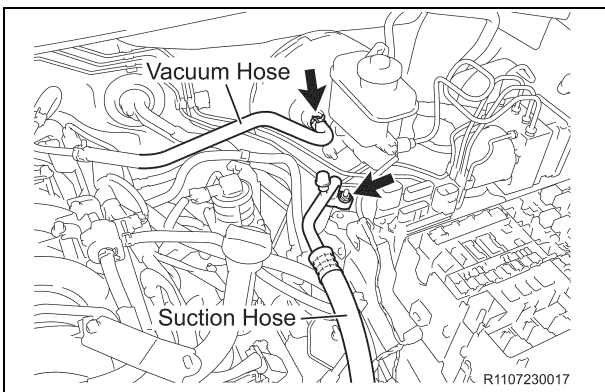

7. DISCONNECT THE No.1 COOLER REFRIGERANT SUCTION HOSE ASSY

- a) Remove the nut and disconnect the suction hose.

8. DISCONNECT THE VACUUM HOSE ASSY

- a) Disconnect the vacuum hose.

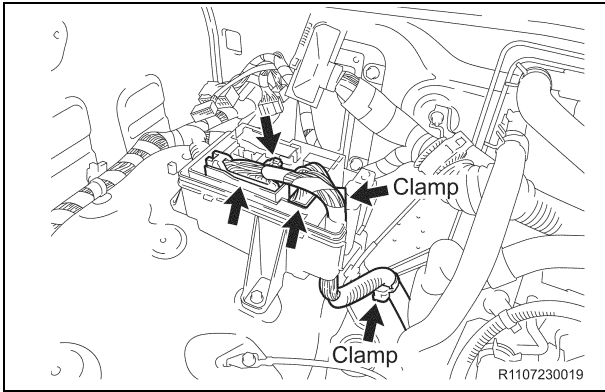

9. DISCONNECT THE ENGINE WIRE HARNESS (RH SIDE)

- a) Disconnect the 3 connectors and 2 clamps.
- b) Disconnect the 5 connectors and 2 clamps.

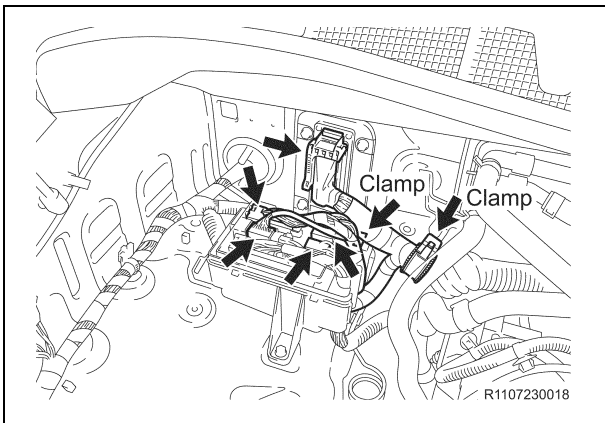

- c) Remove the connector holder block cover upper.

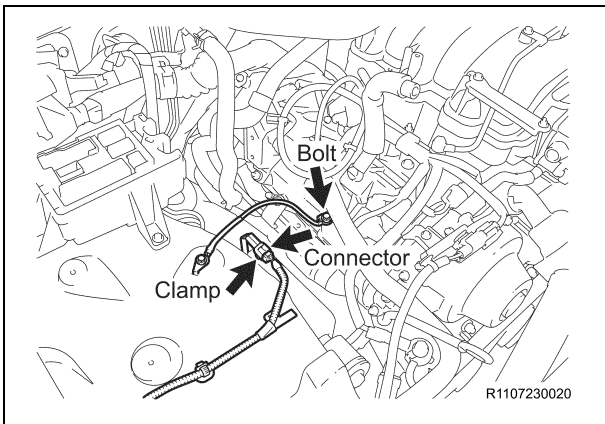

- d) Disconnect the skid control sensor connector and clamp.

NOTE:
Disconnect the clamp of the sensor completely from the Body.

- e) Remove the bolt and disconnect the ground wire.

NOTE:
Disconnect on the engine side otherwise the bolt may be broken.

10. DISCONNECT THE INLET HEATER HOSE AND OUTLET HEATER HOSE, ENGINE SIDE

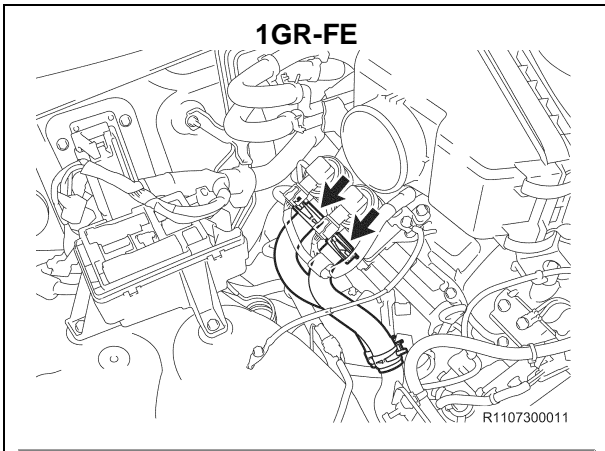

11. DISCONNECT THE AIR INJECTION SYSTEM HOSES

- a) Disconnect the No.5 hose and No.4 hose. (**1GR-FE**)
- b) Disconnect the No.2 hose and clamp. (**2UZ-FE**)
- c) Disconnect the clamp, No.2 hose and No.3 hose. (**3UR-FE**)

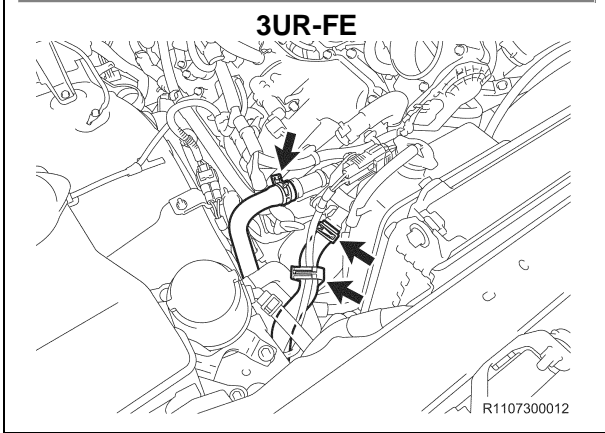
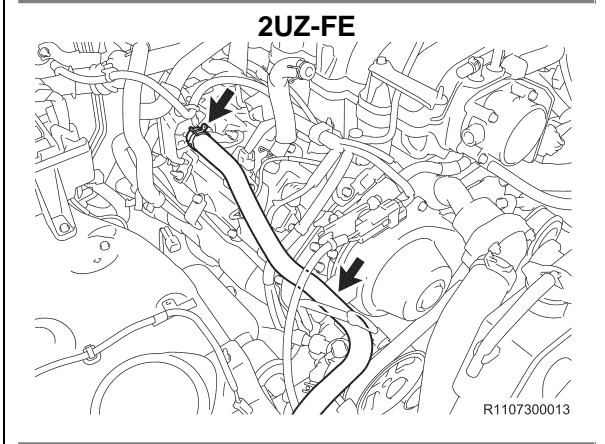

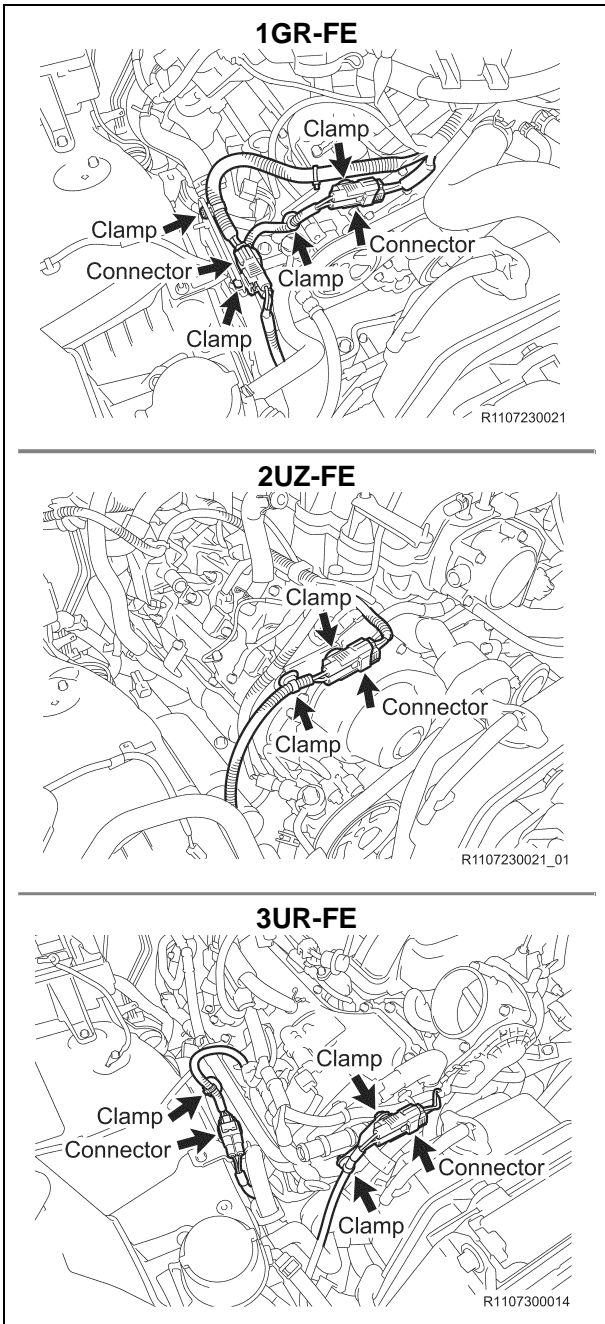

12. DISCONNECT THE AIR PUMP HARNESS

- Disconnect the 2 connectors and 4 clamps. **(1GR-FE)**
- Disconnect the connector and 2 clamps. **(2UZ-FE)**
- Disconnect the 2 connectors and 3 clamps. **(3UR-FE)**

13. REMOVE THE FOLLOWING PARTS

- Upper Center Front Bumper Retainer **(Air Oil Cooler Equipped Vehicles Only)**
- Oil Cooler Assy **(Air Oil Cooler Equipped Vehicles Only)**
- Radiator Side Deflector LH
- Radiator Side Deflector RH **(If Equipped)**

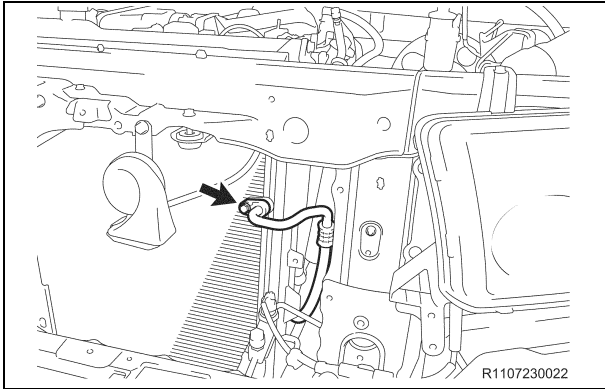

14. DISCONNECT THE No.1 COOLER REFRIGERANT DISCHARGE HOSE

- a) Remove the bolt and disconnect the discharge hose.

15. REMOVE THE FOLLOWING PARTS

- Radiator Inlet Hose
- Radiator Outlet Hose
- Radiator Fan
- Fan Shroud
- Radiator Assy

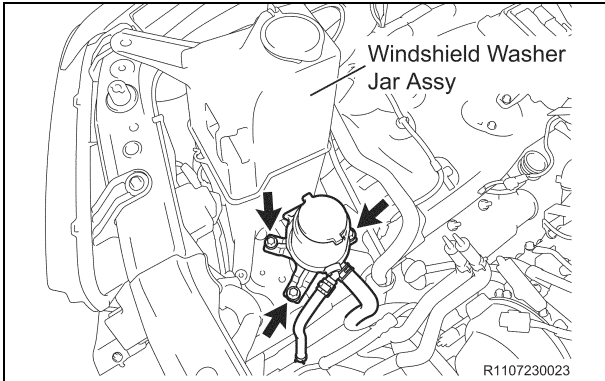

16. DISCONNECT THE VANE PUMP OIL RESERVOIR ASSY

- a) Remove the 3 bolts of the windshield washer jar assy to make space for removal of the bolt.
- b) Remove the 3 bolts and disconnect the vane pump oil reservoir assy.

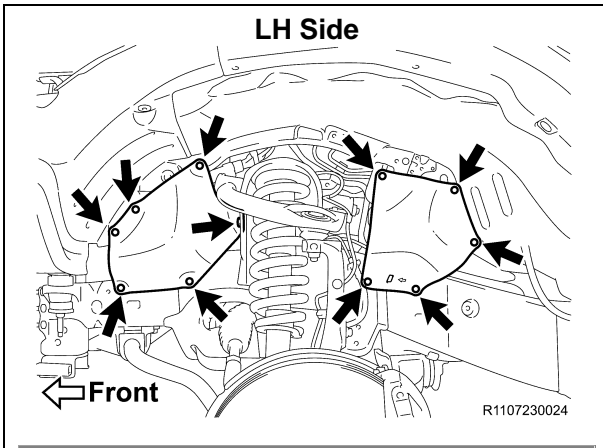

17. REMOVE THE FRONT FENDER APRON SEALS

- a) Remove the left side 11 clips and front fender apron seal LH/RH.
- b) Remove the right side 11 clips and front fender apron seal LH/RH.

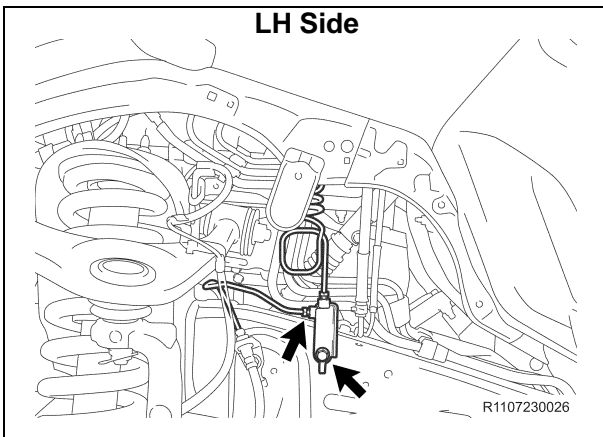
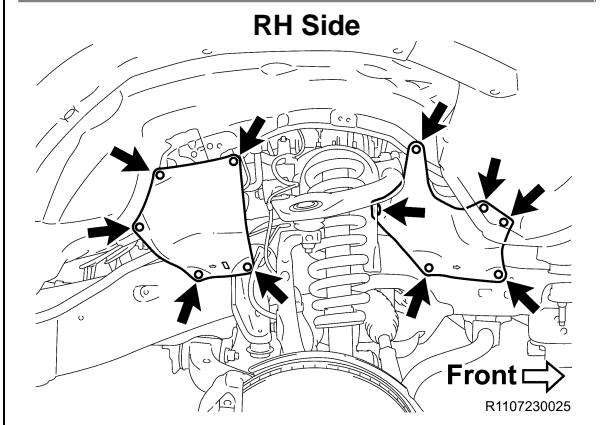

18. DISCONNECT THE FRONT BRAKE TUBES

- a) Disconnect the front brake tube and remove the bolt.
- b) Repeat the procedure on the opposite side.

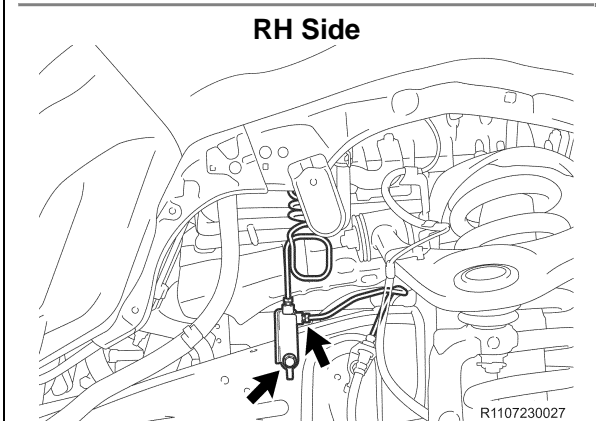

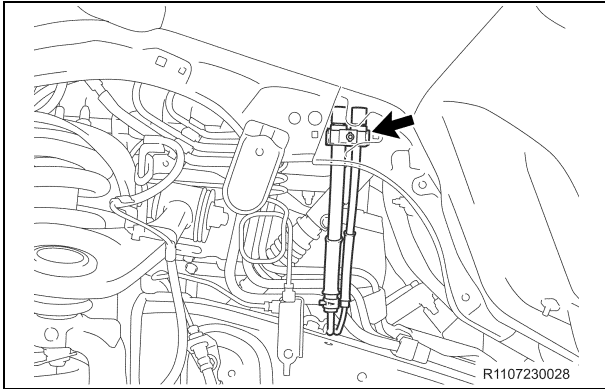

19. DISCONNECT THE FRONT DIFFERENTIAL VACUUM HOSES (4WD ONLY)

- a) Disconnect the clamp and vacuum hoses.

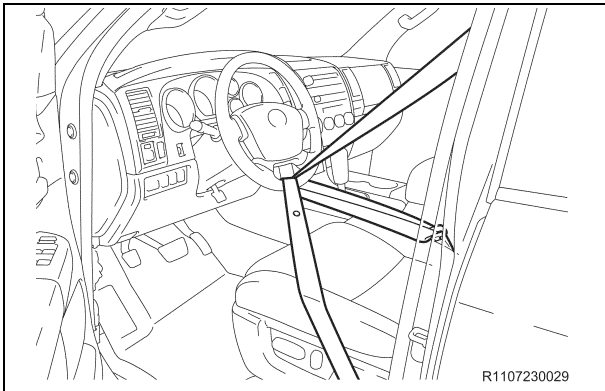

20. DISCONNECT THE No.2 STEERING INTERMEDIATE SHAFT

- a) Make sure the front wheels are in a straight-ahead position and the steering wheel is centered.
- b) Reconnect the front seat outer belt assy LH. **(Regular Cab Only)**
- c) Using the seat belt, hold the steering wheel in position as shown in the illustration, in order to prevent damage to the spiral cable.
- d) Place matchmarks on the intermediate shaft and No.2 intermediate shaft.
- e) Remove the bolt.
- f) Disconnect the intermediate shaft from the No.2 intermediate shaft.

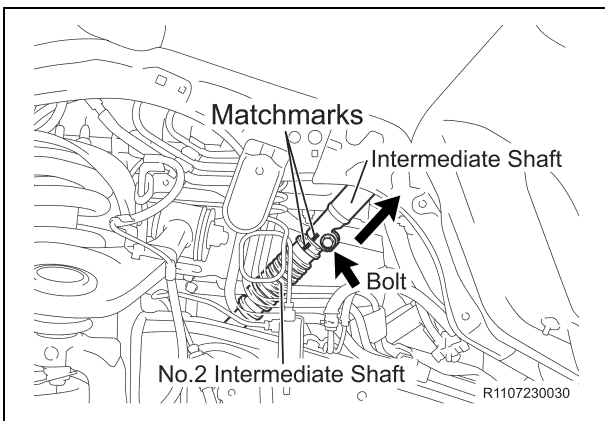

NOTE:

If the intermediate shaft cannot be pulled out completely, spread the gap of the sliding yoke with a flathead screwdriver or a wrench and pull out the intermediate shaft.

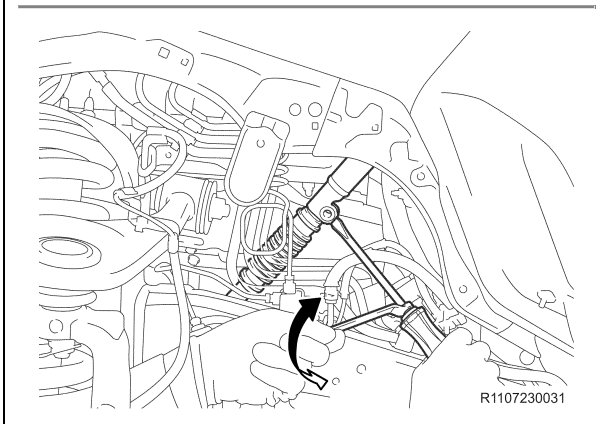

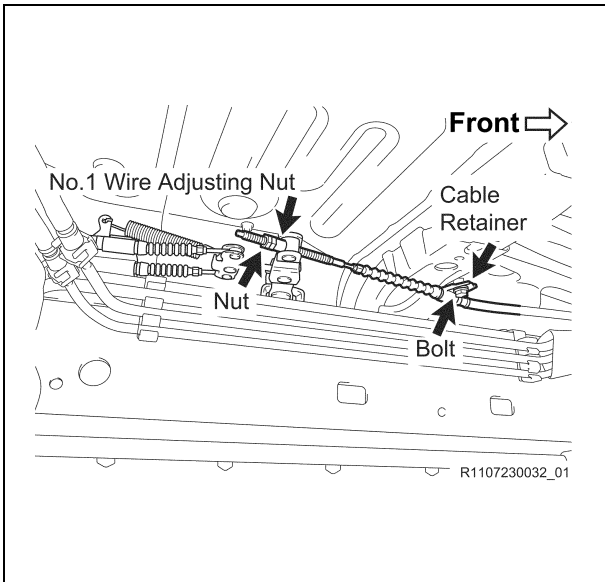

21. DISCONNECT THE No.1 PARKING BRAKE CABLE

- a) Remove the nut and No.1 wire adjusting nut.

NOTE:

If No.1 wire adjusting nut is too rusty to remove, then separate parking brake mechanism from frame.

- b) Remove the bolt and cable retainer.
- c) Disconnect the No.1 parking brake cable.

NOTE:

Use precaution when performing this step, as you will need to work underneath the vehicle.

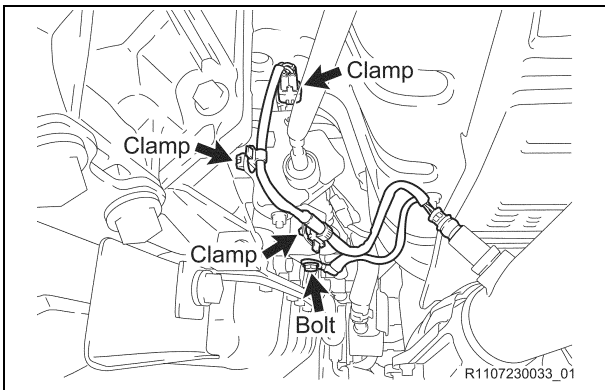

22. DISCONNECT THE TRANSMISSION CONTROL CABLE

- a) Remove the bolt and disconnect the ground wire.
- b) Disconnect the 3 clamps.

NOTE:

Use precaution when performing this step, as you will need to work underneath the vehicle.

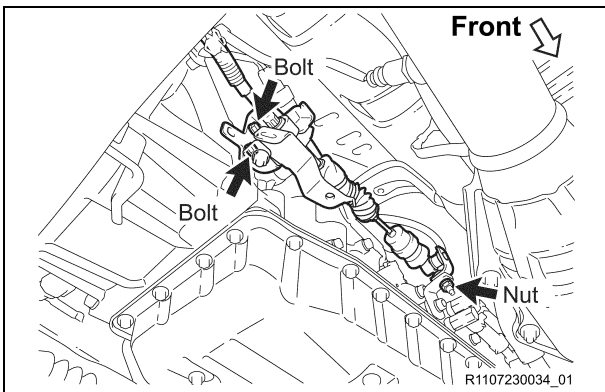

- c) Remove the nut.
- d) Remove the 2 bolt and disconnect the transmission control cable.

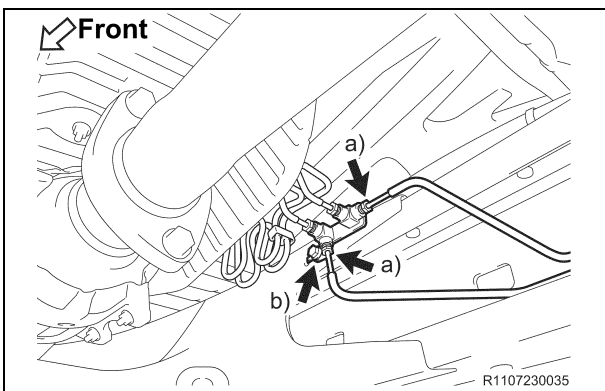

23. DISCONNECT THE REAR BRAKE TUBES

- a) Disconnect the 2 rear brake tubes.
- b) Remove the bolt and disconnect brake tube.

NOTE:

Use precaution when performing this step, as you will need to work underneath the vehicle.

24. REINSTALL THE FRONT WHEELS

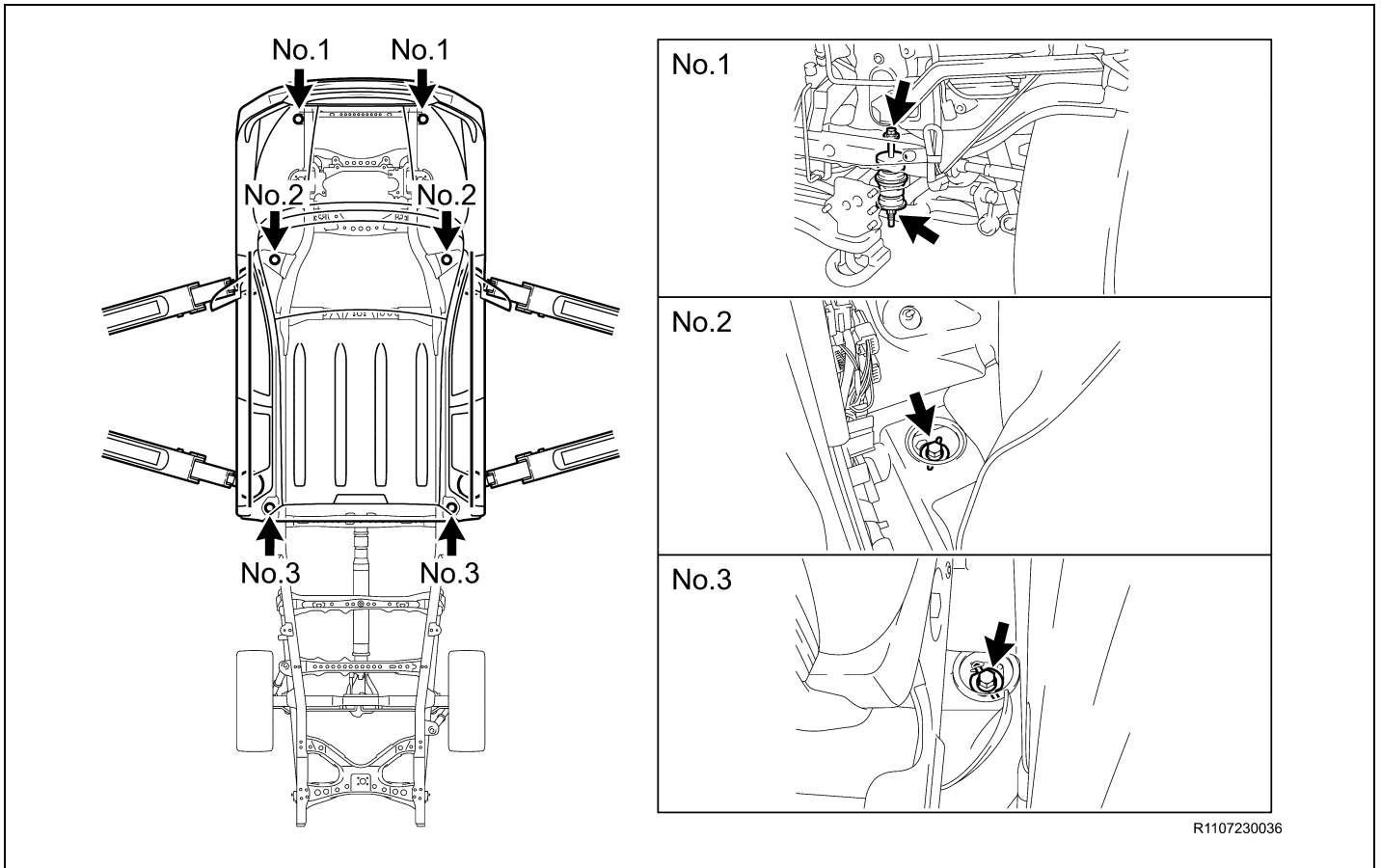

25. REMOVE THE CAB BODY ASSY USING AN ABOVE GROUND LIFT

- Remove the 6 bolts, 6 nuts, 4 washers and 2 No.1 lower cab mounting cushion sub-assy.
- Set the lift arms under the cab body assy so they **DO NOT** interfere with the frame or cab mounts.
- Check that all wire harnesses, hoses, cables and the steering shaft are disconnected.
- Lift the cab assy up slowly, making sure it does not interfere with anything while being raised.
- Raise the cab assy high enough so that the top of the engine clears the lowest point of the cab assy.
- Pull the frame assy out from under the vehicle.
- Lower the cab assy all the way down and leave it on the lift.

NOTE:

- Center the cab assy weight on the lift arms so that it does not slant/tilt to one side.
- Raise the cab assy slightly off the frame and verify that it is held securely by the lift arms.
- The center of gravity position of the cab body may become inappropriate depending on the shape of the lift arm used and under such situation the cab body may fall when lifted. To prevent falling off of the cab body, use some weights to establish right balance and secure the cab body to the lift arm using ratchet tie down belts.
- DO NOT** work directly underneath the vehicle when pulling the frame assy out from under.
- DO NOT** remove the cab mount bolts, as they will be used as guides during cab assy reinstallation process.

F. DISASSEMBLE THE FRAME

1. PLACE THE FRAME ON A LIFT

a) Place the frame on the lift, and secure it with a ratcheting tie down strap. This will prevent the frame from tilting or falling off as parts are removed.

- **Ratcheting Tie Downs: Qty 1**
 - **Length: 2 in X 27 ft**
 - **Minimum Work Load Capacity: 3,000 lbs**

2. REMOVE THE FOLLOWING PARTS

- Spare Tire
- Wheels

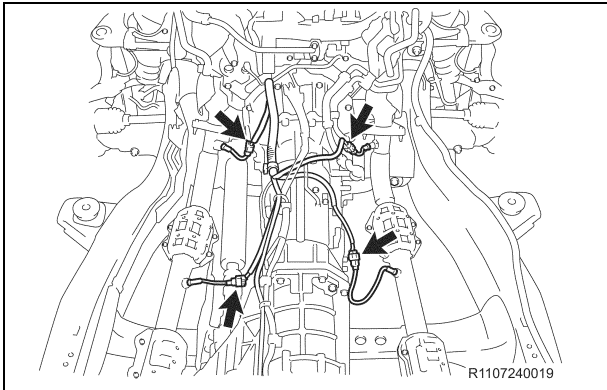

3. DISCONNECT THE OXYGEN SENSOR CONNECTORS

a) Disconnect the 4 oxygen sensor connectors.

4. REMOVE THE FOLLOWING PARTS

- Propeller Shaft Heat Insulator (**4WD Only**)
- Front Propeller Shaft Assy (**4WD Only**)
- Rear Propeller Shaft Assy
 - Insert **SST 09325-40010 (A750E)** or **SST 09325-60010 (AB60E)** into the transmission after the rear propeller shaft is removed to prevent oil leakage (**2WD Only**)

NOTE:

Make sure to place matchmarks on the front (if equipped) and rear propeller shafts prior to removal.

5. REMOVE THE FOLLOWING PARTS

- No.1 Fuel Tank Protector Sub-Assy (**If Equipped**)
- Fuel Tank Strap
- Fuel Tank Assy
- Charcoal Canister Assy

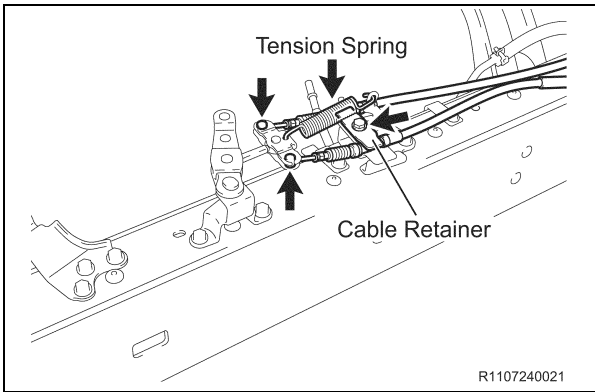

6. DISCONNECT THE PARKING BRAKE SYSTEM

- a) Remove the tension spring.
- b) Remove the bolt and cable retainer.
- c) Disconnect the 2 parking brake cables.

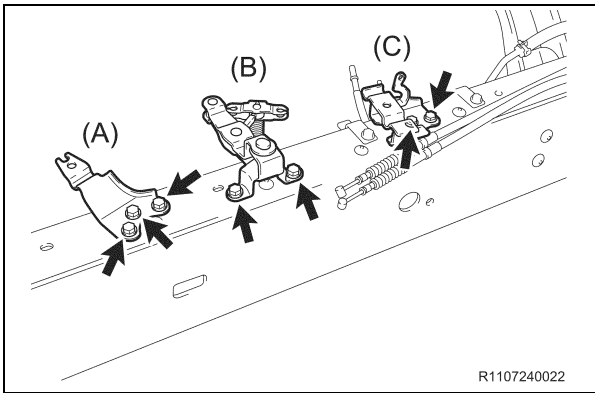

- d) Remove the 3 bolts and cable support bracket (A).
- e) Remove the 2 bolts and parking brake intermediate lever (B).
- f) Remove the 2 bolts and No.2 cable support bracket (C).

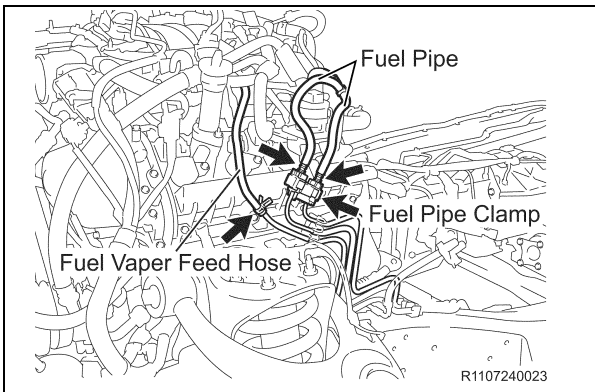

7. DISCONNECT THE FUEL PIPES

- a) Remove the No.1 fuel pipe clamp.
- b) Disconnect the 2 fuel pipes.

NOTE:

Put a shop towel under the fuel pipe to catch any spilled fuel.

8. DISCONNECT THE FUEL VAPOR FEED HOSE ASSY

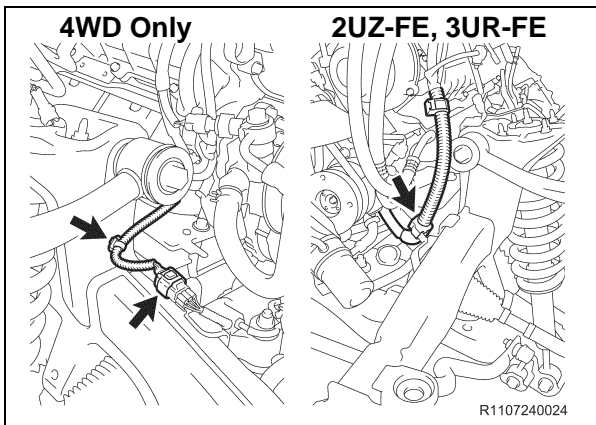

9. DISCONNECT THE ENGINE WIRE
(2UZ-FE, 3UR-FE ONLY)

10. DISCONNECT THE DIFFERENTIAL WIRE (4WD ONLY)

11. REMOVE AND SET ASIDE THE POWER STEERING PUMP ASSY

- a) Remove the drive belt.
- b) Disconnect the connectors.
- c) Disconnect the harness clamp. (**3UR-FE Only**)
- d) Remove the 2 bolts and nut (**2UZ-FE Only**) or the 2 bolts (**1GR-FE, 3UR-FE Only**) and the power steering vane pump.

NOTE:

- **DO NOT** disconnect the power steering pump hoses or tubes.
- **Make sure to keep the power steering pump reservoir in an upright position to prevent the fluid from leaking out.**

12. REMOVE THE INTAKE AIR SURGE TANK (1GR-FE ONLY)

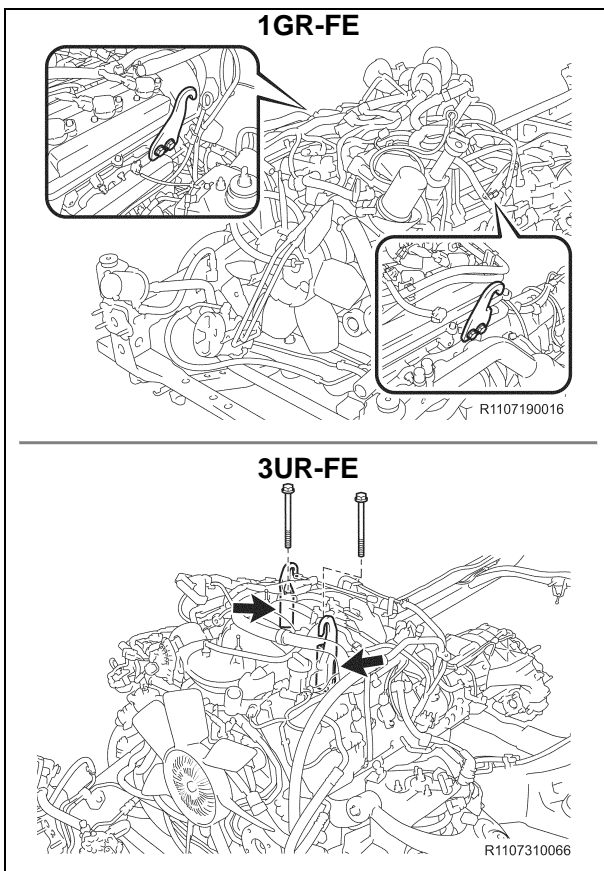

13. REMOVE THE ENGINE AND TRANSMISSION ASSY

- a) Disconnect and remove the necessary items/parts to prepare the engine and transmission assy for removal.
- b) Install the engine hanger. (**1GR-FE, 3UR-FE**)

For 1GR-FE

12281-31060 = Engine Hanger No.1, Qty: 1
 12282-31040 = Engine Hanger No.2, Qty: 1
 90119-08A87 = Bolt, Qty: 4

For 3UR-FE

12281-38150 = Engine Hanger No.1, Qty: 2
 90119-14120 or 90119-A0166 = Bolt, Qty: 2

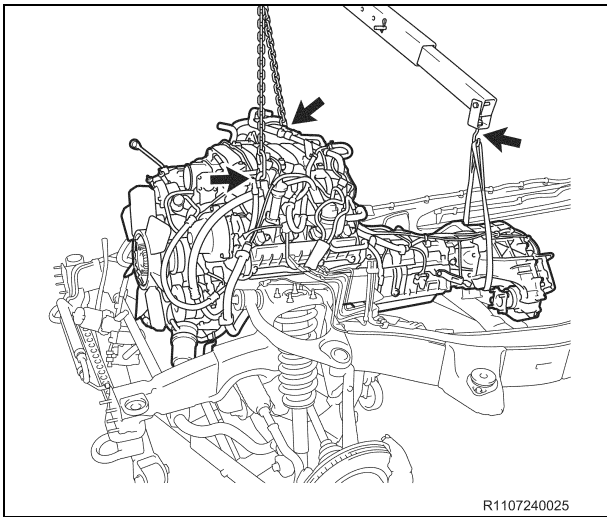

c) Remove the engine and transmission assy.

NOTE:

- When removing the engine and transmission assy, **ALWAYS** use 2 engine hoists or mini cranes to lift it.
- **DO NOT** use 1 engine hoist or mini crane to lift the engine and transmission assy, as the unbalanced weight may lead to an accident or injury.
- **ONLY** use engine hoists or mini cranes that can properly support the weight of the engine and transmission assy.
- Carefully adjust the 2 engine hoists or mini cranes used so that the engine and transmission assy is properly balanced.

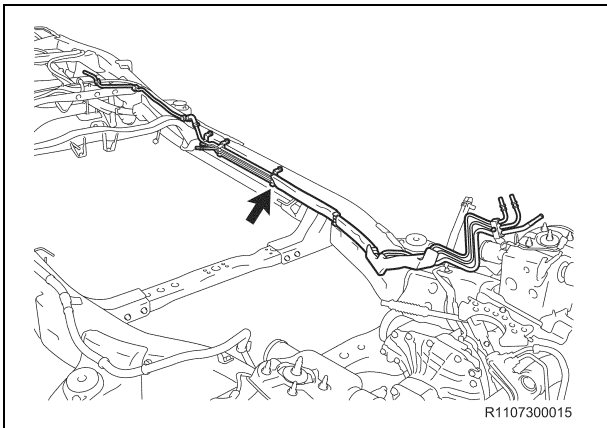

14. REMOVE THE FUEL TUBES

a) Remove the bolts, clamps and fuel tubes.

NOTE:

- The number of clamps will differ depending on the vehicle specification.
- Take care not to damage or break the clamps during removal.

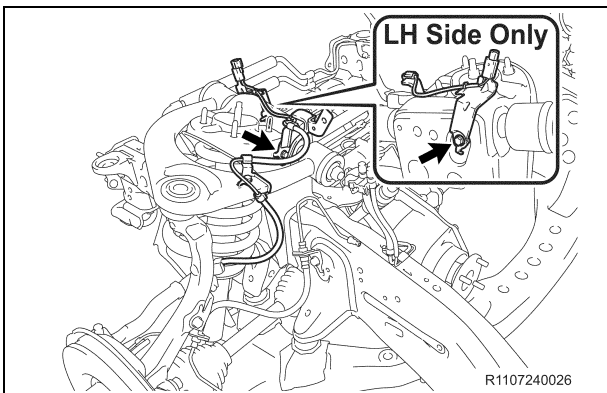

15. DISCONNECT THE SKID CONTROL SENSOR WIRES

- Remove the 2 bolts and disconnect the skid control sensor wire. (**LH Side**)
- Remove the bolt and disconnect the skid control sensor wire. (**RH Side**)

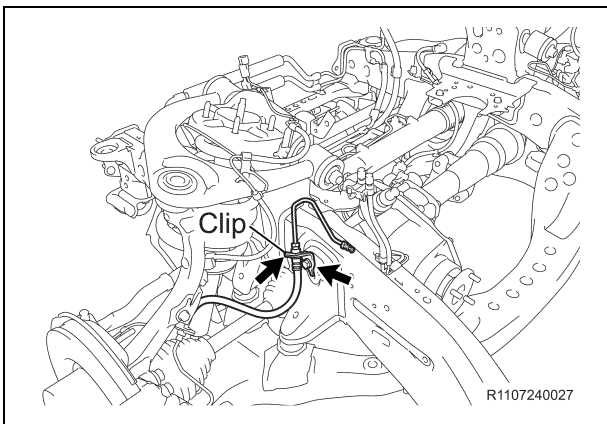

16. DISCONNECT THE FRONT BRAKE HOSES

- Disconnect the brake tube from the brake hose
- Remove the clip.
- Remove the bolt and disconnect the front brake hose.
- Repeat the procedure on the opposite side.

17. REMOVE THE FOLLOWING PARTS

- Front Stabilizer Bar
- Front Axle Shaft Nut (**4WD Only**)
- Tie Rod End Sub-Assy
 - Remove the cotter pin and nut.
 - Using the **SST 09610-20012**, disconnect the tie rod end.
- Lower Ball Joint
 - Remove the 2 bolts and disconnect the lower ball joint from the steering knuckle.

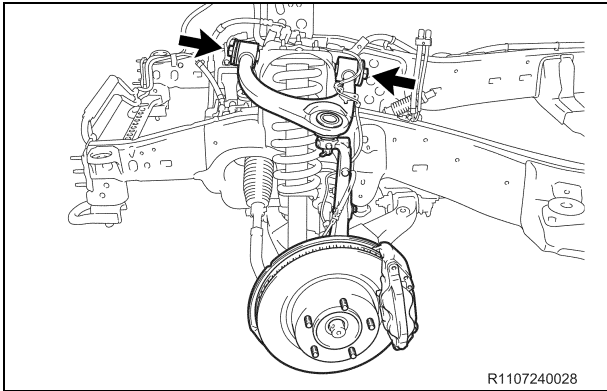

18. REMOVE THE FRONT SUSPENSION UPPER ARM AND STEERING KNUCKLE ASSY

- a) Remove the bolt, nut, 2 washers and front suspension upper arm w/ steering knuckle.
- b) Repeat the procedure on the opposite side.

NOTE:

If the drive shaft is difficult to disconnect, tap the drive shaft loose with a plastic hammer. (**4WD Only**)

19. REMOVE THE FOLLOWING PARTS

- Front Shock Absorber Assy
- Front Drive Shaft Assy (**4WD Only**)
 - Using the **SST 09520-24010 (09520-32040), 09520-01010**, remove the front drive shaft

NOTE:

Be careful not to damage the dust cover and oil seal.

- Power Steering Link Assy w/ Power Steering Vane Pump

NOTE:

- When removing the power steering link with the vane pump attached, have one person support the power steering link and the other support the vane pump.
- Make sure to keep the power steering pump reservoir in an upright position to prevent the fluid from leaking out.

- Front Differential Carrier Assy (**4WD Only**)
- Front Suspension Lower Arm Sub-Assy

NOTE:

If the bolt is seized and the front suspension lower arm cannot be removed, remove the lower ball joint with the front suspension lower arm left on the frame.

- Lower Ball Joint

NOTE:

When the front suspension arm can be removed, this work is not required.

- Remove the cotter pin and nut.
 - Using the **SST 09950-40011 (09951-04010,09953-04020,09954-04010,09955-04031,09958-04011,09952-04010),09955-04090**, remove the lower ball joint.
- No.1 Front Spring Bumper (Qty: 4)
 - Using the **SST 09922-10010-01**, remove the front spring bumper.

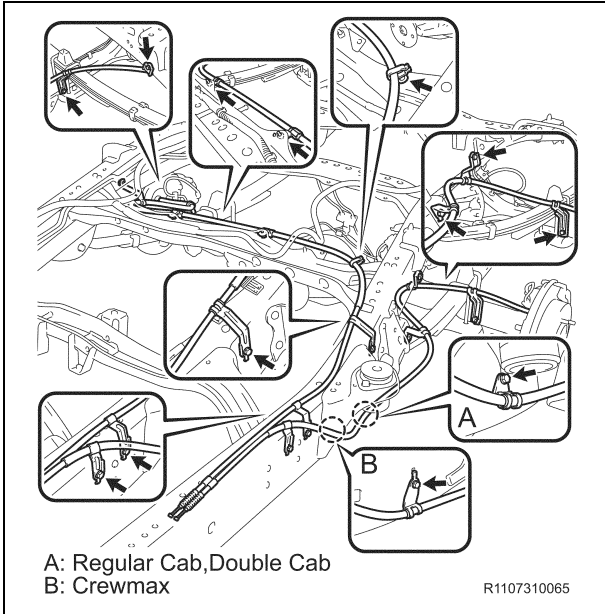

20. DISCONNECT THE PARKING BRAKE CABLE

- a) Remove the 11 bolts, clamp and disconnect the parking brake cable.

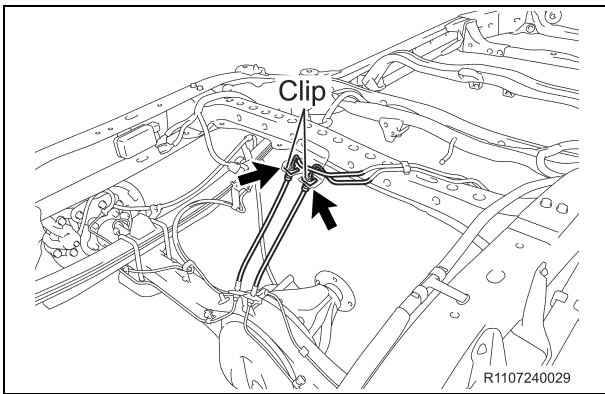

21. DISCONNECT THE REAR BRAKE TUBES

- a) Disconnect the No.4 rear brake tube.
- b) Disconnect the No.5 rear brake tube.
- c) Remove the 2 clip and disconnect the flexible hose.

22. REMOVE THE FOLLOWING PARTS

- Rear Shock Absorber Assy
- Rear Differential Assy
- Fuel Pump Control Computer Assy

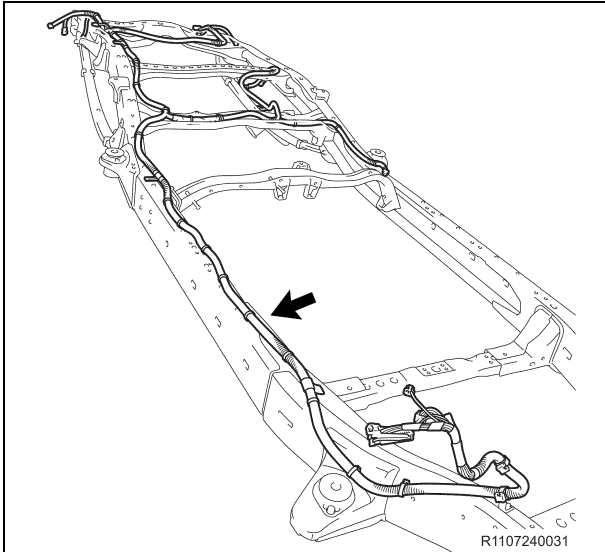

23. REMOVE THE FRAME WIRE HARNESS

- a) Remove the bolt and disconnect the ground wire.
(If Equipped)
- b) Disconnect the clamps and remove the frame wire harness.

NOTE:

- The number of wire harness clamps will differ depending on the vehicle specification.
- Take care not to damage or break the wire harness clamps during removal.

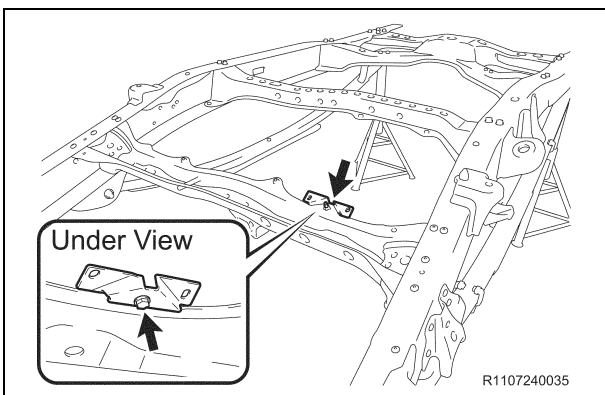

24. REMOVE THE No.6 FUEL TUBE CLAMP

- a) Remove the bolt and No.6 fuel tube clamp.

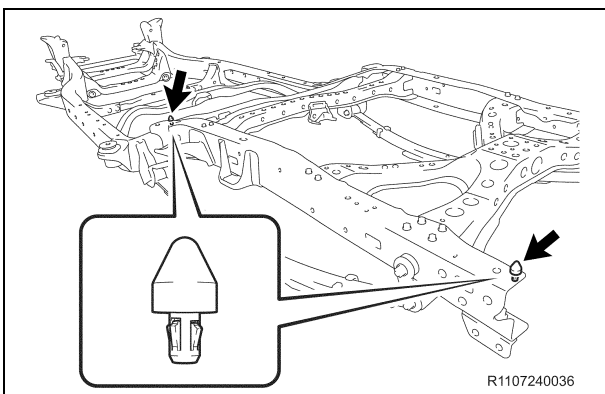

25. REMOVE THE CLIPS

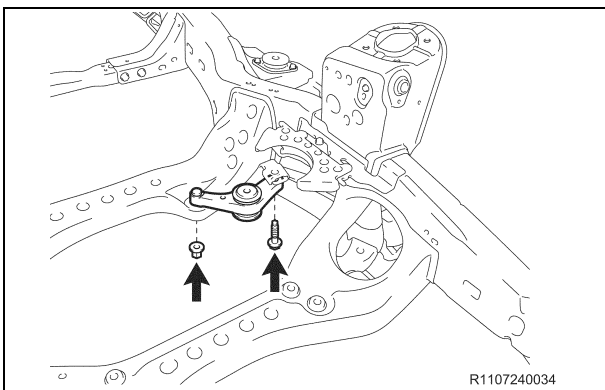

26. REMOVE THE FRONT DIFFERENTIAL SUPPORT ASSY (4WD ONLY)

- a) Remove the bolt, nut and differential support assy.

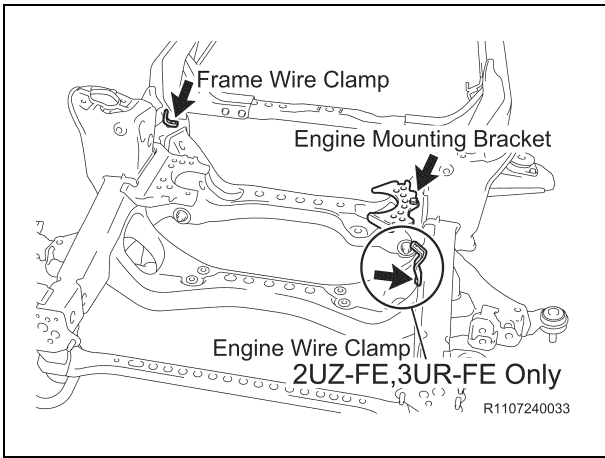

27. REMOVE THE ENGINE WIRE CLAMP (2UZ-FE, 3UR-FE ONLY)

28. REMOVE THE FRAME WIRE CLAMP

29. REMOVE THE No.2 FRONT ENGINE MOUNTING BRACKET LH

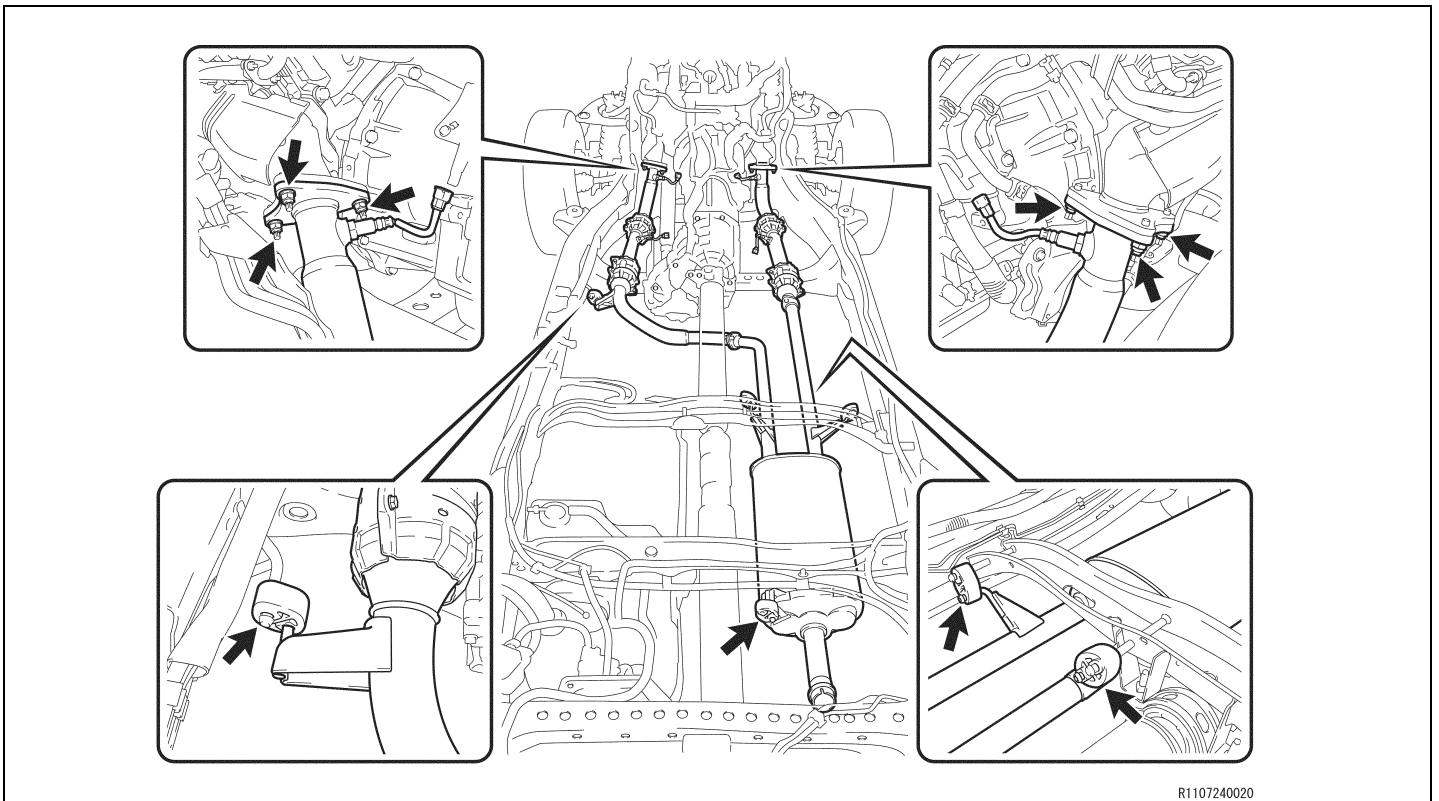

R1107240020

30. REMOVE THE EXHAUST SYSTEM

- a) Remove the 6 nuts.
- b) Remove the exhaust pipe and 4 exhaust pipe supports.
- c) Remove the 2 exhaust pipe gaskets.
- d) Remove the exhaust tail pipe and exhaust tail pipe support.

31. REMOVE THE FRAME FROM THE LIFT

- a) Remove the ratcheting tie down strap and the frame from the lift.

G. ASSEMBLE THE NEW FRAME

1. PLACE THE *NEW* FRAME ON THE LIFT

a) Place the **NEW** frame on the lift, and secure it with a ratcheting tie down strap. This will prevent the frame from tilting or falling off as parts are installed.

- Ratcheting Tie Downs: Qty 1
 - Length: 2 in X 27 ft
 - Minimum Work Load Capacity: 3,000 lbs

H. INSTALLATION OF BODY PLUGS

1. REMOVE THE PLASTIC SHEET
2. INSTALL THE PLUGS AS SHOWN BELOW

1/2 PLUG INSTALLATION

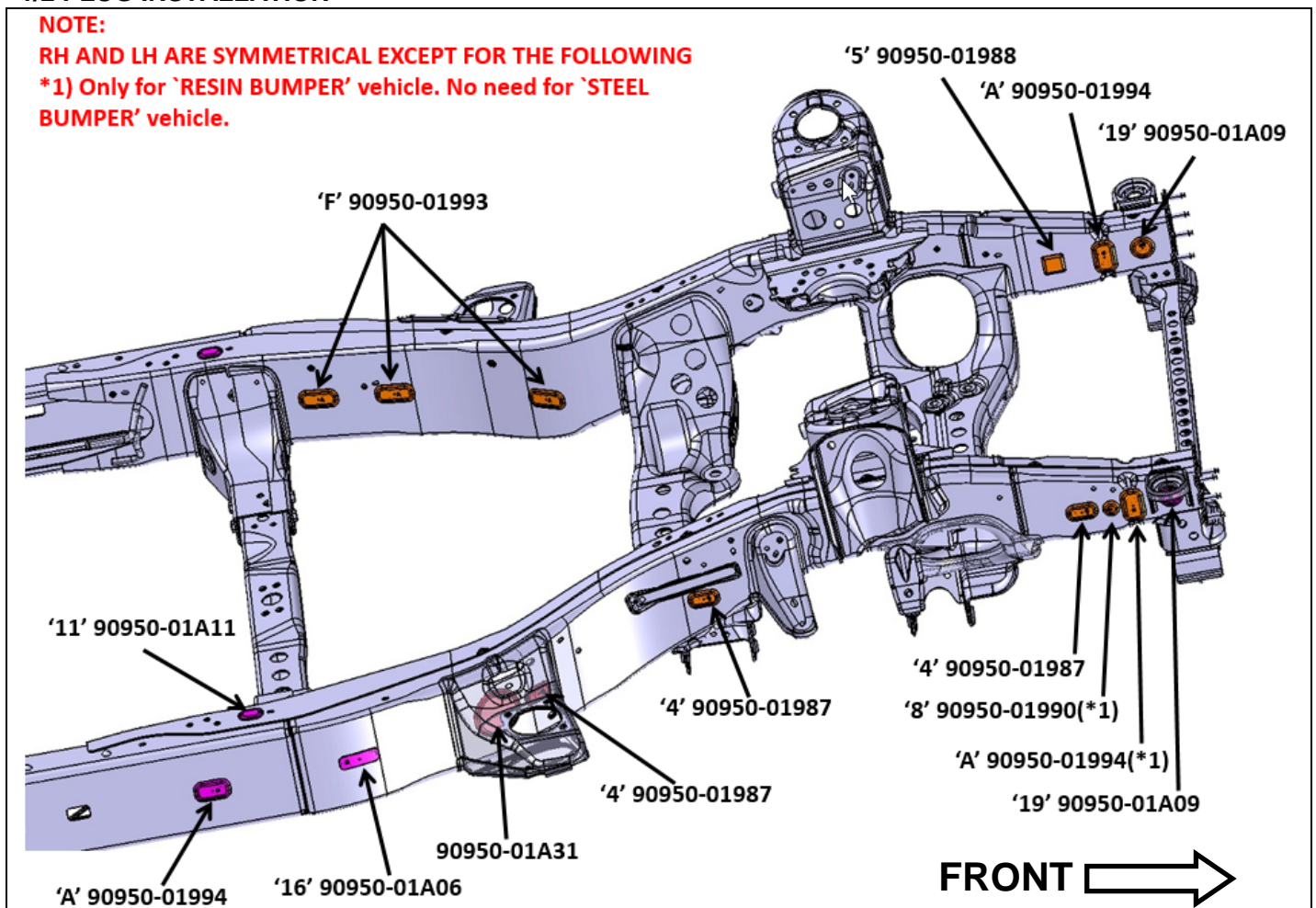

2/2 PLUG INSTALLATION

BOTTOM SIDE

**NOTE:
RH AND LH ARE SYMMETRICAL.**

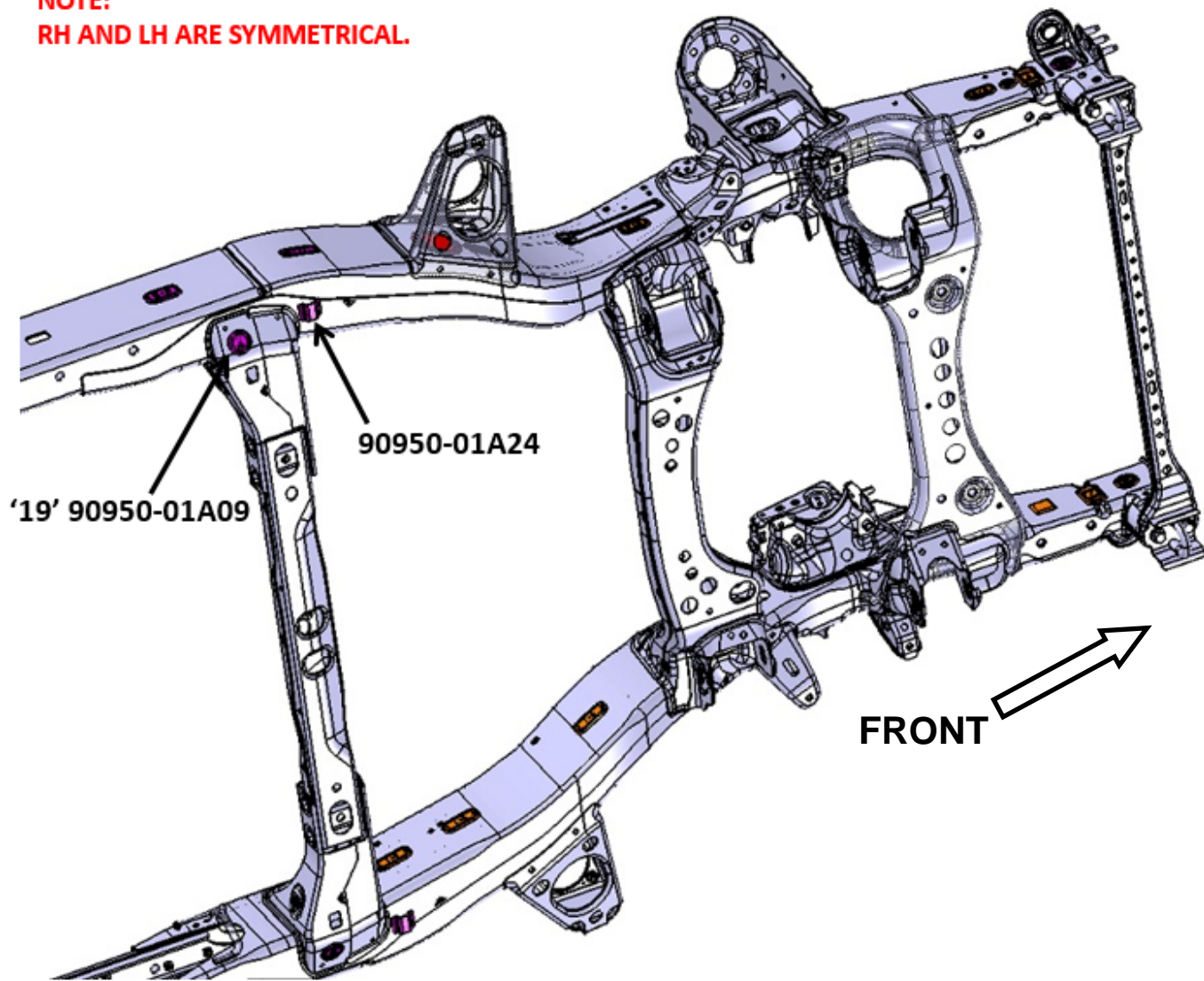

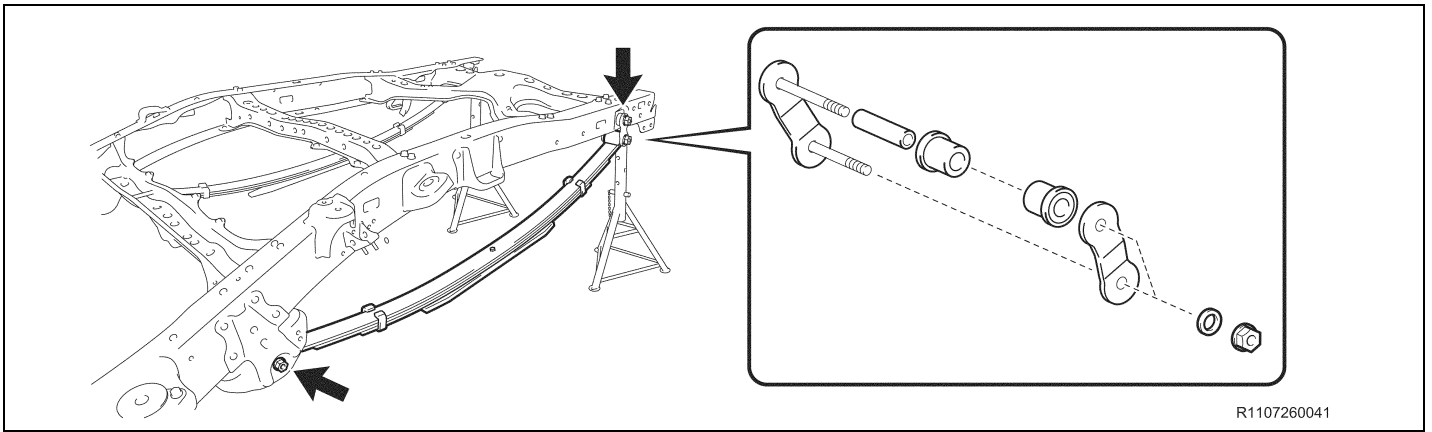

NEW Replacement Parts

| Part Number | Part Description | Kit # | Quantity |
|----------------------------------|-----------------------------|-------|----------|
| 04483-0C040 | Shackle Kit, Rear Spring RH | 2 | 1 |
| 04483-0C040 | Shackle Kit, Rear Spring LH | 2 | 1 |
| 90080-10138 or 90105-A0381 | Bolt | 2 | 2 |
| 90178-A0050 | Nut | 2 | 2 |
| 94622-51400 | Washer | 1 | 2 |
| Varies ** | Rear Leaf Spring (LH) | Na* | 1 |
| Varies ** | Rear Leaf Spring (RH) | Na* | 1 |

* Individual Part(s)

** Only 1 part is used. The part number depending on the list

2. INSTALL THE REAR LEAF SPRINGS

- a) Install the **NEW** rear leaf spring with all **NEW** parts (shackle, bushings, bolts, washers & nuts) and torque to spec.

Torque Spec: 77 ft·lbs (105 N·m, 1071 kgf·cm)

- b) Repeat the procedure on the opposite side.

NEW Replacement Parts

| Part Number | Part Name | Kit # | Qty |
|-------------|-----------|-------|-----|
| 90119-A0080 | Bolt | 2 | 8 |

R1107250046

3. REINSTALL THE CAB MOUNTS

- a) Reinstall cab mounts No.1.
- b) Reinstall cab mounts No.2 & No.3 with 8 **NEW** bolts and torque to spec.

Torque Spec: 45 ft-lbs (61 N·m, 622 kgf·cm)

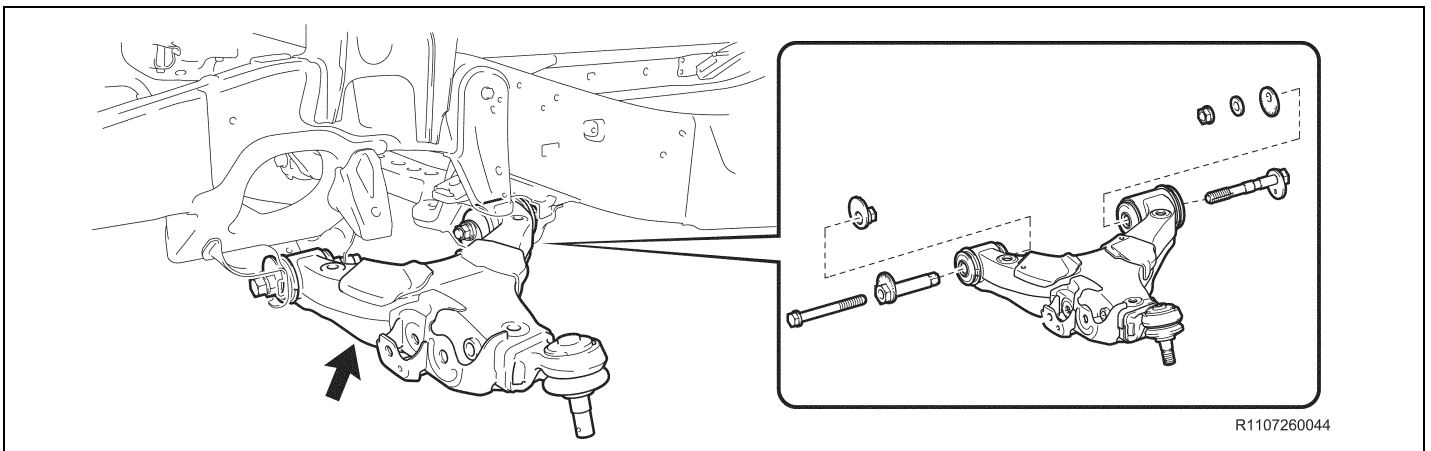

NEW Replacement Parts

| Part Number | Part Name | Kit # | Qty |
|-------------|--|-------|-----|
| 48068-09100 | Arm, Sub-Assy, Front Suspension, Lower No.1 RH | NA* | 1 |
| 48069-09090 | Arm, Sub-Assy, Front Suspension, Lower No.1 LH | NA* | 1 |
| 48190-34010 | Cam Assy, Camber Adjust | 1 | 2 |
| 48198-34010 | Cam, Camber Adjust, No.2 | 1 | 2 |
| 48409-34041 | Cam Sub-Assy, Front Suspension Toe Adjust | 1 | 2 |
| 48452-34011 | Plate, Front Suspension Toe Adjust, No.2 | 1 | 2 |
| 90119-A0204 | Bolt | 2 | 2 |
| 90178-18003 | Nut | 1 | 2 |
| 90201-19011 | Washer | 1 | 2 |

* Individual Part(s)

4. INSTALL THE FRONT SUSPENSION LOWER ARMS

- a) Install the **NEW** front suspension lower arm with **NEW** bolt, **NEW** toe adjusting cam, **NEW** toe adjusting plate, **NEW** nut, **NEW** washer, **NEW** No.2 camber adjusting cam, **NEW** camber adjusting cam, then torque to spec.

Torque Spec: 207 ft-lbs (280 N·m, 2855 kgf·cm)

- b) Repeat the procedure on the opposite side.

5. REINSTALL THE LOWER BALL JOINTS

NOTE:

- If the front suspension lower arm is to be replaced with a new one, install the lower ball joint on the new front suspension lower arm.
- If the holes for the cotter pin are not aligned, tighten the axle nut further, up to 60 degree.

a) Reinstall the lower ball joint with the nut and torque to spec.

Torque Spec: 123 ft·lbs (167 N·m, 1703 kgf·cm)

- b) Install the **NEW** cotter pin.
 c) Repeat the procedure on the opposite side.

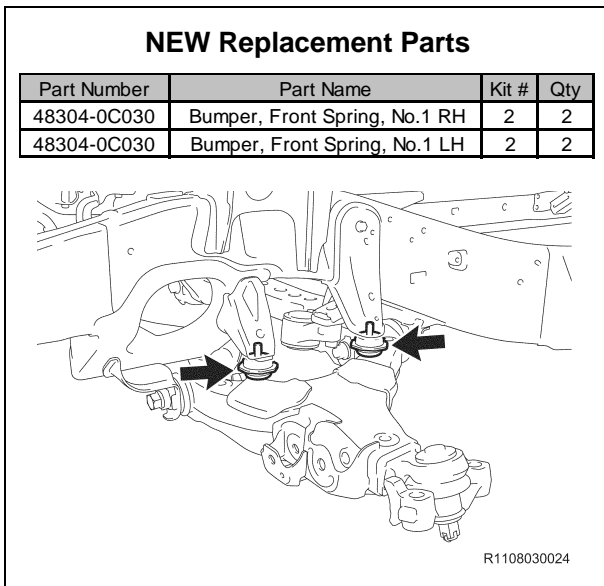

6. INSTALL THE No.1 SPRING BUMPERS

a) Install the 2 **NEW** front spring bumpers to the frame and torque to spec.

Torque Spec: 23 ft·lbs (31 N·m, 316 kgf·cm)

b) Repeat the procedure on the opposite side.

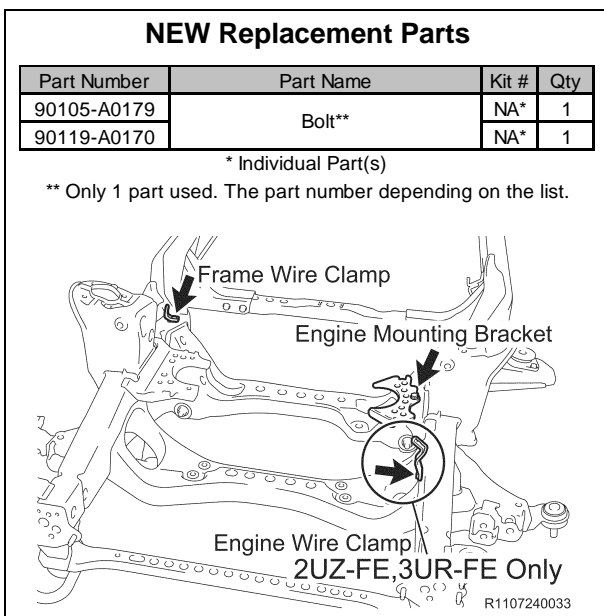

7. REINSTALL THE ENGINE WIRE CLAMP (2UZ-FE, 3UR-FE ONLY)

Torque Spec: 13 ft·lbs (17.2 N·m, 175 kgf·cm)

8. REINSTALL THE FRAME WIRE CLAMP

Torque Spec: 23 ft·lbs (31 N·m, 316 kgf·cm)

9. REINSTALL THE No.2 FRONT ENGINE MOUNTING BRACKET LH

Torque Spec: 24 ft·lbs (32 N·m, 326 kgf·cm)

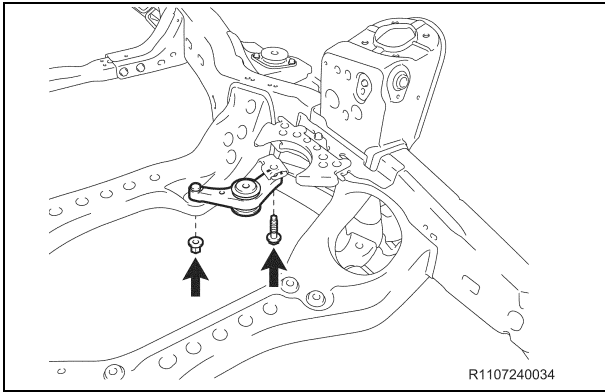

10. REINSTALL THE FRONT DIFFERENTIAL SUPPORT ASSY (4WD ONLY)

- a) Reinstall the front differential support with the nut and bolt, then torque to spec.

Torque Spec: 83 ft·lbs (113 N·m, 1152 kgf·cm)

NEW Replacement Parts

| Part Number | Part Name | Kit # | Qty |
|-------------|-----------------------------|-------|-----|
| 52238-0C010 | Holder, Body Mounting, Rear | 2 | 2 |

11. INSTALL THE CLIPS

NEW Replacement Parts

| Part Number | Part Name | Kit # | Qty |
|-------------|------------------------|-------|-----|
| 77414-0C010 | Clamp, Fuel Tube, No.6 | 2 | 1 |
| 90105-A0179 | Bolt | NA* | 1 |

* Individual Part(s)

12. INSTALL THE No.6 FUEL TUBE CLAMP

- a) Install the **NEW** No.6 fuel tube clamp with the **NEW** bolt, and torque to spec.

Torque Spec: 23 ft·lbs (31 N·m, 316 kgf·cm)

NEW Replacement Parts

| Part Number | Part Name | Kit # | Qty |
|-------------|---------------------------|-------|-----|
| 47324-0C060 | Tube, Rear Brake, No.4** | NA* | 1 |
| 47324-0C080 | | NA* | 1 |
| 47324-0C090 | | NA* | 1 |
| 47325-0C090 | Tube, Rear Brake, No.5** | NA* | 1 |
| 47325-0C100 | | NA* | 1 |
| 47325-0C110 | | NA* | 1 |
| 90469-A0004 | Clamp, Brake Tube, No.7** | NA* | 7 |
| 90469-A0004 | | NA* | 8 |
| 90469-A0004 | | NA* | 9 |

* Individual Part(s)

** Only 1 part used. The part number depending on the list.

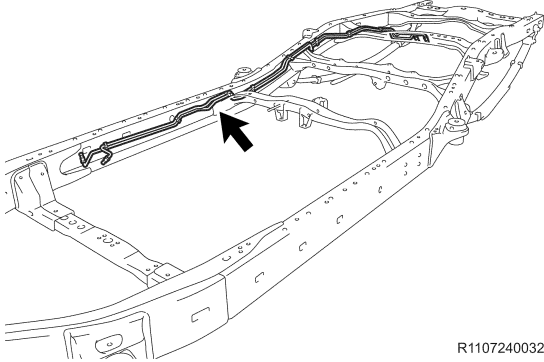

R1107240032

13. INSTALL THE REAR BRAKE TUBES

- a) Install the **NEW** rear brake tubes with the **NEW** clamp(s).

NOTE:

The number of clamps will differ depending on the vehicle spec.

NEW Replacement Parts

| Part Number | Part Name | Kit # | Qty |
|-------------|-------------|-------|-----|
| Varies** | Wire, Frame | NA* | 1 |

* Individual Part(s)

** Only 1 part used. The part number depending on the list.

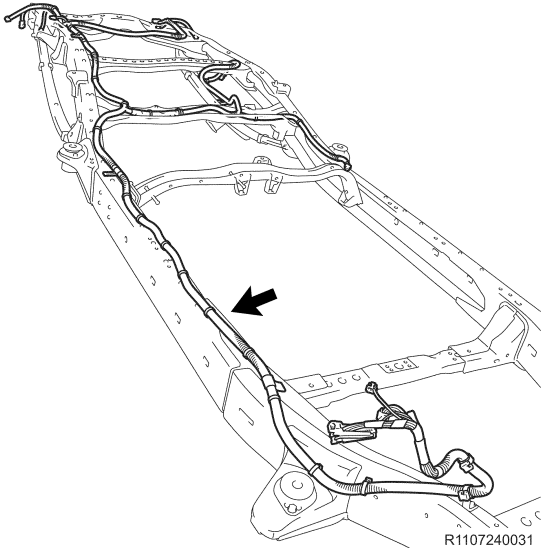

R1107240031

14. INSTALL THE FRAME WIRE HARNESS

- a) Connect the clamps to install the **NEW** frame wire harness.
 b) Connect the ground wire with the bolt and torque to spec. **(If Equipped)**

Torque Spec: 22 ft·lbs (29.3 N·m, 299 kgf·cm)

NOTE:

The number of wire harness clamps will differ depending on the vehicle spec.

NEW Replacement Parts

| Part Number | Part Name | Kit # | Qty |
|-------------|---------------------------|-------|-----|
| 90119-A0169 | Bolt | 2 | 4 |
| 51900-34050 | Carrier Assy, Spare Wheel | NA* | 1 |

* Individual Part(s)

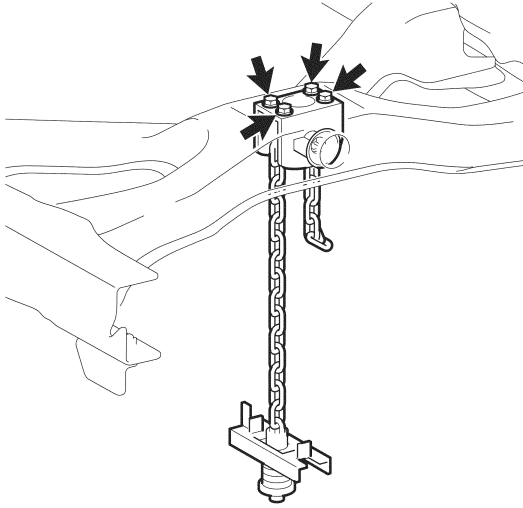

R1407140037

15. INSTALL THE SPARE WHEEL CARRIER ASSY

- a) Install the **NEW** spare wheel carrier assy with the 4 **NEW** bolts and torque to spec.

Torque Spec: 15 ft·lbs (20 N·m, 204 kgf·cm)

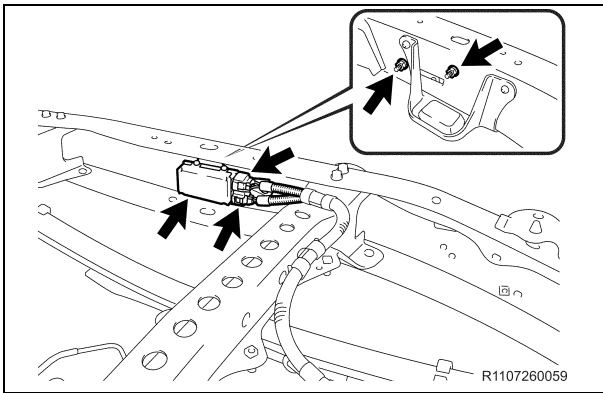

R1107260059

16. REINSTALL THE FUEL PUMP CONTROL COMPUTER ASSY

- a) Reinstall the fuel pump control computer with the 2 nuts and torque to spec.

Torque Spec: 14 ft·lbs (19.5 N·m, 199 kgf·cm)

- b) Reconnect the 2 connectors.

NEW Replacement Parts

| Part Number | Part Name | Kit # | Qty |
|-------------|------------------------------|-------|-----|
| 90117-A0003 | Bolt, U (For Rear Spring) ** | NA* | 4 |
| 90117-A0004 | | NA* | 4 |
| 90178-A0050 | Nut | 2 | 8 |
| 94622-51400 | Washer | 1 | 8 |
| 90178-A0071 | Nut | 2 | 2 |

* Individual Part(s)

** Only 1 part used. The part number depending on the list.

17. REINSTALL THE FOLLOWING PARTS

- Rear Differential Assy
 - Reinstall the rear differential assy with the 4 **NEW** U - bolts, 2 spring seats, 2 spring bumpers, 8 **NEW** mounting nuts and 8 **NEW** washers, then torque to spec.
 - **Torque Spec: 74 ft·lbs (100 N·m, 1020 kgf·cm)**
- Rear Shock Absorber Assy
 - Reinstall the rear shock absorber assy with the **NEW** nut, retainer and 2 cushions, then torque to spec.
 - **Torque Spec:**
Nut (Upper Side) - 21 ft·lbs (28 N·m, 286 kgf·cm)
 - Reinstall with the bolt, 2 nuts and torque to spec.
 - **Torque Spec:**
Nut (Lower Side) - 66 ft·lbs (90 N·m, 918 kgf·cm)
 - Repeat the procedure on the opposite side.

NEW Replacement Parts

| Part Number | Part Name | Kit # | Qty |
|-------------|-----------|-------|-----|
| 90468-A0007 | Clip | 2 | 2 |

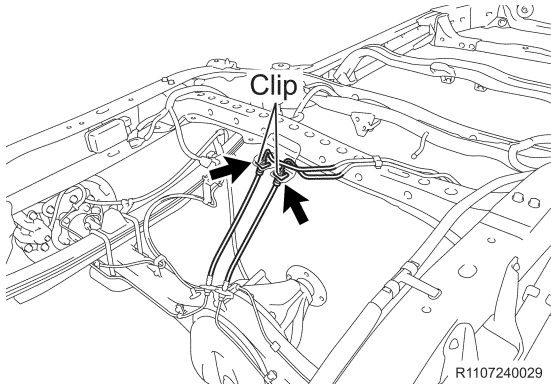

18. RECONNECT THE REAR BRAKE TUBES

- Reconnect the 2 flexible hose with a 2 **NEW** clips.
- Reconnect the 2 rear brake tube and torque to spec.

Torque Spec: 11 ft·lbs (15 N·m, 153 kgf·cm)

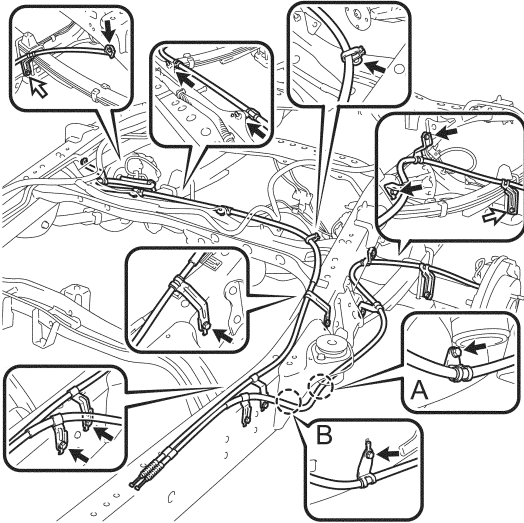

A: Regular Cab, Double Cab ← : Bolt A
 B: Crewmax ↙ : Bolt B R1107310065

19. REINSTALL THE PARKING BRAKE CABLE

- Reinstall the parking brake cables with the clamp and 11 bolts, then torque to spec.

Torque Spec:
Bolt A - 14 ft·lbs (19 N·m, 194 kgf·cm)
Bolt B - 10 ft·lbs (13.5 N·m, 138 kgf·cm)

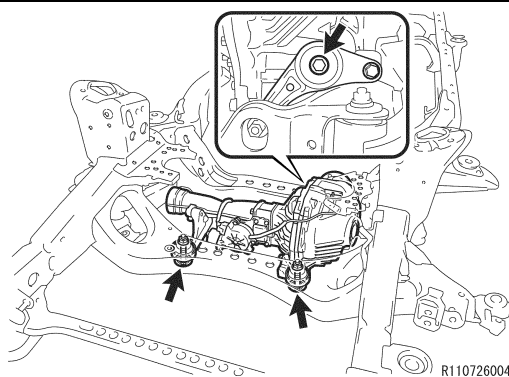

20. REINSTALL THE FRONT DIFFERENTIAL CARRIER ASSY (4WD ONLY)

- Reinstall the front differential carrier assy with the 3 bolts, 2 stoppers and 2 nuts, then torque to spec.

Torque Spec: 83 ft·lbs (113 N·m, 1152 kgf·cm)

NEW Replacement Parts

| Part Number | Part Name | Kit # | Qty |
|-------------|-----------|-------|-----|
| 90105-A0193 | Bolt | 4 | 1 |

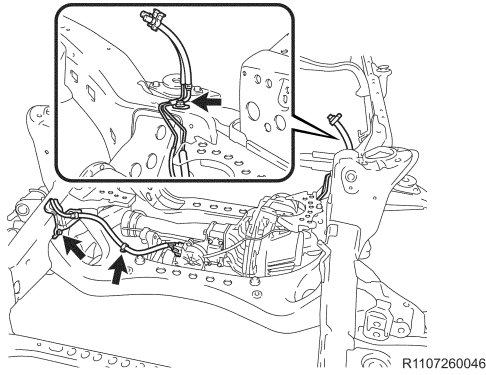

- b) Reinstall the breather tubes with the **NEW** bolt and torque to spec.

Torque Spec: 12 ft·lbs (16.6 N·m, 169 kgf·cm)

- c) Reinstall the differential wire connector with the bolt and clamp, then torque to spec.

Torque Spec: 13 ft·lbs (17.2 N·m, 175 kgf·cm)

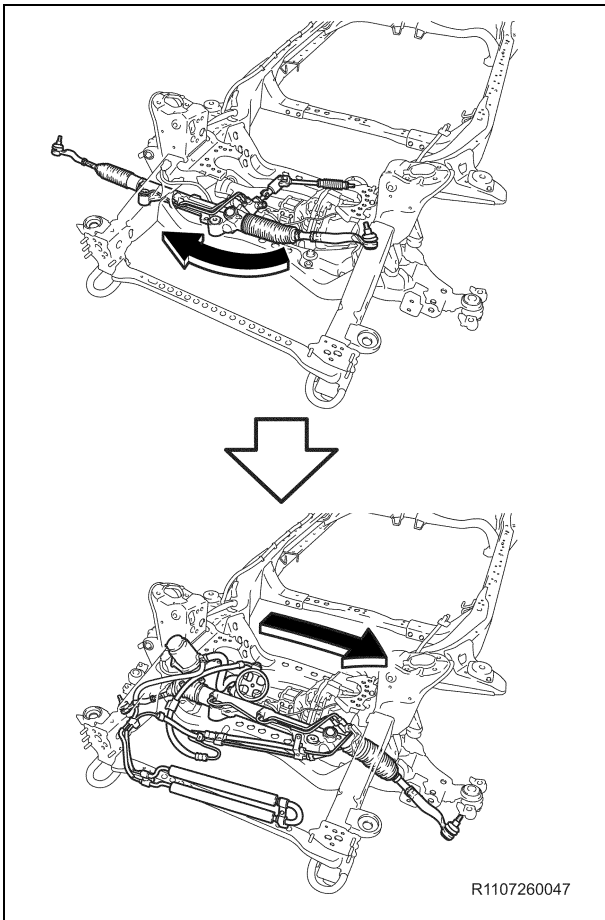

R1107260047

21. REINSTALL THE POWER STEERING LINK ASSY W/ POWER STEERING VANE PUMP

- a) Place the power steering link assy w/ power steering vane pump on the frame as shown in the figure.

NOTE:

- When reinstalling the power steering link with the vane pump attached, have one person support the power steering link and the other support the vane pump.
- Make sure to keep the power steering pump reservoir in an upright position to prevent the fluid from leaking out.
- Take care not to deform the power steering tube etc. during placement.

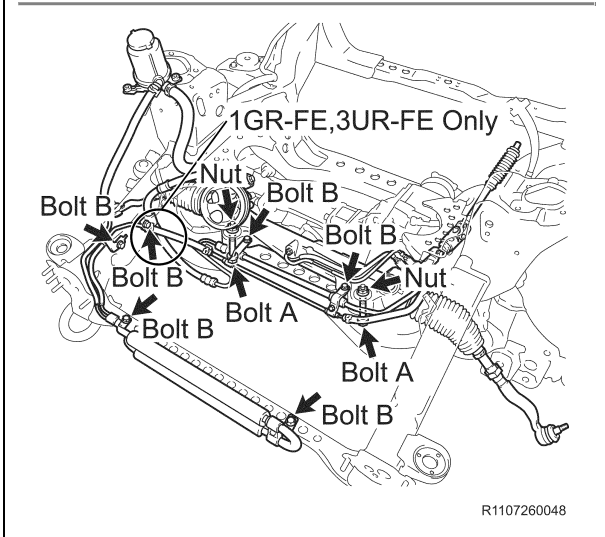

R1107260048

- b) Install the 2 bolts (A) and 2 nuts, then torque to spec.

Torque Spec: Nut - 89 ft·lbs (120 N·m, 1224 kgf·cm)

- c) Install the bolts (b) (2UZ-FE: 5 bolts, 1GR-FE, 3UR-FE: 6 bolts) and torque to spec.

Torque Spec: Bolt - B 21 ft·lbs (28 N·m, 286 kgf·cm)

NEW Replacement Parts

| Part Number | Part Description | Kit # | Quantity |
|----------------------------------|--|-------|----------|
| 90311-47012 or 90311-47027 | Seal, Oil (For Differential Side Gear Shaft) | 3 | 1 |
| 90311-47013 | Seal, Oil (For Differential Side Gear Shaft) | 3 | 1 |
| 43425-0C010 | Ring, Shaft Snap (For Front Drive Inner Shaft Outer) | 4 | 2 |

22. REINSTALL THE FRONT DRIVE SHAFT ASSY (4WD ONLY)

- a) Install a **NEW** snap ring.
- b) Reinstall the front drive shaft assy.
- c) Repeat the procedure on the opposite side.

NOTE:

- Be careful not to damage the dust cover and oil seal.
- If the oil seal is damaged, replace the **NEW** parts.

NEW Replacement Parts

| Part Number | Part Name | Kit # | Qty |
|-------------|------------------------------------|-------|-----|
| 90178-A0052 | Nut (For Front Suspension Support) | 2 | 8 |

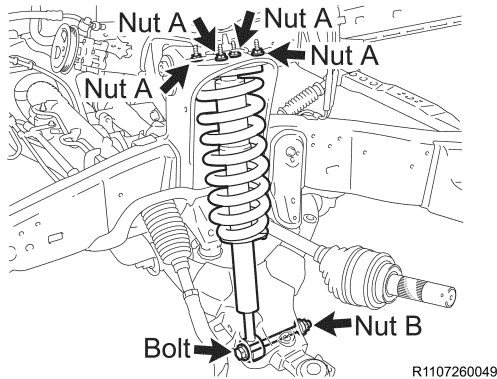

23. REINSTALL THE FRONT SHOCK ABSORBERS

- a) Reinstall the front shock absorber assy with the 4 **NEW** nuts (A) and torque to spec.

Torque Spec: Nut A - 33 ft-lbs (45 N·m, 459 kgf·cm)

- b) Reinstall the bolt and nut (B), then torque to spec.

Torque Spec: Nut B - 144 ft-lbs (195 N·m, 1988 kgf·cm)

- c) Repeat the procedure on the opposite side.

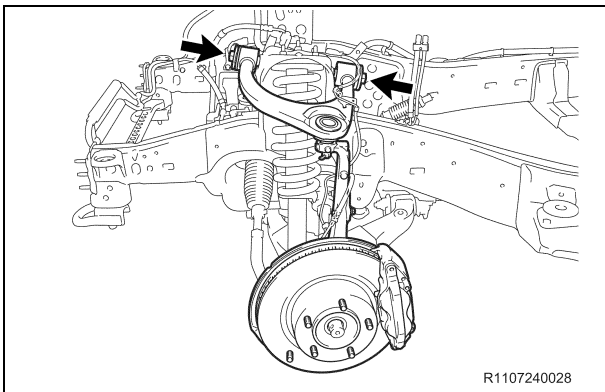

24. REINSTALL THE FRONT SUSPENSION UPPER ARM AND STEERING KNUCKLES

- a) Reinstall the front suspension upper arm w/ steering knuckle assy with the bolt, nut and 2 washers, then torque to spec.

Torque Spec: 173 ft-lbs (235 N·m, 2396 kgf·cm)

- b) Repeat the procedure on the opposite side.

NEW Replacement Parts

| Part Number | Part Name | Kit # | Qty |
|-------------|------------|-------|-----|
| 90252-04003 | Cotter Pin | 1 | 2 |
| 90119-A0192 | Bolt | 2 | 4 |

25. REINSTALL THE FOLLOWING PARTS

- Lower Ball Joint
 - Reinstall the lower ball joint with the 2 bolts and torque to spec.
 - **Torque Spec: 221 ft-lbs (300 N·m, 3059 kgf·cm)**
 - Repeat the procedure on the opposite side.
- Tie Rod End Sub-Assy
 - Reinstall the tie rod end with the nut and torque to spec.
 - **Torque Spec: 51 ft-lbs (69 N·m, 704 kgf·cm)**
 - Install the **NEW** cotter pin.
 - Repeat the procedure on the opposite side.
- Front Axle Shaft Nut (**4WD Only**)
 - Temporarily reinstall the front axle nut.
 - This nut will be tightened when the vehicle is completed.
 - Repeat the procedure on the opposite side.
- Front Stabilizer Bar
 - Reinstall the stabilizer bar with the 2 brackets and 4 **NEW** bolts, then torque to spec.
 - **Torque Spec: 51 ft-lbs (69 N·m, 704 kgf·cm)**
 - Reconnect the stabilizer links with the 2 bolts and torque to spec.
 - **Torque Spec: 89 ft-lbs (120 N·m, 1224 kgf·cm)**

NEW Replacement Parts

| Part Number | Part Name | Kit # | Qty |
|-------------|-----------|-------|-----|
| 90119-A0222 | Bolt | 2 | 2 |
| 90468-A0007 | Clip | 2 | 2 |

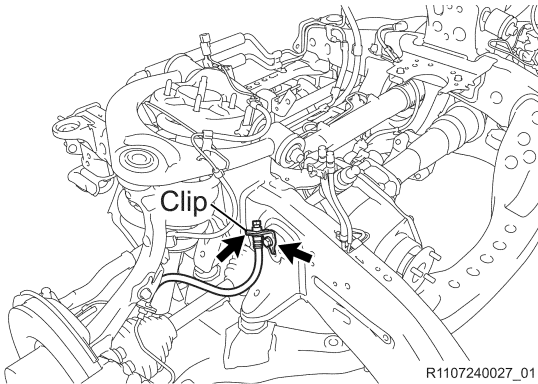

26. RECONNECT THE FRONT BRAKE HOSES

- a) Reinstall a bracket with a **NEW** bolt and torque to spec.

Torque Spec: 21 ft·lbs (29 N·m, 296 kgf·cm)

- b) Reinstall the front brake hose with the **NEW** clip.
 c) Repeat the procedure on the opposite side.

NEW Replacement Parts

| Part Number | Part Name | Kit # | Qty |
|-------------|-----------|-------|-----|
| 90105-A0064 | Bolt | 2 | 3 |

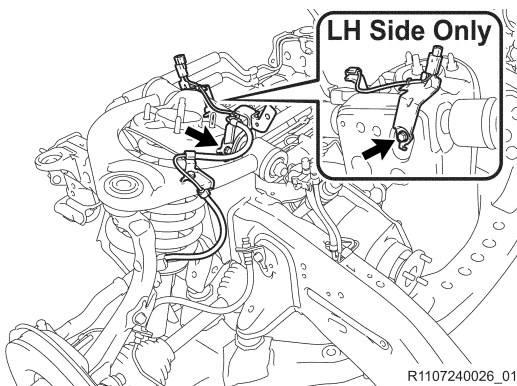

27. RECONNECT THE SKID CONTROL SENSOR WIRES

- a) Reinstall the skid control sensor wire with the 2 **NEW** bolts and torque to spec. (**LH Side Connects to the Frame**)

- b) Reinstall the skid control sensor wire with the **NEW** bolt and torque to spec. (**RH Side Connects to the Body**)

Torque Spec: 9 ft·lbs (12.5 N·m 127 kgf·cm)

NEW Replacement Parts

| Part Number | Part Description | Kit # | Quantity |
|----------------------------------|-----------------------------|-------|----------|
| 77285-34380 | Clamp, Fuel Tube, No.1 | 2 | 3 |
| 77289-26010 | Clamp, Fuel Tube, No.1 | 1 | 1 |
| 77285-34370 | Clamp, Fuel Tube, No.2 | 1 | 3 |
| 77296-0C010 or 77296-0C020 | Clamp, Fuel Tube, No.3 | 2 | 1 |
| 77412-34010 | Clamp, Fuel Tube, No.4** | NA* | 1 |
| 77412-34010 | | NA* | 2 |
| 77412-34010 | | NA* | 3 |
| 77413-34010 | Clamp, Fuel Tube, No.5 | 1 | 1 |
| 90105-A0179 | Bolt** | NA* | 2 |
| 90105-A0179 | | NA* | 3 |
| 90105-A0179 | | NA* | 4 |

* Individual Part(s)

** Only 1 part is used. The part number depending on the list

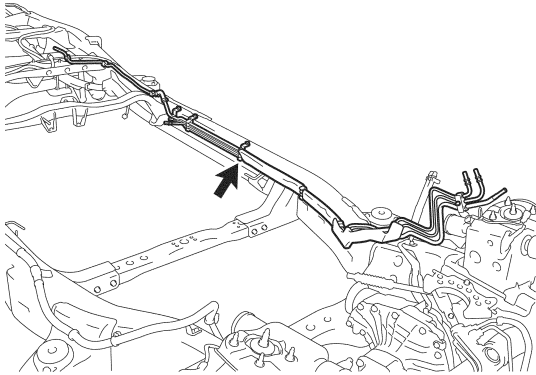

R1107300015

28. REINSTALL THE FUEL TUBES

- a) Reinstall the fuel tubes with the **NEW** clamps and **NEW** bolts, then torque to spec.

Torque Spec: 21 ft·lbs (29 N·m, 296 kgf·cm)

NOTE:

The number of clamps will differ depending on the vehicle spec.

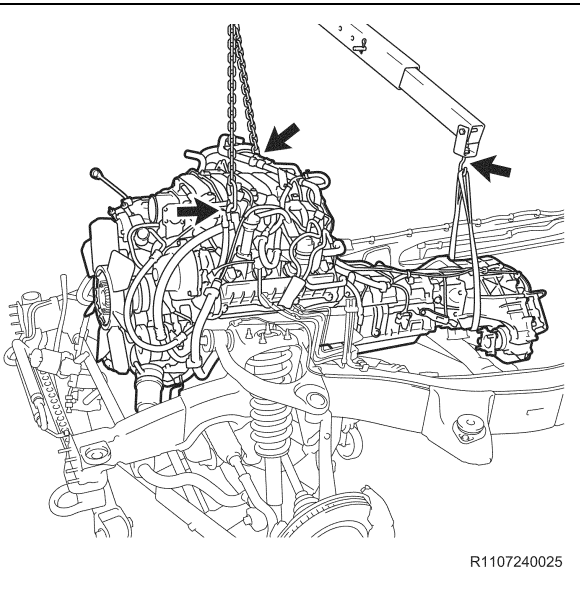

R1107240025

29. REINSTALL THE ENGINE AND TRANSMISSION ASSY

- a) Reinstall engine and transmission assy.

NOTE:

- When reinstalling the engine and transmission assy, **ALWAYS** use 2 engine hoists or mini cranes to lift it.
- **DO NOT** use 1 engine hoist or mini crane to lift the engine and transmission assy, as the unbalanced weight may lead to an accident or injury.
- **ONLY** use engine hoists or mini cranes that can properly support the weight of the engine and transmission assy.
- Carefully adjust the 2 engine hoists or mini cranes used so that the engine and transmission assy is properly balanced.

NEW Replacement Parts

| Part Number | Part Name | Kit # | Qty |
|-------------|-----------|-------|-----|
| 90119-A0224 | Bolt | 2 | 4 |

LH Side

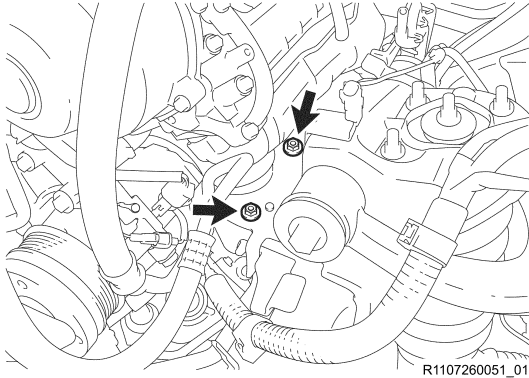

RH Side

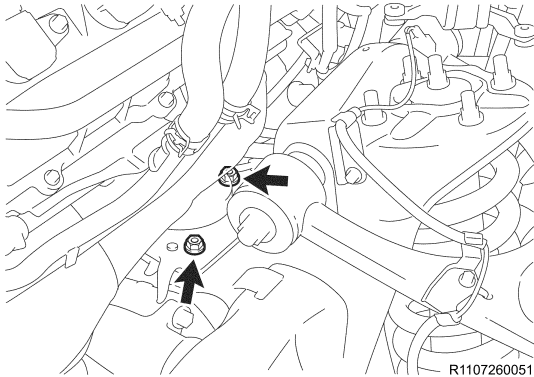

- b) Attach the engine mounts with the 4 **NEW** bolts and torque to spec.

Torque Spec: 58 ft·lbs (79 N·m, 806 kgf·cm)

NEW Replacement Parts

| Part Number | Part Name | Kit # | Qty |
|-------------|-----------|-------|-----|
| 90119-A0210 | Bolt | 2 | 4 |

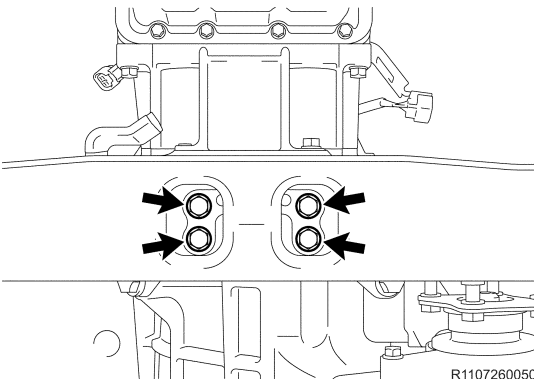

- c) Attach the transmission mount with 4 **NEW** bolts and torque to spec.

Torque Spec: 12 ft·lbs (16 N·m, 163 kgf·cm)

- d) Remove the bolt(s) and the engine hangers.
(1GR-FE, 3UR-FE Only)
- e) Reinstall the items/parts that were removed during the engine and transmission assy removal.

NEW Replacement Parts

| Part Number | Part Name | Kit # | Qty |
|-------------|--|-------|-----|
| 17176-0P010 | Gasket, Airsurge Tank To Intake Manifold | NA* | 1 |

* Individual Part(s)

30. REINSTALL THE INTAKE AIR SURGE TANK (1GR-FE ONLY)

- Install the **NEW** air surge tank to intake manifold gasket.
- Reinstall the intake air surge tank with the 4 bolts and the 2 nuts, then torque to spec.

Torque Spec: 21 ft·lbs (28 N·m, 286 kgf·cm)

- Reinstall the 3 surge tank stays with the 6 bolts and torque to spec.

Torque Spec: 15 ft·lbs (21 N·m, 214 kgf·cm)

- Reinstall the oil baffle plate with the bolt and torque to spec.

Torque Spec: 80 in·lbs (9.0 N·m, 92 kgf·cm)

- Reinstall the 2 water by-pass hoses.
- Reinstall the No.1 ventilation hose.
- Reinstall the 3 connectors and 4clamps.

31. REINSTALL THE POWER STEERING PUMP ASSY

- Reinstall the power steering vane pump with the 2 bolts and the nut (**2UZ-FE Only**) or the 2 bolts (**1GR-FE, 3UR-FE Only**), then torque to spec.

Torque Spec: 21 ft·lbs (28 N·m, 286 kgf·cm)

- Reconnect the clamp. (**3UR-FE Only**)
- Reconnect the connectors.
- Reinstall the drive belt.

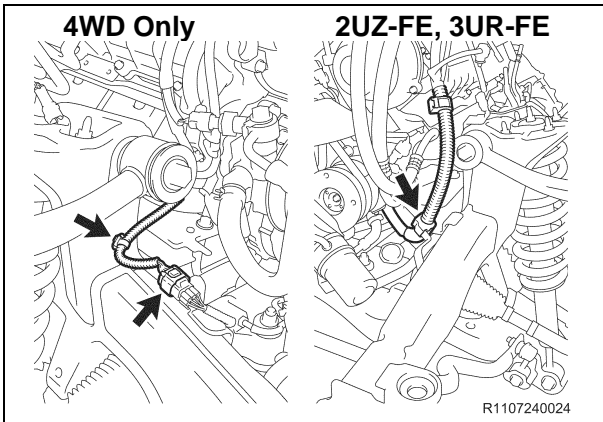

32. RECONNECT THE DIFFERENTIAL WIRE (4WD ONLY)

33. RECONNECT THE ENGINE WIRE (2UZ-FE, 3UR-FE ONLY)

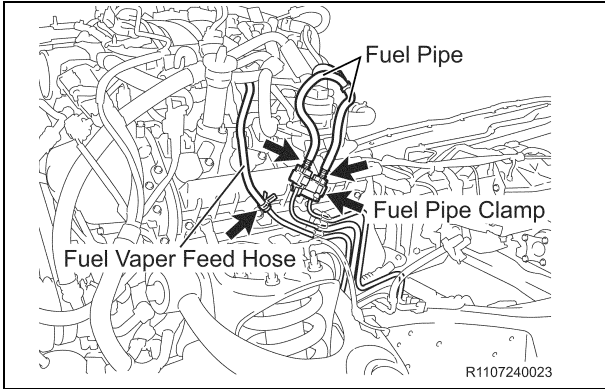

34. RECONNECT THE FUEL PIPES

- a) Reconnect the 2 fuel pipes.
- b) Reinstall the No.1 fuel pipe clamp.

35. RECONNECT THE FUEL VAPOR FEED HOSE ASSY

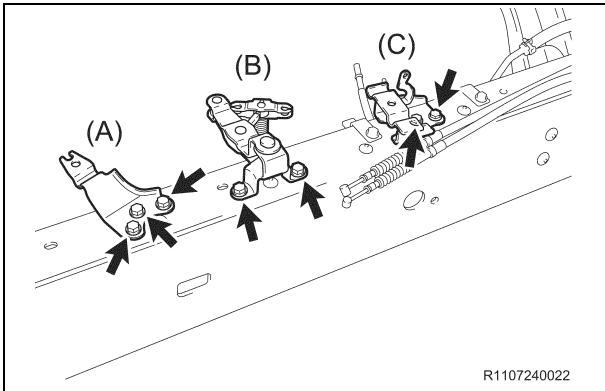

36. RECONNECT THE PARKING BRAKE SYSTEM

- a) Reconnect the cable support bracket with the 3 bolts and torque to spec (A).
- b) Reconnect the parking brake intermediate lever with the 2 bolts and torque to spec (B).
- c) Reconnect the No.2 cable support bracket with the 2 bolts and torque to spec (C).

Torque Spec: 14 ft·lbs (19 N·m, 194 kgf·cm)

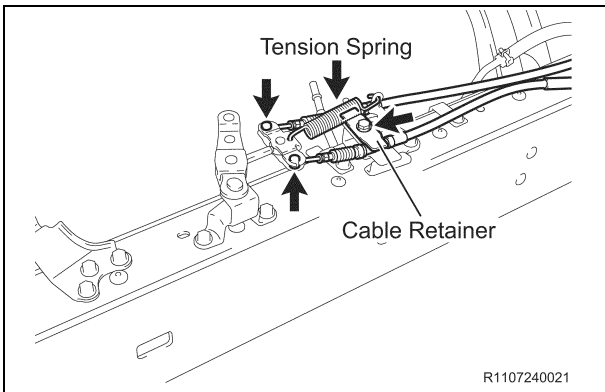

- d) Reconnect the 2 parking brake cables.
- e) Reinstall the tension spring.
- f) Reinstall the cable retainer with the bolt and torque to spec.

Torque Spec: 9 ft·lbs (12.5 N·m, 127 kgf·cm)

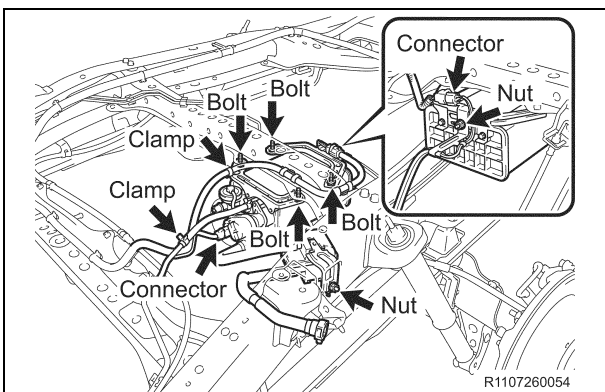

37. REINSTALL THE CHARCOAL CANISTER ASSY

- a) Reinstall the charcoal canister assy with the 4 bolts and 2 nuts, then torque to spec.

Torque Spec:
Bolt - 21 ft·lbs (29 N·m, 296 kgf·cm)
Nut - 9 ft·lbs (12.5 N·m, 127 kgf·cm)

- b) Reconnect the fuel hose, connector and clamp.

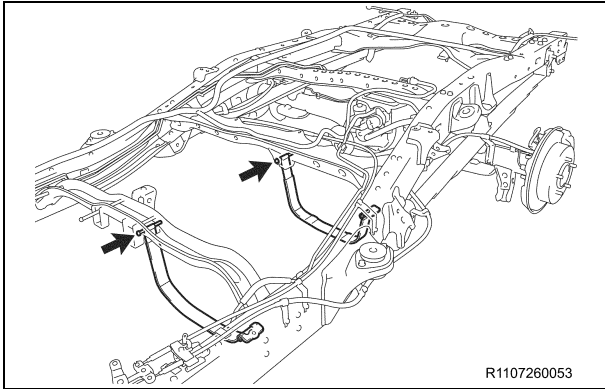

38. REINSTALL THE FUEL TANK STRAPS

- a) Reinstall the fuel tank straps with the 2 pins and 2 clips.

NEW Replacement Parts

| Part Number | Part Name | Kit # | Qty |
|-------------|------------------------------|-------|-----|
| 90119-A0077 | Bolt | 2 | 2 |
| 77272-0C030 | Support, Breather Tube, No.1 | 2 | 1 |

39. REINSTALL THE FUEL TANK ASSY

- a) Reinstall the fuel tank assy with the 2 **NEW** bolts and torque to spec.

Torque Spec: 30 ft·lbs (40 N·m, 408 kgf·cm)

- b) Reconnect the 2 fuel tubes.
- c) Reconnect the connector and clamps.
- d) Reconnect the **NEW** No.1 breather tube support and hose.

NEW Replacement Parts

| Part Number | Part Name | Kit # | Qty |
|-------------|-----------|-------|-----|
| 90080-11373 | Bolt | NA* | 2 |

* Individual Part(s)

40. REINSTALL THE No.1 FUEL TANK PROTECTOR ASSY (IF EQUIPPED)

- a) Reinstall the No.1 fuel tank protector with the 2 **NEW** bolts and the 2 nuts, then torque to spec.

Torque Spec: Bolt - 21 ft·lbs (29 N·m, 296 kgf·cm)
Nut - 15 ft·lbs (20 N·m, 204 kgf·cm)

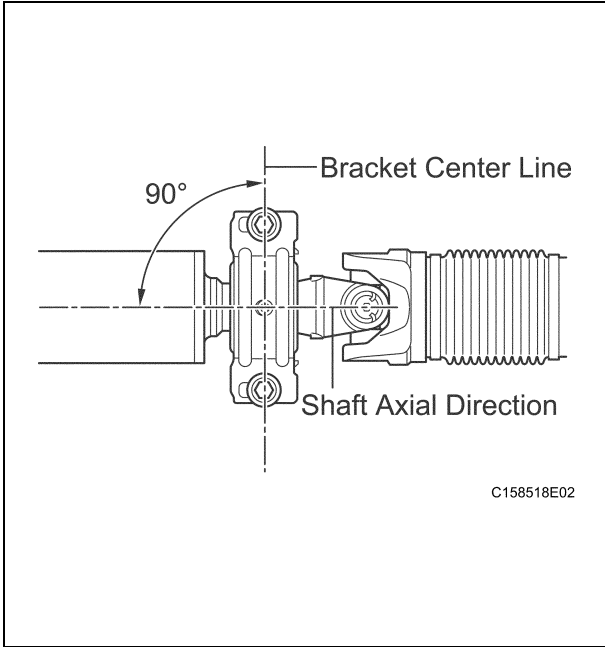

41. REINSTALL THE REAR PROPELLER SHAFT ASSY

- a) Remove the SST. **(2WD Only)**
- b) Referencing the matchmarks, reinstall the propeller shaft assy to the transmission / transfer case.
- c) Reinstall the 4 nuts and torque to spec. **(4WD Only)**

Torque Spec: 52 ft·lbs (70 N·m, 714 kgf·cm)

- d) Reinstall the center support bearing to the frame as shown in the illustration with 2 washer and 2 bolts, then torque to spec. **(3-Joint Type Only)**

Torque Spec: 30 ft·lbs (40.2 N·m, 410 kgf·cm)

- e) Referencing the matchmarks, reinstall the propeller shaft assy to the rear differential with 4 bolts, and 4 nuts, then torque to spec.

Torque Spec: 52 ft·lbs (70 N·m, 714 kgf·cm)

42. REINSTALL THE FRONT PROPELLER SHAFT ASSY

- a) Referencing the matchmarks, install the front propeller shaft assy to the transfer case and the front differential with 8 nuts and 8 washers, then torque to spec.

Torque Spec: 59 ft·lbs (80.3 N·m, 819 kgf·cm)

| NEW Replacement Parts | | | |
|-----------------------|-----------|-------|-----|
| Part Number | Part Name | Kit # | Qty |
| 90119-A0151 | Bolt | 4 | 2 |

43. REINSTALL THE PROPELLER SHAFT HEAT INSULATOR (4WD ONLY)

- a) Reinstall the propeller shaft heat insulator with the 2 **NEW** bolts and torque to spec.

Torque Spec: 12 ft·lbs (15.7 N·m, 160 kgf·cm)

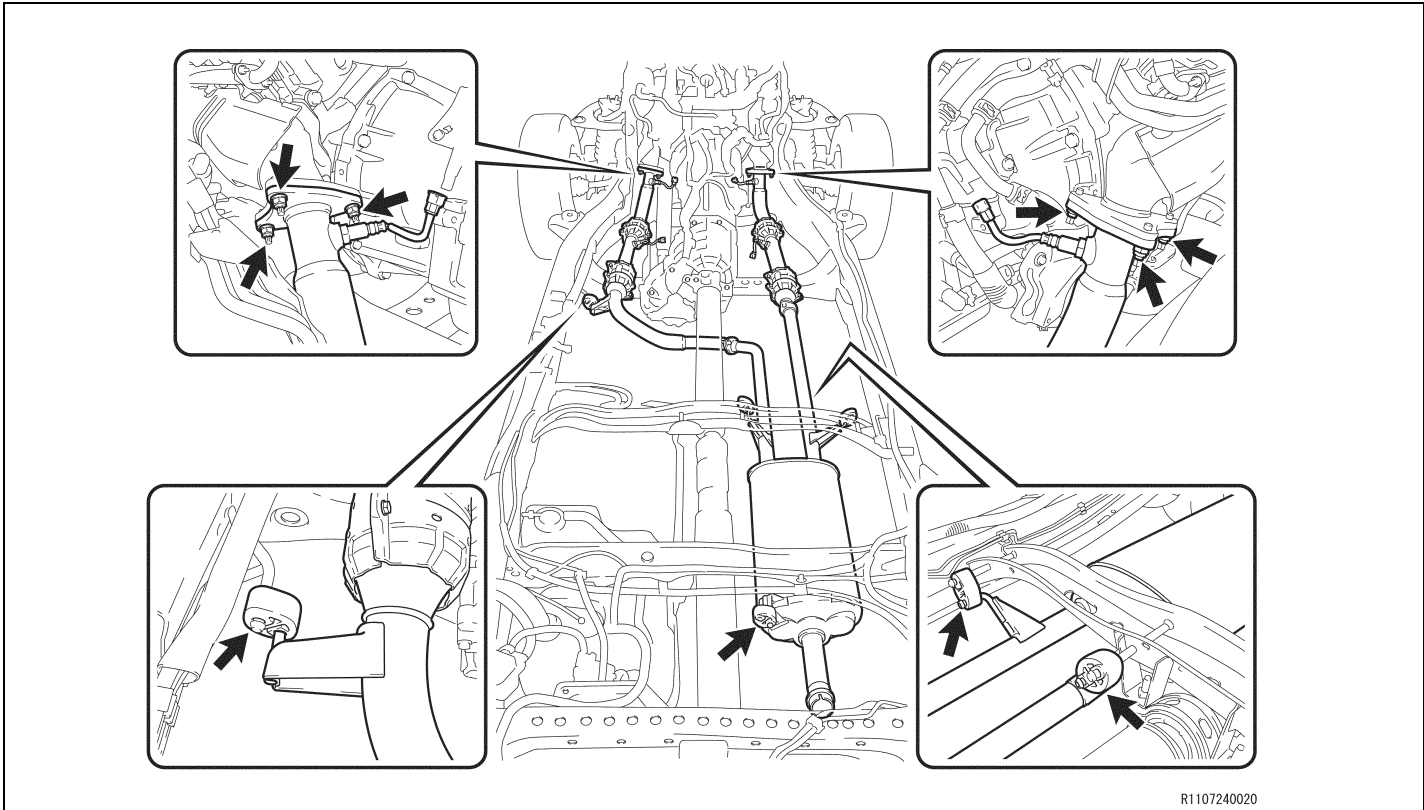

R1107240020

NEW Replacement Parts

| Part Number | Part Name | Kit # | Qty |
|-------------|--|-------|-----|
| 90917-A6002 | Gasket, Exhaust Pipe | 2 | 2 |
| 90126-A0011 | Bolt, Stud (For Exhaust Manifold, RH) 3UR# | NA* | 3 |
| 90126-A0011 | Bolt, Stud (For Exhaust Manifold, LH) 3UR# | NA* | 3 |
| 90126-A0011 | Bolt, Stud (For Manifold To Exhaust Pipe) | NA* | 6 |
| 90080-17187 | Nut | 2 | 6 |

* Individual Part(s)

44. REINSTALL THE EXHAUST SYSTEM

- a) Install the 2 **NEW** exhaust pipe gaskets.
- b) Reinstall the exhaust pipe and 4 exhaust pipe supports.
- c) Install the 6 **NEW** nuts and torque to spec.

Torque Spec: 40 ft·lbs (54.3 N·m, 554 kgf·cm)

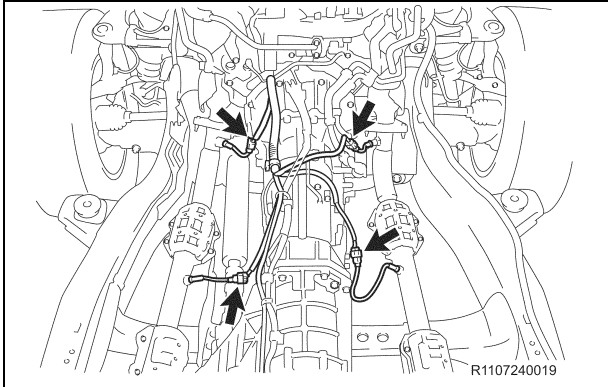

R1107240019

45. RECONNECT THE OXYGEN SENSOR CONNECTORS

- a) Reconnect the 4 oxygen sensor connectors.

NEW Replacement Parts

| Part Number | Part Name | Kit # | Qty |
|-------------|--------------------------------|-------|-----|
| 90917-06085 | Gasket, Exhaust Pipe, Center** | NA* | 1 |
| 90917-06093 | | NA* | 1 |
| 90119-A0380 | Bolt | 2 | 1 |
| 90080-46263 | Clamp** | NA* | 1 |
| 90461-15017 | | NA* | 1 |

* Individual Part(s)

** Only 1 part used. The part number depending on the list.

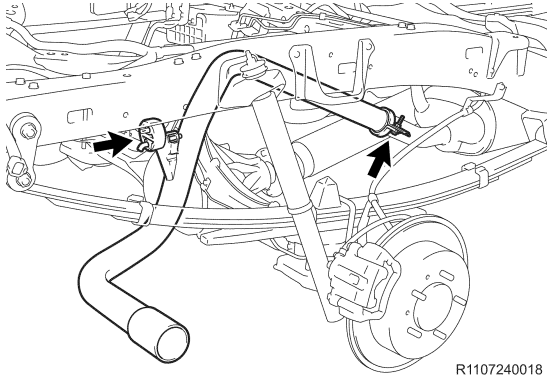

46. REINSTALL THE EXHAUST TAIL PIPE ASSY

- Install the **NEW** exhaust pipe gasket.
- Reinstall the exhaust tail pipe and exhaust pipe support.
- Install the **NEW** bolt and **NEW** clamp, then torque to spec.

Torque Spec: 24 ft·lbs (32 N·m, 326 kgf·cm)

47. REINSTALL THE FOLLOWING PARTS

- Spare Tire
- Wheels

48. REMOVE THE FRAME FROM THE LIFT

- Remove the ratcheting tie down strap from the frame.
- Lower the frame to the ground.

I. REINSTALL THE CAB BODY ASSY

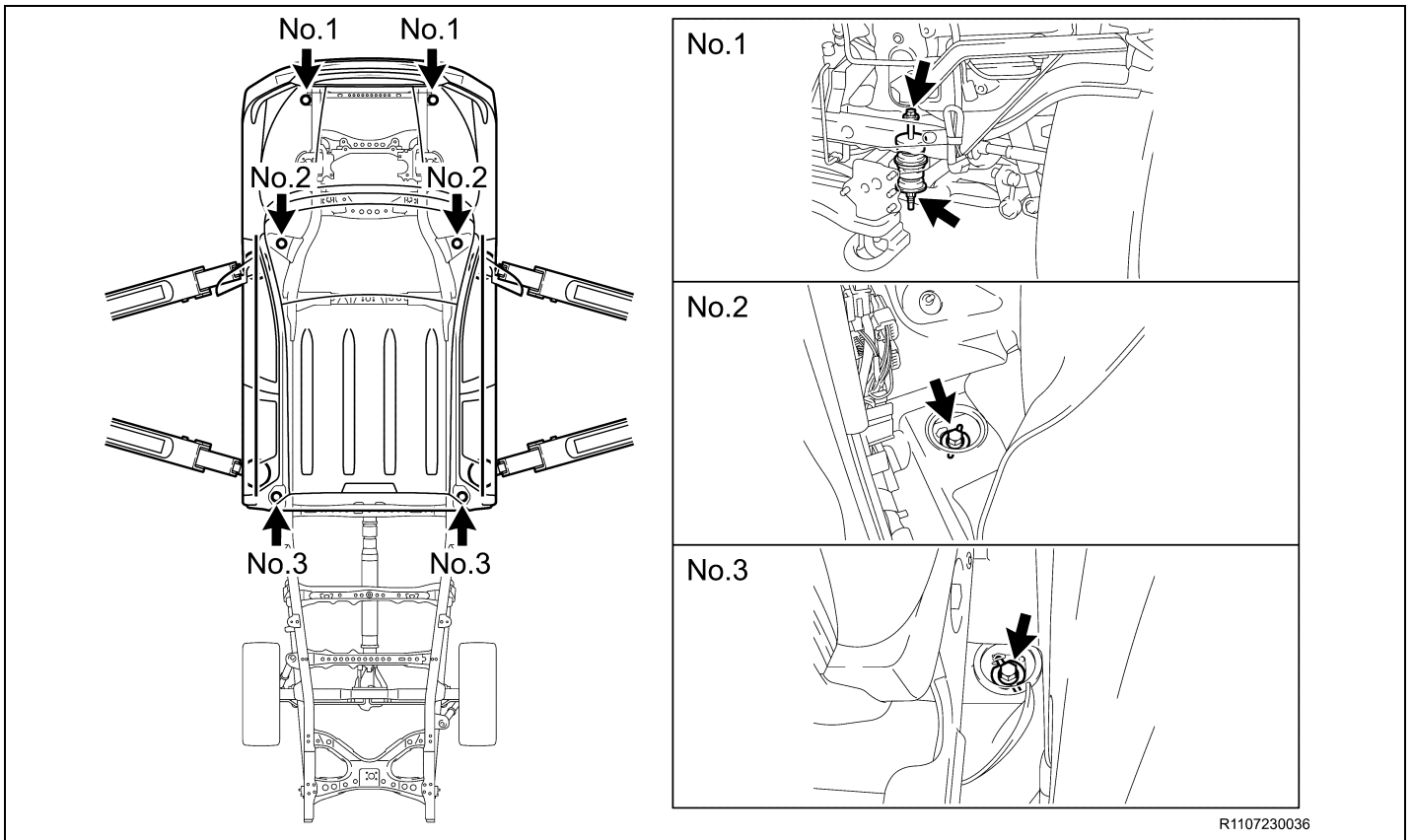

1. REINSTALL THE CAB BODY ASSY

- Raise the cab assy high enough so that the top of the engine clears the lowest point of the cab.
- Push the frame under the cab assy.
- Lower the cab assy slowly, making sure it does not interfere with anything.
- Adjust the vehicle's frame as needed to align the cab mounts with the cab assy bolts.
- Once the cab assy is set on the mounts, secure it to the frame with 6 bolts, 6 nuts, 4 washers and 2 No.1 lower cab mounting cushion sub-assy, then torque to spec.

Torque Spec: 40 ft·lbs (54 N·m, 551 kgf·cm)

NOTE:

- DO NOT** work directly underneath the vehicle when pushing the frame under the cab assy.
- Slowly** lower the cab body assy while making sure that the wire harness, steering shaft and hoses do not interfere.
- With 2 to 3 people checking for interference, **slowly** lower the cab body assy to the frame.

NEW Replacement Parts

| Part Number | Part Name | Kit # | Qty |
|-------------|---------------------------|-------|-----|
| 90412-10268 | Way (For Rear Brake Tube) | 1 | 1 |
| 90119-A0184 | Bolt | 2 | 1 |

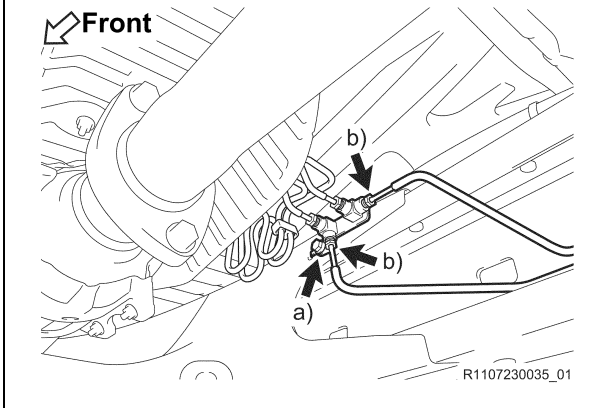

2. RECONNECT THE REAR BRAKE TUBES

- a) Reconnect the rear brake tubes with the **NEW** bolt and torque to spec.

Torque Spec: 23 ft·lbs (31 N·m, 316 kgf·cm)

- b) Reconnect the 2 rear brake tubes and torque to spec.

Torque Spec: 11 ft·lbs (15.2 N·m, 155 kgf·cm)

NEW Replacement Parts

| Part Number | Part Name | Kit # | Qty |
|-------------|-----------|-------|-----|
| 90080-17229 | Nut | NA* | 1 |

* Individual Part(s)

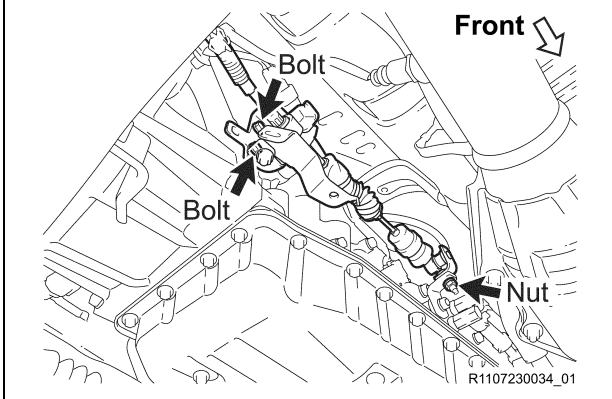

3. RECONNECT THE TRANSMISSION CONTROL CABLE

- a) Reconnect the shift cable with the 2 bolts and **NEW** nut, then torque to spec.

Torque Spec:

Bolt - 9 ft·lbs (12 N·m, 122 kgf·cm)

Nut - 10 ft·lbf (14 N·m, 143 kgf·cm)

- b) Reconnect the ground wire with the bolt and torque to spec.

Torque Spec: 73 in·lbs (8.3 N·m, 85 kgf·cm)

- c) Reconnect the 3 clamps.

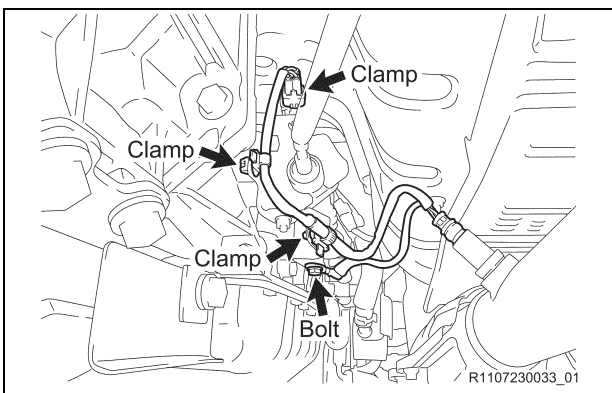

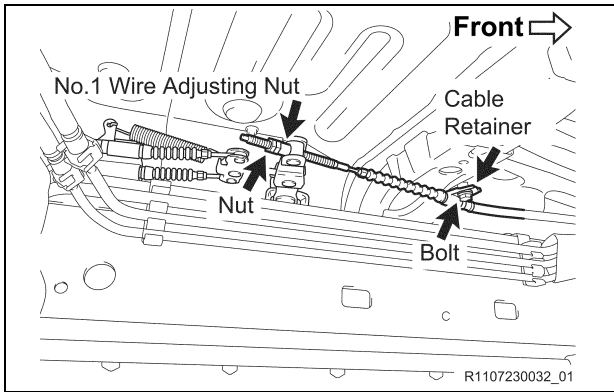

4. RECONNECT THE No.1 PARKING BRAKE CABLE

- a) Reconnect the No.1 parking brake cable.
- b) Reinstall the cable retainer with the bolt and torque to spec.

Torque Spec: Bolt - 9 ft-lbs (12.5 N·m, 127 kgf-cm)

- c) Reinstall the No.1 wire adjusting nut and nut, then torque to spec.

Torque Spec: Nut - 11 ft-lbs (15 N·m, 153 kgf-cm)

5. REMOVE THE FRONT WHEELS

NEW Replacement Parts

| Part Number | Part Name | Kit # | Qty |
|-------------|-----------|-------|-----|
| 90080-11555 | Bolt | 2 | 1 |

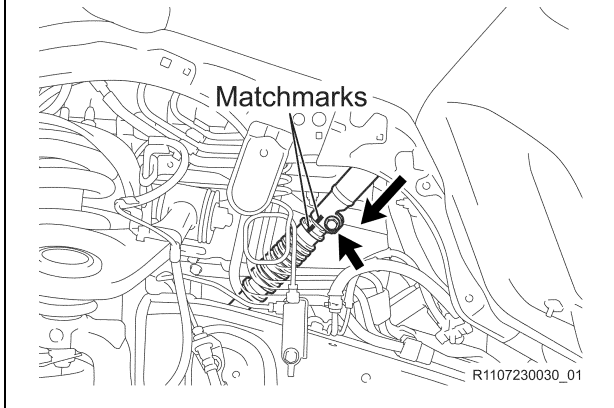

6. RECONNECT THE No.2 STEERING INTERMEDIATE SHAFT

- a) Make sure the front wheels are in a straight-ahead position and the steering wheel is centered.
- b) Referencing the matchmarks, connect the No.2 intermediate shaft to the intermediate shaft with the **NEW** bolt.
- c) Torque bolt to spec.

Torque Spec: 26 ft-lbs (35 N·m, 357 kgf-cm)

- d) Disconnect the seat belt that is holding the steering wheel.

NEW Replacement Parts

| Part Number | Part Name | Kit # | Qty |
|-------------|-----------|-------|-----|
| 90464-00897 | Clamp | 4 | 1 |

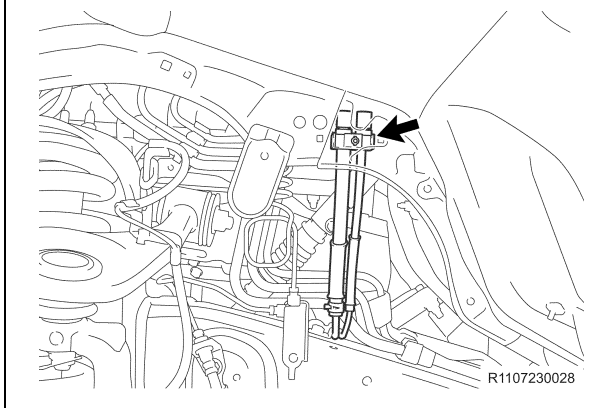

7. RECONNECT THE FRONT DIFFERENTIAL VACUUM HOSE (4WD ONLY)

- a) Reconnect the **NEW** clamp and vacuum hose.

NEW Replacement Parts

| Part Number | Part Description | Kit # | Quantity |
|----------------------------------|-------------------------------------|-------|----------|
| 90412-10266 | Way, No.1 (For Front Brake Tube) | 1 | 1 |
| 90412-10267 | Way, No.2 (For Front Brake Tube) | 1 | 1 |
| 47314-0C020 | Tube, Front Brake, No.4 | 2 | 1 |
| 47315-0C030 or 47315-0C031 | Tube, Front Brake, No.5 | 2 | 1 |
| 90119-A0169 | Bolt | 2 | 2 |

LH Side

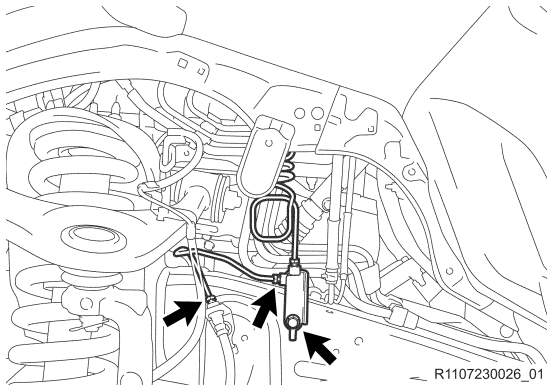

RH Side

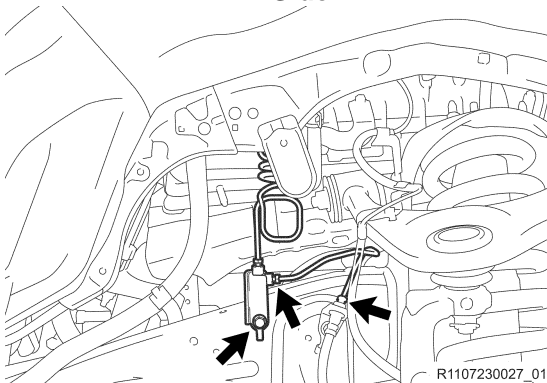

8. RECONNECT THE FRONT BRAKE TUBES

- Reconnect the front brake tube with the **NEW** bolt and torque to spec.

Torque Spec: 23 ft·lbs (31 N·m, 316 kgf·cm)

- Temporarily install the **NEW** front brake tube.
- Torque the front **NEW** brake tube to spec.

Torque Spec: 11 ft·lbs (15.2 N·m, 155 kgf·cm)

- Repeat the procedure on the opposite side.

NEW Replacement Parts

| Part Number | Part Name | Kit # | Qty |
|-------------|------------------------------------|-------|-----|
| 90080-46327 | Clip (For Front Fender Apron Seal) | 2 | 22 |

LH Side

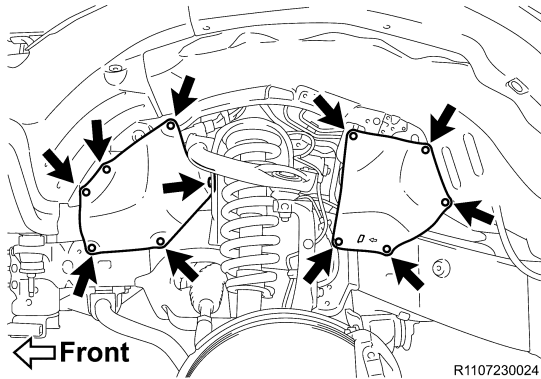

RH Side

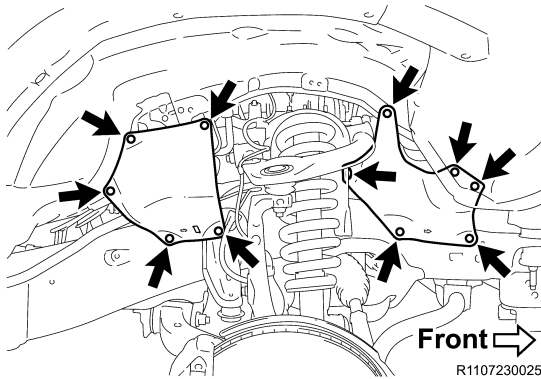

9. REINSTALL THE FRONT FENDER APRON SEALS

- Reinstall the left side 2 front fender apron seals LH / RH with the 11 **NEW** clips.
- Reinstall the right side 2 front fender apron seals LH / RH with the 11 **NEW** clips.

10. RECONNECT THE VANE PUMP OIL RESERVOIR ASSY

- Reconnect the vane pump oil reservoir assy with the 3 bolts and torque to spec.

Torque Spec: 71 in·lbs (8.0 N·m, 82 kgf·cm)

- Reconnect the windshield washer jar assy with the 3 bolts and torque to spec.

Torque Spec: 31 in·lbs (3.5 N·m, 36 kgf·cm)

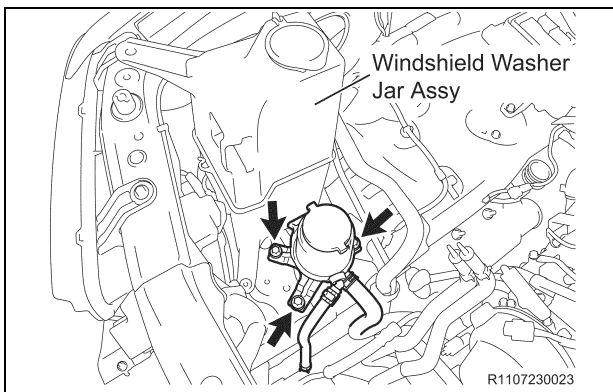

NEW Replacement Parts

| Part Number | Part Name | Kit # | Qty |
|-------------|-----------------------------------|-------|-----|
| 16492-21050 | Packing (For Radiator Drain Cock) | 2 | 1 |

11. REINSTALL THE FOLLOWING PARTS

- Radiator Assy
 - Install the **NEW** radiator drain cock packing.
 - Reinstall the radiator assy with the 4 bolts and torque to spec.
 - **Torque Spec: 13 ft·lbs (18 N·m, 184 kgf·cm)**
- Fan Shroud
 - Reinstall the fan shroud with the 2 bolts and torque to spec.
 - **Torque Spec: 58 in·lbs (6.5 N·m, 66 kgf·cm)**
- Radiator Outlet Hose
- Radiator Inlet Hose

NEW Replacement Parts

| Part Number | Part Name | Kit # | Qty |
|-------------|-----------|-------|-----|
| 90099-14120 | O-Ring | 1 | 1 |

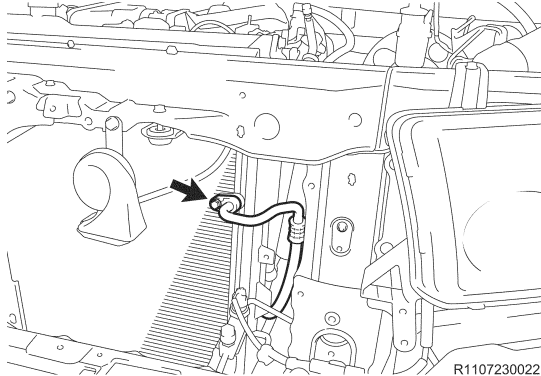

12. RECONNECT THE No.1 COOLER REFRIGERANT DISCHARGE HOSE

- a) Install a **NEW** o-ring to the A/C discharge hose.
- b) Reconnect the A/C discharge hose with the bolt and torque to spec.

Torque Spec: 87 in·lbs (9.8 N·m, 100 kgf·cm)

13. REINSTALL THE FOLLOWING PARTS

- Radiator Side Deflector RH (*If Equipped*)
- Radiator Side Deflector LH

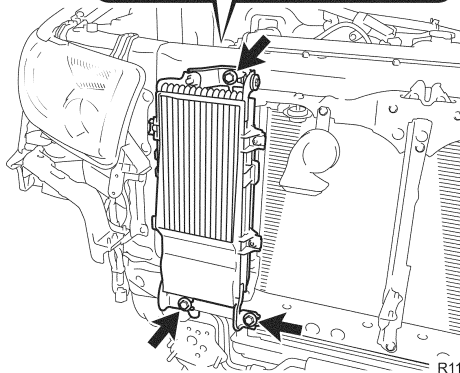
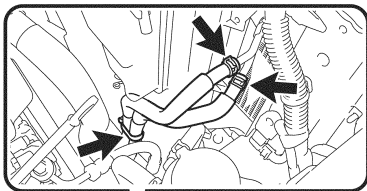

14. REINSTALL THE OIL COOLER (AIR OIL COOLER EQUIPPED VEHICLES ONLY)

- a) Reinstall the oil cooler with the 3 bolts and torque to spec.

Torque Spec: 10 ft·lbs (14 N·m, 143 kgf·cm)

- b) Reconnect the No.1 oil cooler inlet hose and No.1 oil cooler outlet hose.
- c) Reconnect the clamp.

NEW Replacement Parts

| Part Number | Part Name | Kit # | Qty |
|-------------|-----------|-------|-----|
| 90179-06178 | Nut | 1 | 6 |

15. REINSTALL THE UPPER CENTER FRONT BUMPER RETAINER (AIR OIL COOLER EQUIPPED VEHICLES ONLY)

- a) Reinstall the front bumper retainer upper center with the 6 **NEW** nuts and torque to spec.
Torque Spec: 48 in·lbs (5.4 N·m, 55 kgf·cm)

1GR-FE

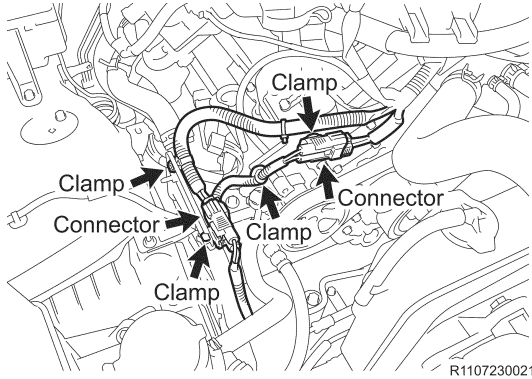

16. RECONNECT THE AIR PUMP HARNESS

- a) Reconnect the 2 connectors and 4 clamps.
(1GR-FE)
- b) Reconnect the connector and 2 clamps.
(2UZ-FE)
- c) Reconnect the 2 connectors and 3 clamps.
(3UR-FE)

2UZ-FE

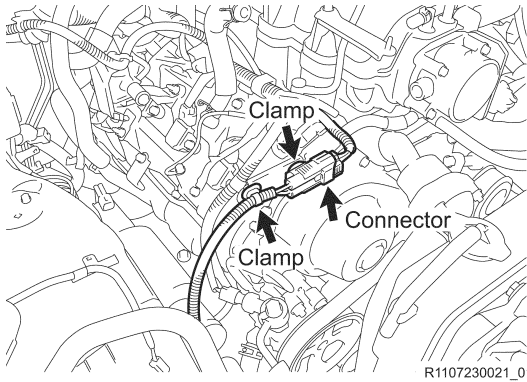

3UR-FE

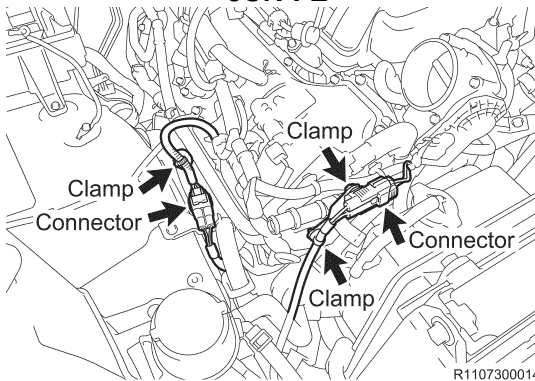

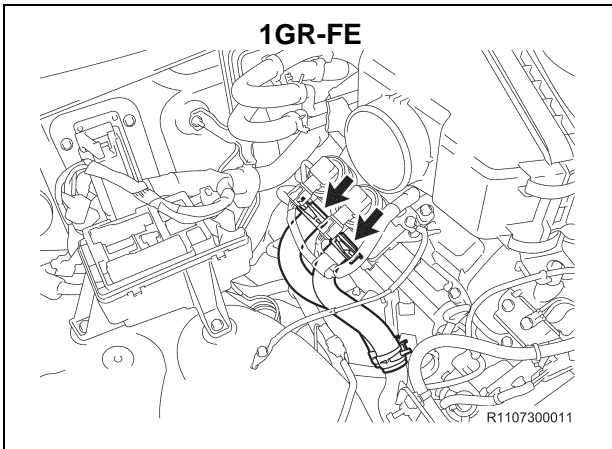

17. RECONNECT THE AIR INJECTION SYSTEM HOSES

- a) Reconnect the No.5 hose and No.4 hose. **(1GR-FE)**
- b) Reconnect the No.2 Hose and clamp. **(2UZ-FE)**
- c) Reconnect the No.2 hose and No.3 hose. **(3UR-FE)**

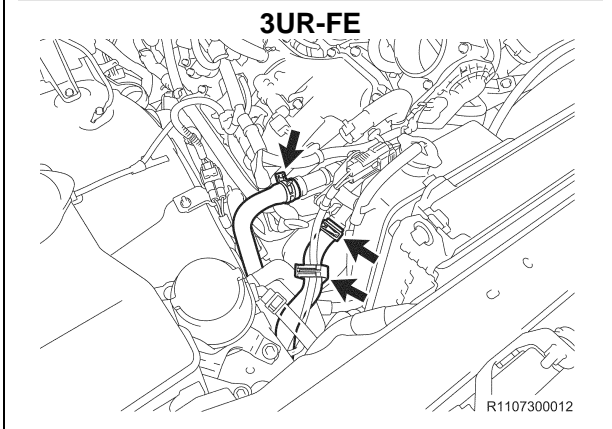
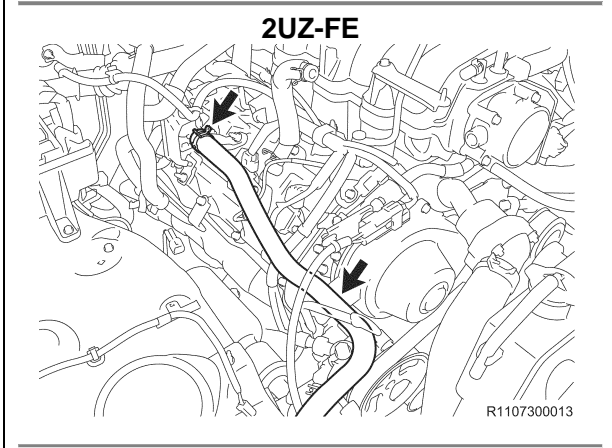

18. RECONNECT THE INLET HEATER HOSE AND OUTLET HEATER HOSE, ENGINE SIDE

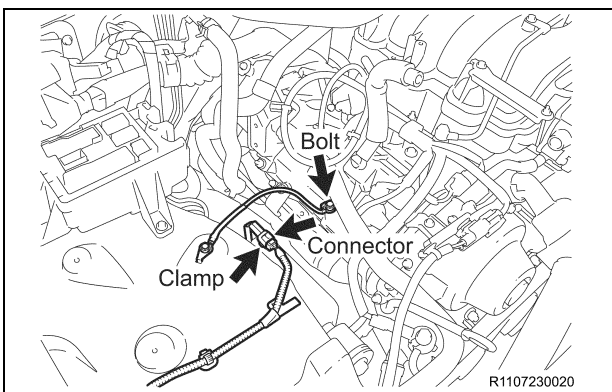

19. RECONNECT THE ENGINE WIRE HARNESS (RH SIDE)

- a) Reconnect the ground wire with the bolt and torque to spec.
- Torque Spec: 73 in·lbs (8.3 N·m, 85 kgf·cm)**
- b) Reconnect the skid control sensor connector and clamp.

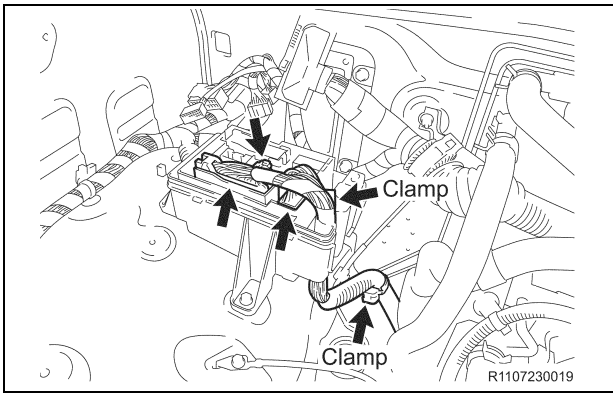

c) Reconnect the 2 clamps and 3 connectors.

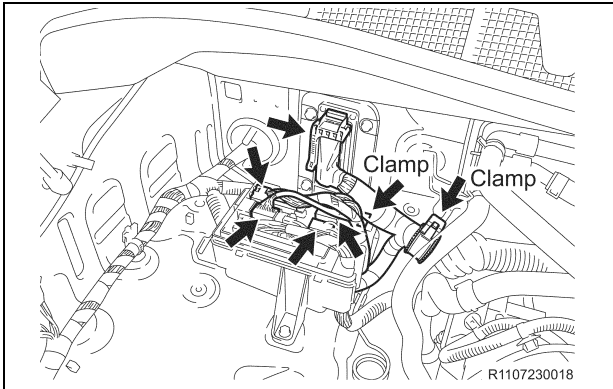

d) Reconnect the 2 clamps and 5 connectors.
e) Reinstall the connector holder block cover upper.

NEW Replacement Parts

| Part Number | Part Name | Kit # | Qty |
|-------------|-----------|-------|-----|
| 90069-08009 | O-Ring | 2 | 1 |

20. RECONNECT THE VACUUM HOSE ASSY

a) Reconnect the vacuum hose assy.

21. RECONNECT THE No.1 COOLER REFRIGERANT SUCTION HOSE

a) Install a **NEW** o-ring to the A/C suction hose.
b) Reconnect the A/C suction hose and torque to spec.

Torque Spec: 87 in·lbs (9.8 N·m, 100 kgf·cm)

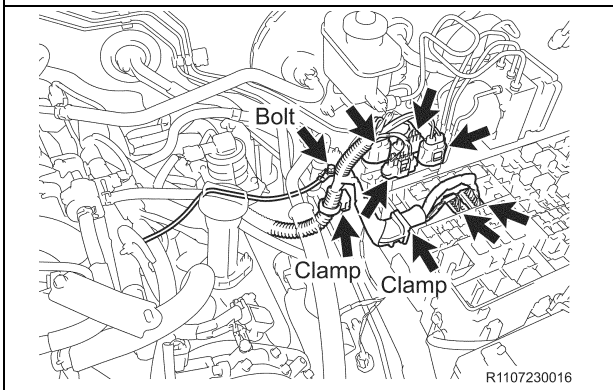

22. RECONNECT THE ENGINE WIRE HARNESS (LH SIDE)

a) Reconnect the ground wire with the bolt and torque to spec.

Torque Spec: 73 in·lbs (8.3 N·m, 85 kgf·cm)

b) Reconnect the 2 clamps and 6 connectors.

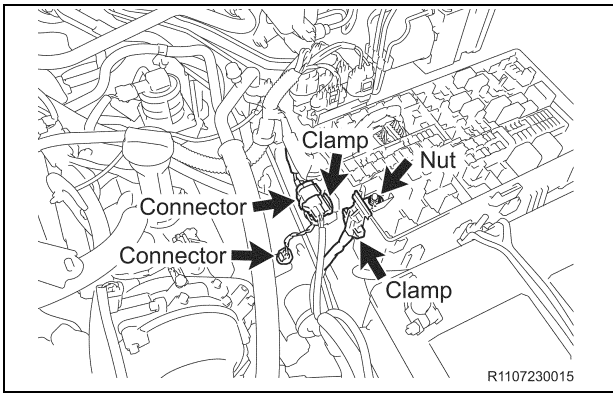

- c) Reconnect the (+) positive battery cable with the nut and torque to spec.

Torque Spec: 7 ft·lbs (10 N·m, 102 kgf·cm)

- d) Reconnect the clamp and 2 connectors.
- e) Reinstall the No.1 relay block cover.

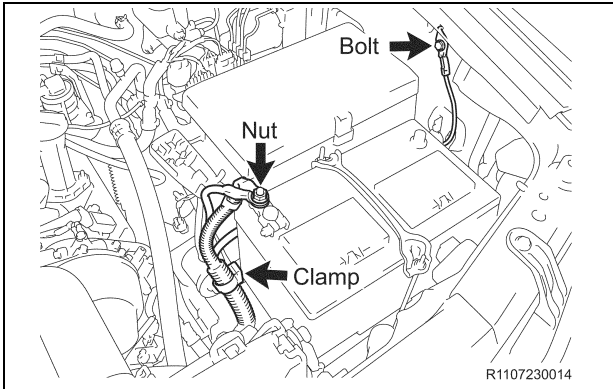

- f) Reconnect the clamp.

- g) Reconnect the ground wire with the bolt and torque to spec.

Torque Spec: 73 in·lbs (8.3 N·m, 85 kgf·cm)

- h) Reconnect the 2 positive (+) battery cables with the nut and torque to spec.

Torque Spec: 9 ft·lbs (12.7 N·m, 130 kgf·cm)

NEW Replacement Parts

| Part Number | Part Name | Kit # | Qty |
|-------------|-----------|-------|-----|
| 90178-A0044 | Nut | 2 | 8 |
| 90178-A0067 | Nut | 2 | 6 |
| 90189-06236 | Clip | NA* | 4 |
| 90080-11717 | Bolt | NA* | 16 |

* Individual Part(s)

23. REINSTALL THE FOLLOWING PARTS

- Air Cleaner Hose and Air Cleaner Assy
(1GR-FE Only)
 - **Torque Spec:**
Air Cleaner Assy - 71 in·lbs (8.0 N·m, 82 kgf·cm)
Air Cleaner Hose - 66 in·lbs (7.5 N·m, 76 kgf·cm)
- Air Cleaner Hose and Air Cleaner Assy
(2UZ-FE, 3UR-FE Only)
 - **Torque Spec: 44 in·lbs (5.0 N·m, 51 kgf·cm)**
- Throttle Body Cover Sub- Assy **(2UZ-FE Only)**
 - **Torque Spec: 66 in·lbs (7.5 N·m, 76 kgf·cm)**
- V-Bank Cover Sub- Assy **(1GR-FE, 3UR-FE Only)**
 - **Torque Spec: 66 in·lbs (7.5 N·m, 76 kgf·cm)**
(1GR-FE Only)
- Front Fender Mudguard LH/RH **(If Equipped)**
- No.2 Front Bumper Extension Sub-Assy LH/RH
 - Reinstall the No.2 front bumper extension Sub-Assy with 8 **NEW** nuts and torque to spec.
 - **Torque Spec: 43 ft·lbs (58 N·m, 591 kgf·cm)**
- Front Bumper Reinforcement Sub-Assy
 - Reinstall the front bumper reinforcement Sub-Assy with 6 **NEW** nuts and torque to spec.
 - **Torque Spec: 52 ft·lbs (71 N·m, 724 kgf·cm)**
- Front Bumper Assy
(Steel Bumper Equipped Vehicles Only)
 - Reinstall the front bumper bar with the 8 bolts and 4 **NEW** clips, then torque to spec.
 - **Torque Spec: Bolt - 24 ft·lbs (32 N·m, 326 kgf·cm)**
 - Reinstall the front bumper cover with the 16 **NEW** bolts, 10 clips and 2 screws.
- Front Bumper Cover Assy
(Resin Bumper Equipped Vehicles Only)
 - Reinstall with the 6 screws and 16 clips.
- Front Fender Splash Shield Sub-Assy LH/RH
- Front End Panel LH/RH
- Front Wheels

24. REINSTALL THE FOLLOWING PARTS

- Lower LH Quarter Trim Panel Assy **(Regular Cab Only)**
- Front Seat Outer Belt Assy LH **(Regular Cab Only)**
 - Reconnect the front seat outer belt assy LH.
 - **Torque Spec: 31 ft·lbs (42 N·m, 428 kgf·cm)**
- Upper Back Panel Garnish **(Regular Cab Only)**
- Luggage Compartment Box LH **(Regular Cab Only)**
- Floor Carpet is returned **(Double Cab Only)**
- Back Panel Trim LH/RH **(Crewmax Only)**
- No.1 w/ Box Speaker Assy **(If Equipped)**
- Jack and Tool (Standard Tool)
- No.2 Dash Panel Insulator Pad
- No.3 Dash Panel Insulator Pad
- Cowl Side Trim Board LH/RH
- Front Door Scuff Plate LH/RH

J. REINSTALL THE REAR BED ASSY

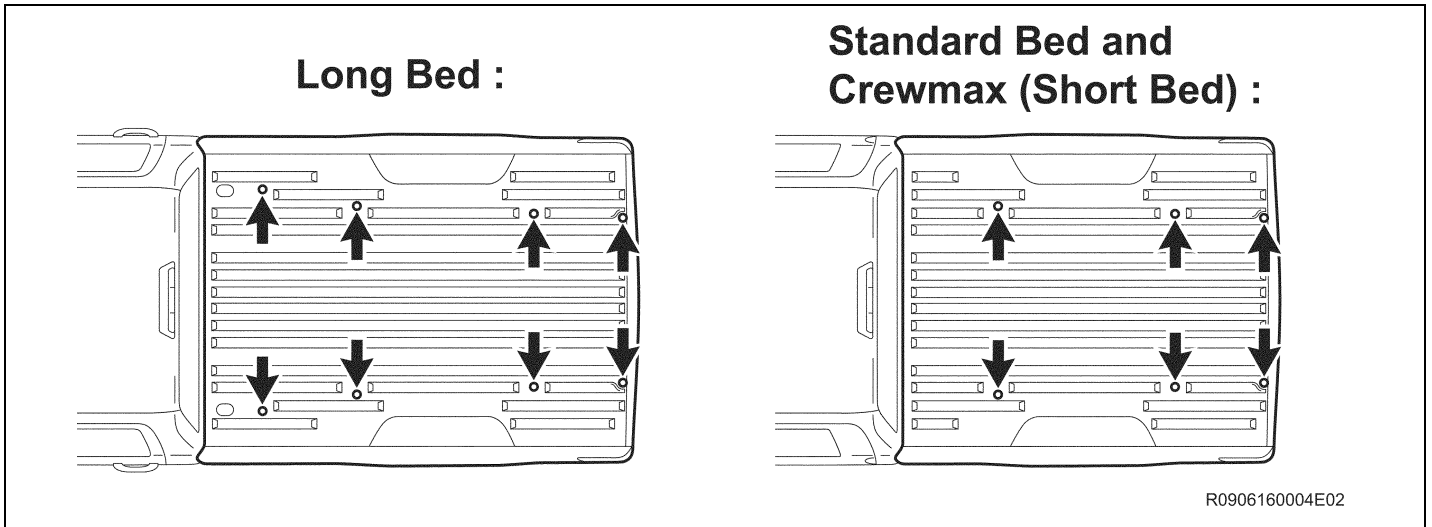

1. REINSTALL THE REAR BED ASSY

- a) Using a Torx® T55H Tamper Resistant Socket, reinstall the rear bed assy Torx® bolts and torque to spec.
- Long Bed: 8 Torx® bolts
 - Standard Bed and Crewmax (Short Bed): 6 Torx® bolts

Torque Spec: 44 ft·lbs (66 N·m, 673 kgf·cm)

NOTE:

- Use 4 or more people to install the rear bed assy from the frame.
- Evenly support the rear bed assy when reinstalling it.
- Be careful not to damage or hit the fuel inlet pipe when reinstalling the rear bed assy.

NEW Replacement Parts

| Part Number | Part Name | Kit # | Qty |
|-------------|-----------|-------|-----|
| 90178-A0049 | Nut | 2 | 2 |

R1107230012

2. REINSTALL THE FUEL TANK INLET PIPE SUB-ASSY

- a) Reinstall the fuel inlet pipe sub-assy with the 2 **NEW** nuts and torque to spec.

Torque Spec: 15 ft·lbs (20 N·m, 204 kgf·cm)

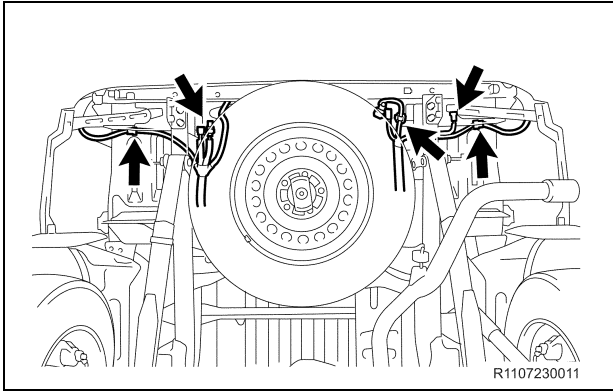

3. RECONNECT THE FRAME WIRE HARNESS

- a) Reconnect the clamps, connectors and the frame wire harness to the rear bed assy.

NOTE:

- The number of connectors will differ depending on the vehicle spec.
- Use new clamps if the original ones are damaged.

NEW Replacement Parts

| Part Number | Part Name | Kit # | Qty |
|-------------|-------------------------|-------|-----|
| 90119-A0219 | Bolt (w/o Towing Hitch) | NA* | 4 |
| 90119-A0219 | Bolt (w/ Towing Hitch) | NA* | 10 |
| 90119-A0271 | Bolt (w/o Towing Hitch) | NA* | 4 |
| 90119-A0271 | Bolt (w/ Towing Hitch) | NA* | 2 |

* Individual Part(s)

4. REINSTALL THE FOLLOWING PARTS

- No.1 Rear Wheel House Liner LH
- Fuel Filler Opening Lid Sub- Assy
- Side Step Assy LH/RH (*If Equipped*)
- Rear Bumper Assy
 - Reinstall the rear bumper assy with the 12 **NEW** bolts and torque to spec.
(Trailer Hitch Equipped Vehicles Only)
 - Reinstall the rear bumper assy with the 8 **NEW** bolts and torque to spec.
 - **Torque Spec: 113 ft·lbs (153 N·m, 1560 kgf·cm)**
- Rear Quarter panel Mudguard LH/RH (*If Equipped*)
- No.3 Frame Wire
- License Plate Light Assy LH/RH

K. FINAL ASSEMBLY

1. REINSTALL THE NEGATIVE (-) BATTERY TERMINAL

NEW Replacement Parts

| Part Number | Part Name | Kit # | Qty |
|-------------|--|-------|-----|
| 12157-10010 | Gasket, Front Differential Filler Plug | 3 | 1 |
| 90430-24003 | Gasket (For Front Differential Drain Plug) | 3 | 1 |

2. REFILL THE FOLLOWING FLUIDS

- Brake Fluid
 - Remove the brake tubes from the master cylinder.
 - Refill with Toyota Dot 3 Brake Fluid.
 - Bleed the master cylinder.
 - Reinstall the brake tubes to the master cylinder and torque to spec.
 - **Torque Spec: 11 ft-lbs (15.2 N·m, 155 kgf·cm)**
 - Refill with Toyota Dot 3 Brake Fluid.
 - Bleed the brake system at each wheel and torque the bleeder screws to spec.
 - **Torque Spec: 8 ft-lbs (11 N·m, 112 kgf·cm)**
- Coolant
 - Refill with Toyota Long Life Coolant.
 - Bleed the cooling system.
- Front Differential
 - Install a **NEW** drain plug washer and torque to spec.
 - **Torque Spec: 29 ft-lbs (39.2 N·m, 400 kgf·cm)**
 - Refill with Hypoid Gear Oil API GL-5 75W-90.
 - Install a **NEW** filler plug washer and torque to spec.
 - **Torque Spec: 29 ft-lbs (39.2 N·m, 400 kgf·cm)**

3. START THE VEHICLE AND INSPECT THE FOLLOWING FOR LEAKS

- Fuel System
 - Start the engine and let it run for 5 seconds, then stop the engine and inspect for leaks.
 - If there are no leaks, restart the engine and re-inspect.
- Cooling System
- Brake System
- Front Differential System

4. RECHARGE THE A/C SYSTEM AND CHECK FOR PROPER OPERATION AND REFRIGERANT LEAKS

5. CHECK THE OPERATION OF THE FOLLOWING SYSTEMS AND ADJUST AS NEEDED



Make sure to follow the procedure outlined in the appropriate repair manual for the vehicle you are working on when checking, and if needed, adjusting the operation of the systems listed below. This is an important step, and must be performed thoroughly to ensure proper operation of these systems.

- Parking Brake Travel
- Shift Control Lever

6. CHECK ALL FLUID LEVELS AND ADJUST AS NEEDED

NEW Replacement Parts

| Part Number | Part Name | Kit # | Qty |
|-------------|--------------------------------|-------|-----|
| 95381-04050 | Cotter Pin | 3 | 2 |
| 43514-34020 | Cap, Front Axle Hub Grease, RH | 3 | 1 |
| 43514-34020 | Cap, Front Axle Hub Grease, LH | 3 | 1 |

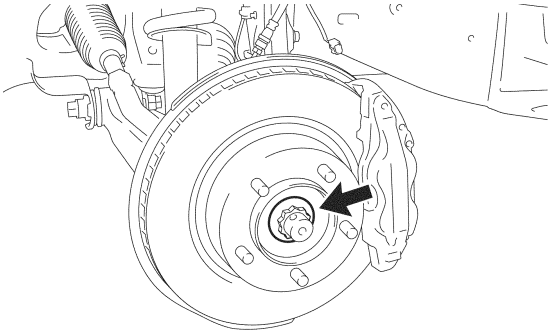

R1107260056

7. TORQUE THE FRONT AXLE NUT (4WD ONLY)

- a) Remove the front wheels.
- b) Torque the front axle nut to spec.

Torque Spec: 249 ft·lbs (338 N·m, 3447 kgf·cm)

- c) Reinstall the lock cap with the **NEW** cotter pin.
- d) Reinstall the **NEW** grease cap.
- e) Repeat the procedure on the opposite side.
- f) Reinstall the front wheels and torque to spec.

Torque Spec:

Aluminum Wheel - 97 ft·lbs (131 N·m, 1336 kgf·cm)

Steel Wheel - 154 ft·lbs (209 N·m, 2131 kgf·cm)

NOTE:

If the holes for the cotter pin are not aligned, tighten the axle nut further, up to 60 degree.

8. PERFORM A WHEEL ALIGNMENT

9. CHECK THE HEADLIGHT AIM AND ADJUST AS NEEDED

NEW Replacement Parts

| Part Number | Part Name | Kit # | Qty |
|-------------|-------------------|-------|-----|
| 90119-A0169 | Bolt (Large TYPE) | NA* | 5 |
| 90119-A0169 | Bolt (Small TYPE) | NA* | 2 |

* Individual Part(s)

10. REINSTALL THE ENGINE UNDER COVER No.1

- a) Reinstall the engine under cover No.1 with 5 **NEW** bolts and 3 screws, then torque to spec.
(Front Bumper Chrome Plated Type)
- b) Reinstall the engine under cover No.1 with 2 **NEW** bolts and 3 screws, then torque to spec.
(Front Bumper Resin Type)

Torque Spec: 21 ft·lbs (29 N·m, 296 kgf·cm)

11. CHECK FOR DTC'S AND REPAIR AS NEEDED

12. PERFORM INITIALIZATION

1. FINAL INSPECTION

- a) Check the operation of the following systems:

- 4WD System (**4WD Only**)
- Interior Lights
- Exterior Lights
- HVAC System
- Audio System
- Power Windows
- Power Door Locks
- All Gauges, Indicators and Warning Lights
- Cooling Fans
- Etc.

2. TEST DRIVE THE VEHICLE AND DOCUMENT FINAL REPAIR STATUS

- a) Test drive the vehicle and perform final repair sign off with the [Frame Replacement Inspection Sheet](#). This must be performed and signed off by an MDT, Shop Foreman or Service Manager and retained with Final R.O.

3. RECORD THE FRAME SERIAL NUMBER

a) Log into the frame tracker website using your dealer code and password.

URL: <https://zh-frame-tracker.imagespm.info/>

Default password: xxxxx

The screenshot shows the Toyota logo at the top center. Below it is a blue header bar with the text "ZH Frame Tracker: DEALER Site". Underneath is a "Login" section with the instruction "Complete all required (*) fields below." There are two input fields: "* User ID:" containing "82450" and "* Password:" with masked characters. A blue "Login" button is below the fields, and a link for "Forgot Password?" is at the bottom.

b) Select 2007 to 2008 Tundra ZH7 from the pick list.

The screenshot shows the "Prompt Vehicle Type" section. It includes the header "ZH Frame Tracker: DEALER Site" and "Toyota Administrator" with links for "Search Another Vin", "Print Screen", and "Log Out". The main heading is "Prompt Vehicle Type" with the instruction "Select the vehicle type that is having the frame replaced under the WEP." Below this is a "Vehicle Type" section with four radio button options: "2005 to 2010 Tacoma (ZH6)", "2007 to 2008 Tundra (ZH7) -- campaign will launch at a later date", "2005 to 2007 Sequoia (ZH8) -- campaign will launch at a later date", and "2008 Sequoia (ZH9) -- campaign will launch at a later date". A blue "Next:" button is at the bottom.

c) Enter the VIN of the vehicle.

The screenshot shows the "Prompt VIN" section. It includes the header "ZH Frame Tracker: DEALER Site" and "Toyota Administrator" with links for "Search Another Vin", "Print Screen", and "Log Out". The main heading is "Prompt VIN" with the instruction "Please scan, or type in, the VIN for this vehicle. If scanner doesn't populate the VIN field, place mouse cursor in that text box and try again." Below this is a "Vehicle Type (Campaign): 2005 to 2010 Tacoma (ZH6)" section. There is a "VIN:" label and an empty input field. A blue "Submit" button is below the field. To the right is an image showing a hand scanning a VIN label on a vehicle's frame with the text "Scan the VIN" overlaid in red.

d) Enter the frame serial off of the case label along with the R.O. number and Approved Frame Inspection Case Number.

Prompt for Repair Data for Vehicle in Campaign

This vehicle *is* part of the campaign. Enter the Case Label on the replacement frame into the field below. It is a unique serial number that must be matched to each VIN during repair.

For the 2005 to 2010 Tacoma, the case label can be located on the Driver's side outer frame rail behind the front cab mount.

| | | |
|---|---|--|
| Vehicle Type (Campaign): 2005 to 2010 Tacoma (ZH6) | Sample Case Label  |  |
| VIN: 5TEJU62NX9Z593626 | | |
| Case Label (8 characters eg AA111111): <input type="text"/> | | |
| R.O. Number: <input type="text"/> | | |
| TIS Frame Application Inspection Number (10 characters eg FI00000011): <input type="text"/> | |  |
| <input type="button" value="Submit"/> | | |

e) Press submit and print a copy of the serial number and file with the R.O.

1. APPENDIX

As required by Federal Regulations, please make sure all recalled parts (original parts) removed from the vehicle are disposed of in a manner in which they will not be reused. Adequate time has been provided in the repair time to cut up and dispose of the perforated frame.