

# CVT P2757 Valve Body Replacement

**Service Category** Drivetrain

**Section** CVT

**Market** USA

Toyota Supports  
 ASE Certification 

## Applicability

YEAR(S)	MODEL(S)	ADDITIONAL INFORMATION
2014 - 2017	Corolla	Transmission(s): CVT

## Introduction

Some 2014 – 2017 model year CVT Corolla vehicles may exhibit a MIL “ON” condition with Diagnostic Trouble Code (DTC) P2757 (Torque Converter Clutch Pressure Control Solenoid Performance [Shift Solenoid Valve SL]). Follow the Repair Procedure below to address this condition.

## Warranty Information

OP CODE	DESCRIPTION	TIME	QFP	T1	T2
TC1602	R & R Transmission Valve Body Assembly	3.1	35410-12871	8A	99

### APPLICABLE WARRANTY

- This repair is covered under the Toyota Powertrain Warranty. This warranty is in effect for 60 months or 60,000 miles, whichever occurs first, from the vehicle’s in-service date.
- Warranty application is limited to occurrence of the specified condition described in this bulletin.



## CVT P2757 Valve Body Replacement

### Required Tools & Equipment

REQUIRED EQUIPMENT	SUPPLIER	PART NUMBER	QTY
Techstream 2.0*	ADE	TS2UNIT	1
Techstream Lite		TSLITEPDLR01	
Techstream Lite (Green Cable)		TSLP2DLR01	

\* Essential SST.

#### NOTE

- Only ONE of the Techstream units listed above is required.
- Software version 11.20.019 or later is required.
- Additional Techstream units may be ordered by calling Approved Dealer Equipment (ADE) at 1-800-368-6787.

### Parts Information

PART NUMBER	PART NAME	QTY
35410-12871	Body Assy, Transmission Valve	1
35168-12091	Gasket, Transaxle Oil Pan	1
35145-07010	Gasket, Transaxle Case	1
90301-22019	Ring, O	1
90301-06004		1
08886-02505	ATF CVT FE (4 L can)	2*

\*Approximately 6 L of CVT fluid required for repair



## CVT P2757 Valve Body Replacement

### Repair Procedure

#### NOTICE

#### TO PREVENT CONTAMINATION - DO NOT CLEAN CVT CASE

- Perform work when it can be done without interruption.
- Prepare a clean work environment before initiating work.
- Be careful NOT to contaminate the CVT with debris and dust.
- Do NOT use a shop cloth, a paper shop cloth, or cotton gloves.
- Do NOT perform work in close proximity to others using air guns.

### Removing the Valve Body

#### NOTE

Do NOT open the package of the NEW Transmission Valve Body Assembly until just before replacement.

1. Remove the CVT fluid.

Refer to the Technical Information System (TIS), applicable model and model year Repair Manual:

- [2014](#) / [2015](#) / [2016](#) / [2017](#) Corolla:

*Drivetrain – CVT – “K313 CVT: Continuously Variable Transaxle Fluid: Replacement”*

2. Remove the drain plug and gasket from the transaxle oil pan sub-assembly.
3. Unscrew 16 bolts and remove the transaxle oil pan sub-assembly from the transmission case.
4. Remove the Transaxle Oil Pan Gasket from the transaxle oil pan sub-assembly.

Figure 1. Transaxle Oil Pan Bolts

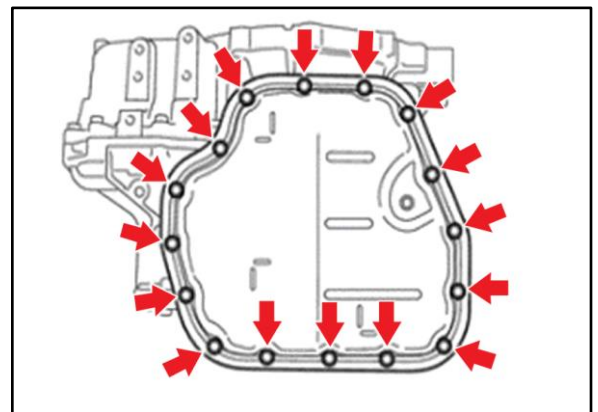

#### NOTE

Wash away ANY metal contaminants and sludge deposited inside the transaxle oil pan sub-assembly by using NEW CVT fluid and clean slightly as needed ensuring no contamination occurs. (Do NOT use brake cleaner. Metal contaminants attached to magnet are NOT required to be removed).



## CVT P2757 Valve Body Replacement

### Repair Procedure (Continued)

#### Removing Valve Body (Continued)

- Unscrew 3 bolts and remove the oil strainer from the Transmission Valve Body Assembly.

**Bolt A: (2) 16mm in length**

**Bolt B: (1) 25mm in length**

**Figure 2. Oil Strainer**

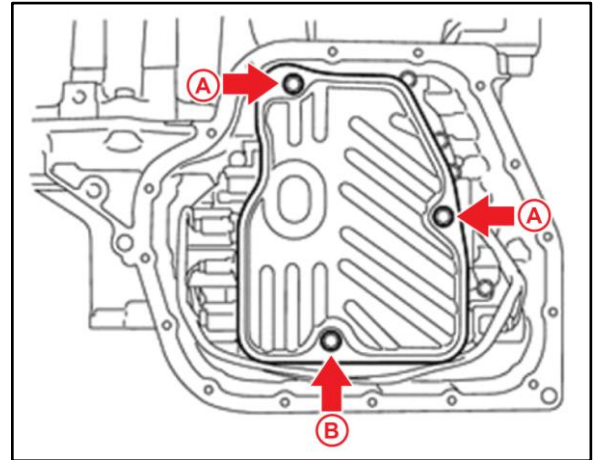

<b>A</b>	16 mm Bolt
<b>B</b>	25 mm Bolt

- Remove the O-ring from the oil strainer.

**NOTE**

Take care to ensure there is no contamination on the oil strainer.

**Figure 3. Oil Strainer O-ring**

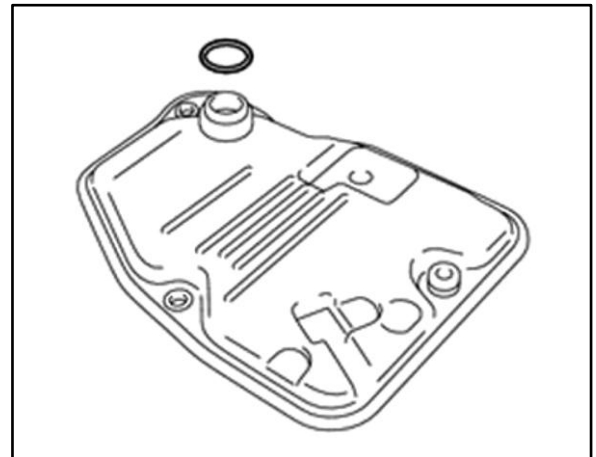



# CVT P2757 Valve Body Replacement

## Repair Procedure (Continued)

### Removing Valve Body (Continued)

7. Remove 1 bolt, oil temperature sensor clamp and disconnect 5 connectors of transmission harness from the Transmission Valve Body Assembly.

**NOTE**  
Do NOT remove respective solenoid valves from the transmission valve body.

**Figure 4. Transmission Valve Body Assembly**

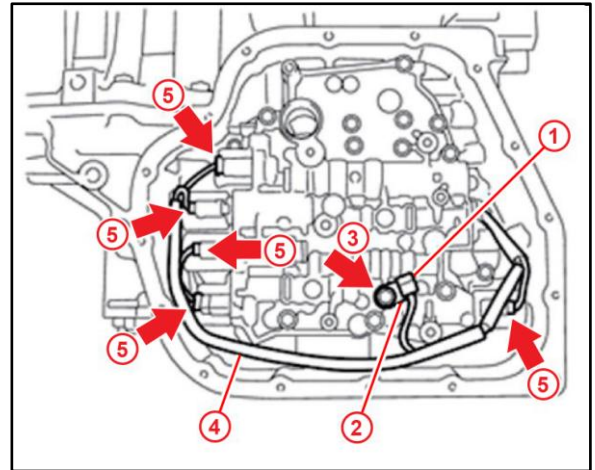

<b>1</b>	Oil Temperature Sensor
<b>2</b>	Oil Temperature Sensor Clamp
<b>3</b>	Oil Temperature Sensor Bolt
<b>4</b>	Transaxle Wire
<b>5</b>	Connectors

- A. To remove the connector, apply the needle-nose plier end to the male connector tab.

**Figure 5. Male Connector Tab**

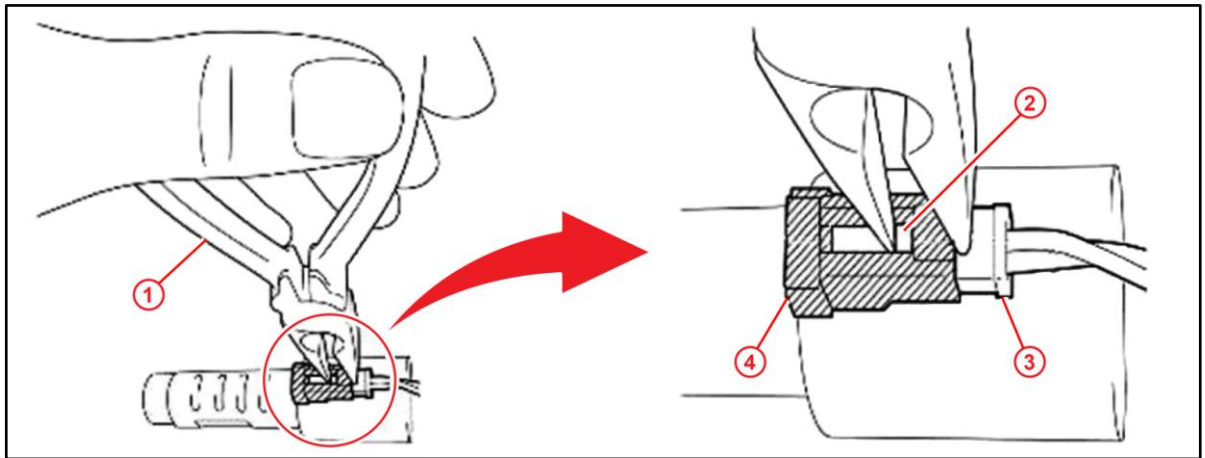

<b>1</b>	Needle Nose Pliers
<b>2</b>	Claw Portions

<b>3</b>	Male Connector
<b>4</b>	Female Connector



## CVT P2757 Valve Body Replacement

### Repair Procedure (Continued)

#### Removing Valve Body (Continued)

- B. Gently hold the needle-nose plier and then push the male connector tab underneath.

**Figure 6. Male Connector Cross Section**

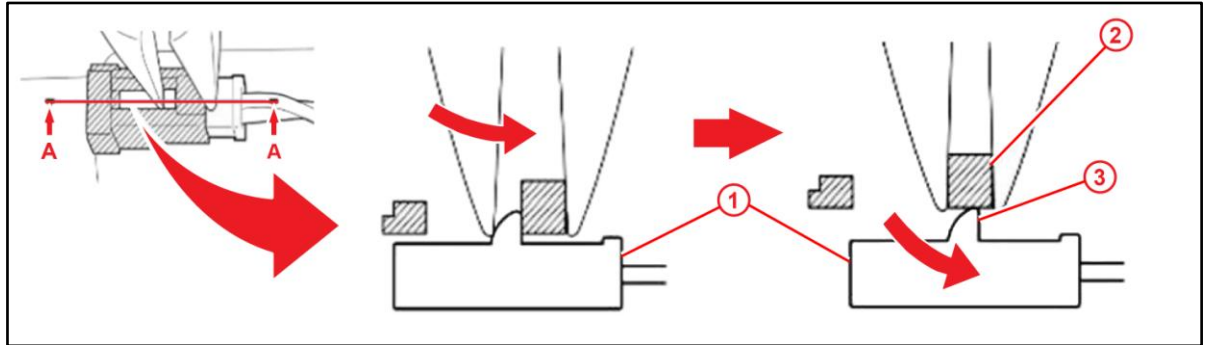

1	Male Connector
2	Female Connector Lock

3	Male Connector Claw
---	---------------------

- C. Pull out the male connector

**Figure 7. Male Connector**

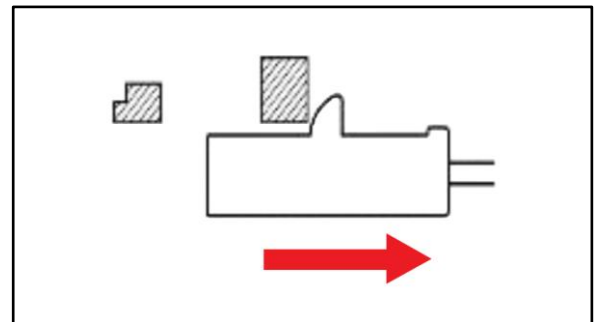

8. Remove the O-ring from the oil temperature sensor.



## CVT P2757 Valve Body Replacement

### Repair Procedure (Continued)

#### Removing Valve Body (Continued)

9. Unscrew the 13 bolts and remove the Transmission Valve Body Assembly from the transmission case.

**Bolt A: (2) 20mm in length**

**Bolt B: (7) 35mm in length**

**Bolt C: (4) 45mm in length**

**Figure 8. Transmission Valve Body**

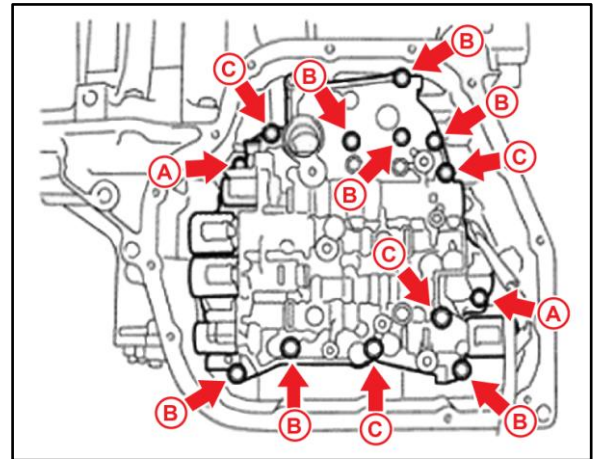

<b>A</b>	20 mm Bolt
<b>B</b>	35 mm Bolt
<b>C</b>	45 mm Bolt

10. Remove B1 gasket from the transmission case.

**NOTE**

As soon as removal of the transmission assembly is complete, install the Transmission Valve Body Assembly without ANY interruption to avoid contamination.

**Figure 9. B1 Gasket**

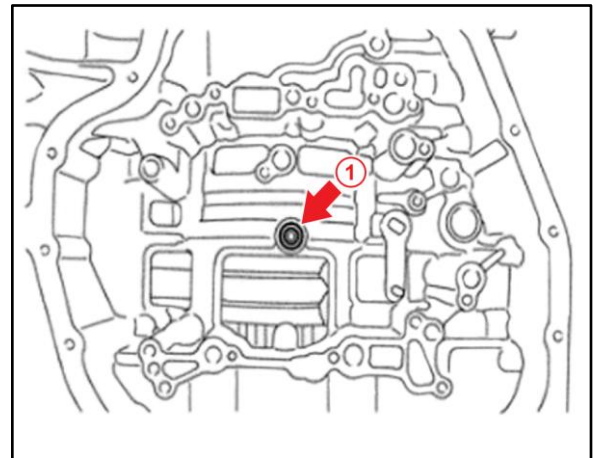

<b>1</b>	B1 Gasket
----------	-----------



## CVT P2757 Valve Body Replacement

### Repair Procedure (Continued)

#### Installing Valve Body

1. Apply a small amount of Toyota genuine MP grease No.2 or CVT fluid to the NEW B1 gasket.
2. Install the gasket to the transmission case.

#### NOTICE

To prevent B1 gasket from falling off, ensure that it is properly installed to the transmission case.

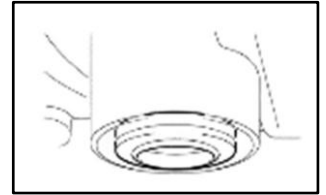

3. Install the Transmission Valve Body Assembly.

#### NOTICE

When installing the NEW Transmission Valve Body Assembly, fit it into the transmission case carefully as to NOT damage the top of the sub strainers that are positioned at the back of the Transmission Valve Body Assembly.

Figure 10. Front View

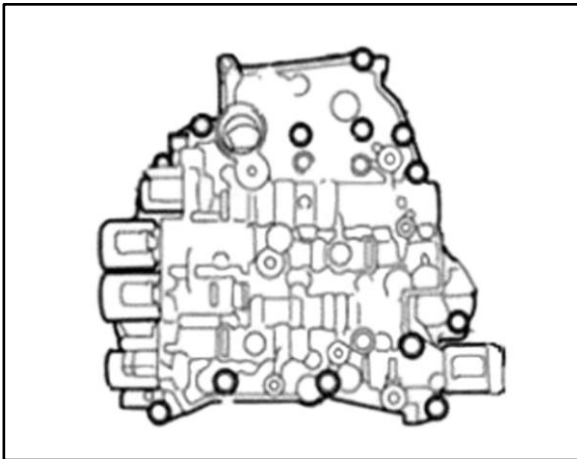
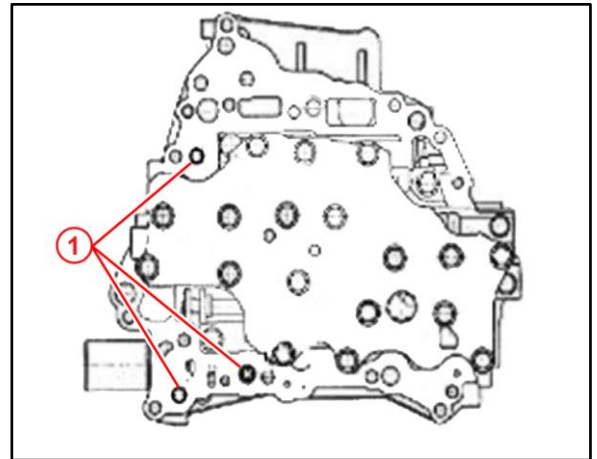

Figure 11. Back View



1 Sub Strainer

#### NOTICE

When installing the NEW Transmission Valve Body Assembly, hold the Transmission Valve Body Assembly horizontally to prevent the manual valve from falling off.





## CVT P2757 Valve Body Replacement

### Repair Procedure (Continued)

#### Installing Valve Body (Continued)

- A. Hold the Transmission Valve Body Assembly horizontally.
- B. Match the projection of the manual valve lever sub-assembly and the ditch of the manual valve as shown below.
- C. Install the NEW Transmission Valve Body Assembly to the transmission case horizontally.

**Figure 12.**

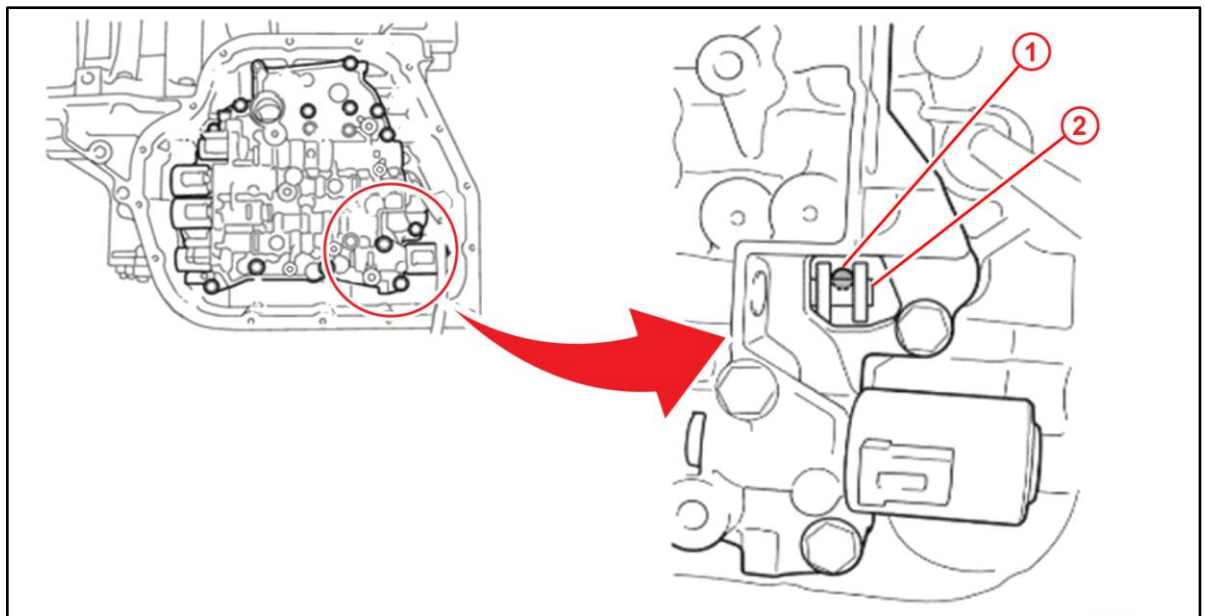

**1** Projection of Manual Lever Sub-Assembly

**2** Manual Valve

- D. Hold the 2 bolts (35 mm in length) by hand and install to position A.
- E. Temporarily tighten the bolts manually until they sit properly on the Transmission Valve Body Assembly.

**Figure 13. Transmission Valve Body**

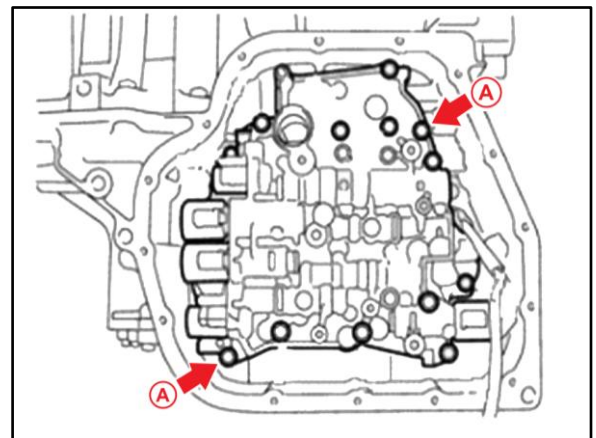

**A** 35 mm Bolt



# CVT P2757 Valve Body Replacement

## Repair Procedure (Continued)

### Installing Valve Body (Continued)

- F. Temporarily tighten the remaining 11 bolts manually until they sit properly.

**Bolt A: (2) 20mm in length**  
**Bolt B: (7) 35mm in length**  
**Bolt C: (4) 45mm in length**

- G. Tighten the 13 bolts.

**Torque: 10.8 N\*m (110 kgf\*cm)**

- H. Apply Toyota genuine CVT fluid to NEW O-ring and fit it to the oil temperature sensor.

- I. Fit 1 bolt, oil temperature sensor clamp and 5 connectors.

**Torque: 10.8 N\*m (110 kgf\*cm)**

**Figure 14. Transmission Valve Body**

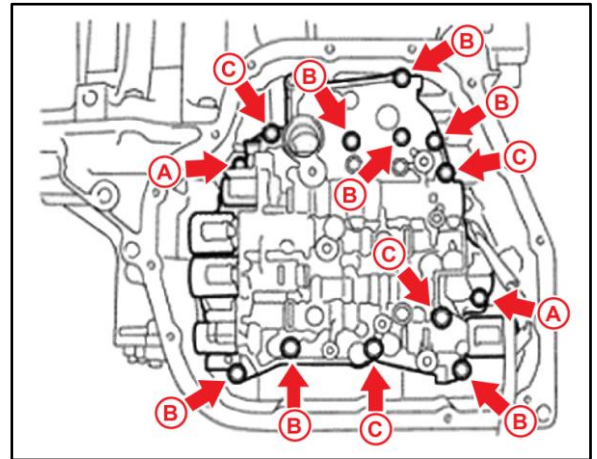

<b>A</b>	20 mm Bolt
<b>B</b>	35 mm Bolt
<b>C</b>	45 mm Bolt

- J. Install the transmission harness to the transmission valve.

**NOTE**  
 Refer to the table below for respective connectors, solenoid connectors and wiring of the transmission harness to ensure proper installation.

	1	2	3	4	5
<b>Solenoid Connector Color</b>	Black	Black	Blue	Black	Black
<b>Transaxle Harness Connector Color</b>	White	Green	Black	Green	White
<b>Wiring Color</b>	Purple	White/Black	Blue/Red	Light Blue	Yellow/Light Green



## CVT P2757 Valve Body Replacement

### Repair Procedure (Continued)

#### Installing Valve Body (Continued)

3. Install the oil strainer.
  - A. Apply Toyota genuine CVT fluid to the NEW O-ring and then fit it into the oil strainer.

**Figure 15. Oil Strainer O-ring**

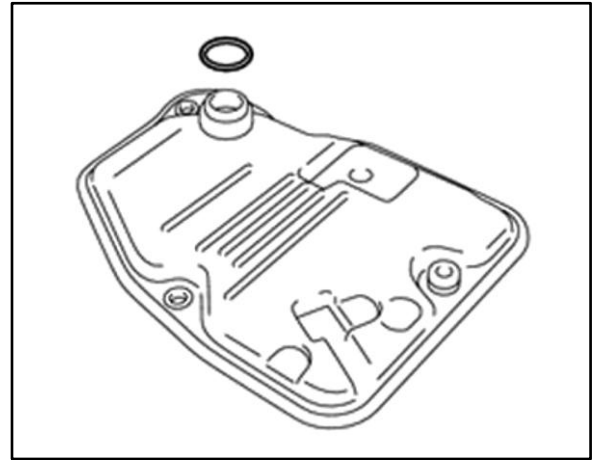

- B. Tighten the 3 bolts evenly, temporarily install the oil strainer to the Transmission Valve Body Assembly.

**Bolt A: (2) 16mm in length**

**Bolt B: (1) 25mm in length**

**Figure 16. Oil Strainer**

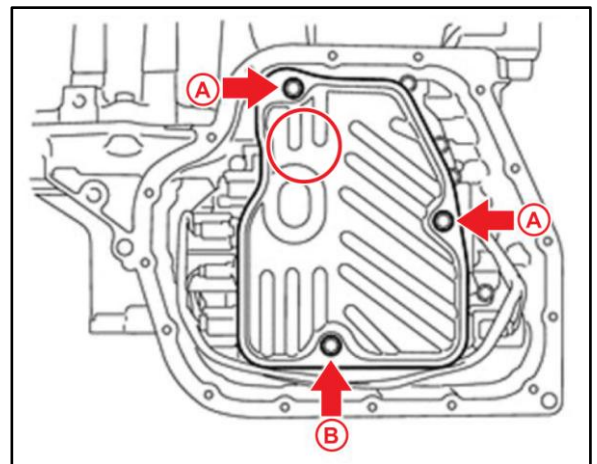

#### **NOTE**

When installing the oil strainer to the Transmission Valve Body Assembly, prevent the O-ring from being caught and apply pressure to the area below the A bolt at the 12 o'clock position as shown while keeping the strainer level.

Prevent the transmission wiring from being caught between the Transmission Valve Body Assembly and the oil strainer.

- C. Tighten the 3 bolts.

**Torque: 10.8 N\*m (110 kgf\*cm)**

	Apply Pressure Here
<b>A</b>	16 mm Bolt
<b>B</b>	25 mm Bolt



## CVT P2757 Valve Body Replacement

### Repair Procedure (Continued)

#### Installing Valve Body (Continued)

4. Install the transaxle oil pan sub-assembly.
  - A. Install the NEW gasket.

**NOTE**

Clean the mating surfaces of the transaxle oil pan sub-assembly and the transmission case with wipes to remove grease, moisture and/or dirt (Do NOT use brake cleaner).

- B. Tighten the 16 bolts evenly, and temporarily install the transaxle oil pan sub-assembly to the transmission case.

**NOTE**

Prevent the transmission wiring from being caught between the transmission case and transaxle oil pan sub-assembly by pushing wiring to the center of transaxle.

**Figure 17. Transaxle Oil Pan Bolts**

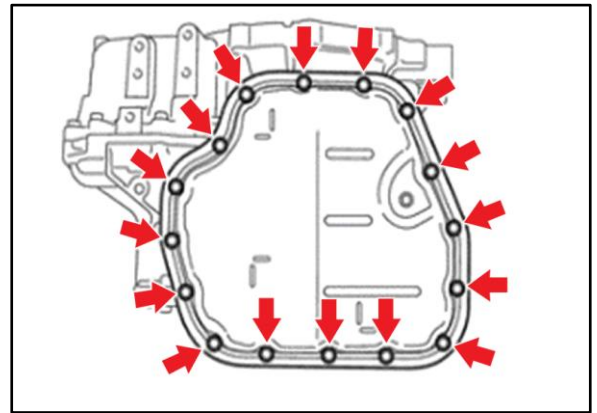

- C. Tighten the 16 bolts.
 

**Torque: 7.8 N\*m (80 kgf\*cm)**
    - D. Mount to overflow tube.
 

**Torque: 1.7 N\*m (17 kgf\*cm)**
    - E. Tighten the overflow plug with the gasket installed.
 

**Torque: 40 N\*m (408 kgf\*cm)**
5. Refill the CVT fluid.
 

Refer to TIS, applicable model and model year Repair Manual:

  - [2014](#) / [2015](#) / [2016](#) / [2017](#) Corolla:
 

*Drivetrain – CVT – “K313 CVT: Continuously Variable Transaxle Fluid: Replacement”*
6. Clear the Diagnostic Trouble Codes.
7. Using TIS Techstream perform a Health Check and confirm no current DTCs are present.

**NOTE**

If current DTCs are present, diagnose per Repair Manual procedures.

8. Test drive the vehicle to confirm proper vehicle operation.