

**** TECHNICAL INFORMATION NOTICE ****

DATE: March 9, 2018
TO: Mitsubishi Motors US & Puerto Rico Dealer Service and Parts Managers
RE: Driver's Power Seat Adjuster Assembly
TIN NO. TIN-18-52A-001

.....

AFFECTED VEHICLES: 2016 and newer Outlander produced after 3/1/2016 (2.4L) and 3/3/2016 (3.0L)

PURPOSE

On May 2, 2017, TSB-17-52A-003 (Slight Intermittent Movement in Driver's Power Seat) was published to address customer concerns of a slight movement of the driver's power seat. The TSB instructed dealers to replace affected seat adjuster assemblies with an improved countermeasure part, part number 6922A119 (see illustration).

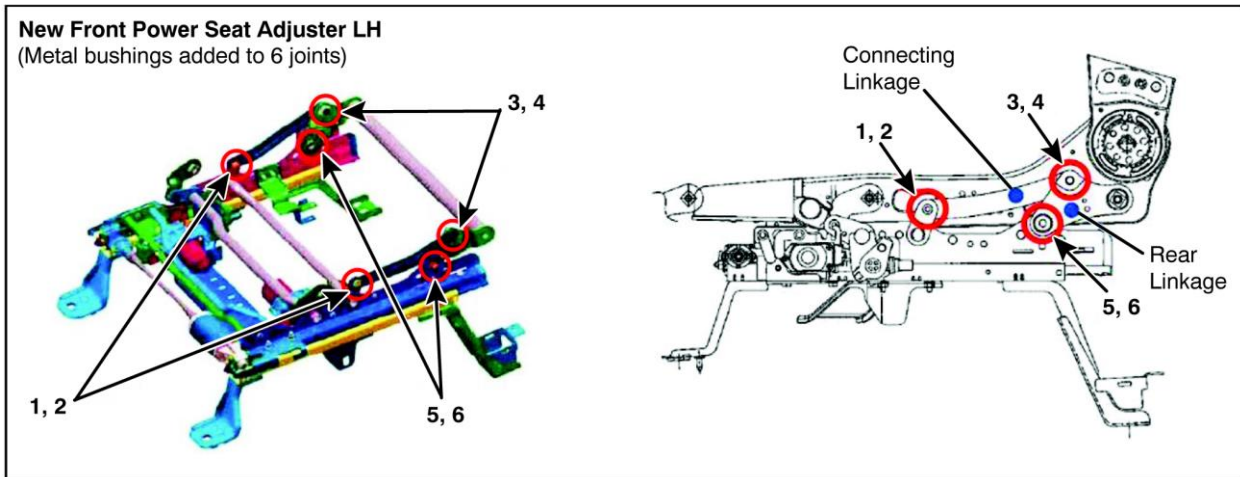

This concern affected Outlander vehicles built before production dates of 3/1/2016 (2.4L) and 3/3/2016 (3.0L). For vehicles built **AFTER** these production dates, it is **not recommended** to replace the driver's seat adjuster since those vehicles already have the countermeasure parts in place. However, on a case-by-case basis, contact your DPSM to review the situation further. **A DPSM PWA is required for replacement of the driver seat adjuster on affected vehicles.**