

Instrument Cluster, Reprogramming VN, VHD, VAH, VT

EC 1801, Instrument Cluster, Reprogramming (MID 140)

(March 2018)

On Certain Volvo Trucks with the Volvo engine the cluster may not fault the ambient temperature sensor for electrical failures, this may cause engine to default to a fixed ambient temperature value. This is due to a software issue in the instrument cluster. To correct this issue follow the procedure below:

Decommissioning the Truck for Repair

You must read and understand the precautions and guidelines in Service Information, group 30, "General Safety Practices, Electrical" before performing this procedure. If you are not properly trained and certified in this procedure, ask your supervisor for training before you perform it.

NOTE: Information is subject to change without notice. Illustrations are used for reference only and can differ slightly from the actual vehicle being serviced. However, key components addressed in this information are represented as accurately as possible.

- 1 Park the vehicle on a flat and level surface.
- 2 Apply the parking brake.
- 3 Place the transmission in neutral or park.
- 4 Install the wheel chocks.

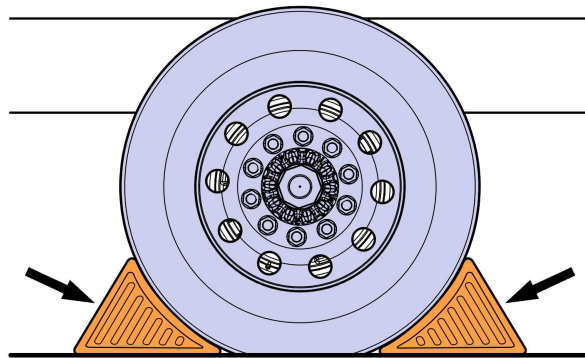

W7086748

Instrument Cluster, Reprogramming Procedure

- 1 Connect Premium Tech Tool to the vehicle.
- 2 Reprogram the instrument cluster (MID 140).

Commissioning the Truck for Operation

- 1 Remove the wheel chocks.

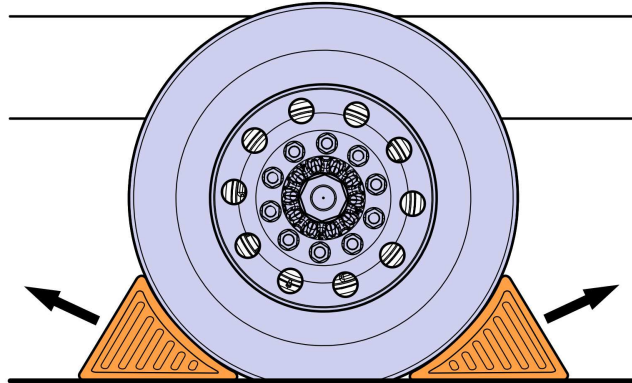

W7086759

Reimbursement

This repair is covered by an authorized Service Program. Reimbursement is obtained via the normal claim handling process.	UCHP Reimbursement
Claim Type (used only when uploading from the Dealer Bus. Sys.)	B
Recall Status	
Vehicle inspected, repair not required	
Vehicle repaired per instruction	
Labor Code	
Primary Labor Code (Instrument Cluster, Reprogramming)	3811-22-02-01 0.3 hrs
Take to take charge and determine campaign status	1700-16-01-01 0.3 hrs
Causal Part	3092072
SCC Code	M0003
Authorization Number	NA
Expiration Date	NA

Note: Take Charge Time is not included in the Labor Code for this operation. Take charge may be eligible but can only be used once per repair visit. If vehicle is having other warranty repairs performed, take charge should be charged to the warranty repair, otherwise take charge can be charged to this service program.