

Steering Column "Pop" Noise

Service Category Steering

Section Steering Column

Market USA

Toyota Supports
 ASE Certification 

Applicability

YEAR(S)	MODEL(S)	ADDITIONAL INFORMATION
2009 – 2013	Venza	

Introduction

Some 2009 – 2013 model year Venza vehicles may exhibit a “pop” noise from the steering column when turning the steering wheel sharply during low speed maneuvers. Perform the repair procedure outlined in this bulletin to address this condition.

Parts Information

PREVIOUS PART NUMBER	CURRENT PART NUMBER	PART NAME	QTY
N/A	04007-76133	Grease Kit w/2 Cylinders	0.5 – 0.6 ml per vehicle

Warranty Information

OP CODE	DESCRIPTION	TIME	OFP	T1	T2
ST1300	Tilt Lever Grease Application	0.5	45250-0T010 45250-0T052 45250-0T062	91	55

APPLICABLE WARRANTY

- This repair is covered under the Toyota Basic Warranty. This warranty is in effect for 36 months or 36,000 miles, whichever occurs first, from the vehicle's in-service date.
- Warranty application is limited to occurrence of the specified condition described in this bulletin.

Steering Column "Pop" Noise

Repair Procedure

1. Confirm condition.

With the vehicle in Park and engine running, release the column tilt/telescopic lever and rotate the steering wheel from right lock to left lock several times (refer to Figure 1).

With the tilt/telescopic lever released, did the steering "pop" noise go away?

- **YES** — This bulletin DOES apply. Go to step 2.
- **NO** — This bulletin does NOT apply. Refer to the applicable Repair Manual for diagnosis.

Figure 1.

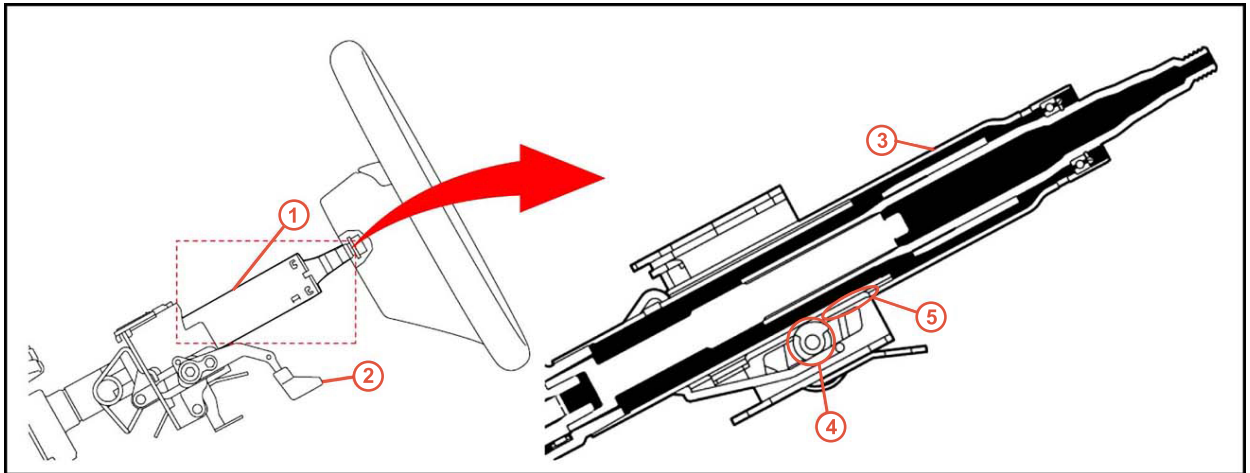

1	Steering Column Assembly
2	Column Tilt/Telescopic Lever
3	Steering Column Tube

4	Stopper Pin "Cam"
5	Steering Column Inner Jacket

Steering Column "Pop" Noise

Repair Procedure (Continued)

2. Remove the lower steering column cover.
 - A. Remove the 2 screws.
 - B. Push the right and left sides of the lower steering column cover, and disengage the 2 claws.

Figure 2.

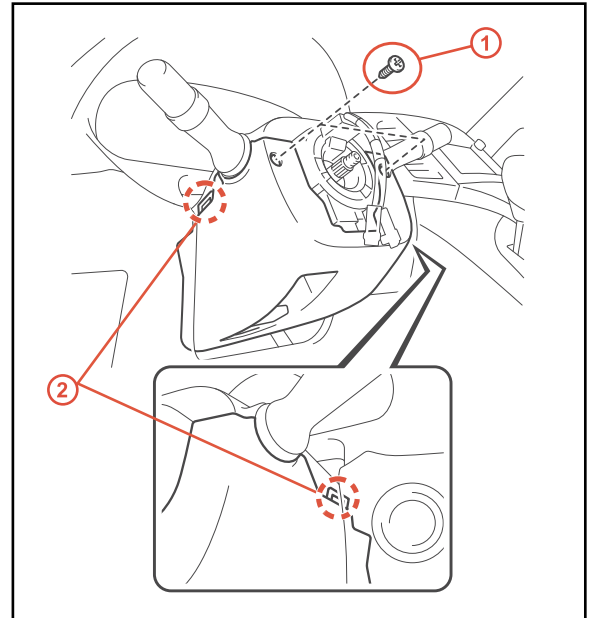

1	Screws
2	Claws

3. With the column tilt/telescopic lever released, fully extend the column telescope towards the driver's seat and tilt column up to the highest tilt position.
4. Using the syringe from the grease kit, apply grease to the column inner jacket and the stopper pin "cam".

Grease Amount:
Column Inner Jacket: 0.3 – 0.4 ml
Stopper Pin Cam: 0.2 ml

Figure 3.

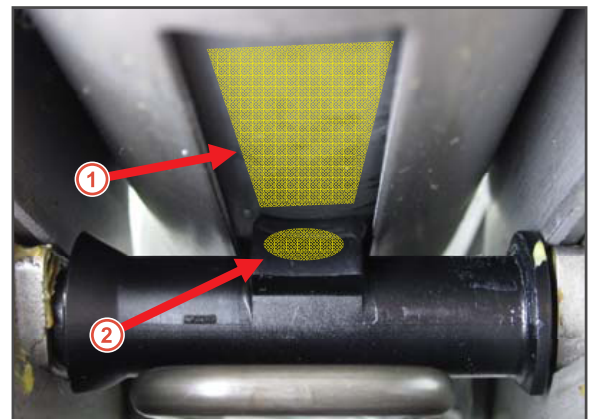

1	Apply Grease to Column Inner Jacket
2	Apply Grease to Stopper Pin "Cam"

Steering Column "Pop" Noise

Repair Procedure (Continued)

5. Cycle the steering column telescope (extend and retract) 10 times to distribute grease evenly.
6. Engage the column tilt/telescopic lever.
7. With the vehicle in Park and engine running, confirm that NO noise is present by cycling the steering wheel from right lock to left lock several times.
 - A. If noise still occurs, inspect for distribution of grease over areas shown in Figure 3 and apply additional grease as necessary.

- B. If noise is no longer present, reinstall the lower column cover. **Figure 4.**

- (1) Engage the 2 claws to install the lower steering column cover.
- (2) Install the 2 screws.

Torque: 2.0 N*m (20 kgf*cm, 18 in*lbf)

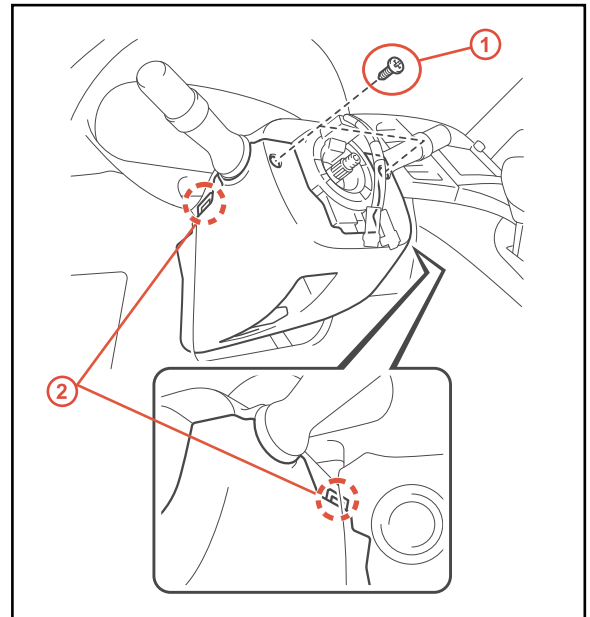

1	Screws
2	Claws