

Front Side Window Glass Rattle Noise

Service Category Vehicle Exterior

Section Window/Glass

Market USA

Toyota Supports
 ASE Certification 

Applicability

YEAR(S)	MODEL(S)	ADDITIONAL INFORMATION
2009 – 2013	Corolla	
2009 – 2012	Matrix	

Introduction

Some 2009 – 2013 model year Corolla and 2009 – 2012 model year Matrix vehicles may exhibit a rattle, pop, or click noise when operating the driver or passenger front window glass. In some cases, the front window may become inoperative. This may be due to loose window regulator mounting bolts. Use the following repair procedure to address this condition.

Production Change Information

This bulletin applies to vehicles produced **BEFORE** the Production Change Effective VINs shown below.

MODEL	DRIVETRAIN	PRODUCTION CHANGE EFFECTIVE VIN
Corolla	TMMMS	5YFBU4EE#DP076063
	TMMC	2T1BU4EE#CC846075
Matrix	TMMC	2T1##4EE#CC846033

Parts Information

PREVIOUS PART NUMBER	CURRENT PART NUMBER	PART NAME	QTY
90119-A0125	Same	Bolt, W/ Washer	As Needed

Required Tools & Equipment

SPECIAL SERVICE TOOLS (SST)	PART NUMBER	QTY
Plastic Pry Tool Set*	00002-06000-01	1

* Essential SST.

Front Side Window Glass Rattle Noise

Required Tools & Equipment (Continued)

NOTE

Additional SSTs may be ordered by calling 1-800-933-8335.

REQUIRED MATERIAL	QUANTITY
Loctite® Threadlocker Blue 242® (or equivalent)	As Needed
Butyl Tape – 3M® Ribbon Seal (or equivalent)	As Needed

Warranty Information

OP CODE	DESCRIPTION	TIME	OFF	T1	T2
BD1246	R & R Regulator Bolts	0.4	90119-A0125	62	14
Combo A	Other side (if needed)	0.4			

APPLICABLE WARRANTY

- This repair is covered under the Toyota Basic Warranty. This warranty is in effect for 36 months or 36,000 miles, whichever occurs first, from the vehicle's in-service date.
- Warranty application is limited to occurrence of the specified condition described in this bulletin.

Overview

NOTE

There are 2 separate Repair Procedures for Corolla and Matrix vehicles.

Front Side Window Glass Rattle Noise

Corolla Repair Procedure

1. Verify the condition.
2. Remove front door window regulator handle assembly (without power window).
 - A. Using a clip remover, remove the snap ring.
 - B. Remove the front door window regulator handle assembly and front door regulator inside handle plate.
3. Remove the front door inside handle bezel using the molding remover and disengaging the 3 claws.

Figure 1.

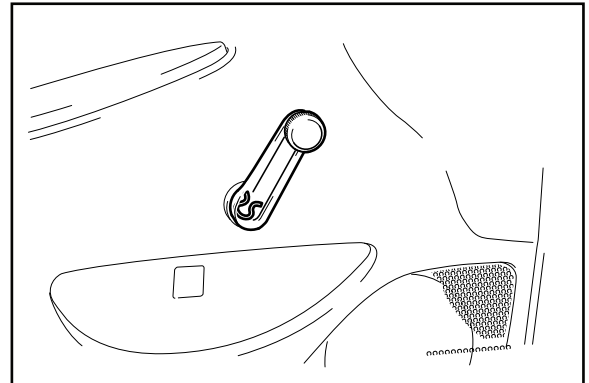
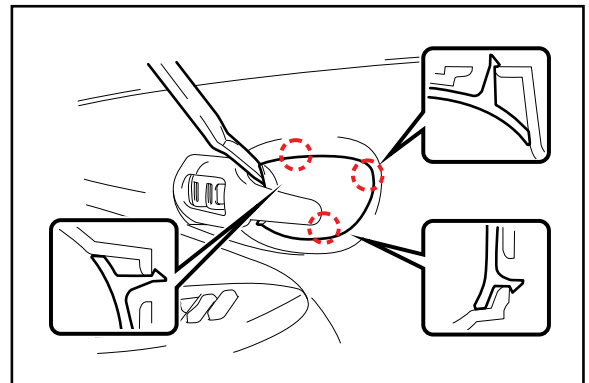

Figure 2.



Front Side Window Glass Rattle Noise

Corolla Repair Procedure (Continued)

4. Remove the front armrest upper base panel (without power window).
 - A. Using a molding remover, disengage the 2 clips and 6 claws, and remove the front armrest upper base panel.
 - B. With power door lock: Disconnect the connector.

Figure 3.

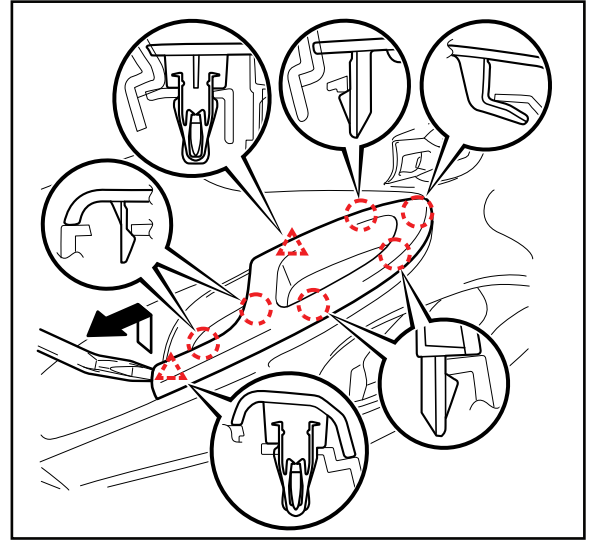

5. Remove the front armrest upper base panel (with power window).
 - A. Using a molding remover, disengage the 2 clips and 6 claws.
 - B. Disconnect the connector and remove the front armrest upper base panel.

Figure 4.

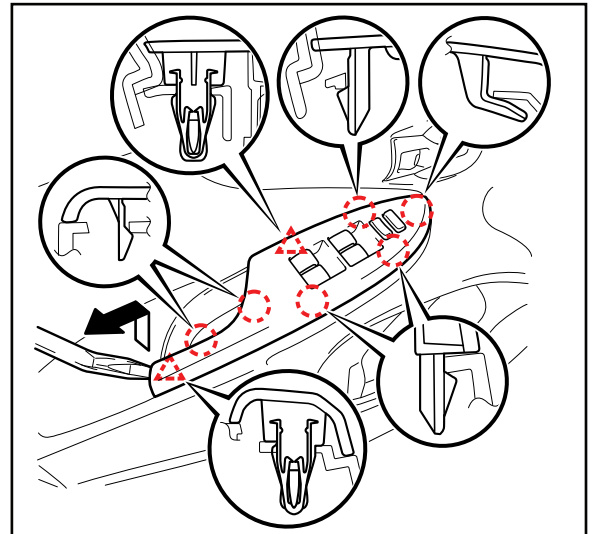

6. Remove the front door trim board sub-assembly.

Front Side Window Glass Rattle Noise

Corolla Repair Procedure (Continued)

- A. Using a molding remover, disengage the claw and disconnect the door armrest cap.

Figure 5.

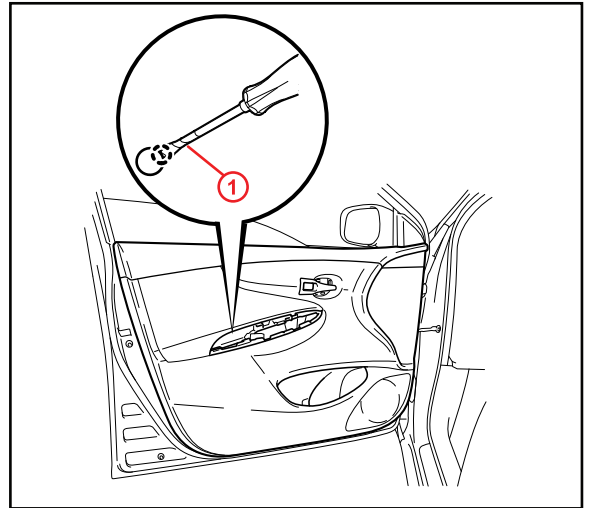

1	Molding remover
----------	------------------------

- B. Remove the 2 screws.

Figure 6.

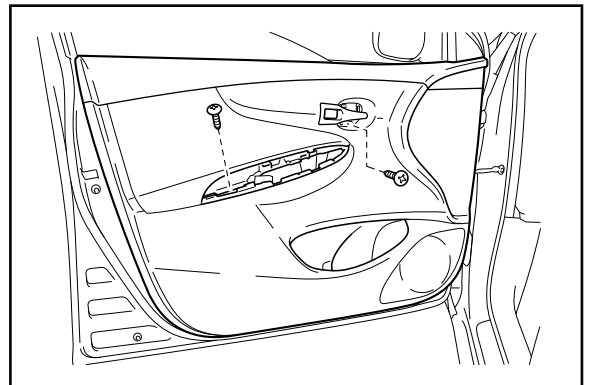

Front Side Window Glass Rattle Noise

Corolla Repair Procedure (Continued)

- C. Using a clip remover, disengage the 10 clips.

Figure 7.

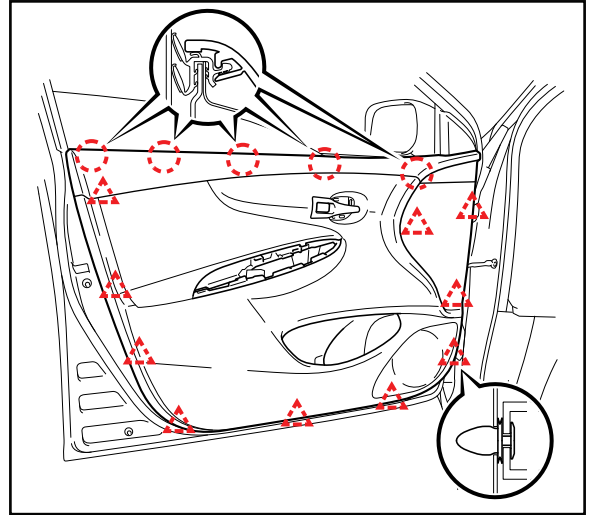

- D. Disengage the 5 claws and separate the front door trim board sub-assembly from the front door inner glass weatherstrip.
- E. Disengage the 2 claws and disconnect the front door inside handle sub-assembly.

Figure 8.

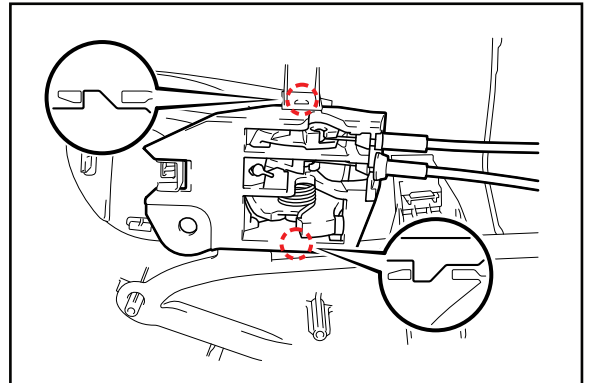

Front Side Window Glass Rattle Noise

Corolla Repair Procedure (Continued)

7. Remove the front door service hole cover.

Figure 9.

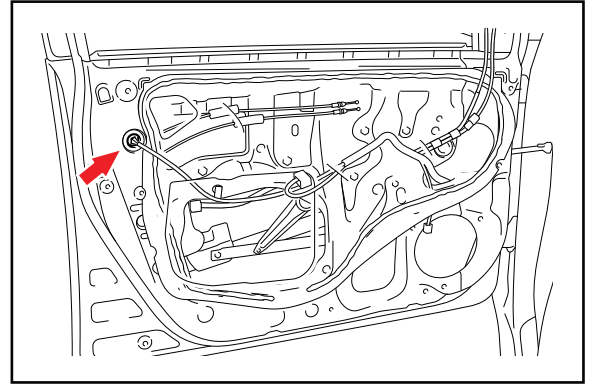

- A. With power door lock:

- (1) Disconnect the connector.
- (2) Remove the front door service hole cover.

Figure 10.

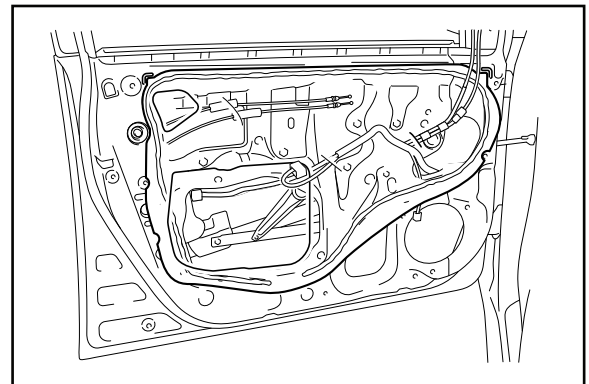

NOTE

Remove any remaining butyl tape from the door.

8. Remove the 2 bolts holding the window to the regulator assembly.

NOTE

One or both of these bolts may be loose and/or found in the bottom of the door.

Figure 11.

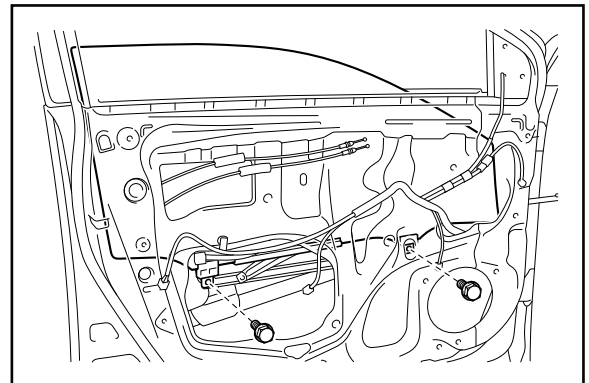

Front Side Window Glass Rattle Noise

Corolla Repair Procedure (Continued)

9. Reinstall the window regulator bolts using Loctite® Threadlocker Blue 242® (or equivalent).
Torque: 8.0 N*m (82 kgf*cm, 71 in*lbf)
10. Temporarily install the power window switch or window handle to operate the window assembly and verify proper window operation.
11. Reassemble the door in reverse order.

Matrix Repair Procedure

1. Verify the condition.
2. Remove the front door window regulator handle assembly (without power window).
 - A. Using a clip remover, remove the snap ring.
 - B. Remove the front door window regulator handle assembly and front door regulator inside handle plate.
3. Remove the front door inside handle bezel by using a molding remover and disengaging the 3 claws.

Figure 12.

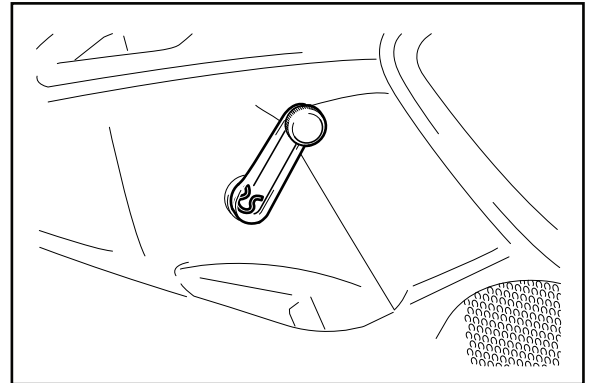
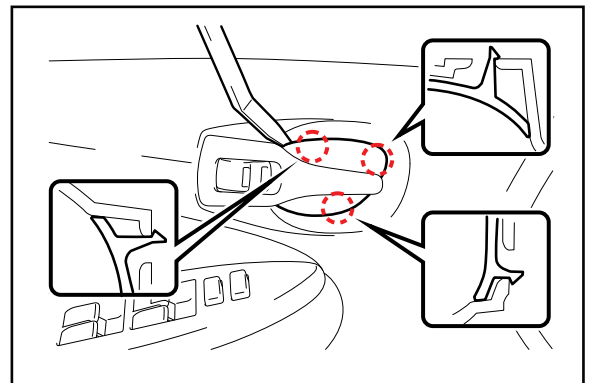

Figure 13.



Front Side Window Glass Rattle Noise

Matrix Repair Procedure (Continued)

4. Remove the front armrest upper base panel (without power window).
 - A. Using a molding remover, disengage the clip.
 - B. Using the molding remover, disengage the 7 claws and remove the front armrest upper base panel.

Figure 14.

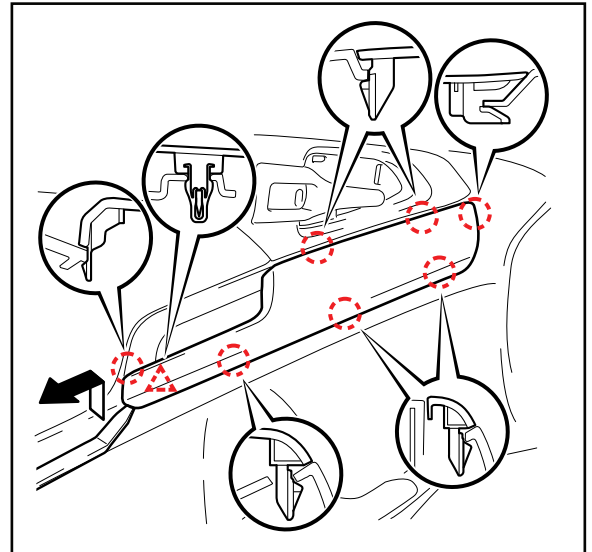

5. Remove the front armrest upper base panel (with power window).
 - A. Using the molding remover, disengage the clip and 7 claws.
 - B. Disconnect the connector and remove the front armrest upper base panel.

Figure 15.

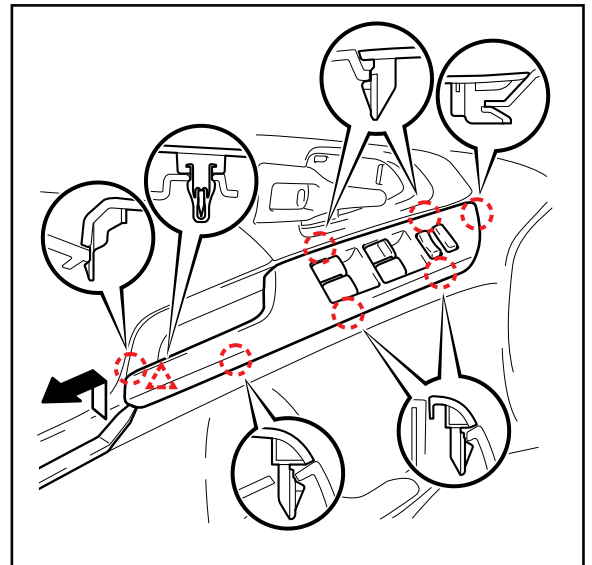

6. Remove the front door trim board sub-assembly.

Front Side Window Glass Rattle Noise

Matrix Repair Procedure (Continued)

A. Remove the 3 screws.

Figure 16.

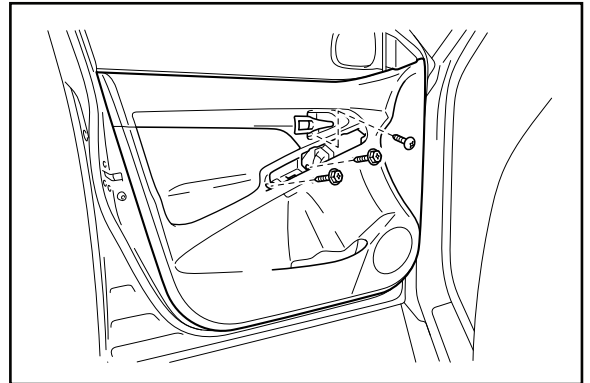

B. Using a clip remover, disengage the 10 clips.

Figure 17.

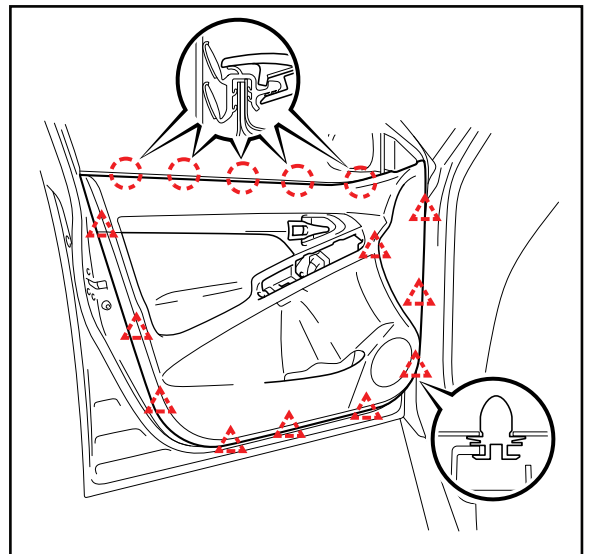

C. Disengage the 5 claws and separate the front door trim board sub-assembly from the front door inner glass weatherstrip.

Front Side Window Glass Rattle Noise

Matrix Repair Procedure (Continued)

- D. Disengage the 2 claws and disconnect the front door inside handle sub-assembly.

Figure 18.

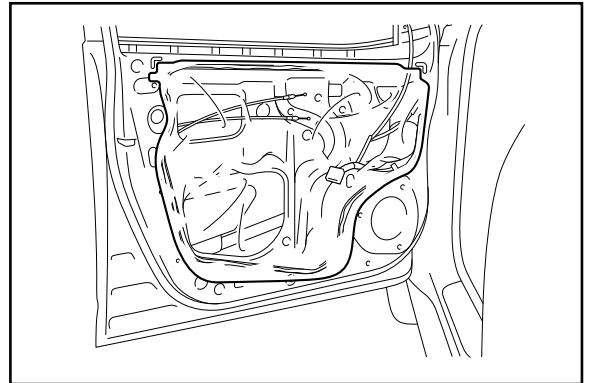

- 7. Remove the front door service hole cover (without power door lock).

Figure 19.

NOTE

Remove any remaining butyl tape from the door.

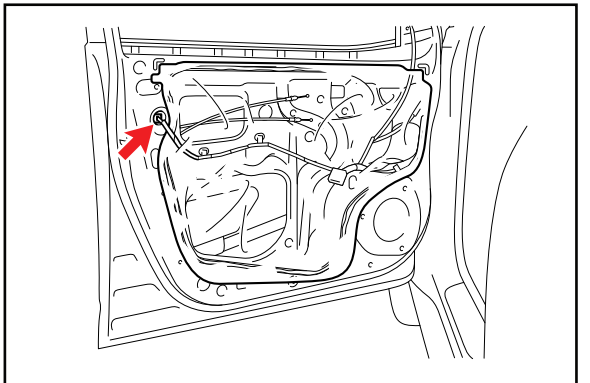

- 8. Remove the front door service hole cover (with power door lock).

Figure 20.

- A. Disconnect the connector.
- B. Remove the front door service hole cover.

NOTE

Remove any remaining butyl tape from the door.

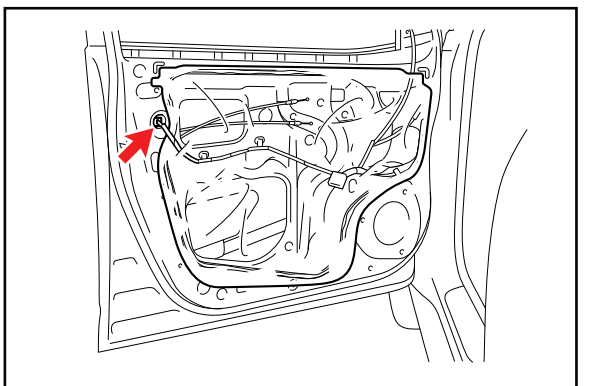

Front Side Window Glass Rattle Noise

Matrix Repair Procedure (Continued)

9. Remove the 2 bolts holding the window to the regulator assembly.

NOTE

One or both of these bolts may be loose and/or found in the bottom of the door.

Figure 21.

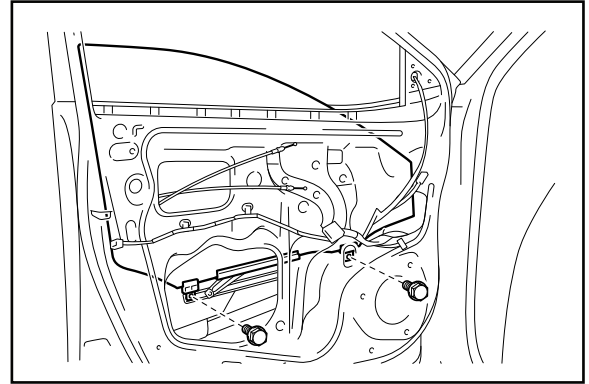

10. Reinstall the window regulator bolts using Loctite® Threadlocker Blue 242® (or equivalent).
Torque: 8.0 N*m (82 kgf*cm, 71 in*lbf)
11. Temporarily install the power window switch or window handle to operate the window assembly and verify proper window operation.
12. Reassemble the door in reverse order.