

Integration Relay Poor Ground

Service Category Power Source/Network

Section Power Distribution

Market USA

Lexus Supports
ASE Certification 

Applicability

YEAR(S)	MODEL(S)	ADDITIONAL INFORMATION
2013	ES300H	
2013	ES350	

Introduction

Some 2013 model year ES 350 and ES 300h vehicles may exhibit a condition where the passenger headlight and rear defogger operate continuously.

This condition may be caused by a poor ground for the Engine Room Junction Block Assembly on the left fender side panel bracket after a collision repair. This may occur during body shop repairs or other repairs where the left side fender bracket grounds were left loose, not properly attached using correct bolts, or improperly painted, and the vehicle's battery was connected.

NOTICE

BEFORE performing work on electronic components, components including grounds, or fender brackets with grounds, disconnect the cable from the negative (-) battery terminal to prevent damage to the electrical system or components.

Parts Information

PREVIOUS PART NUMBER	CURRENT PART NUMBER	PART NAME	QTY
53804-33040	Same	Bracket, Front Side Panel, LH	1
82720-33350	Same	Block Assy, Engine Room Junction	1
82720-33380	Same		1
82720-33390	Same		1

Warranty Information

OP CODE	DESCRIPTION	TIME	OFF	T1	T2
N/A	Not Applicable to Warranty	-	-	-	-

Integration Relay Poor Ground

Required Tools & Equipment

SPECIAL SERVICE TOOLS (SST)	PART NUMBER	QTY
GR8 Battery Diagnostic Station*	00002-MCGR8	1

NOTE
Additional SSTs may be ordered by calling 1-800-933-8335.

* Essential SST.

Repair Procedure

CAUTION
At NO time should the battery be connected when any ground attachments (A1, A2, apron bolts, or front side panel bracket) are loose.

1. Has the vehicle had body work or the A1/A2 grounds, or apron mounting bolts disconnected?
 - **YES / UNSURE** — Continue to step 2.
 - **NO** — This bulletin does NOT apply. Continue diagnosis using the applicable Repair Manual.

Figure 1.

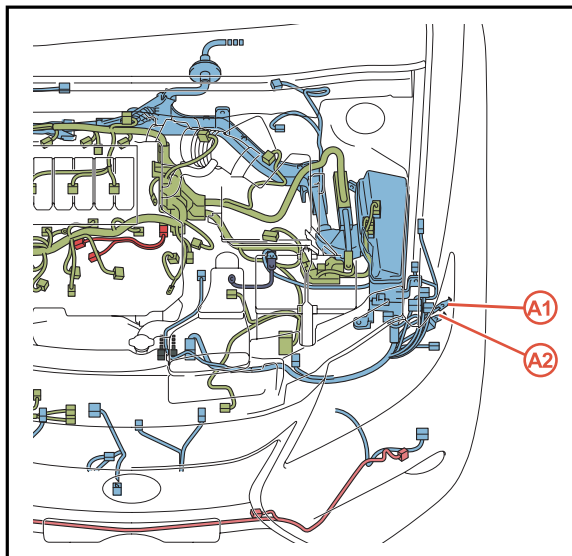

A1	A1 Ground
A2	A2 Ground

Figure 2.

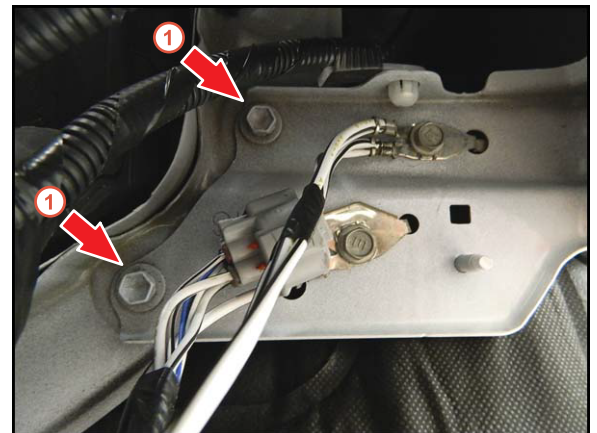

1	Apron Bolts
----------	-------------

Integration Relay Poor Ground

Repair Procedure (Continued)

2. Disconnect the negative (-) battery terminal.
3. Charge the battery with the GR8 Battery Diagnostic Station until charge is over 12 volts.
4. Remove the front bumper cover and left headlight assembly.

Refer to the Technical Information System (TIS), applicable model and model year Repair Manual:

- Bumper Cover:

2013 [ES 350](#) / [ES 300h](#):

Vehicle Exterior – Exterior Panels/Trim – “Exterior Panels/Trim: Front Bumper: Removal”

- Left Headlight Assembly:

2013 [ES 350](#) / [ES 300h](#):

Vehicle Exterior – Lighting (ext) – “Lighting (Ext): Headlight Assembly: Removal”

5. Visually inspect the wiring harness at the Engine Room Junction Block Assembly for physical damage.

Is there physical damage to the wiring harness?

- **YES** — Replace the affected harness(es). Once replaced, continue to step 6.
- **NO** — Continue to step 6.

6. Reconnect the battery and verify passenger headlight is ON and rear defogger is warm.

- **If YES** — Continue to step 7.
- **If NO** — This bulletin does NOT apply. Continue diagnosis using the applicable Repair Manual.

NOTICE

- **When the rear defogger grid is warm to the touch and the right side headlamp is ON when the key is OFF, or the cooling fans are running continuously, please remove the negative (-) battery terminal to prevent additional damage as soon as testing is complete.**
- **Vehicles exhibiting these conditions should not be left unattended before or after testing unless the negative (-) battery terminal is disconnected.**

Integration Relay Poor Ground

Repair Procedure (Continued)

7. Perform voltage drop test* from the two left fender bracket ground wire eyelet tabs to body ground (see Figure 3).

* For detailed information on performing the voltage drop test, please refer to the Quick Training Guide "[QL611A: Body Electrical Diagnosis](#)" found on the Technical Information System (TIS), under *Technical Training – QTG – Skill Area: Electrical & A/C*.

CAUTION

At NO time should the battery be connected when any ground attachments (A1, A2, or apron mounting bolts) are loose.

- A. Use a left front strut tower mounting bolt as a good body ground (see Figure 4).
- B. To perform voltage drop test, connect the negative lead of the DVOM to the strut tower bolt, and the positive lead to the ground wire eyelet tab.

Figure 3.

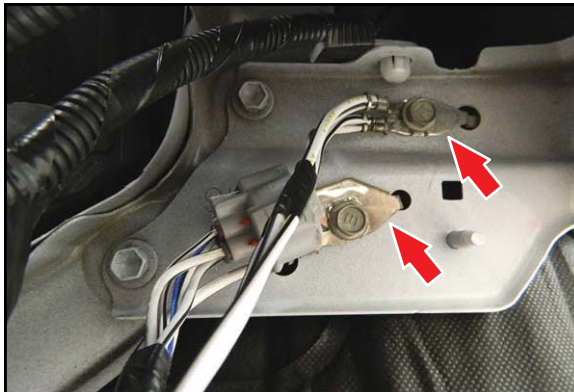
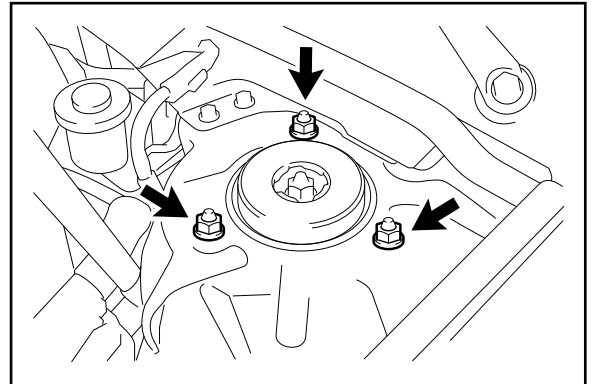

Figure 4.



8. Is voltage drop from each ground location less than 0.2 volts?
 - **YES** — This bulletin does NOT apply. Continue diagnosis using the applicable Repair Manual.
 - **NO** — A voltage drop of 0.2 volts or more from either of the ground locations may indicate poor continuity in the ground circuit. Proceed to step 9.
9. With battery disconnected, remove the left hand fender bracket from the apron for inspection.

Integration Relay Poor Ground

Repair Procedure (Continued)

10. Inspect the grounds on the left hand fender bracket. Confirm the following:

- Ground bolts are “E” bolts (see Figures 5 and 7).
- Apron bolts should be “E” bolts if left hand fender bracket has been replaced (see Figures 5 and 7).
- The area around the bracket to apron mounting bolt holes (see Figure 6) is free of paint.
- The area around the apron mounting bolt holes do not show masking tape or painted masking tape (see Figures 5 and 6).

If ALL conditions above are met, continue with diagnosis using the applicable Repair Manual.

If ANY of the conditions above are NOT met, continue to step 11.

NOTICE

- Do NOT drive the vehicle or hook up the battery without proper "E" bolts in all 4 locations at apron and both grounds. The fender bracket must have a good ground path to prevent Engine Room Junction Block damage.
- Do NOT remove the fender bracket or grounds without first disconnecting the negative (-) battery cable.

Figure 5.

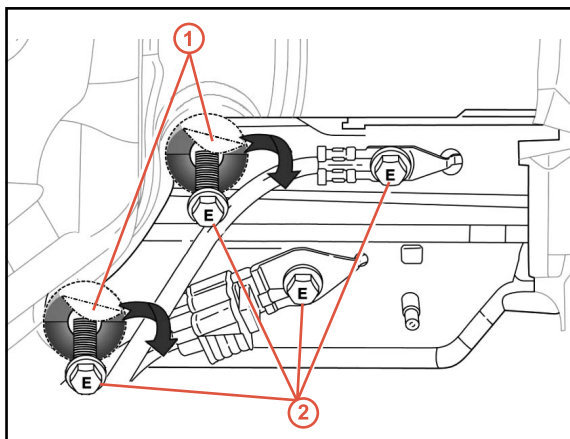

1	Confirm Green Masking Tape Is Removed
2	Confirm “E” Bolts Are Installed

Figure 6.

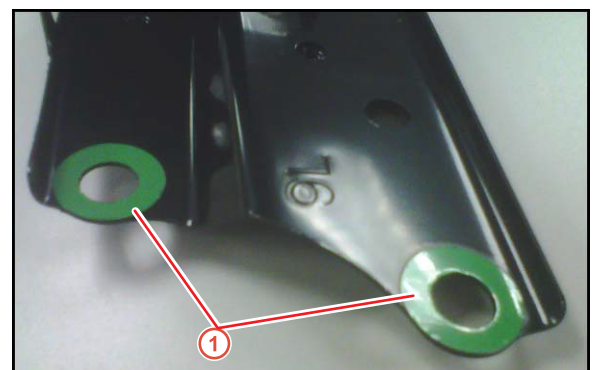

1	Masking Tape — REMOVE After Painting, NO Paint in This Area
----------	---

Integration Relay Poor Ground

Repair Procedure (Continued)

NOTE

- It is important that the bracket to apron mounting bolts/washers are free of paint on the front portion of the bracket.
- The new part number bracket comes with instructions that should be followed carefully when replacing.
- The new bracket also comes with green tape around the apron mounting bolts to protect it during the painting phase (see Figures 5 and 6). *This green masking tape MUST be removed in order for the bracket to be properly installed on the vehicle.*
- The new bracket includes new apron “E” mounting bolts. It is important that the new “E” bolts are used and are torqued properly. See Figure 7 on how to identify new bolts.

Torque: Ground Bolts:
 6.9 – 9.8 N*m (70 – 100 kgf*cm,
 5.1 – 7.2 ft*lbf)

Torque: Bracket to Apron Bolts:
 3.9 – 8.8 N*m (40 – 90 kgf*cm,
 2.8 – 6.5 ft*lbf)

Figure 7.

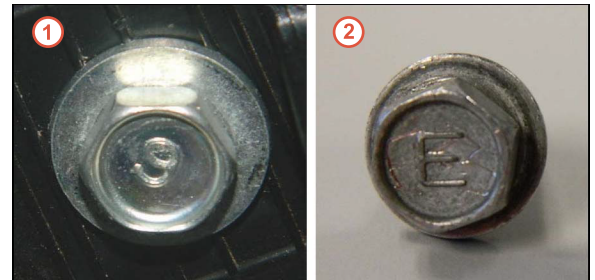

1	Old Bolt: DO NOT USE or Reuse These Bolts
2	NEW “E” Bolt

11. Is there masking tape or painted masking tape or paint around the apron bolt holes?
- **NO** — Replace the left hand fender bracket.
 - **YES** — Remove the tape or paint and continue to step 12.

NOTE

Apply cavity wax to apron bolts and area surrounding washers once bracket is completely installed.

12. Once areas are repaired and secured with new “E” bolts, replace the Engine Room Junction Block Assembly.

Integration Relay Poor Ground

Repair Procedure (Continued)

13. Reconnect battery, verify passenger headlight and rear defogger are OFF, then perform another voltage drop test from both ground wire tabs to a strut tower bolt and verify the voltage drop is less than 0.2 volts.

Is voltage drop less than 0.2 volts?

- **YES** — Continue to step 14.
- **NO** — Go back to step 10.

14. Reinstall front bumper cover and left headlight assembly.

Refer to TIS, applicable model and model year Repair Manual:

- Bumper Cover:

2013 [ES 350](#) / [ES 300h](#):

Vehicle Exterior – Exterior Panels/Trim – “Exterior Panels/Trim: Front Bumper: Installation”

- Left Headlight Assembly:

2013 [ES 350](#) / [ES 300h](#):

Vehicle Exterior – Lighting (ext) – “Lighting (Ext): Headlight Assembly: Installation”

15. Verify all affected systems work properly.