

# Power Back Door Inoperative

Service Category Vehicle Exterior

Section Door/Hatch

Market USA

Toyota Supports  
 ASE Certification 

## Applicability

YEAR(S)	MODEL(S)	ADDITIONAL INFORMATION
2014 - 2015	Highlander, Highlander HV	WMI(s): 5TD VDS(s): BCRFH, BKRFH, DCRFH, DKRFH, JCRFH, JKRFH, KKRFH, YKRFH, ZKRFH Plant Code(s): S

### **SUPERSESION NOTICE**

The information contained in this bulletin supersedes SB No. T-SB-0027-15.

- The entire bulletin has been updated.

Service Bulletin No. T-SB-0027-15. is Obsolete and any printed versions should be discarded. Be sure to review the entire content of this bulletin before proceeding.

## Introduction

Some 2014 – 2015 model year Highlander and Highlander HV vehicles may exhibit a condition in which the Power Back Door is inoperative or stops during operation. In some cases this condition may be associated with cold weather. Follow the Repair Procedure in this bulletin to address this condition.

## Power Back Door Inoperative

### Production Change Information

This bulletin applies to vehicles produced **BEFORE** the Production Change Effective VINs shown below.

MODEL	PLANT	DRIVETRAIN	PRODUCTION CHANGE EFFECTIVE VIN
Highlander	TMMI	2WD	5TDYKRFH#FS118557
			5TDKKRFH#FS118557
			5TDZKRFH#FS118557
		4WD	5TDDKRFH#FS221250
			5TDJKRFH#FS221250
			5TDBKRFH#FS221250
Highlander HV		HV	5TDDCRFH#FS013629
			5TDJCRFH#FS013629
			5TDBCRFH#FS013629

### Warranty Information

OP CODE	DESCRIPTION	TIME	OFF	T1	T2
BD1600	R & R Unit Assy Set, Power Back Door, RH & LH	0.6	68910-09020 68910-09021 68910-09030 68910-09031 68920-09020 68920-09021 68920-09030 68920-09031	9A	14
BD1600A	R & R Computer, Mutiplex Network Door	0.5	89222-0E080	9A	71

#### APPLICABLE WARRANTY

- This repair is covered under the Toyota Basic Warranty. This warranty is in effect for 36 months or 36,000 miles, whichever occurs first, from the vehicle's in-service date.
- Warranty application is limited to occurrence of the specified condition described in this bulletin.

## Power Back Door Inoperative

### Parts Information

**NOTE**

There is NO Power Back Door Unit Assembly service part number change specific to this countermeasure.

PART NUMBER		PART NAME	SPEC	QTY
68910-09021 or 68910-09022		Unit Assy Set, Power Back Door, RH	Without Subwoofer	1
68920-09021 or 68910-09051*		Unit Assy Set, Power Back Door, LH		1
68910-09031 or 68910-09040		Unit Assy Set, Power Back Door, RH	With Subwoofer	1
68920-09031 or 68910-09052*		Unit Assy Set, Power Back Door, LH		1
PREVIOUS	NEW	Computer, Multiplex Network Door	N/A	1
89222-0E080	89222-0E081			

\*Note usual 5 digit P/N supersession from 68920 to 68910 on Unit Assy Set, Power Back Door, LH.

### Required Tools & Equipment

SPECIAL SERVICE TOOLS (SST)	PART NUMBER	QTY
Plastic Pry Tool Kit*	<a href="#">00002-06020-01</a>	1

\* Essential SST.

**NOTE**

Additional SSTs may be ordered by calling 1-800-933-8335.

### Repair Procedure

1. Before proceeding with diagnosis, check the following:
  - A. Confirm the Power Back Door Main Switch (located in the glovebox) is turned on.
  - B. Set the power back door opening adjustment to position 5 (maximum opening position).

Refer to the Technical Information System (TIS), applicable model and model year Repair Manual:

- [2014 / 2015 Highlander](#):  
Vehicle Exterior – Door/Hatch – “Door/Hatch: Power Back Door System: Customize Parameters”
- [2014 / 2015 Highlander HV](#):  
Vehicle Exterior – Door/Hatch – “Door/Hatch: Power Back Door System: Customize Parameters”

## Power Back Door Inoperative

---

### Repair Procedure (Continued)

- C. Confirm hatch alignment and adjust or repair if necessary.  
Refer to TIS, applicable model and model year Repair Manual:
- [2014 / 2015 Highlander](#):  
*Vehicle Exterior – Door/Hatch – “Door/Hatch: Back Door: Adjustment”*
  - [2014 / 2015 Highlander HV](#):  
*Vehicle Exterior – Door/Hatch – “Door/Hatch: Back Door: Adjustment”*
- D. Confirm touch sensors are undamaged and operating normally

2. Operate the Power Back Door and attempt to duplicate the condition.

**NOTE**

Some failure modes occur only when the ambient temperature is below freezing. If the customer experienced the condition in cold weather, cold soak the vehicle outside overnight, then perform diagnosis in steps 2 – 4 (if required) before warming the vehicle in the shop.

- If the PBD begins to open or close, then stops, proceed to step 5.
  - If the PBD is inoperative (no movement in the closing direction, no movement beyond latch release in the opening direction), proceed to step 3.
3. Turn off the Power Back Door system using the main switch located in the glove compartment and attempt to operate the back door manually.
- If the door cannot be opened or closed manually, or if the force required to manually operate the door is abnormally high, proceed to step 5.
  - If manual operating effort is normal, and the ambient temperature was below freezing when the condition was duplicated, proceed to step 4.
  - If manual operating effort is normal, and the ambient temperature was above freezing when the condition was duplicated, STOP. This bulletin does NOT apply. Continue diagnosis using the applicable Repair Manual.

**NOTE**

The force required for manual operation may be higher in cold temperatures. If necessary, a similar vehicle can be used for comparison.

## Power Back Door Inoperative

---

### Repair Procedure (Continued)

4. Turn ON the Power Back Door system using the main switch located in the glove compartment. Remove the back door trim panel and use a heat gun to warm the Door Computer (Computer, Multiplex Network Door) for 2 - 3 minutes, then attempt to operate the Power Back Door.
  - If normal operation is restored, replace the Door Computer and proceed to step 7.
  - If there is no change to the condition, STOP. This bulletin does NOT apply. Continue diagnosis using the applicable Repair Manual.

Refer to TIS, applicable model and model year Repair Manual:

- [2014 / 2015](#) Highlander:  
*Vehicle Exterior – Door/Hatch – “Door/Hatch: Back Door Closer ECU: Removal”*
  - [2014 / 2015](#) Highlander HV:  
*Vehicle Exterior – Door/Hatch – “Door/Hatch: Back Door Closer ECU: Removal”*
  - [2014 / 2015](#) Highlander:  
*Vehicle Exterior – Door/Hatch – “Door/Hatch: Back Door Closer ECU: Installation”*
  - [2014 / 2015](#) Highlander HV:  
*Vehicle Exterior – Door/Hatch – “Door/Hatch: Back Door Closer ECU: Installation”*
5. Remove and replace the LH and RH power back door actuators (Unit Assy Set, Power Back Door). Refer to TIS, applicable model and model year Repair Manual:
    - [2014 / 2015](#) Highlander:  
*Vehicle Exterior – Door/Hatch – “Door/Hatch: Power Back Door Drive Unit: Removal”*
    - [2014 / 2015](#) Highlander HV:  
*Vehicle Exterior – Door/Hatch – “Door/Hatch: Power Back Door Drive Unit: Removal”*
    - [2014 / 2015](#) Highlander:  
*Vehicle Exterior – Door/Hatch – “Door/Hatch: Power Back Door Drive Unit: Installation”*
    - [2014 / 2015](#) Highlander HV:  
*Vehicle Exterior – Door/Hatch – “Door/Hatch: Power Back Door Drive Unit: Installation”*

## Power Back Door Inoperative

### Repair Procedure (Continued)

6. After installing the new Power Back Door actuators, confirm that the ball and socket joints (2 LH and 2 RH) are properly seated, and have approximately 1 mm of free-play as indicated in Figure 1.

To check for free-play: first push, then pull, then push again on the power back door actuator unit near each socket.

- If free-play is present, continue to step 7.
- If there is NO free-play as shown in Figure 2, the ball mount is not fully seated in the socket.

**Figure 1. Expected Free-Play Condition**

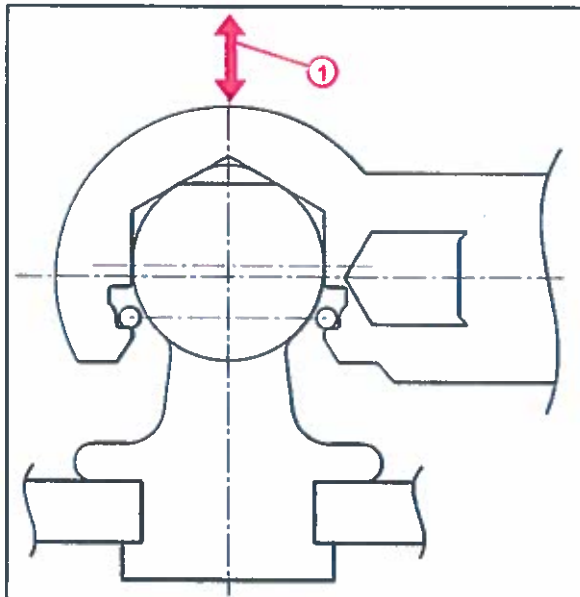

**1** 1 mm Free-Play: Ball Mount is Fully Seated in the Socket

**Figure 2. No Free-Play Condition**

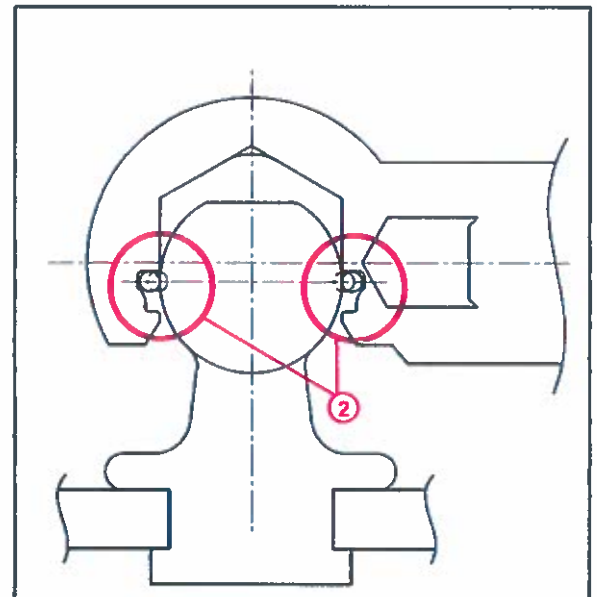

**2** No Free-Play: Ball Mount is Not Fully Seated in the Socket

### NOTICE

- If the ball mount is not fully seated in the socket mount separation may occur, which may cause damage to the vehicle.
- Attempt to seat the joint by pushing on the actuator near the socket. If free play cannot be achieved, replace the actuator and ball mounts with another new service part.

## Power Back Door Inoperative

---

### Repair Procedure (Continued)

7. Perform the Power Back Door initialization procedure.

Refer to TIS, applicable model and model year Repair Manual:

- [2014 / 2015](#) Highlander:  
*Vehicle Exterior – Door/Hatch – “Door/Hatch: Power Back Door System: Initialization”*
- [2014 / 2015](#) Highlander HV:  
*Vehicle Exterior – Door/Hatch – “Door/Hatch: Power Back Door System: Initialization”*

8. Confirm normal Power Back Door operation.

Refer to TIS, applicable model and model year Repair Manual:

- [2014 / 2015](#) Highlander:  
*Vehicle Exterior – Door/Hatch – “Door/Hatch: Power Back Door System: Operation Check”*
- [2014 / 2015](#) Highlander HV:  
*Vehicle Exterior – Door/Hatch – “Door/Hatch: Power Back Door System: Operation Check”*

