



TOYOTA Camry/Camry HV

2016 PRE-DELIVERY SERVICE CHECK SHEET

August 2015

BEFORE INSPECTION	OK	Adjust/Repair
1 Install Short Pin* (Hawaii, Puerto Rico, Saipan, Guam, American Samoa)	<input type="checkbox"/>	
FUNCTIONAL OPERATION		
<i>Apply parking brake and cycle ignition "IG-ON"; place gear selector in reverse; turn on lights and rear defogger. Unlock all doors, release fuel door, release trunk hatch.</i>		
1 Check dome, courtesy, map, and sun visor lights*	<input type="checkbox"/>	<input type="checkbox"/>
2 Check warning/indicator lights, gauges, and horn	<input type="checkbox"/>	<input type="checkbox"/>
3 Check windshield wipers and washer	<input type="checkbox"/>	<input type="checkbox"/>
4 Check headlights, instrument lights, turn signals, emergency flashers, and brake lights	<input type="checkbox"/>	<input type="checkbox"/>
5 Check inside/outside rear view mirror operation/adjustment*	<input type="checkbox"/>	<input type="checkbox"/>
6 Check cigarette lighter* and power outlets	<input type="checkbox"/>	<input type="checkbox"/>
7 Check audio/navigation*/backup camera systems and set clock	<input type="checkbox"/>	<input type="checkbox"/>
8 Check sliding roof*	<input type="checkbox"/>	<input type="checkbox"/>
9 Install shift-lock override button cover (key slot oriented along LEFT side of cover, at 9 o'clock position)	<input type="checkbox"/>	
WALKAROUND INSPECTION		
<i>Start at left front door. Check window and door lock operation (from master power switch, if equipped). Continue around vehicle in a counterclockwise direction checking each door and window operation, child door locks, seat belts, interior condition, all lights, luggage compartment contents. Finish by checking headlight aim and continue into UNDER HOOD checks.</i>		
1 Check Smart Key System	<input type="checkbox"/>	<input type="checkbox"/>
2 Check door and door lock operation, including each wireless remote control/theft deterrent system*	<input type="checkbox"/>	<input type="checkbox"/>
3 Check window operation	<input type="checkbox"/>	<input type="checkbox"/>
4 Check that engine starts with all keys	<input type="checkbox"/>	<input type="checkbox"/>
5 Check that child safety door locks are in normal (unlocked) position	<input type="checkbox"/>	<input type="checkbox"/>
6 Check seats and seat belt operation	<input type="checkbox"/>	<input type="checkbox"/>
7 Check rear defogger/rear view mirror defogger*	<input type="checkbox"/>	<input type="checkbox"/>
8 Check side marker, tail, backup, and license plate lights	<input type="checkbox"/>	<input type="checkbox"/>
9 Check luggage compartment light* and trim appearance	<input type="checkbox"/>	<input type="checkbox"/>
10 Adjust spare tire pressure, inspect for damage, and check jack and tool installation	<input type="checkbox"/>	<input type="checkbox"/>
11 Check headlight aim	<input type="checkbox"/>	<input type="checkbox"/>
UNDER HOOD		
1 Check engine oil level	<input type="checkbox"/>	<input type="checkbox"/>
2 Check brake fluid level	<input type="checkbox"/>	<input type="checkbox"/>
3 Check engine coolant level	<input type="checkbox"/>	<input type="checkbox"/>
4 Check inverter coolant level*	<input type="checkbox"/>	<input type="checkbox"/>
5 Check windshield washer fluid level	<input type="checkbox"/>	<input type="checkbox"/>
6 Check battery state-of-charge using Digital Battery System Analyzer (SOC Reading: _____%)	<input type="checkbox"/>	<input type="checkbox"/>
7 Inspect for fuel, oil, coolant, and other fluid leaks	<input type="checkbox"/>	<input type="checkbox"/>
BATTERY MAINTENANCE*		
1 Perform HV battery check and maintenance	<input type="checkbox"/>	<input type="checkbox"/>
* Inspect or install when equipped/required.		

UNDER VEHICLE (ON HOIST)	OK	Adjust/Repair
1 Remove disc brake anti-rust covers/anti-corrosion wheel film*	<input type="checkbox"/>	
2 Inspect tires for defects/damage	<input type="checkbox"/>	<input type="checkbox"/>
3 Initialize or verify Tire Pressure Warning System (TPWS) operation (select appropriate procedure on page 2)	<input type="checkbox"/>	
4 Install wheel covers/caps/spare tire wheel covers*	<input type="checkbox"/>	<input type="checkbox"/>
5 Check hybrid transmission fluid level*	<input type="checkbox"/>	<input type="checkbox"/>
6 Inspect for fuel, oil, coolant, and other fluid leaks	<input type="checkbox"/>	<input type="checkbox"/>
7 Inspect under the vehicle for damage, rust, etc	<input type="checkbox"/>	<input type="checkbox"/>
8 Visually check bolts and nuts on chassis and powertrain for looseness	<input type="checkbox"/>	<input type="checkbox"/>
9 Install rubber body plugs (stored in glove box or center console)*	<input type="checkbox"/>	
10 Install front wheel opening extension pads (See page 2)	<input type="checkbox"/>	
ROAD TEST		
<i>A complete road test helps assure customer satisfaction. Drive vehicle over a variety of road surfaces and driving conditions. Check for unusual noise and driving performance.</i>		
Enter Odometer Readings		
Reading Before Test: _____ Reading After Test: _____		
1 Check cold engine operation	<input type="checkbox"/>	<input type="checkbox"/>
2 Check engine operation during warm-up	<input type="checkbox"/>	<input type="checkbox"/>
3 Check engine at normal operating temperature	<input type="checkbox"/>	<input type="checkbox"/>
4 Check transmission operation	<input type="checkbox"/>	<input type="checkbox"/>
5 Check brake and parking brake operation	<input type="checkbox"/>	<input type="checkbox"/>
6 Check steering operation and off-center/vehicle pull/flutter	<input type="checkbox"/>	<input type="checkbox"/>
7 Inspect for abnormal noise and vibration	<input type="checkbox"/>	<input type="checkbox"/>
8 Inspect for squeaks and rattles	<input type="checkbox"/>	<input type="checkbox"/>
9 Check Blind Spot Monitor System*	<input type="checkbox"/>	<input type="checkbox"/>
10 Check front and rear* heater and A/C operation	<input type="checkbox"/>	<input type="checkbox"/>
11 Check cruise control operation*	<input type="checkbox"/>	<input type="checkbox"/>
12 Check front seat heater/ventilation operation*	<input type="checkbox"/>	<input type="checkbox"/>
13 Set/calibrate compass* (see page 2)	<input type="checkbox"/>	<input type="checkbox"/>
FINAL INSPECTION AND CLEANING		
1 Remove interior protective covers, unnecessary labels, tags, etc. (Remove just before delivery to customer)	<input type="checkbox"/>	
2 Visually inspect all interior parts for installation, damage, fit, dirt, etc.	<input type="checkbox"/>	<input type="checkbox"/>
3 Verify floor mat application and install using retaining clips*	<input type="checkbox"/>	<input type="checkbox"/>
4 Verify green light is illuminated on SOS (Safety Connect) button*	<input type="checkbox"/>	<input type="checkbox"/>
5 Remove Rapgard™ and clear protective bumper film*	<input type="checkbox"/>	<input type="checkbox"/>
6 Wash and clean vehicle	<input type="checkbox"/>	<input type="checkbox"/>
7 Inspect paint finish for scratches, chips, rust, dents, damage, etc.	<input type="checkbox"/>	<input type="checkbox"/>
8 Inspect exterior body parts for proper installation, damage, rust, etc.	<input type="checkbox"/>	<input type="checkbox"/>
9 Place oil change sticker on inside of windshield, top left corner	<input type="checkbox"/>	
10 Place Owner's Guide and first aid kit portfolio* in glove box	<input type="checkbox"/>	
11 Perform Techstream Health Check	<input type="checkbox"/>	<input type="checkbox"/>
12 Install front license plate and mounting bracket* (page 2)	<input type="checkbox"/>	

Completion and retention of this form is required to comply with Toyota's Warranty Policy.

TECHNICIAN'S SIGNATURE

SERVICE MANAGER'S SIGNATURE

NAME (PLEASE PRINT)

NAME (PLEASE PRINT)

We hereby certify that all items on this form have been checked and corrected for proper operation as required.

Date

Dealer Name

Dealer Code

Vehicle Identification Number (Sticker)

TPWS INITIALIZATION (for models equipped with a RESET switch)

Refer to the Repair Manual for the initialization procedure ([Camry / Camry HV](#)). Please note the spare tire does not have a TPWS sensor.

NOTE

To adjust the tire pressure correctly when the outside temperature is significantly colder than shop temperature, perform a Health Check using Techstream and select the "Compensation Tire Pressure" checkbox. Compensation pressures will be displayed on the Health Check results screen. Adjust the tire pressure when the tires are cold.

TPWS OPERATION VERIFICATION (ONLY for LE models *without* a RESET switch)

1. Connect Techstream to DLC3.
2. Adjust all tires (except the spare tire) to the standard tire inflation pressure, as indicated on the tire and loading information label on the vehicle.

NOTE

To adjust the tire pressure correctly when the outside temperature is significantly colder than shop temperature, perform a Health Check using Techstream and select the "Compensation Tire Pressure" checkbox. Compensation pressures will be displayed on the Health Check results screen. Adjust the tire pressure when the tires are cold.

3. Cycle the ignition switch to the "IG-ON" mode.
4. Check the tire pressure of all tires using Techstream. If the tire pressure values cannot be displayed, the system is NOT operating properly. Refer to the Repair Manual.

FRONT WHEEL OPENING EXTENSION PAD INSTALLATION

The front wheel opening extension pad set (right and left front wheel opening extension pads and 2 tapping screws) is loaded in the luggage compartment at the assembly plant to avoid damage in transit.

NOTE

Note the color of the bag inside the packaged set and continue the procedure

1. Verify that the color of the bag and P/N of the pads are applicable to the engine type of the vehicle.
 - V6 Engine: Yellow bag (P/N 53853-06040)
 - I4 Engine: Green bag (P/N 53853-06100)
2. Remove the 2 tapping screws from the engine under cover (the screws will be reused for installation).
3. Place the left front wheel opening extension pad on the installation position as shown and tighten the 3 tapping screws.

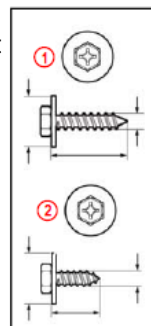

1 Screw A

2 Screw B

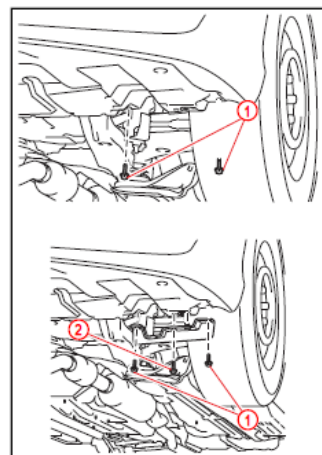

Tapping Screws A:

Nominal Length: 23.0 mm (0.91 in.)

Diameter: 6.0 mm (0.24 in)

Washer Outside Diameter: 18.0 mm (0.71 in.)

Tapping Screws B:

Nominal Length: 16.0 mm (0.63 in.)

Diameter: 6.0 mm (0.24 in)

Washer Outside Diameter: 20.0 mm (0.79 in.)

NOTE

- Ensure correct pads are used for appropriate vehicle.
- There is a distinguishable mark indicating left and right on each pad.
- Do NOT interchange the tapping screws A and B.

4. Repeat steps 1 through 3 for the right side

COMPASS CALIBRATION

Refer to the Repair Manual for the Calibration procedure ([Camry/Camry HV](#)) for vehicles equipped with a compass in the rear view mirror.

NOTE

- Do NOT perform calibration of the compass in a place where the Earth's magnetic field is subject to interference (underground parking, under a steel tower, between buildings, roof parking, near a railroad crossing, near a large vehicle, etc.).
- During calibration, do NOT operate electric systems (moon roof, power windows, etc.) as they may interfere with the calibration.

FRONT LICENSE PLATE & MOUNTING BRACKET INSTALLATION*

Installation procedure

1. Position the front license plate mounting bracket over the lower grille.
2. Align the installation holes on the mounting bracket with the dimples on the front of the lower grille.
3. Screw in the 4 long self-tapping screws through the slotted and round holes of the mounting bracket, directly into the dimples on the lower grille.
4. Insert license plate into tabs on the bracket.
5. Align the top holes of the license plate with the rounded holes of the mounting bracket
6. Screw in 2 short self-tapping screws through the license plate holes into the mounting bracket.

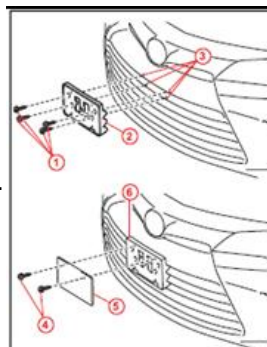

Short Self-tapping Screw: 20 mm (0.787 in)

Long Self-tapping Screw: 37 mm (1.456 in)

- 1 Long Self-tapping Screws
- 2 Front License Plate Mounting Brackets
- 3 Dimples
- 4 Short Self-tapping Screws
- 5 License Plate
- 6 Front License Plate Mounting Bracket

NOTICE

- Do NOT pre-drill holes into the **bumper** or **mounting bracket**
- Do NOT overtighten the self-tapping screws.