

April 7, 2018

08696 Version 5

Product Update: TLX 9-Speed Transmission Warmer (Transmission Previously Replaced for Transmission Warmer Leaking)

Supersedes 17-011, dated October 18, 2017, to revise the information highlighted in **yellow**

AFFECTED VEHICLES

Year	Model	Trim	VIN Range
2015–16	TLX	All with 9-speed A/T	Check the iN VIN status for eligibility

REVISION SUMMARY

Under PARTS INFORMATION – REPAIR PROCEDURE B, parts quantity was changed and parts were added.

Under PARTS INFORMATION – REPAIR PROCEDURE D, parts quantity was changed and parts were added.

BACKGROUND

Some 9-speed transmission warmers were improperly manufactured and allow the engine coolant and ATF to mix. If the fluids mix, the engine and transmission may be permanently damaged and require replacement. These vehicles previously had the transmission replaced because the transmission warmers leaked. In rare cases, these vehicles may have also overheated but because the issue was under investigation, a standard repair procedure hadn't been developed. Further action is needed before the vehicle is completely repaired.

Make sure you review this bulletin in its entirety before starting. There are multiple repairs available, and the correct one for the vehicle you are working on is based on your inspection and customer interview responses.

CLIENT NOTIFICATION

Owners of affected vehicles will be sent a notification of this campaign.

Do an iN VIN status inquiry to make sure the vehicle is shown as eligible.

Some vehicles affected by this campaign may be in your new or used vehicle inventory. Repair these vehicles before they are sold.

SERVICE ADVISOR

Ask the client if the vehicle overheated, for example, if the MID showed a message **Stop Driving Engine Temperature Too Hot** or there was steam from under the hood. Other signs include coolant leaking from the radiator cap or the coolant reserve tank.



OR



The vehicles in this campaign had the transmission previously replaced. The vehicle may have overheated due to the warmer leaking on the previous repair; ask the customer if the vehicle overheated before the transmission was replaced. This will help your technician decide what repair needs to be done.

Write down the client responses on the RO.

CLIENT INFORMATION: The information in this bulletin is intended for use only by skilled technicians who have the proper tools, equipment, and training to correctly and safely maintain your vehicle. These procedures should not be attempted by "do-it-yourselfers," and you should not assume this bulletin applies to your vehicle, or that your vehicle has the condition described. To determine whether this information applies, contact an authorized Acura automobile dealer.

NOTE: Any engine replaced without this documentation on the signed RO will be subject to debit.

CORRECTIVE ACTION

Inspect the warmer, and based on your inspection and interview with the customer, do one of the following:

- Replace the transmission warmer, replace the radiator, coolant hoses, thermostat, coolant reserve tank, 2 ECT sensor (1 and 2) O-rings, and flush the cooling system.
- Replace the transmission, radiator, coolant hoses, thermostat, coolant reserve tank, 2 ECT sensor (1 and 2) O-rings, and flush the cooling system.
- Replace the short block, cylinder heads, radiator, thermostat, coolant reserve tank, all of the coolant hoses, 2 ECT sensor (1 and 2) O-rings, water passage, water connecting pipe, and flush the heater core.
- Replace the radiator, coolant hoses, thermostat, coolant reserve tank, 2 ECT sensor (1 and 2) O-rings, and flush the cooling system.
- Replace the short block, cylinder heads, transmission, radiator, thermostat, coolant reserve tank, all of the coolant hoses, 2 ECT sensor (1 and 2) O-rings, water passage, water connecting pipe, and flush the heater core.

The flowchart below provides a summary to help navigate the inspection and repair procedure. Make sure you read the service bulletin steps thoroughly for the detailed repair information.

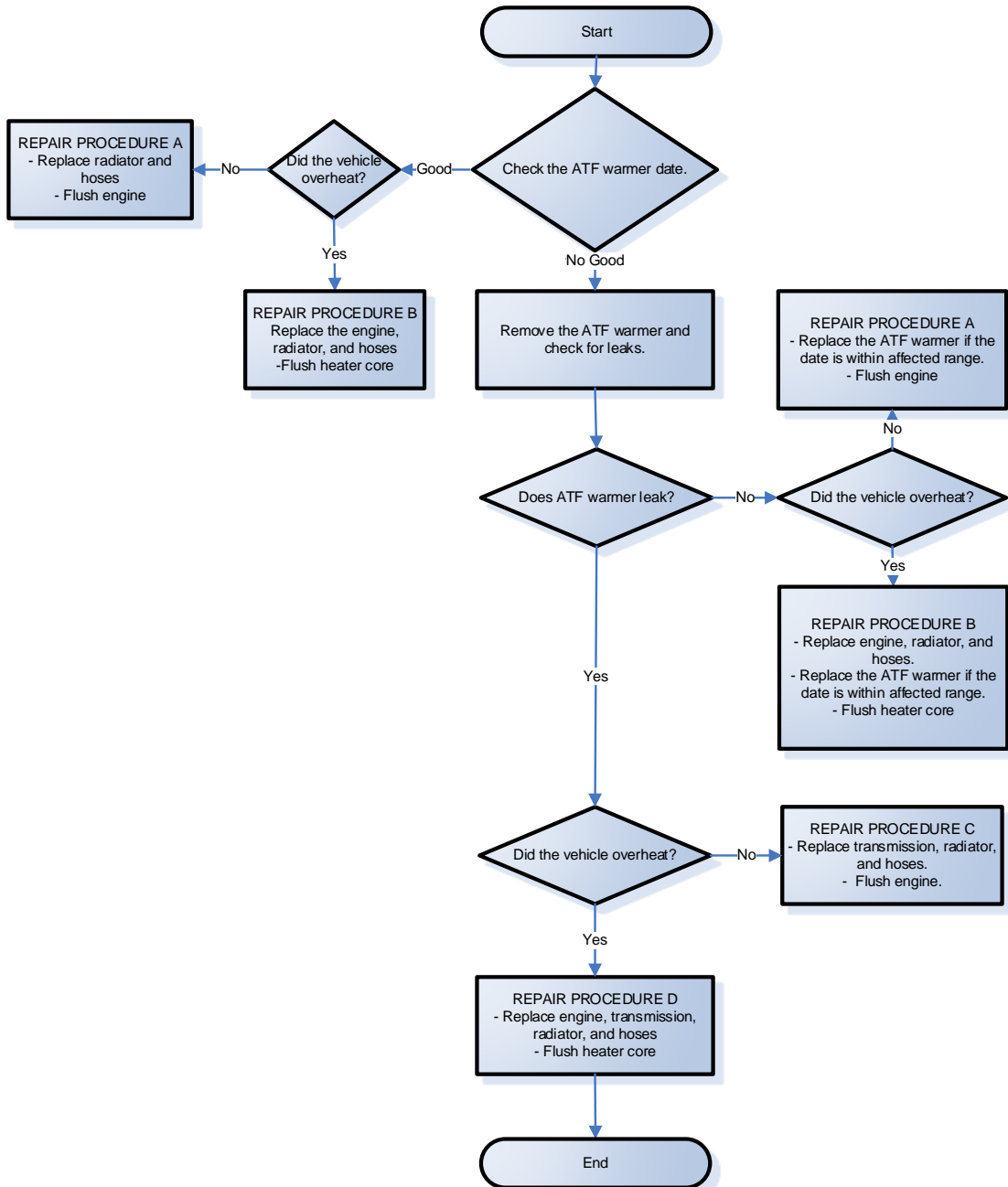

WARRANTY CLAIM INFORMATION

NOTE: Very few engine blocks should be replaced because of overheating. Replaced engine blocks may be called in to validate damage to the original block.

Inspection and REPAIR PROCEDURE A

Operation Number	Description	Flat Rate Time	Defect Code	Symptom Code	Template ID	Failed Part Number
2185B5	Inspect the ATF warmer manufacture date, check vehicle for overheating and do REPAIR PROCEDURE A - Replace radiator and hoses - Flush engine	3.7 hr	6ZF00	KG500	B17012A	06200-5J4-A71
2185B5	Inspect the ATF warmer manufacture date, check vehicle for overheating and do REPAIR PROCEDURE A - Replace radiator and hoses - Flush engine	3.7 hr	6ZF00	KG500	B17012B	06200-5J4-A71
A	Add if ATF warmer tested because of manufacture date. - Replace ATF warmer	2.1 hr				

Inspection and REPAIR PROCEDURE B

Operation Number	Description	Flat Rate Time	Defect Code	Symptom Code	Template ID	Failed Part Number
2185B6	2WD BASE/TECH - Inspect the ATF warmer manufacture date, check vehicle for overheating and do REPAIR PROCEDURE B -Replace engine, radiator, and hoses - Flush heater core - Includes updating PCM/TCM, idle learn and alignment	11.8 hr	6ZF00	KG500	B17012C	06200-5J4-A71
2185B6	2WD ADV - Inspect the ATF warmer manufacture date, check vehicle for overheating and do REPAIR PROCEDURE B -Replace engine, radiator, and hoses - Flush heater core - Includes updating PCM/TCM, idle learn and alignment	11.8 hr	6ZF00	KG500	B17012D	06200-5J4-A71
A	Add if ATF warmer tested and replaced because of manufacture date.	0.9 hr				
2185B7	AWD BASE/TECH - Inspect the ATF warmer manufacture date, check vehicle for overheating and do REPAIR PROCEDURE B - Replace engine, radiator, and hoses - Flush heater core - Includes updating PCM/TCM, idle learn and alignment	12.2 hr	6ZF00	KG500	B17012E	06200-5J4-A71
2185B7	AWD ADV - Inspect the ATF warmer manufacture date, check vehicle for overheating and do REPAIR PROCEDURE B - Replace engine, radiator, and hoses - Flush heater core - Includes updating PCM/TCM, idle learn and alignment	12.2 hr	6ZF00	KG500	B17012F	06200-5J4-A71
A	Add if ATF warmer tested and replaced because of manufacture date.	0.9 hr				

Inspection and REPAIR PROCEDURE C

NOTE:

- Very few engine blocks should be replaced because of overheating. Replaced engine blocks may be called in to validate damage to the original block.
- Replacement of the engine block and/or transmission requires DPSM authorization.

Operation Number	Description	Transmission Replacement Number	Flat Rate Time	Defect Code	Symptom Code	Template ID	Failed Part Number
2185B8	2WD BASE/TECH - Inspect the ATF warmer manufacture date and check vehicle for overheating and do REPAIR PROCEDURE C - Replace transmission, radiator, and hoses -Flush engine - Includes updating PCM/TCM, idle learn and alignment	06200-5J4-A71RM	10.5 hr	6ZF00	KG500	B17012G	06200-5J4-A71
2185B8	2WD ADV - Inspect the ATF warmer manufacture date and check vehicle for overheating and do REPAIR PROCEDURE C - Replace transmission, radiator, and hoses -Flush engine - Includes updating PCM/TCM, idle learn and alignment	06200-5J4-A81RM	10.5 hr	6ZF00	KG500	B17012H	06200-5J4-A71
2185B9	AWD BASE/TECH - Inspect the ATF warmer manufacture date and check vehicle for overheating and do REPAIR PROCEDURE C - Replace transmission, radiator, and hoses -Flush engine - Includes updating PCM/TCM, idle learn and alignment	06200-5L9-A72RM	10.9 hr	6ZF00	KG500	B17012I	06200-5J4-A71
2185B9	AWD ADV - Inspect the ATF warmer manufacture date and check vehicle for overheating and do REPAIR PROCEDURE C - Replace transmission, radiator, and hoses -Flush engine - Includes updating PCM/TCM, idle learn and alignment	06200-5L9-A81RM	10.9 hr	6ZF00	KG500	B17012J	06200-5J4-A71

Inspection and REPAIR PROCEDURE D

NOTE:

- Very few engine blocks should be replaced because of overheating. Replaced engine blocks may be called in to validate damage to the original block.
- Replacement of the engine block and/or transmission requires DPSM authorization.

Operation Number	Description	Transmission Replacement Number	Flat Rate Time	Defect Code	Symptom Code	Template ID	Failed Part Number
2185C4	<p>2WD BASE/TECH - Inspect the ATF warmer manufacture date and check vehicle for overheating and do REPAIR PROCEDURE D</p> <p>-Replace engine, transmission, radiator, and hoses</p> <p>-Flush heater core</p> <p>- Includes updating PCM/TCM, idle learn and alignment</p>	06200-5J4-A71RM	12.7 hr	6ZF00	KG500	B17012K	06200-5J4-A71
2185C4	<p>2WD ADV - Inspect the ATF warmer manufacture date and check vehicle for overheating and do REPAIR PROCEDURE D</p> <p>-Replace engine, transmission, radiator, and hoses</p> <p>-Flush heater core</p> <p>- Includes updating PCM/TCM, idle learn and alignment</p>	06200-5J4-A81RM	12.7 hr	6ZF00	KG500	B17012L	06200-5J4-A71

Inspection and REPAIR PROCEDURE D

2185C5	<p>AWD BASE/TECH - Inspect the ATF warmer manufacture date and check vehicle for overheating and do REPAIR PROCEDURE D</p> <ul style="list-style-type: none"> -Replace engine, transmission, radiator, and hoses -Flush heater core - Includes updating PCM/TCM, idle learn and alignment 	06200-5L9-A72RM	13.1 hr	6ZF00	KG500	B17012M	06200-5J4-A71
2185C5	<p>AWD ADV - Inspect the ATF warmer manufacture date and check vehicle for overheating and do REPAIR PROCEDURE D</p> <ul style="list-style-type: none"> -Replace engine, transmission, radiator, and hoses -Flush heater core - Includes updating PCM/TCM, idle learn and alignment 	06200-5L9-A81RM	13.1 hr	6ZF00	KG500	B17012N	06200-5J4-A71

PARTS INFORMATION – WARMER INSPECT AND REPLACEMENT

Part Name	Part Number	Quantity
ATF Warmer Kit (Includes O-Rings)	06224-5J4-305	1

REQUIRED MATERIALS – ATF WARMER INSPECTION AND REPLACEMENT

Part Name	Part Number	Quantity
ATF Type 3.1 NOTE: 1 quart will fill 5 vehicles.	08200-9017	1

NOTE: Order the Honda ATF for this campaign.

PARTS INFORMATION – REPAIR PROCEDURE A

Part Name	Part Number	Quantity
Radiator (DENSO)	19010-5J2-A01	1
Reserve Tank	19101-5J2-A00	1
Reserve Tank Cap	19102-5J6-A00	1
Reserve Tank Joint	19106-RSA-G00	1
Reserve Tank Tube A	19103-5J2-A00	1
Reserve Tank Tube B	19104-5J2-A00	1
Water Hose (Lower) (A)	19502-5J2-A50	1
Water Hose (Lower) (B)	19504-5J2-A50	1
Water Hose (Upper)	19501-5J2-A00	1
Water Inlet Hose	79721-TZ3-A00	1
Water Outlet Hose Assembly	79725-TZ3-A00	1
Warmer Hose B (ATF)	19433-5J2-A00	1
Water Hose B	19522-R9P-A00	1
Water Hose C	19523-5J2-A00	1
Water Hose A	19521-5J2-A00	1
Warmer Hose A (ATF)	19432-5J2-A50	1
O-Ring (DENSO)	91307-RTA-005	2
Thermostat Cover Assembly	19315-5J2-A01	1

REQUIRED MATERIALS – REPAIR PROCEDURE A

Part Name	Part Number	Quantity
Coolant Type 2	OL999-9011A	16

PARTS INFORMATION – REPAIR PROCEDURE B

Part Name	Part Number	Quantity
Cylinder Block Assembly	10002-5J2-A00	1
Cylinder Head Assembly (Front)	10004-R9P-A01	1
Cylinder Head Assembly (Rear)	10005-5J6-A00	1
Exhaust Pipe Gasket (ISHINO)	18212-SA7-003	2
Pre-Chamber Gasket	18393-SDB-A00	1
Self-Lock Nut (10 mm)	90212-SA5-003	9
Bolt (12 point 8 x 21 mm) (AWD Only)	90113-S10-000	8
Washer Bolt (10 x 30 mm) (AWD Only)	90382-SZA-003	2
Split Pin (3.0 x 22 mm)	94201-30220	2
Castle Nut (14 mm)	90363-S3V-A01	2
Spindle Nut (24 mm)	90305-SD4-003	2
Flange Nut (12 mm)	90371-SEF-000	4
Flange Bolt (10 x 35 mm)	90163-SDA-A01	1
Flange Bolt (10 x 45 mm)	90163-TZ3-A00	1
Flange Bolt (10 x 60 mm)	90168-TA1-A00	2
Flange Bolt (12 x 45 mm)	90165-SDA-A00	2
Flange Bolt (12 x 45 mm)	90164-T2G-A01	1
Flange Bolt (10 x 30 mm)	90163-SDB-A00	3
Flange Bolt (12 x 56 mm)	90170-TZ3-A00	4
Flange Bolt (10 x 50 mm)	95701-10050-08	4
Intake Manifold Cover Gasket (Upper)	17112-5G0-A01	1
Intake Manifold Gasket (NIPPON LEAKLESS)	17105-R9P-A01	1
Throttle Body Gasket	16176-RYE-A10	1
Fuel Joint Pipe Set (MSDS includes VOC)	16012-R9P-305	1
Front Intake Manifold Base Gasket	17055-R9P-A01	1
Rear Intake Manifold Base Gasket	17065-R9P-A01	1
Injector Seal Set	16453-R9P-A00	2
O-Ring	91311-5A2-A01	1
Exhaust Chamber Gasket (NIPPON LEAKLESS)	18115-5G0-A01	2
EGR Pipe Gasket A	18716-R70-A01	1
EGR Pipe Gasket B	18719-R70-A01	1

Rear Cylinder Head Gasket (NIPPON LEAKLESS)	12261-R9P-A01	1
Front Cylinder Head Gasket (NIPPON LEAKLESS)	12251-R9P-A01	1
Timing Belt Idler Bolt	14551-RCA-A01	1
Front Water Passage Gasket (NIPPON LEAKLESS)	19411-5G0-A02	1
Rear Water Passage Gasket (NIPPON LEAKLESS)	19412-5G0-A01	1
O-Ring (Denso)	91307-RTA-005	2
Thermostat Cover Assembly	19315-5J2-A01	1
O-Ring (31.2 x 4.1 mm) (NOK)	91314-PH7-003	2
EGR Valve Gasket (ISHINO GASKET)	18715-PB2-000	1
Oil Filter	15400-PLM-A02	1
Radiator (DENSO)	19010-5J2-A01	1
Reserve Tank	19101-5J2-A00	1
Reserve Tank Cap	19102-5J6-A00	1
Reserve Tank Joint	19106-RSA-G00	1
Reserve Tank Tube A	19103-5J2-A00	1
Reserve Tank Tube B	19104-5J2-A00	1
Water Hose (Lower) (A)	19502-5J2-A50	1
Water Hose (Lower) (B)	19504-5J2-A50	1
Water Hose (Upper)	19501-5J2-A00	1
Water Inlet Hose	79721-TZ3-A00	1
Water Outlet Hose Assembly	79725-TZ3-A00	1
Warmer Hose B (ATF)	19433-5J2-A00	1
Water Hose B	19522-R9P-A00	1
Water Hose C	19523-5J2-A00	1
Water Hose A	19521-5J2-A00	1
Warmer Hose A (ATF)	19432-5J2-A50	1
Connecting Pipe	19505-5J2-A00	1
Water Passage	19410-5J2-A00	1
Flange Bolt (12 x 70 mm)	90051-R97-000	1
Flange Bolt (12 x 120 mm)	90051-5J4-000	1
Flange Bolt (10 x 30 mm)	90161-T2F-A01	3
Flange Bolt (10 x 45 mm)	90163-SZ3-000	3
Flange Bolt (14 x 135 mm)	90176-SDA-A00	2
Flange Bolt (10 x 77 mm)	90167-TZ7-A01	2
Flange Bolt (10 x 24 mm)	90166-TZ7-A01	2

Flange Bolt (14 x 150 mm)	90177-SDA-A00	2
Bolt Washer (8 x 16 mm)	90101-SWA-A00	2
Flange Bolt (12 x 33 mm)	90186-SDA-A00	2
Flange Bolt (10 x 34 mm)	90162-T2A-A00	4
Snap Ring (32 x 2.2 mm)	44319-STX-A01	1
Set Ring (32 x 2.2 mm)	44319-STX-A60	1
Spindle Nut	90305-S3V-A11	2
Injector Clip	16451-5A2-A01	6
Sealing Washer (12 mm)	16705-5A2-A01	2

REQUIRED MATERIALS – REPAIR PROCEDURE B

Part Name	Part Number	Quantity
Coolant Type 2	OL999-9011A	3
Acura motor oil 0W-20	08798-9073	6

PARTS INFORMATION - REPAIR PROCEDURE C

Part Name	Part Number	Quantity
Transmission		1
2WD Base and Tech	06200-5J4-A71RM	
2WD Advanced	06200-5J4-A81RM	
AWD Base and Tech	06200-5L9-A72RM	
AWD Advanced	06200-5L9-A81RM	
Flange Bolt (12 x 70 mm)	90051-R97-000	1
Flange Bolt (12 x 120 mm)	90051-5J4-000	1
Flange Nut (12 mm)	90371-SEF-000	4
Flange Bolt (10 x 35 mm)	90163-SDA-A01	1
Flange Bolt (10x 45 mm)	90163-TZ3-A00	1
Flange Bolt (10 x 30 mm)	90161-T2F-A01	3
Flange Bolt (12 x 45 mm)	90165-SDA-A00	2
Flange Bolt (12 x 45 mm)	90164-T2G-A01	1
Pre-Chamber Gasket	18393-SDB-A00	2
Exhaust Pipe Gasket (NOK)	18212-SA7-003	2
Self-Lock Nut (10 mm)	90212-SA5-003	9
Bolt (12 point 8 x 21 mm)	90113-S10-000	8
Washer Bolt (10 x 30 mm)	90382-SZA-003	2
Split Pin (3.0 x 22 mm)	94201-30220	2
Castle Nut (14 mm)	90363-S3V-A01	2
Flange Bolt (10 x 45 mm)	90163-SZ3-000	3
Flange Bolt (14 x 135 mm)	90176-SDA-A00	2
Flange Bolt (10 x 77 mm)	90167-TZ7-A01	2
Flange Bolt (10 x 24 mm)	90166-TZ7-A01	2
Flange Bolt (14 x 150 mm)	90177-SDA-A00	2
Flange Bolt (8 x 16 mm)	90101-SWA-A00	2
Flange Bolt (12 x 33 mm)	90186-SDA-A00	2
Flange Bolt (10 x 34 mm)	90162-T2A-A00	4
Snap Ring (32 x 2.2 mm)	44319-STX-A01	1
Set Ring (32 x 2.2 mm)	44319-STX-A60	1
Flange Bolt (10 x 30 mm)	90163-SDB-A00	3
Radiator (DENSO)	19010-5J2-A01	1
Reserve Tank	19101-5J2-A00	1
Reserve Tank Cap	19102-5J6-A00	1
Reserve Tank Joint	19106-RSA-G00	1
Reserve Tank Tube A	19103-5J2-A00	1
Reserve Tank Tube B	19104-5J2-A00	1
Water Hose (Lower) (A)	19502-5J2-A50	1

Water Hose (Lower) (B)	19504-5J2-A50	1
Water Hose (Upper)	19501-5J2-A00	1
Water Inlet Hose	79721-TZ3-A00	1
Water Outlet Hose Assembly	79725-TZ3-A00	1
Warmer Hose B (ATF)	19433-5J2-A00	1
Water Hose B	19522-R9P-A00	1
Water Hose C	19523-5J2-A00	1
Water Hose A	19521-5J2-A00	1
Warmer Hose A (ATF)	19432-5J2-A50	1
O-Ring (DENSO)	91307-RTA-005	2
Thermostat Cover Assembly	19315-5J2-A01	1
Spindle Nut	90305-S3V-A11	2

REQUIRED MATERIALS – REPAIR PROCEDURE C

Part Name	Part Number	Quantity
ATF Type 3.1 NOTE: 1 quart will fill 5 vehicles.	08200-9017	1
Coolant Type 2	OL999-9011A	12

NOTE: Order the Honda ATF for this campaign.

PARTS INFORMATION – REPAIR PROCEDURE D

Part Name	Part Number	Quantity
Transmission		1
2WD Base and Tech	06200-5J4-A71RM	
2WD Advanced	06200-5J4-A81RM	
AWD Base and Tech	06200-5L9-A72RM	
AWD Advanced	06200-5L9-A81RM	
Cylinder Block Assembly	10002-5J2-A00	1
Cylinder Head Assembly (Front)	10004-R9P-A01	1
Cylinder Head Assembly (Rear)	10005-5J6-A00	1
Exhaust Pipe Gasket (NOK)	18212-SA7-003	2
Pre-Chamber Gasket	18393-SDB-A00	1
Self-Lock Nut (10 mm)	90212-SA5-003	9
Bolt (12 point 8 x 21 mm) (AWD Only)	90113-S10-000	8
Washer Bolt (10 x 30 mm) (AWD Only)	90382-SZA-003	2
Split Pin (3.0 x 22 mm)	94201-30220	2
Castle Nut (14 mm)	90363-S3V-A01	2
Spindle Nut (24 mm)	90305-SD4-003	2
Flange Nut (12 mm)	90371-SEF-000	4
Flange Bolt (10 x 35 mm)	90163-SDA-A01	1
Flange Bolt (10 x 45 mm)	90163-TZ3-A00	1
Flange Bolt (10 x 60 mm)	90168-TA1-A00	2
Flange Bolt (12 x 45 mm)	90165-SDA-A00	2
Flange Bolt (12x 45 mm)	90164-T2G-A01	1
Flange Bolt (10 x 30 mm)	90163-SDB-A00	3
Flange Bolt (12 x 56 mm)	90170-TZ3-A00	4
Flange Bolt (10 x 50 mm)	95701-10050-08	4
Intake Manifold Cover Gasket (Upper)	17112-5G0-A01	1
Intake Manifold Gasket (Nippon Leakless)	17105-R9P-A01	1
Throttle Body Gasket	16176-RYE-A10	1
Fuel Joint Pipe Set (MSDS includes VOC)	16012-R9P-305	1
Front Intake Manifold Base Gasket	17055-R9P-A01	1
Rear Intake Manifold Base Gasket	17065-R9P-A01	1
Injector Seal Set	16453-R9P-A00	2
O-Ring	91311-5A2-A01	1

Exhaust Chamber Gasket (Nippon Leakless)	18115-5G0-A01	2
EGR Pipe Gasket A	18716-R70-A01	1
EGR Pipe Gasket B	18719-R70-A01	1
Rear Cylinder Head Gasket (NIPPON LEAKLESS)	12261-R9P-A01	1
Front Cylinder Head Gasket (NIPPON LEAKLESS)	12251-R9P-A01	1
Timing Belt Idler Bolt	14551-RCA-A01	1
Front Water Passage Gasket (NIPPON LEAKLESS)	19411-5G0-A02	1
Rear Water Passage Gasket (NIPPON LEAKLESS)	19412-5G0-A01	1
O-Ring (Denso)	91307-RTA-005	2
Thermostat Cover Assembly	19315-5J2-A01	1
O-Ring (31.2 x 4.1 mm) (NOK)	91314-PH7-003	2
EGR Valve Gasket (ISHINO GASKET)	18715-PB2-000	1
Oil Filter	15400-PLM-A02	1
Radiator (DENSO)	19010-5J2-A01	1
Reserve Tank	19101-5J2-A00	1
Reserve Tank Cap	19102-5J6-A00	1
Reserve Tank Joint	19106-RSA-G00	1
Reserve Tank Tube A	19103-5J2-A00	1
Reserve Tank Tube B	19104-5J2-A00	1
Water Hose (Lower) (A)	19502-5J2-A50	1
Water Hose (Lower) (B)	19504-5J2-A50	1
Water Hose (Upper)	19501-5J2-A00	1
Water Inlet Hose	79721-TZ3-A00	1
Water Outlet Hose Assembly	79725-TZ3-A00	1
Warmer Hose B (ATF)	19433-5J2-A00	1
Water Hose B	19522-R9P-A00	1
Water Hose C	19523-5J2-A00	1
Water Hose A	19521-5J2-A00	1
Warmer Hose A (ATF)	19432-5J2-A50	1
Connecting Pipe	19505-5J2-A00	1
Water Passage	19410-5J2-A00	1
Flange Bolt (12 x 70 mm)	90051-R97-000	1
Flange Bolt (12 x 120 mm)	90051-5J4-000	1
Flange Bolt (10 x 30 mm)	90161-T2F-A01	3
Flange Bolt (10 x 45 mm)	90163-SZ3-000	3

Flange Bolt (14 x 135 mm)	90176-SDA-A00	2
Flange Bolt (10 x 77 mm)	90167-TZ7-A01	2
Flange Bolt (10 x 24 mm)	90166-TZ7-A01	2
Flange Bolt (14 x 150 mm)	90177-SDA-A00	2
Bolt Washer (8 x 16 mm)	90101-SWA-A00	2
Flange Bolt (12 x 33 mm)	90186-SDA-A00	2
Flange Bolt (10 x 34 mm)	90162-T2A-A00	4
Snap Ring (32 x 2.2 mm)	44319-STX-A01	1
Set Ring (32 x 2.2 mm)	44319-STX-A60	1
Spindle Nut	90305-S3V-A11	2
Injector Clip	16451-5A2-A01	6
Sealing Washer (12 mm)	16705-5A2-A01	2

REQUIRED MATERIALS – REPAIR PROCEDURE D-

Part Name	Part Number	Quantity
Coolant Type 2	OL999-9011A	3
Acura motor oil 0W-20	08798-9073	6

TOOL INFORMATION

Part Name	Part Number	Quantity
Coolant Flush Kit Pump and Filter Set	VSB02C000045	1
9 A/T Pressure Test Kit	VSB02C000046	1
9 A/T Bucket and Hose Set	VSB02C000047	1
9 A/T Adapter and Hardware Set	VSB02C000048	1

NOTE:

- Each dealer was sent one of each of these tools. If you need additional tools, contact the Honda Tool and Equipment Program at 888-424-6857.
- Individual items in the kit and sets are not available separately. You must order the complete kit or set.

Coolant Flush Kit Pump and Filter Set - VSB02C000045



9 A/T Adapter and Hardware Set - VSB02C000048



9 A/T Pressure Test Kit - VSB02C000046



9 A/T Bucket and Hose Set - VSB02C000047



DATE INSPECTION

1. Inspect the date on the transmission warmer. The affected transmission warmers were built between April 28, 2015 (2015-04-28) and July 15, 2015 (2015-07-15).
 - If the build date **is within the date range**, go to ATF WARMER INSPECTION.
 - If the build date is before or after the date range, go to step 2.

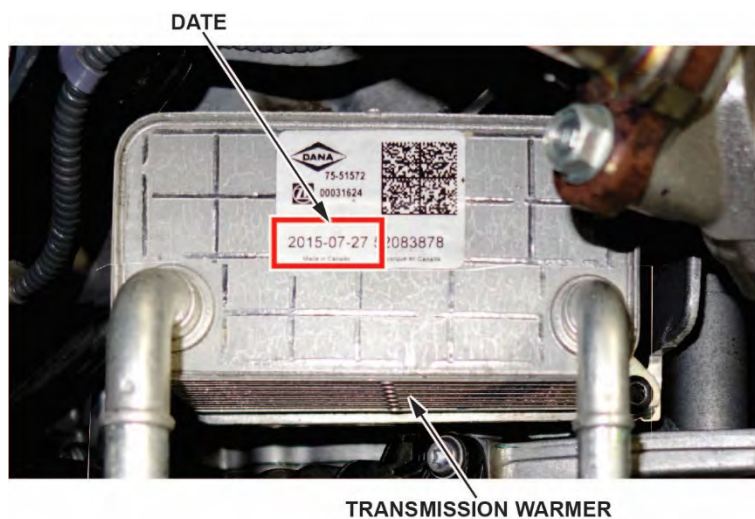

2. Check the client responses on the RO to see if the vehicle overheated.
 - If the vehicle did not overheat, go to [REPAIR PROCEDURE A](#).
 - If the vehicle did overheat, go to [REPAIR PROCEDURE B](#).

ATF WARMER INSPECTION

1. Raise the vehicle on a lift.
2. Remove the splash shield. Refer to the service information.
3. Remove the air cleaner. Refer to the service information.
4. Remove the intake air guide. Refer to the service information.
5. Remove the 12-volt battery. Refer to the service information.
6. Remove the battery box. Refer to the service information.
7. Remove the connector bracket. Refer to the service information.
8. Using commercially-available clamps, pinch off the coolant hoses.

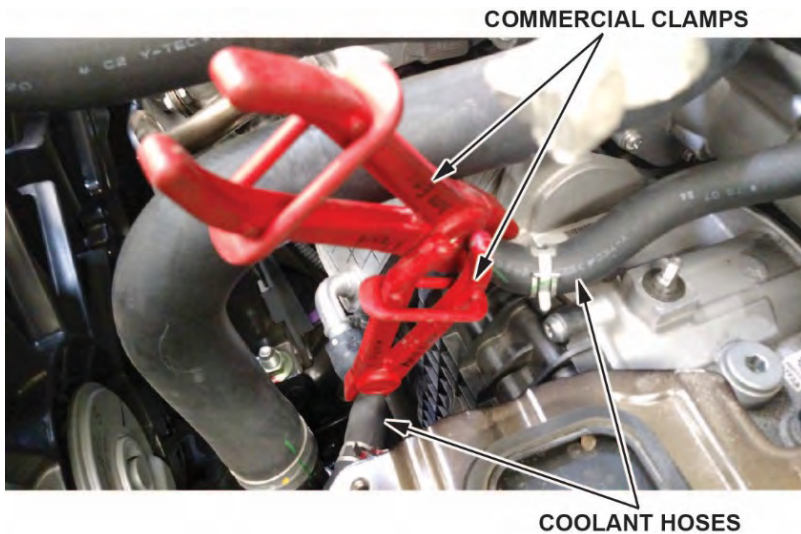

9. Remove the coolant hoses from the transmission warmer.

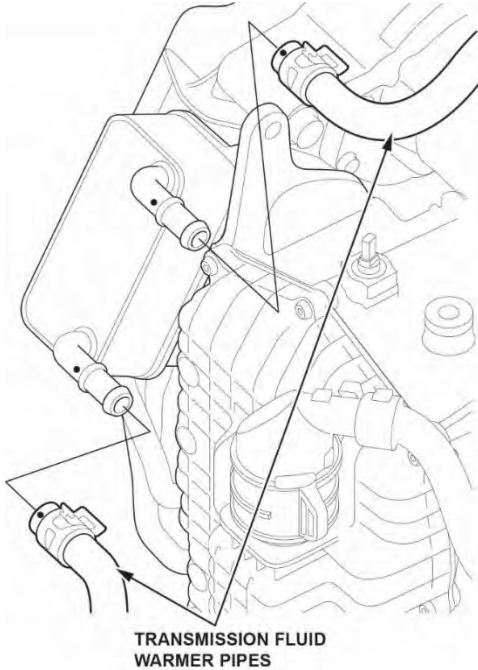

10. Clean the connection points around the transmission fluid warmer pipes.

11. Remove the 3 hold down bolts and 2 fixing plate bolts to remove the transmission warmer. Place the warmer on a clean surface.

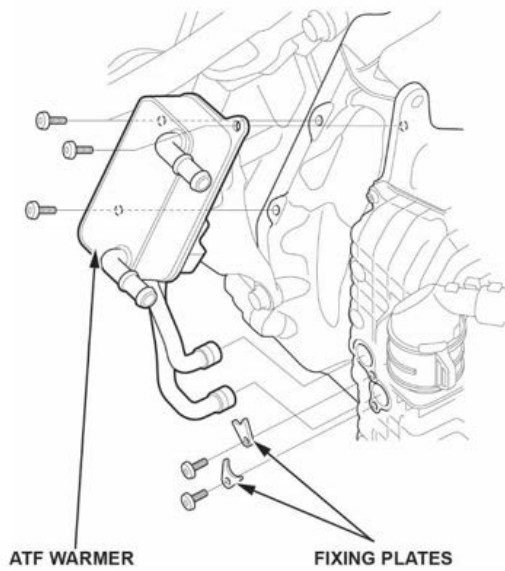

12. Prepare the transmission warmer to check for leaks.

- Remove the original ATF lines from the warmer.
NOTE: Be careful not to damage the lines as you may reuse them.
- Install the pressure check tool as shown with the fixing plates, and torque the bolts to **10 N-m (7 lb-ft)**.
- Fill a bucket with warm water.
- Connect shop air to pressurize the warmer, and adjust the pressure check tool to **70 psi**.

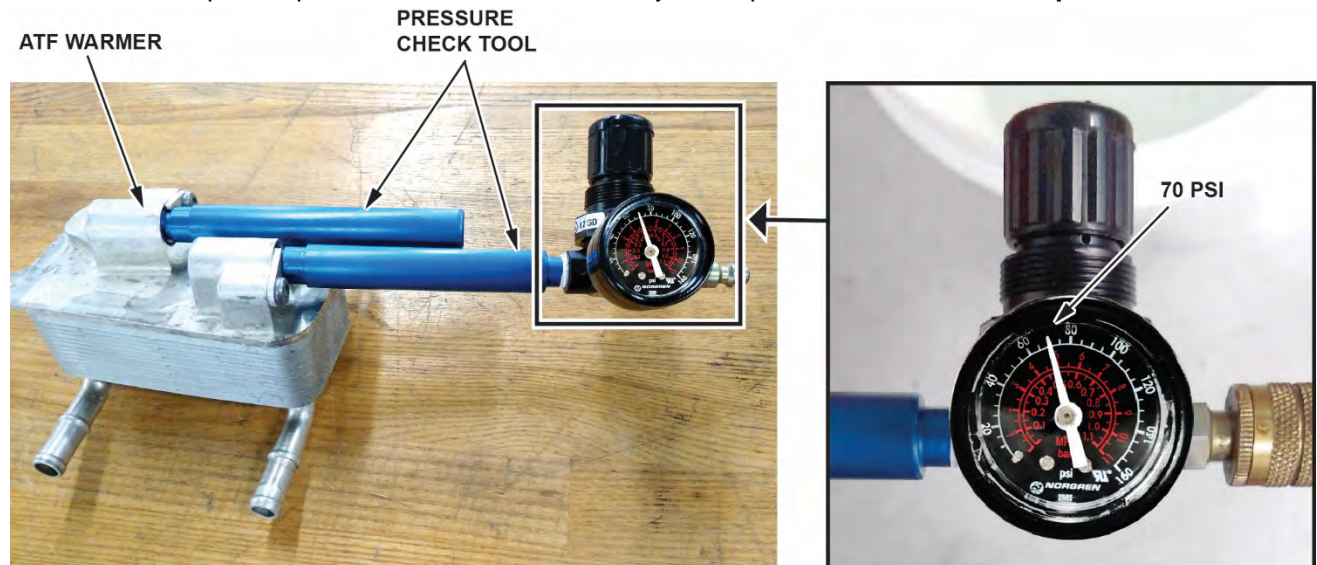

13. Check the transmission warmer for leaks by submerging the warmer completely under the water and watching for bubbles.

NOTE: Some bubbles are normal when the transmission warmer is first submerged and will come to a stop. If there is a leak, there will be a steady stream of bubbles coming from the transmission warmer.

- If there are no bubbles coming from the warmer, continue with the warmer replacement. Go to step 14.
- If there are bubbles, take photos (see Photos) and check to see if the vehicle also overheated by checking the customer responses on the RO.
 - If the transmission warmer leaks but the engine did not overheat, go to [REPAIR PROCEDURE C](#).
 - If the transmission warmer leaks and the engine overheated, go to [REPAIR PROCEDURE D](#).



Photos

If there are bubbles because of a leaking transmission warmer, take photos of the bubbles during the pressure test, the transmission warmer serial number, and the VIN.

- The pressure test

ATF WARMER PRESSURE TEST



Take this photo:

BUBBLES

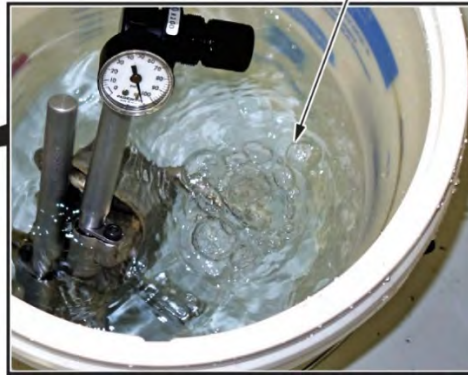

- The transmission warmer serial number

TRANSMISSION WARMER



Take this photo:



- VIN

VIN LABEL



Take this photo:



NOTE:

- These photos must be submitted with any warranty claim where the transmission is replaced.
- Make sure you install the leaking transmission warmer on the original transmission to be returned to the remanufacturing facility. Any transmission replacement claims that do not have the leaking warmer installed on the returned transmission may be subject to debit.
- **Any transmission replacement claims that do not include the required photos may be subject to debit.**

Unacceptable Photos

Photos must correspond to the warranty claim submittal standards. Photos may be rejected for the following reasons:

- Out of focus and unreadable
- Too small of a file size
- Too dark

14. Remove the 8 O-rings on the pipes by gently pushing the O-rings off with your fingers.

NOTE:

- Do not use picks or screwdrivers to remove the O-rings as you may damage the sealing surface.

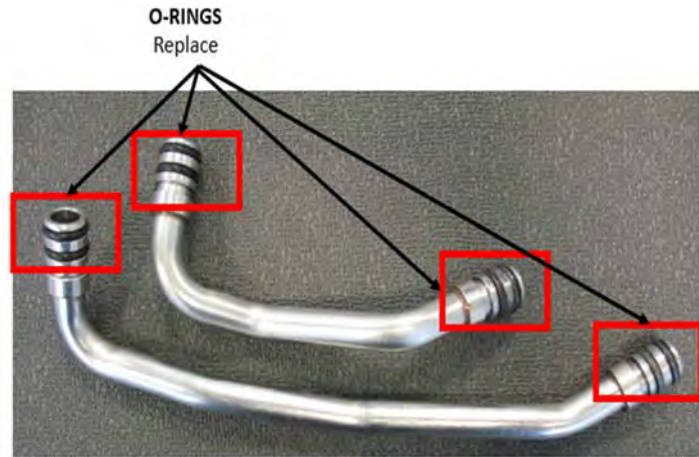

15. Clean the pipes, then install four new O-rings.

NOTE: Make sure your hands or gloves are clean to avoid contaminating the O-rings.

16. Coat the O-rings with ATF 3.1.

17. Install the original ATF warmer pipes onto the new transmission warmer using the fixing plates. Torque the bolts to **10 N·m (7 lb-ft)**.

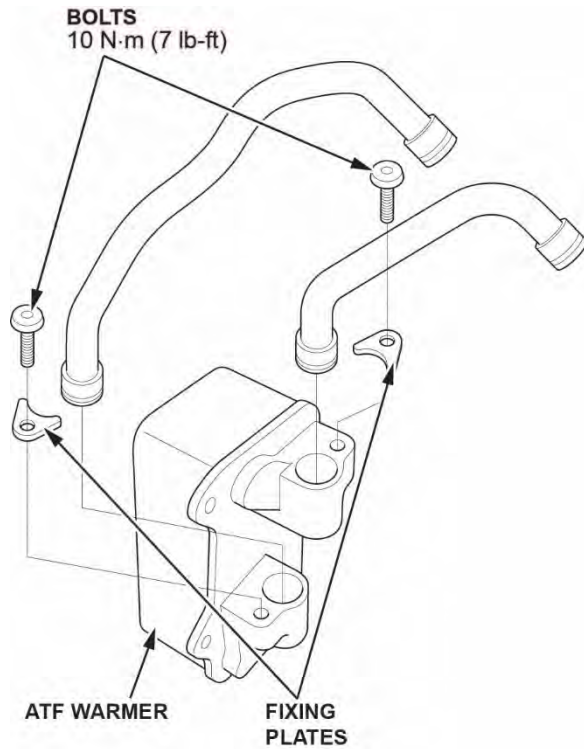

18. Install the new transmission warmer to the transmission. Install the ATF warmer pipes using fixing plates. Torque the bolts to **10 N·m (7 lb-ft)**.

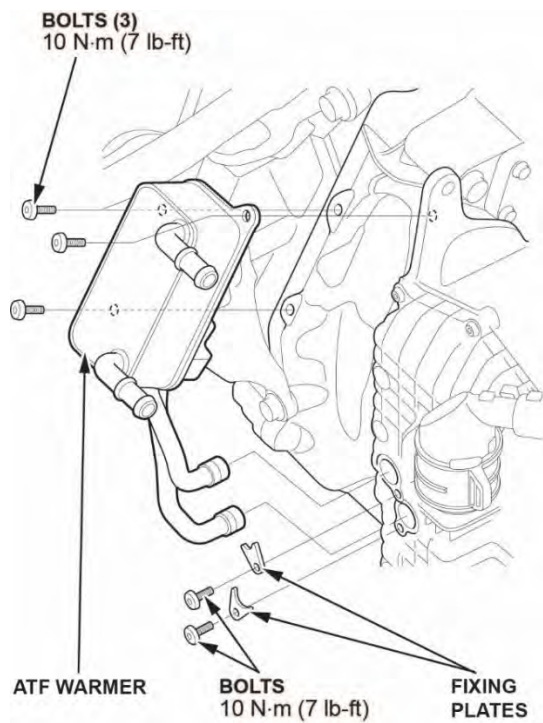

19. Check to see if the vehicle also overheated by checking the customer responses on the RO.

- If the engine **did not overheat**, go to step 20.
- If the engine overheated, go to [REPAIR PROCEDURE B](#).

20. Install the connector bracket.

21. Go to [REPAIR PROCEDURE A](#).

REPAIR PROCEDURE A

NOTE:

- Use this procedure only if the engine did not overheat. If the engine overheated, go to REPAIR PROCEDURE B.
 - Fill in the flush work sheet (see page 58), and attach it to the RO.
1. Disconnect the upper and lower radiator hoses at the engine.

DISCONNECT:

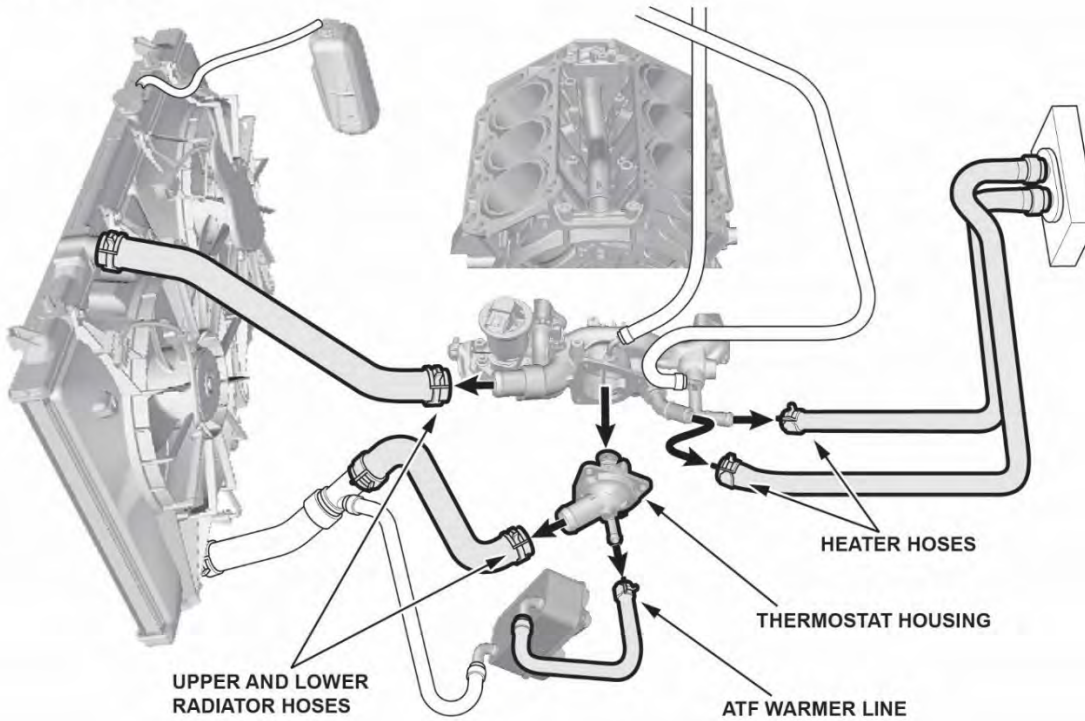

2. Disconnect the two heater hoses at the engine.
3. Disconnect the ATF transmission warmer line (coolant).
4. Remove the thermostat housing.

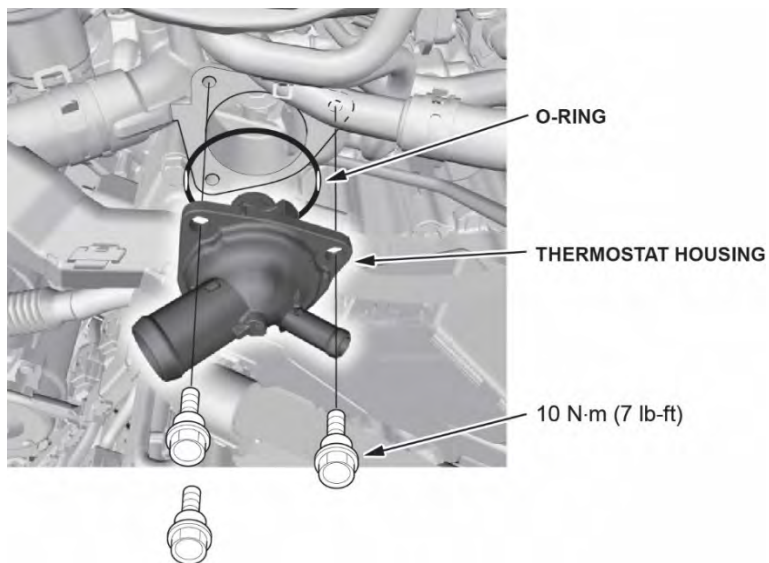

5. Remove the thermostat from the housing using a 32 mm socket. Push in on the thermostat, and twist the socket. Once the thermostat has released from the housing, remove the thermostat.

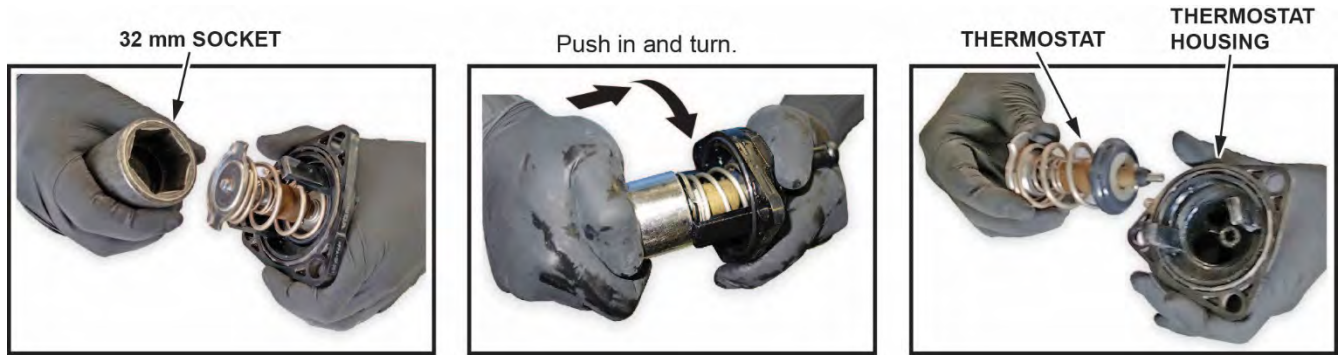

6. Install the green rubber plug from the coolant flush kit into the thermostat water jacket as shown. To prevent the plug from falling into the water passage, cover the opening with a shop towel.

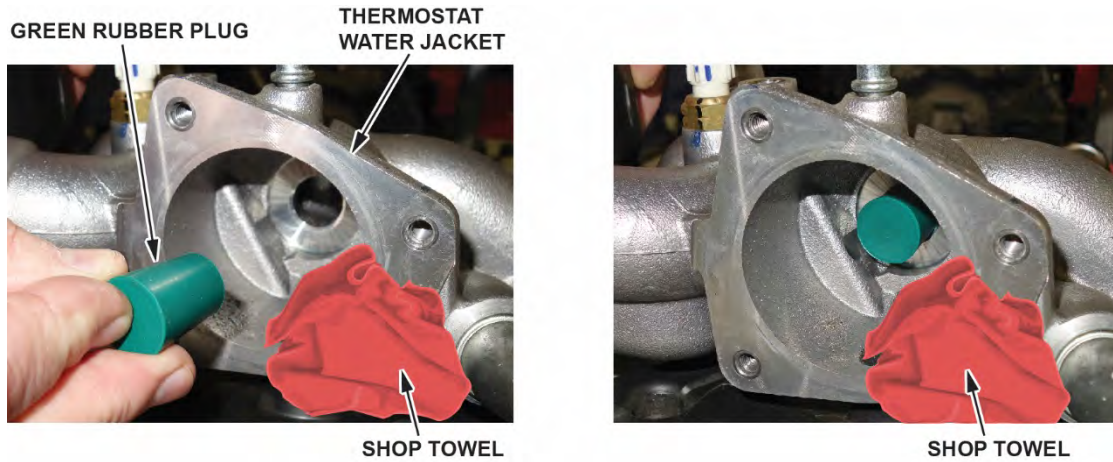

7. Remove the shop towel, and install the thermostat housing without the thermostat.

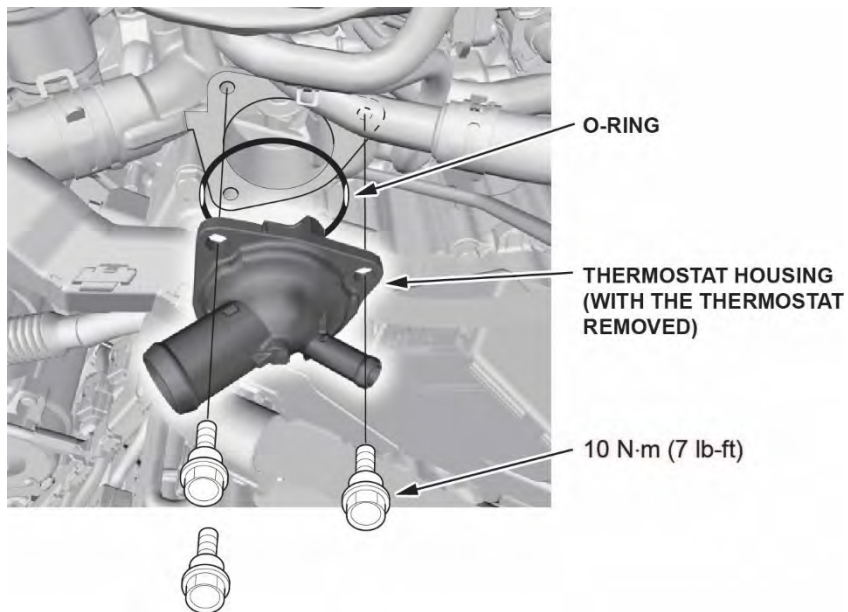

8. Using the three colored plugs from the flush kit, cap off both heater hoses and the ATF transmission warmer line as shown.



ATF TRANSMISSION
WARMER LINE

HEATER HOSES

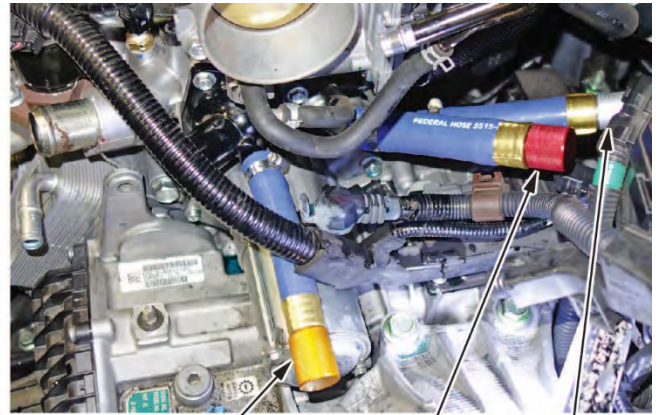

YELLOW PLUG
(ATF WARMER LINE)

RED PLUG
(HEATER
HOSE)

SILVER PLUG
(HEATER
HOSE)

9. Using commercially available clamps, clamp the throttle body coolant lines as shown.

Clamp both of the throttle body coolant lines.



10. Remove the lid from the SUPPLY bucket, and install the large (1.5 in.) return hose with the T-fitting through the hole in the lid as shown.



ENGINE RETURN HOSE

T-FITTING

SUPPLY BUCKET

11. Install the thermostat adaptor to the pump outlet hose.

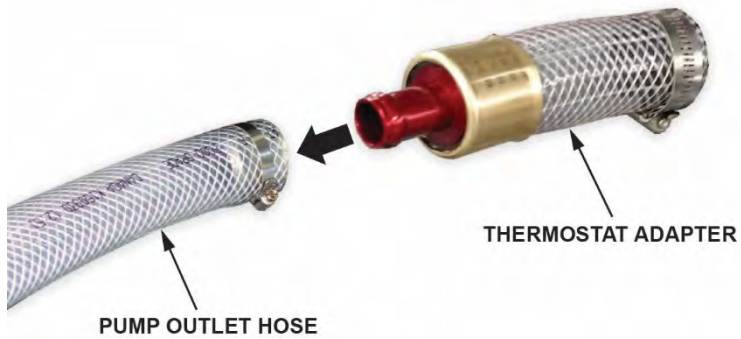

PUMP OUTLET HOSE

THERMOSTAT ADAPTER

12. Install the pump outlet hose onto the thermostat housing.



PUMP
OUTLET
HOSE
ASSEMBLY

13. Install the return hose onto the water passage as shown.

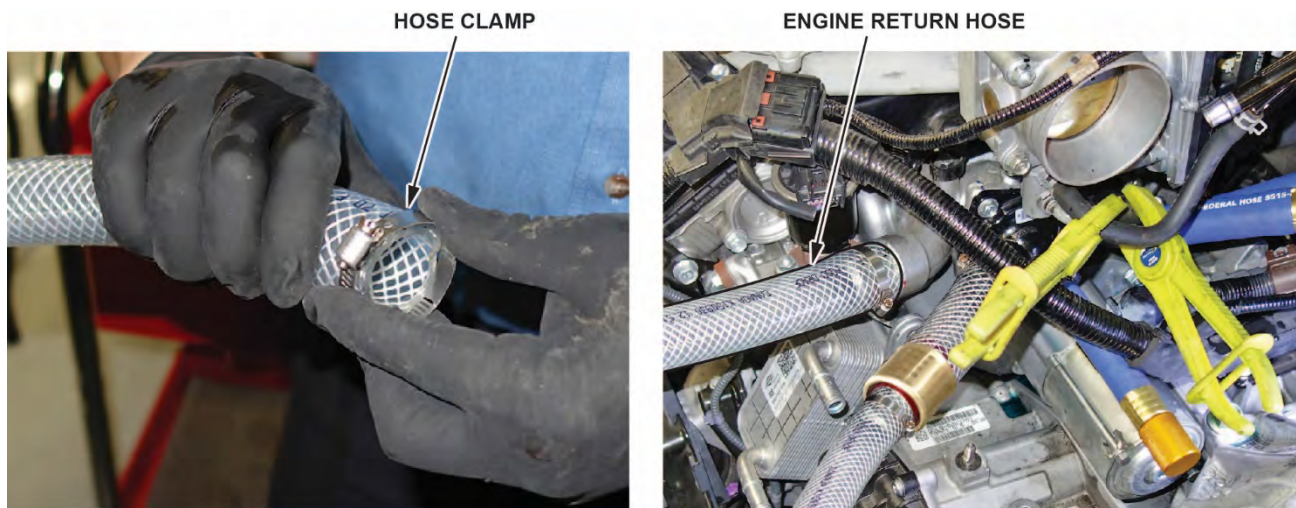

14. Fill the SUPPLY bucket with 4.5 gallons of fresh water and install the lid to the bottom of the upper lip.

15. Install the pump inlet line to the SUPPLY bucket lid as shown.

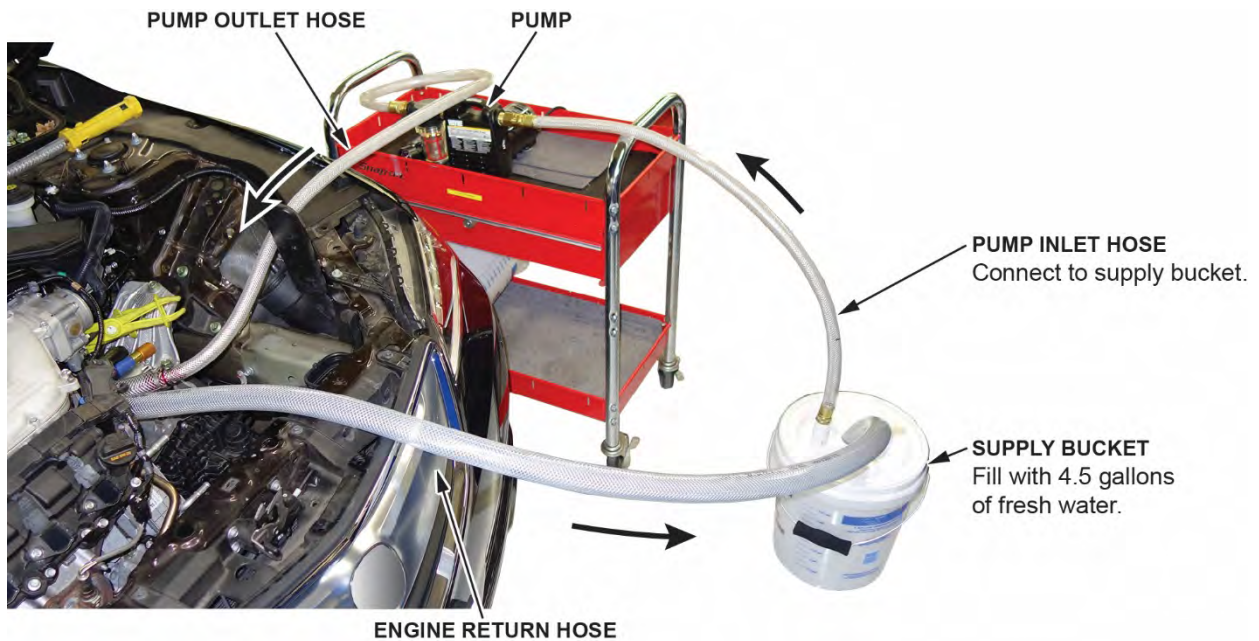

16. Turn on the pump, and let it run for 10 minutes.

NOTE: If this is the first time using the pump, remove the priming plug, fill the pump with clean water, then reinstall the plug.



17. After 10 minutes, turn the pump off and dump all the contents of the SUPPLY bucket into the waste coolant container. Wipe off any oil residue from the bucket, refill the bucket with water, repeat the flush 4 more times (50 minutes total time flushing with water), then go to step 18.

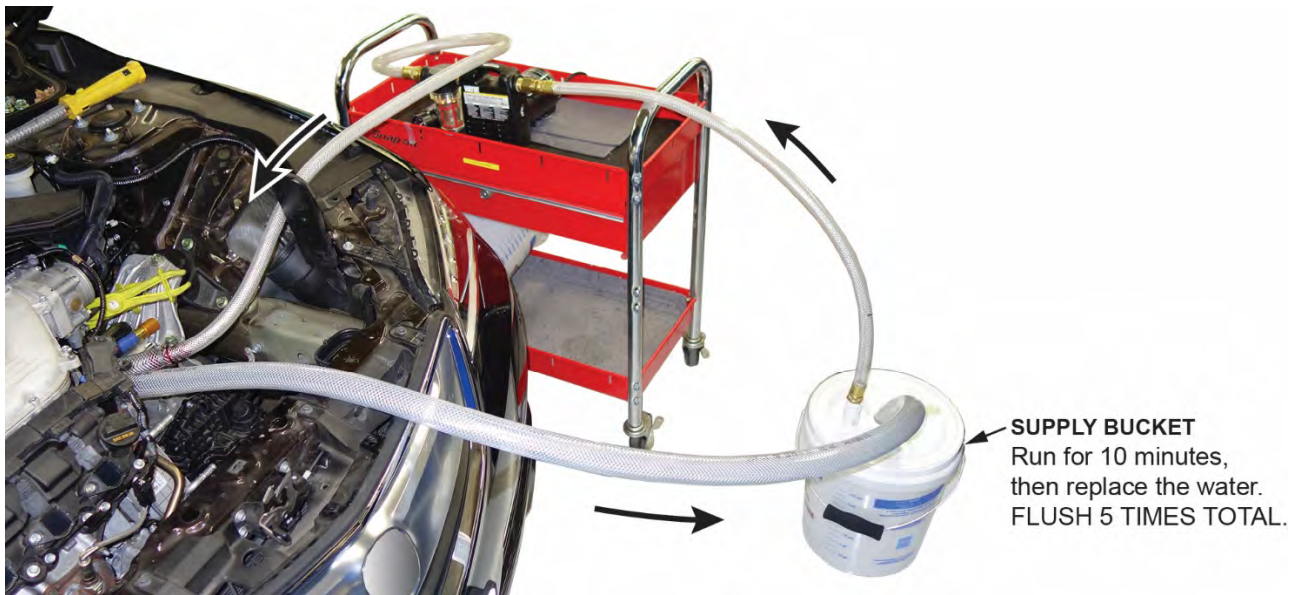

18. Substitute the water for coolant (OL999-9011A), and run the pump for 10 minutes to circulate the fluid.

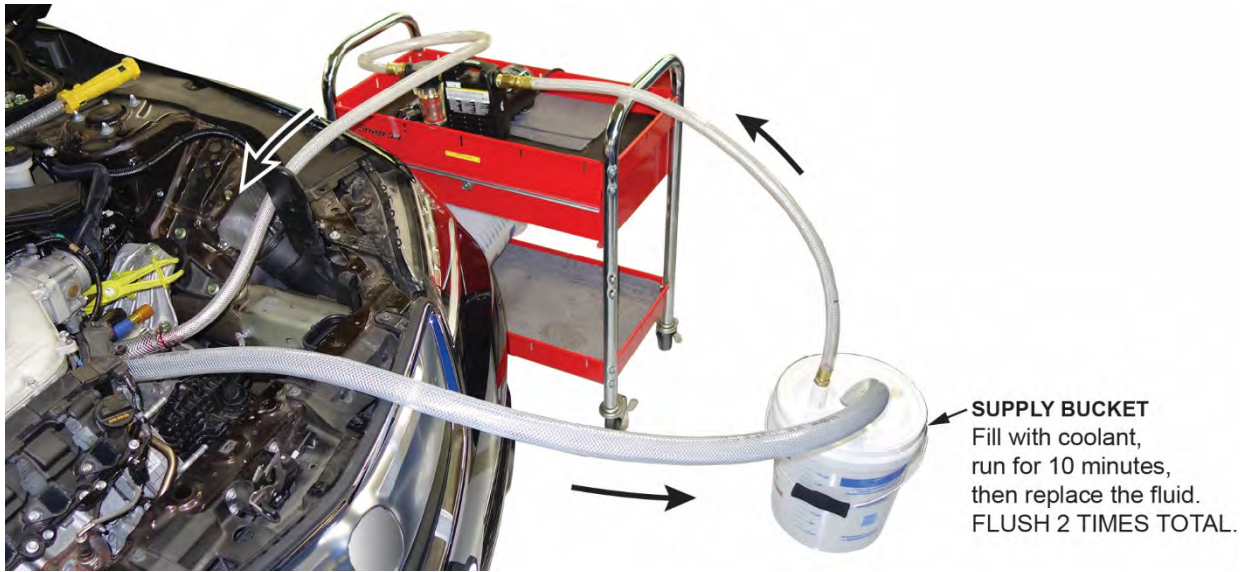

19. After 10 minutes, turn the pump off and dump all the contents of the SUPPLY bucket into the waste coolant container. Refill the SUPPLY bucket with coolant, and run the pump for 10 minutes.

20. Disconnect the pump outlet line from the engine, and remove the thermostat adaptor. Replace the outlet adaptor with the 0.75 in. heater hose adaptor.

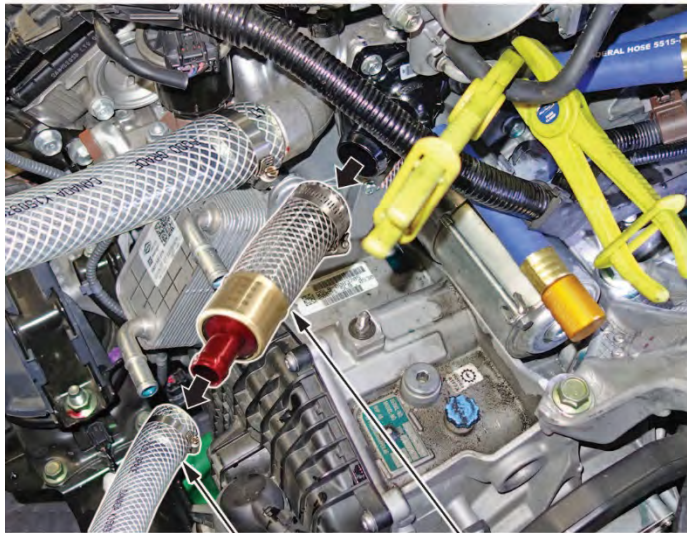

PUMP OUTLET HOSE
Disconnect.

THERMOSTAT ADAPTER

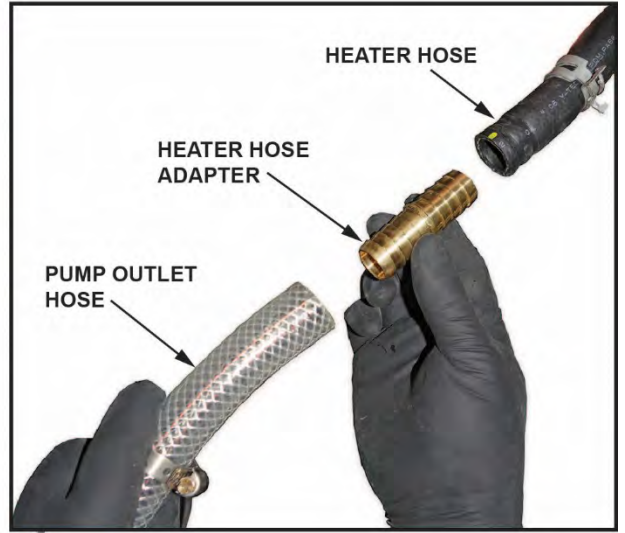

HEATER HOSE

HEATER HOSE ADAPTER

PUMP OUTLET HOSE

21. Remove the thermostat cover, remove the green rubber plug, and return it to the coolant flush kit. To prevent the plug from falling into the water passage, cover the passage with a shop towel.

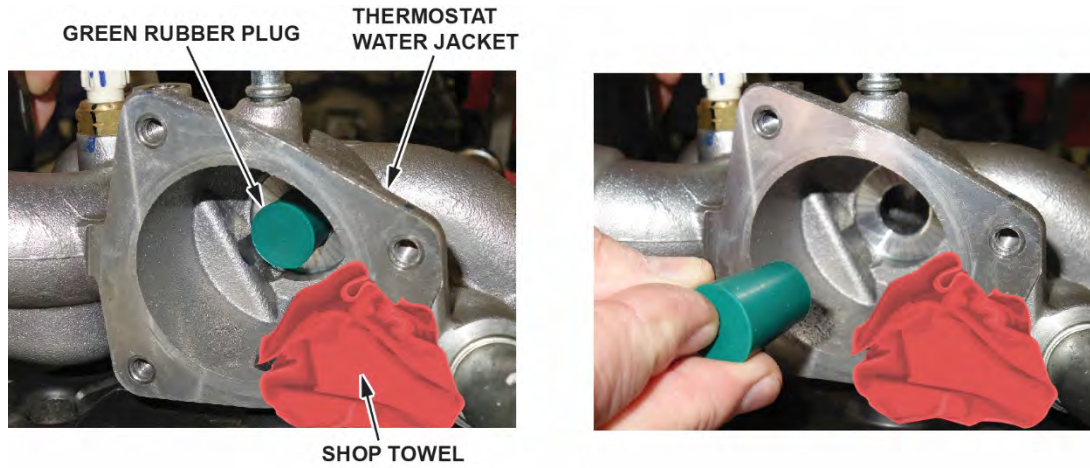

22. Connect the pump outlet hose to the heater hose as shown.



23. Install the heater core return hose through the DUMP bucket lid.



HEATER CORE RETURN HOSE

T-FITTING

DUMP BUCKET

24. Attach the heater core return hose to the heater hose as shown.

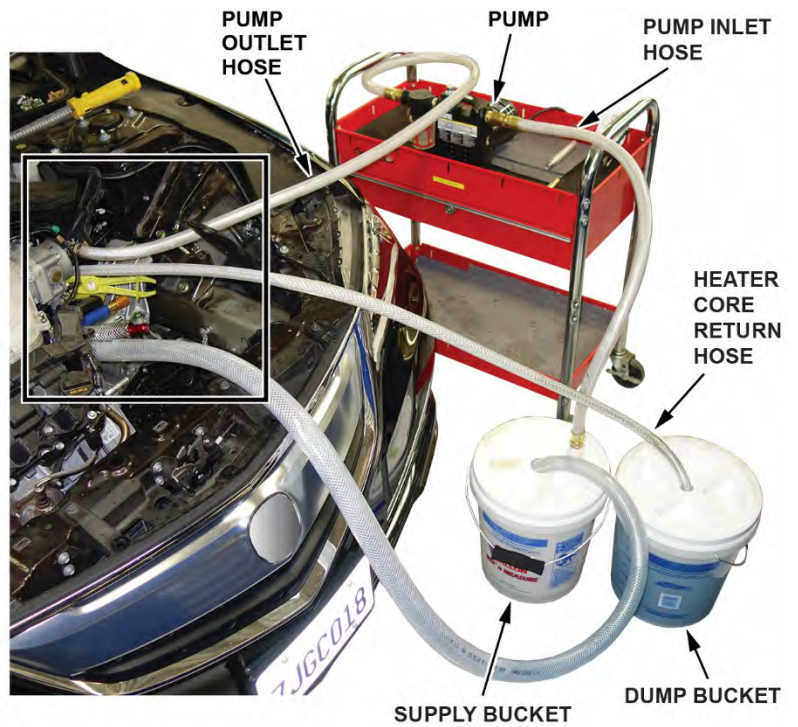
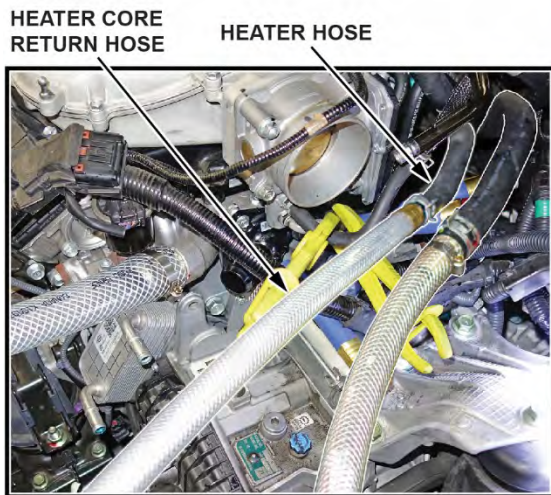

PUMP OUTLET HOSE

PUMP

PUMP INLET HOSE

HEATER CORE RETURN HOSE

HEATER HOSE

HEATER CORE RETURN HOSE

SUPPLY BUCKET

DUMP BUCKET

25. Fill the SUPPLY bucket with water and run the pump until the SUPPLY bucket is empty.

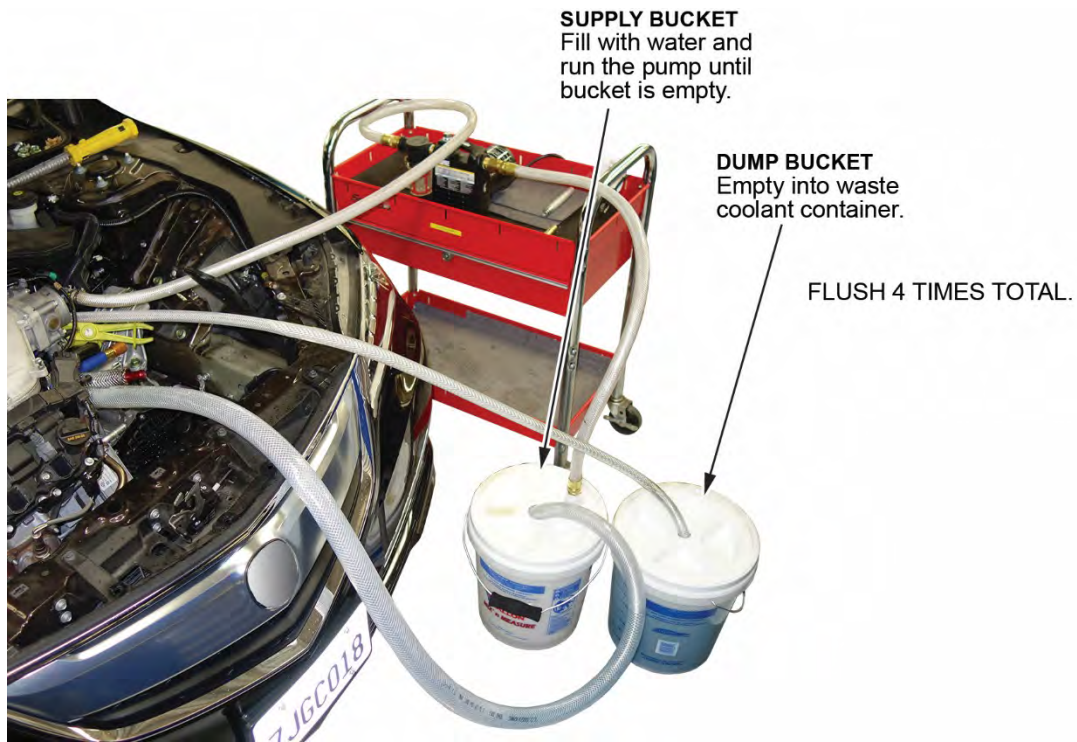

26. Empty the DUMP bucket into the waste coolant container.

27. Repeat the flush (steps 25 and 26) 3 more times.

28. Empty the DUMP bucket into the waste coolant container, and wipe off any oil residue from the bucket.

29. Remove the pump and return hoses, clamps from the throttle body hoses and the three colored plugs from the vehicle.

30. Replace the radiator, the 10 indicated coolant hoses, thermostat, coolant reserve tank and hoses, and the 2 ECT sensor (1 and 2) O-rings. Refer to the image for the location of all the components.

NOTE:

- **Make sure to remove the green rubber plug that was installed in the thermostat water jacket and return it to the flush kit.**
- **When refilling the cooling system after the flush is complete, some oil may be present in the cooling system. Thorough testing has shown the amount left over after the flush procedure is within acceptable limits provided the flush procedure was followed completely.**

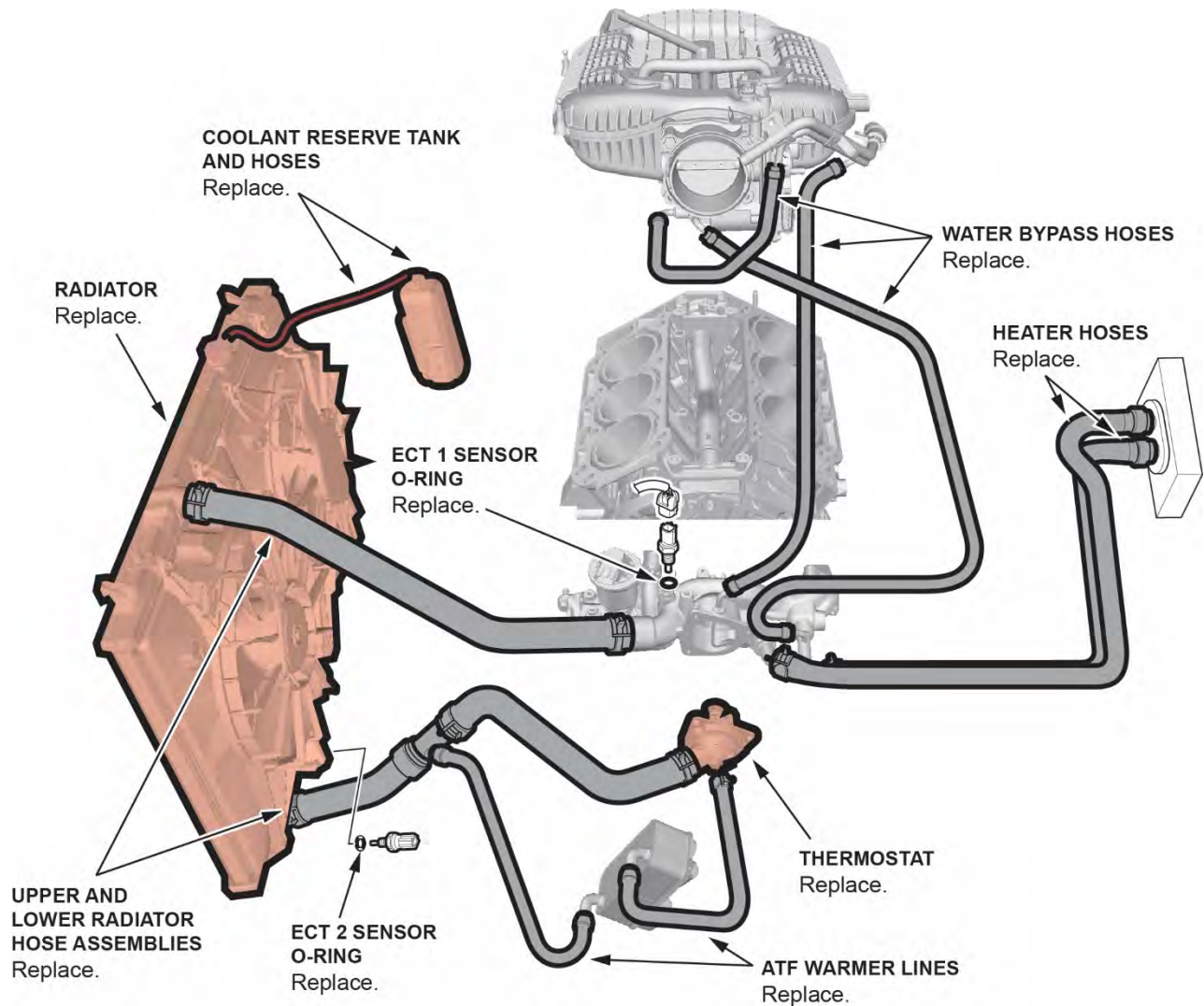

31. Fill the engine with coolant.
32. Install the battery box and the 12-volt battery.
33. Install the air guide and the air cleaner.
34. Fill the engine with coolant.
35. If the transmission warmer was replaced, check the ATF and adjust as needed. Refer to the service information.
- NOTE: Make sure you use Honda ATF Type 3.1 if you have to add fluid. Using the wrong ATF can affect shift quality.
36. Check for any ATF and coolant leaks.
37. Reinstall the splash shield.

REPAIR PROCEDURE B

NOTE:

- Use this procedure only if the engine overheated. If the engine did not overheat, go to REPAIR PROCEDURE A.
 - Fill in the heater core part of the flush work sheet (see page 58), and attach it to the RO.
1. Remove the engine and transmission assembly (only the engine will be replaced). Refer to the service information.

Heater Core Flush Procedure

2. Connect the pump to the SUPPLY bucket.

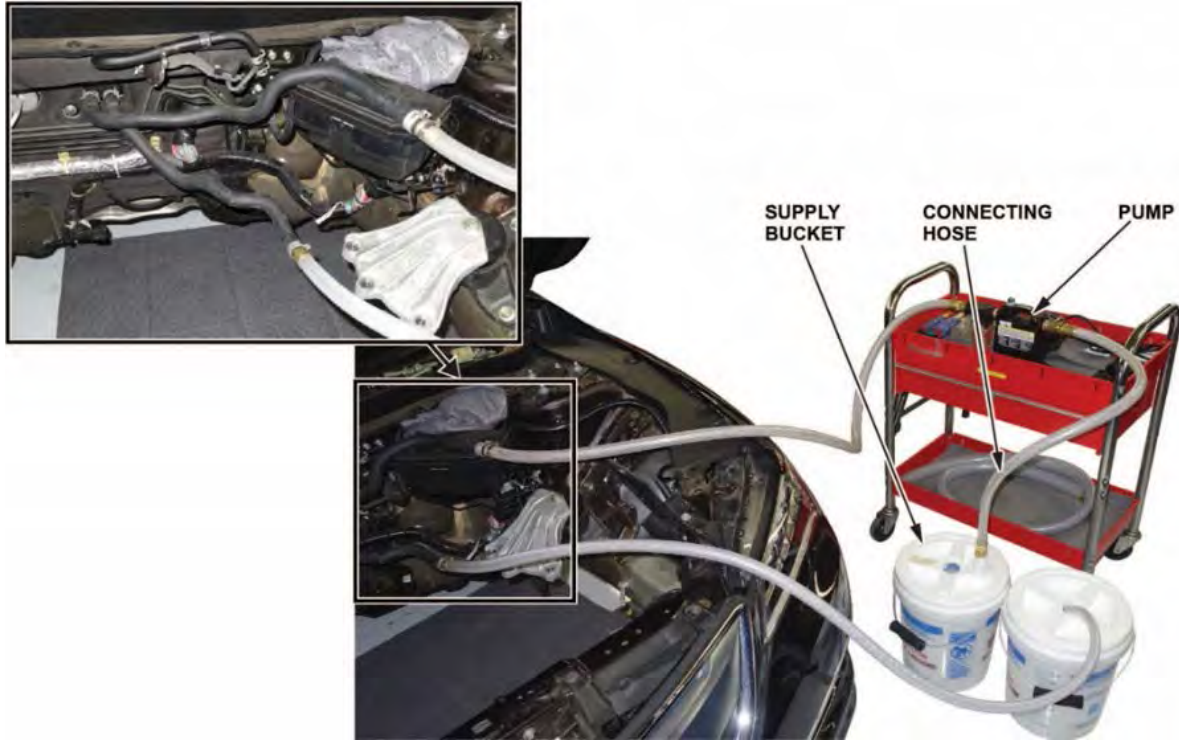

3. Make sure the 0.75 in. heater hose adaptor is installed on the pump outlet hose, then connect the pump outlet hose to the heater hose as shown.

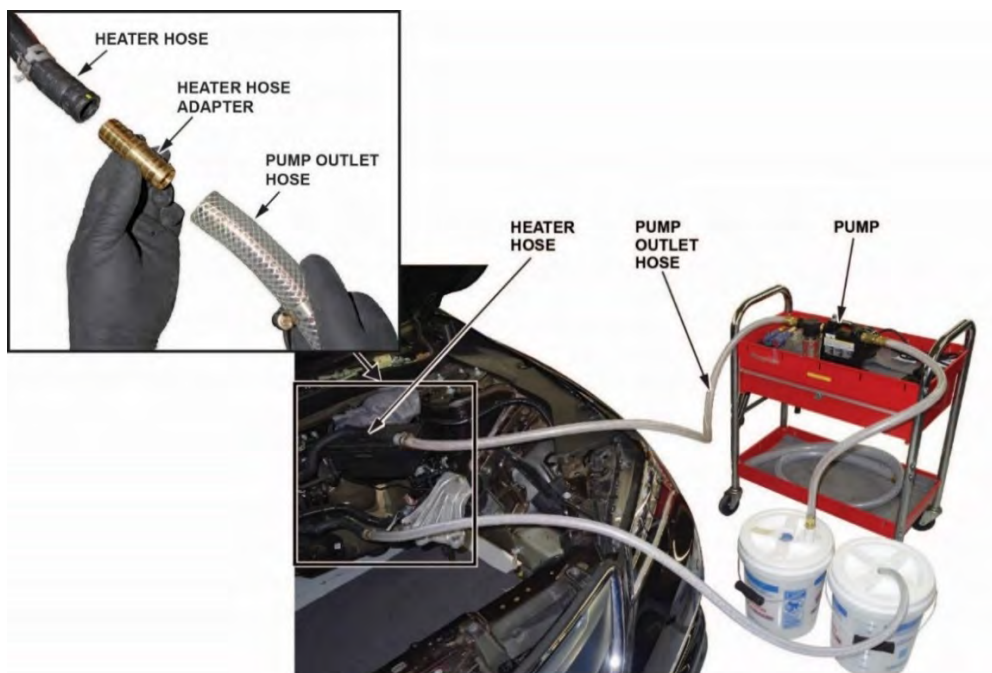

4. Install the return hose through the DUMP bucket lid, then install the lid on the bucket.

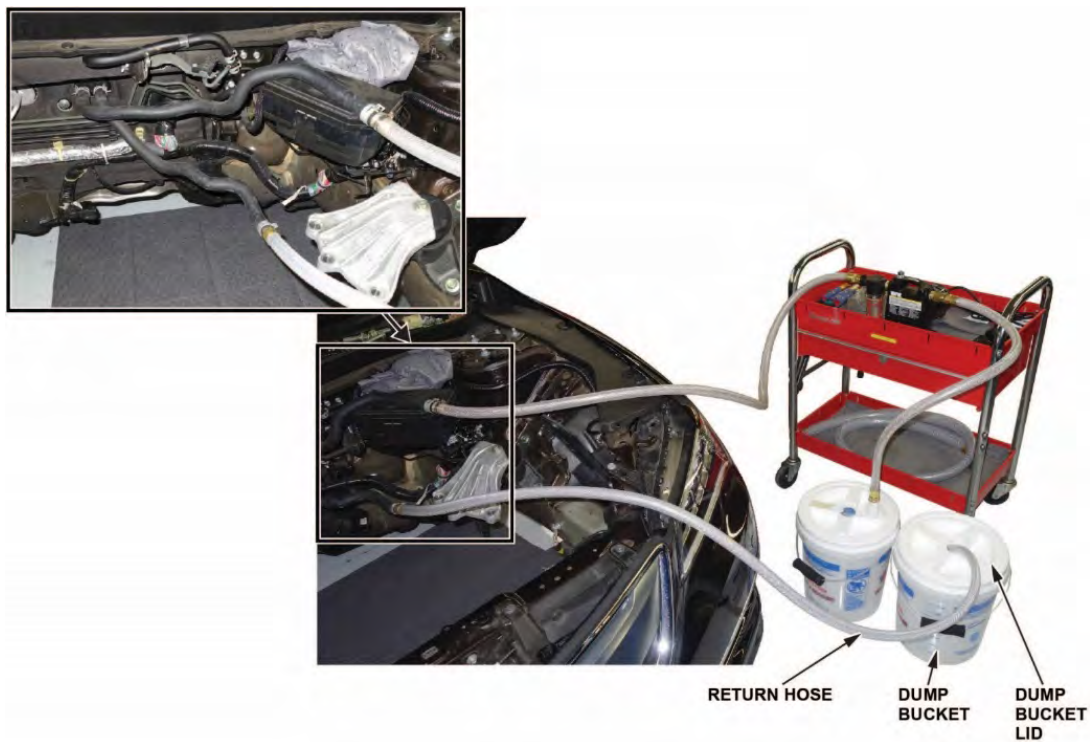

5. Attach the heater core return hose to the heater hose as shown.

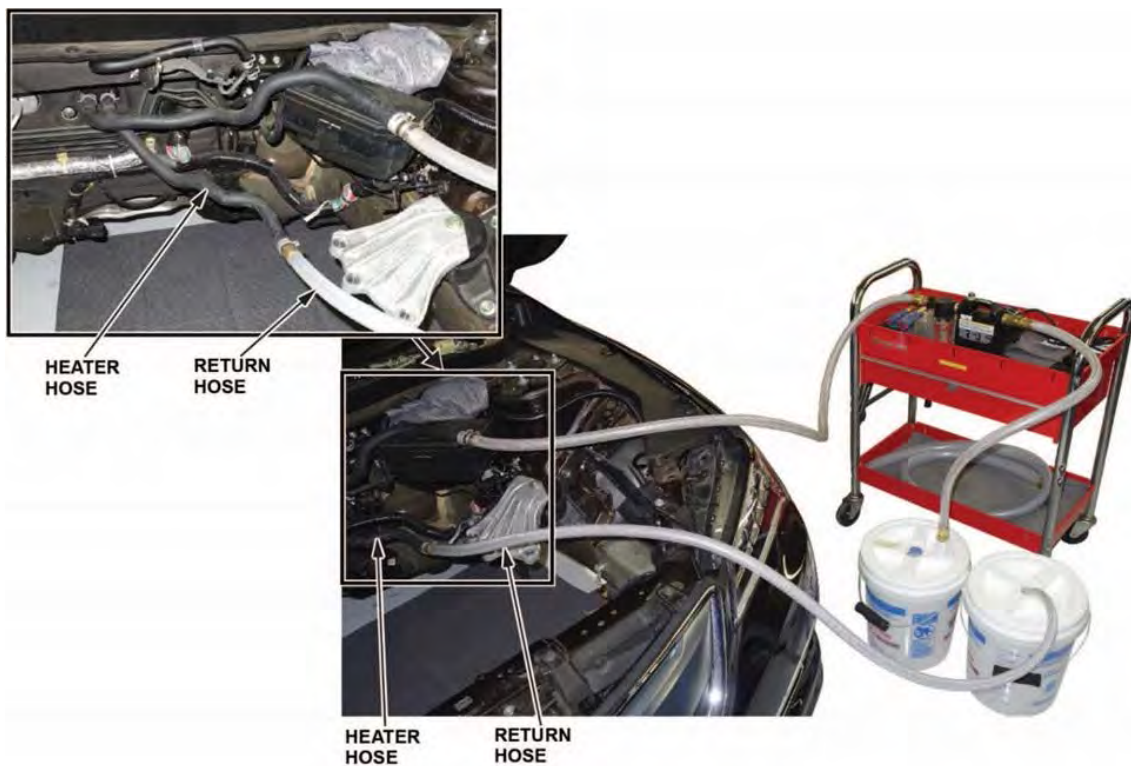

6. Fill the SUPPLY bucket with water, and run the pump until the SUPPLY bucket is empty.



SUPPLY BUCKET
Fill with water and
run the pump until
bucket is empty.

DUMP BUCKET
Empty into waste
coolant container.



FLUSH 4 TIMES TOTAL.

NOTE: If this is the first time using the pump, remove the priming plug, and fill the pump with clean water, then reinstall the plug.

PRIMING PLUG



CLEAN WATER



7. Empty the DUMP bucket into the waste coolant container.
8. Repeat the flush 3 more times.
9. Empty the DUMP bucket into the waste coolant container, and wipe off any oil residue from the bucket.
10. Remove the pump and return hose from the vehicle.

Reassemble Vehicle

11. Install a new short block and new cylinder heads including the water pipe and water passage.
12. Replace the radiator, the 10 indicated coolant hoses, the thermostat, the water passage and water connecting pipe, the coolant reserve tank, the 2 ECT sensor (1 and 2) O-Rings, and the coolant reserve tank and hoses. Refer to the image for the location of all the components.

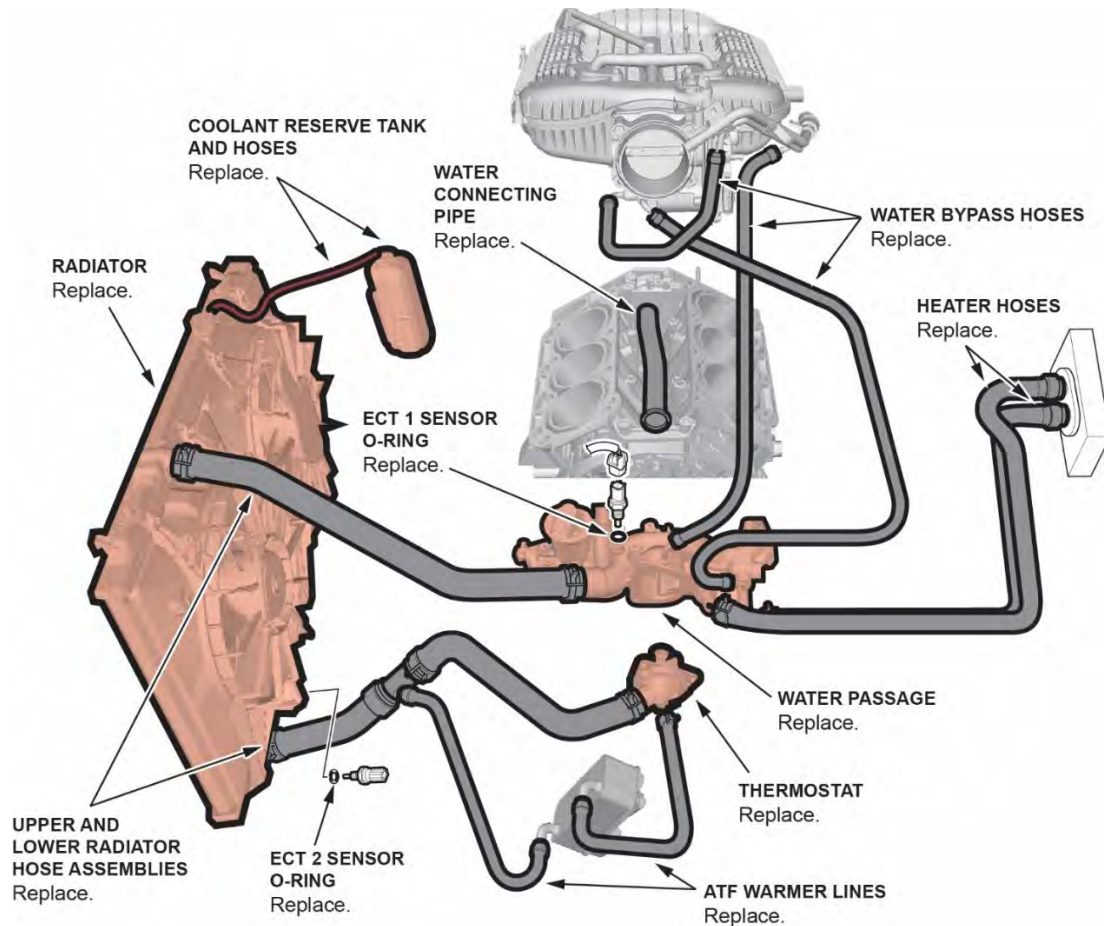

13. Do the PCM idle learn, and CKP-pattern learn. Refer to service information.

REPAIR PROCEDURE C

NOTE:

- Use this procedure only if the transmission warmer failed the pressure test and the engine did not overheat. If the engine overheated, go to REPAIR PROCEDURE D.
 - Fill in the flush work sheet (see page 58), and attach it to the RO.
1. Remove the transmission.

Engine and Heater Core Flush Procedure

2. Disconnect the upper and lower radiator hoses at the engine.

DISCONNECT:

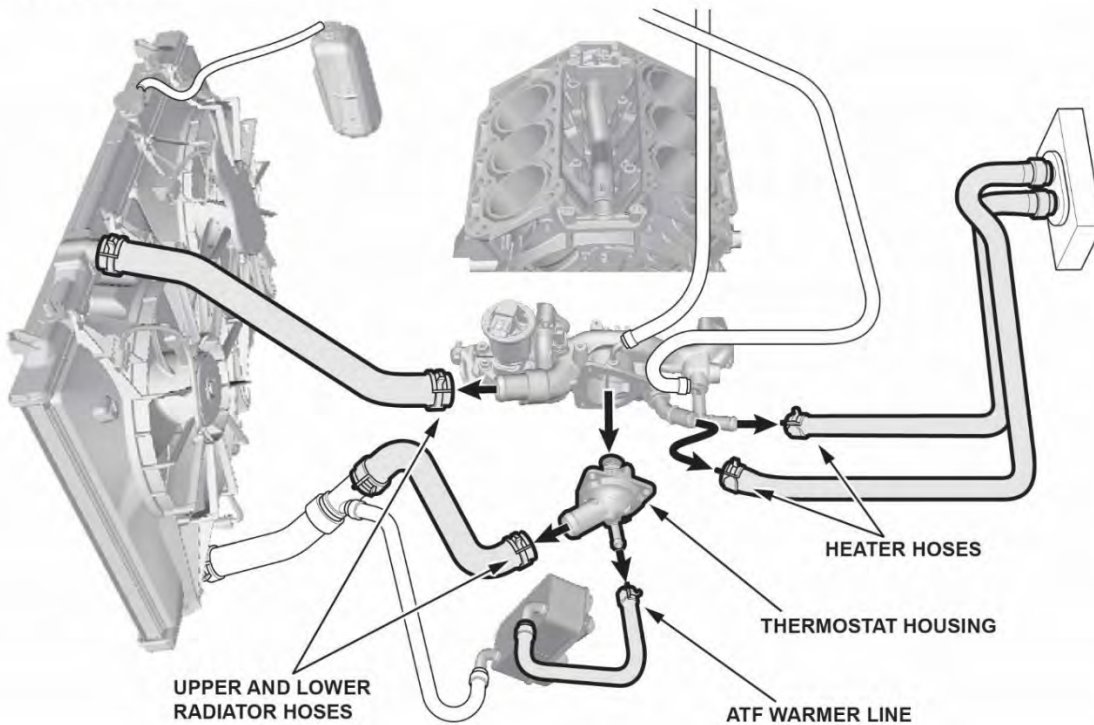

3. Disconnect the two heater hoses at the engine.
4. Disconnect the ATF warmer line (coolant).
5. Remove the thermostat housing.

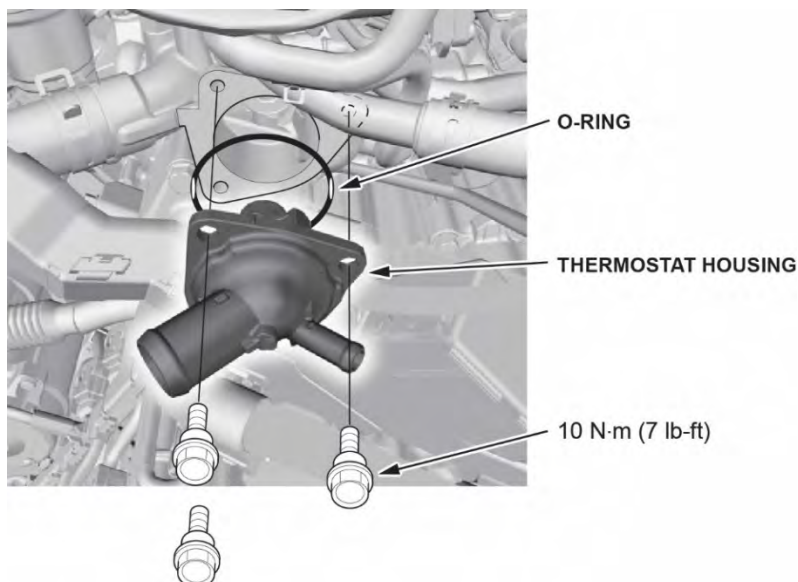

6. Remove the thermostat from the housing using a 32 mm socket. Push in on the thermostat, and twist the socket. Once the thermostat has released from the housing, remove the thermostat.

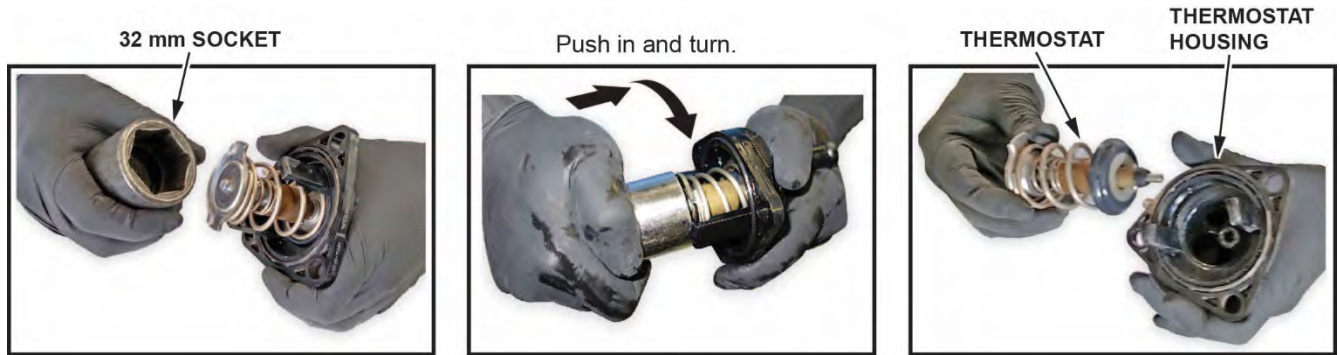

7. Install the green rubber plug from the coolant flush kit into the thermostat water jacket as shown. To prevent the plug from falling into the water passage, cover the opening with a shop towel.

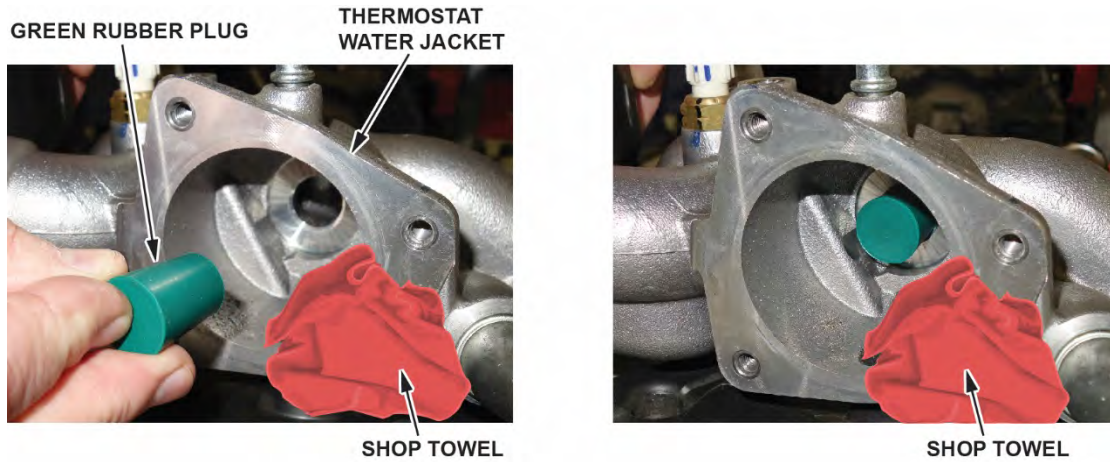

8. Remove the shop towel, and reinstall the thermostat housing without the thermostat.

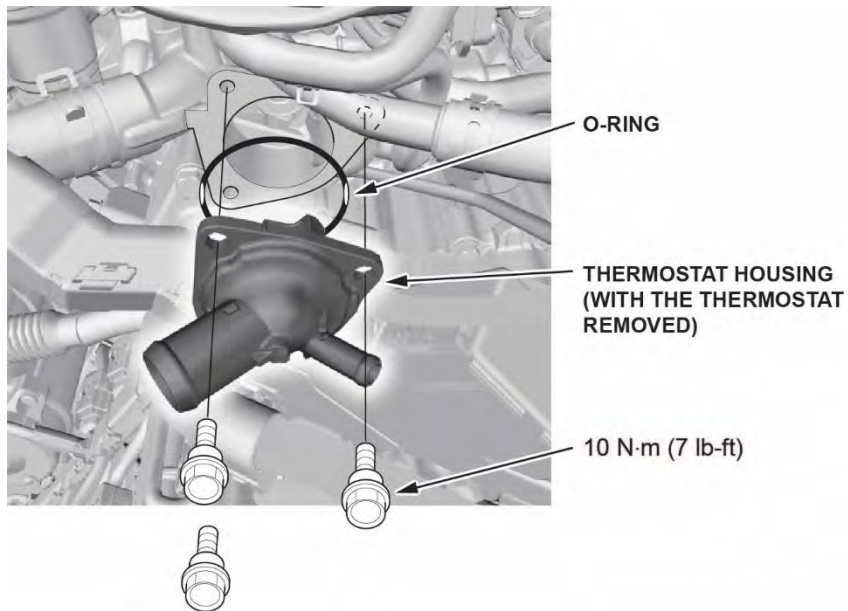

9. Using the three colored plugs from the flush kit, cap off both heater hoses and the ATF transmission warmer line as shown.



ATF TRANSMISSION
WARMER LINE

HEATER HOSES

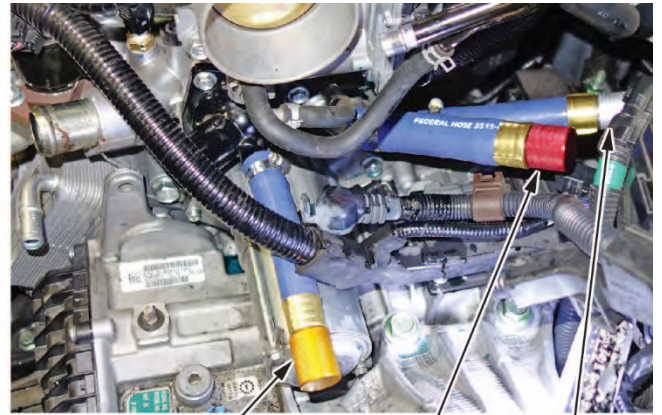

YELLOW PLUG
(ATF WARMER LINE)

RED PLUG
(HEATER
HOSE)

SILVER PLUG
(HEATER
HOSE)

10. Using commercially-available clamps, clamp the throttle body coolant lines as shown.

Clamp both of the throttle body coolant lines.

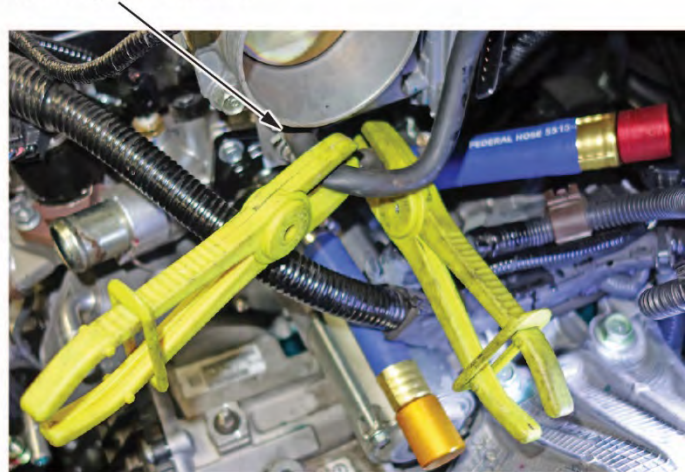

11. From the bucket marked SUPPLY, remove the lid and install the large (1.5 in.) return hose with the T-fitting through the hole in the lid as shown.



ENGINE RETURN HOSE

T-FITTING

SUPPLY BUCKET

12. Install the thermostat adaptor to the pump outlet hose.

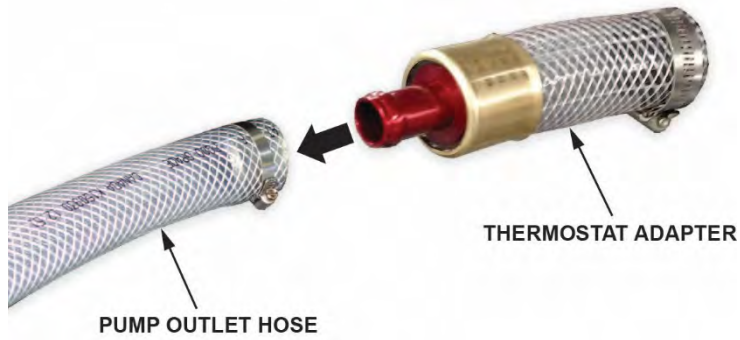

13. Install the pump outlet hose onto the thermostat housing.



14. Install the return hose onto the water passage as shown, fill the bucket with 4.5 gallons of fresh water, and install the lid.

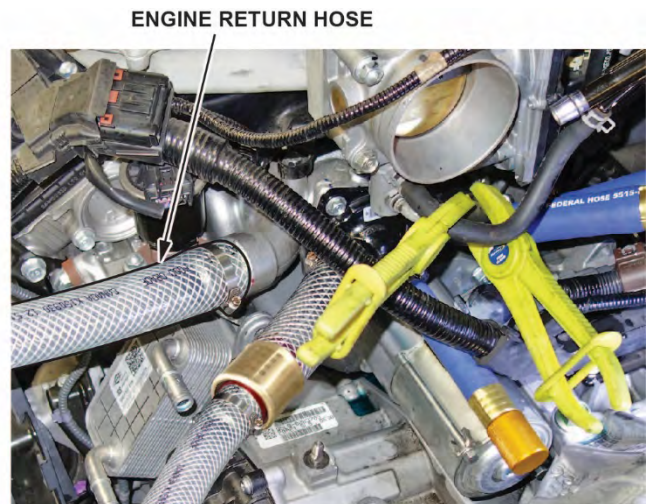

15. Install the pump inlet line to the SUPPLY bucket lid as shown.

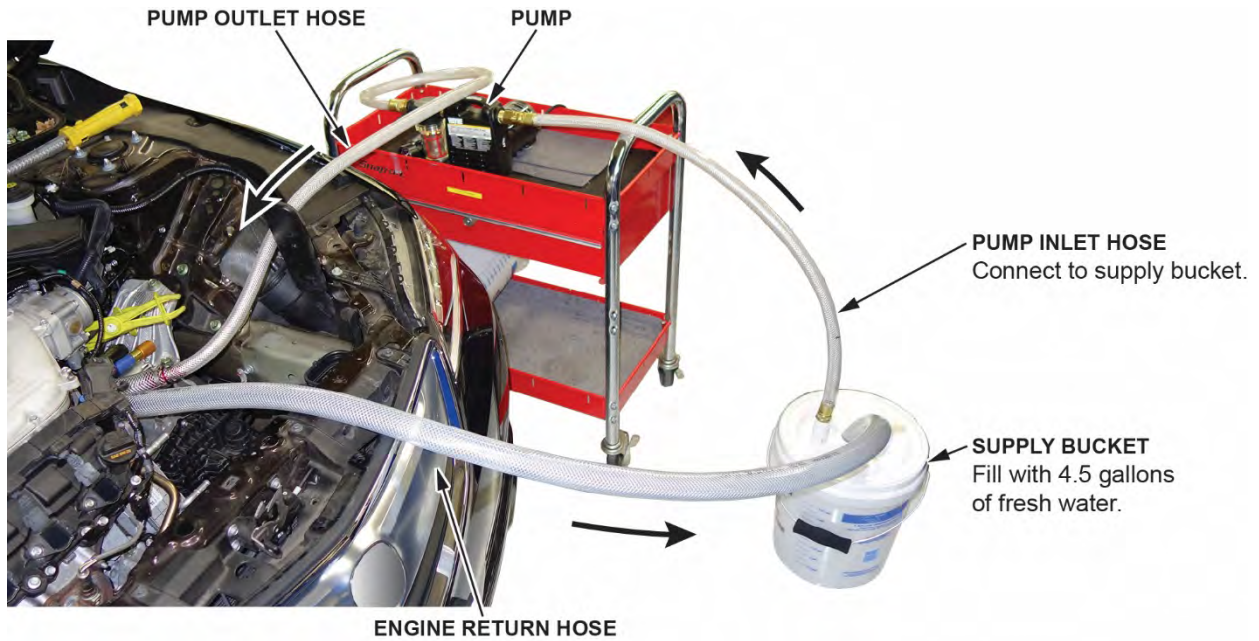

NOTE: If this is the first time using the pump, remove the priming plug, fill the pump with clean water, then reinstall the plug.



16. Turn on the pump, and let it run for 10 minutes.
17. After 10 minutes, turn the pump off and dump all the contents of the SUPPLY bucket into the waste coolant container. Wipe off any oil residue from the bucket, refill the bucket with water, then repeat the flush 4 more times (50 minutes total time flushing with water).

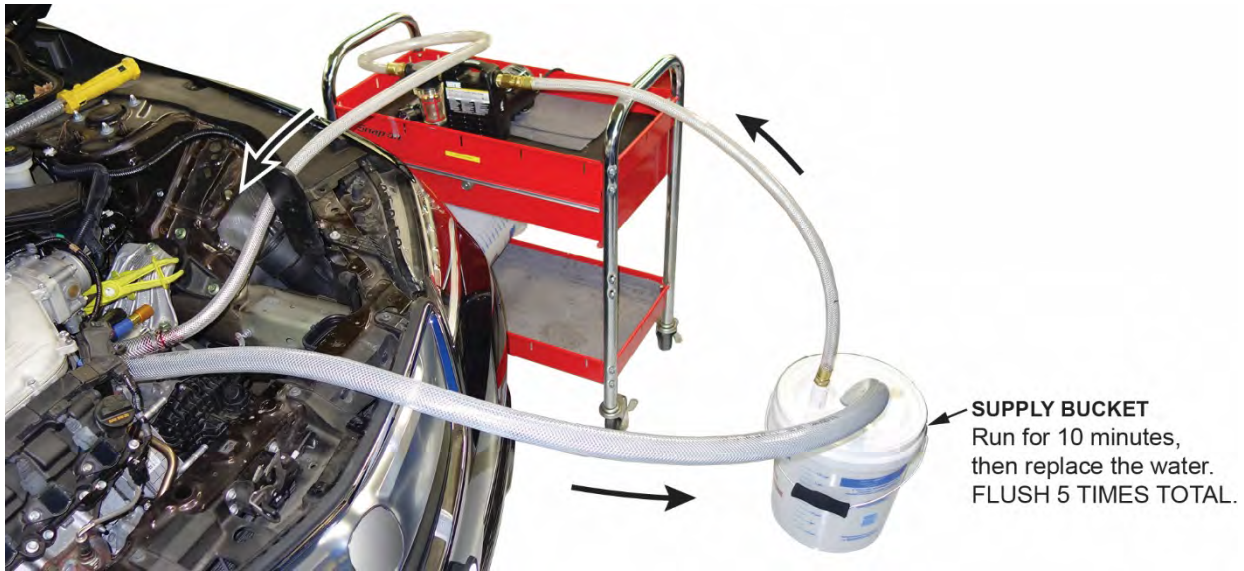

18. Substitute the water for coolant (OL999-9011A), and run the pump for 10 minutes to circulate the fluid.

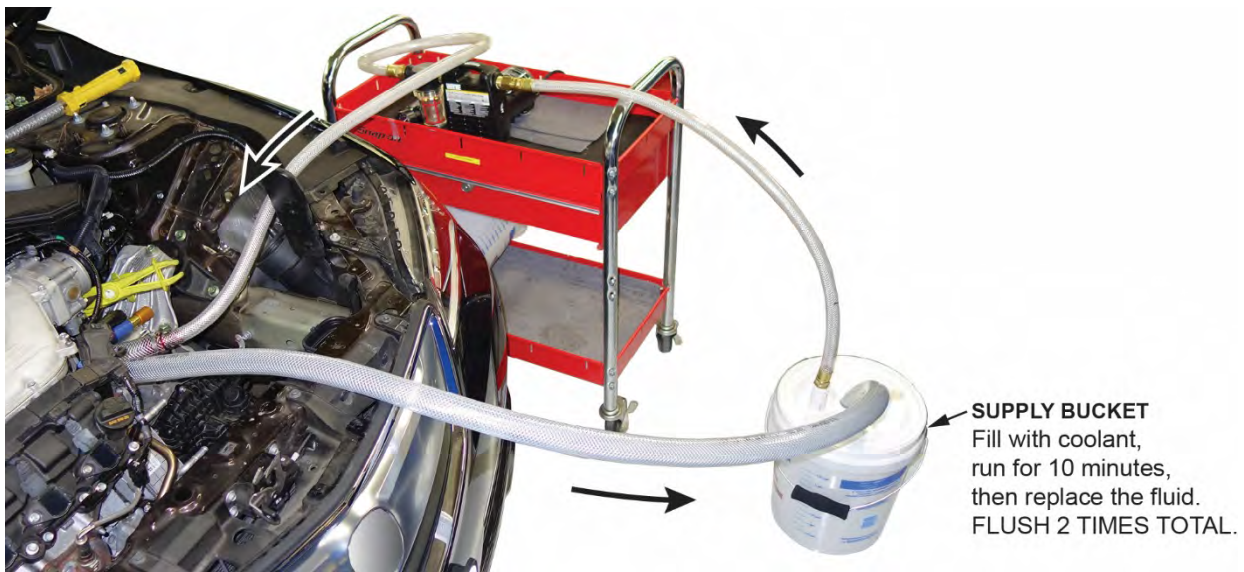

19. After 10 minutes, turn the pump off and dump all the contents of the SUPPLY bucket into the waste coolant container. Refill the SUPPLY bucket with coolant, and run the pump for 10 minutes.

20. Disconnect the pump outlet line from the engine and remove the thermostat adaptor. Replace the outlet adaptor with the 0.75 in. heater hose adaptor.

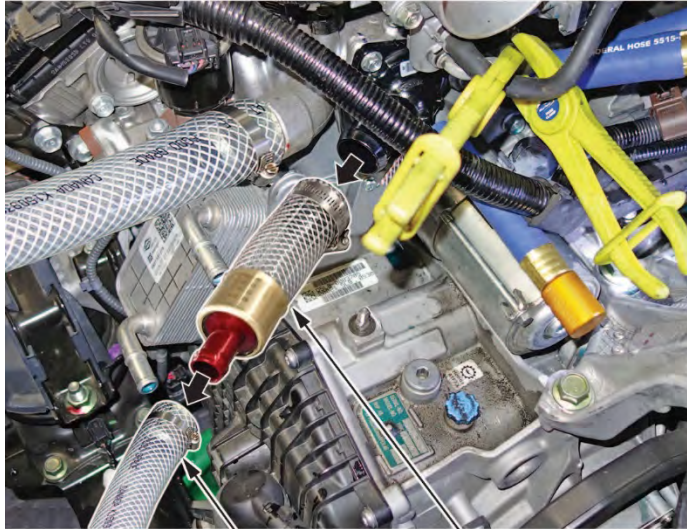

PUMP OUTLET HOSE
Disconnect.

THERMOSTAT ADAPTER

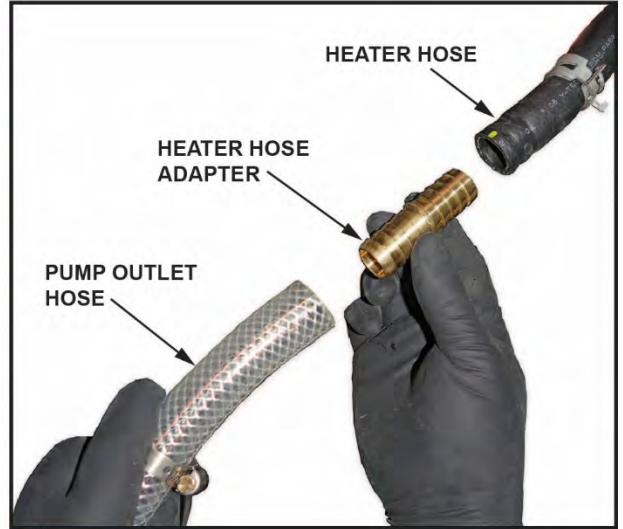

HEATER HOSE

HEATER HOSE ADAPTER

PUMP OUTLET HOSE

21. Remove the thermostat cover, remove the green rubber plug, and return it to the coolant flush kit. To prevent the plug from falling into the water passage, cover the passage with a shop towel.

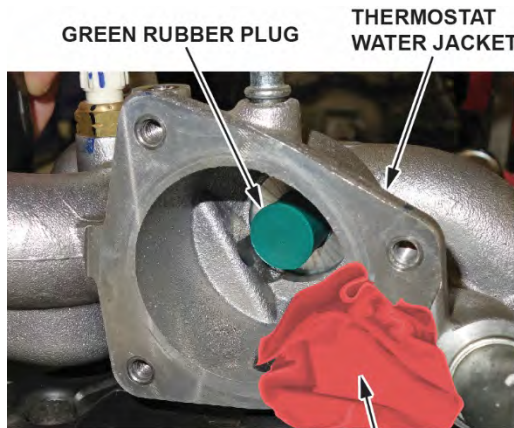

GREEN RUBBER PLUG

THERMOSTAT WATER JACKET

SHOP TOWEL



22. Connect the pump outlet hose to the heater hose as shown.



HEATER HOSE

PUMP OUTLET HOSE

23. Install the heater core return hose through the DUMP bucket lid.



HEATER CORE RETURN HOSE

T-FITTING

DUMP BUCKET

24. Attach the heater core return hose to the heater hose as shown.

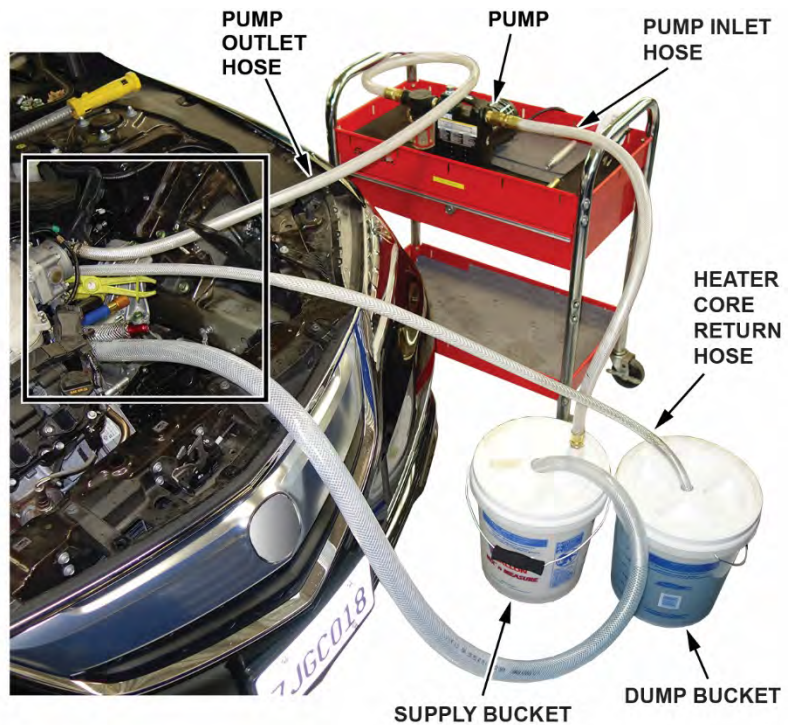
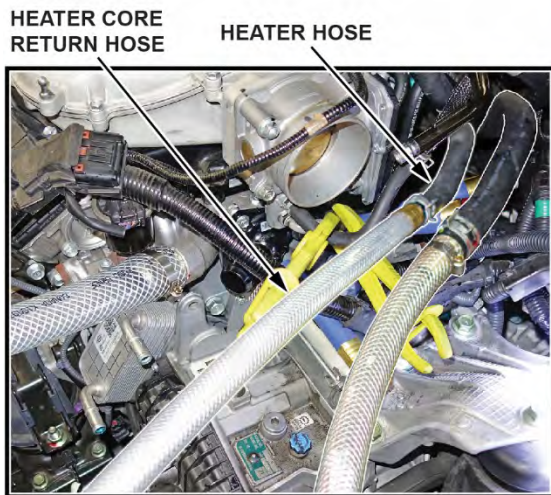

SUPPLY BUCKET

DUMP BUCKET

25. Fill the SUPPLY bucket with water, and run the pump until the SUPPLY bucket is empty.

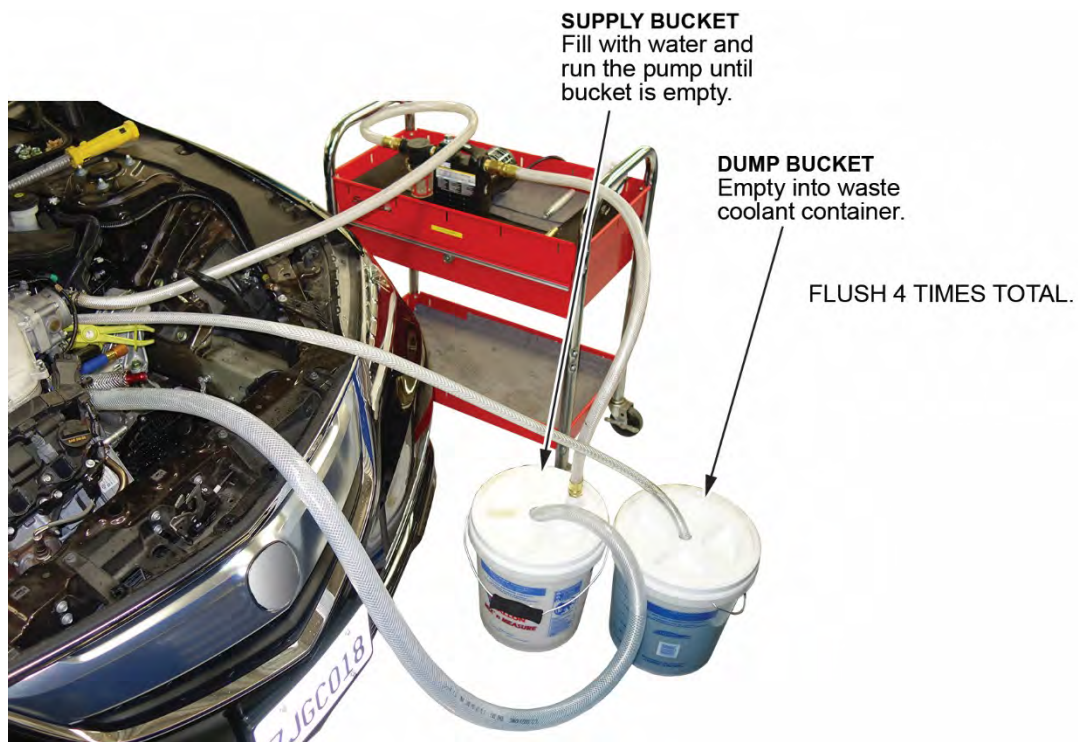

26. Empty the DUMP bucket into the waste coolant container.

27. Repeat the flush (steps 25 and 26) 3 more times.

28. Empty the DUMP bucket into the waste coolant container and wipe off any oil residue from the bucket.

29. Remove the pump and return hoses, throttle body hose clamps and the three colored plugs from the vehicle.

Reassemble Vehicle

30. Replace the radiator, the 10 indicated coolant hoses, thermostat, coolant reserve and hoses, and the 2 ECT sensor (1 and 2) O-rings. Refer to the image for the location of all the components.

NOTE:

- **Make sure to remove the rubber plug that was installed in the thermostat water jacket and return it to the flush kit.**
- **When refilling the cooling system after the flush is complete, some oil may be present in the cooling system. Thorough testing has shown the amount left over after the flush procedure is within acceptable limits provided the flush procedure was followed completely.**

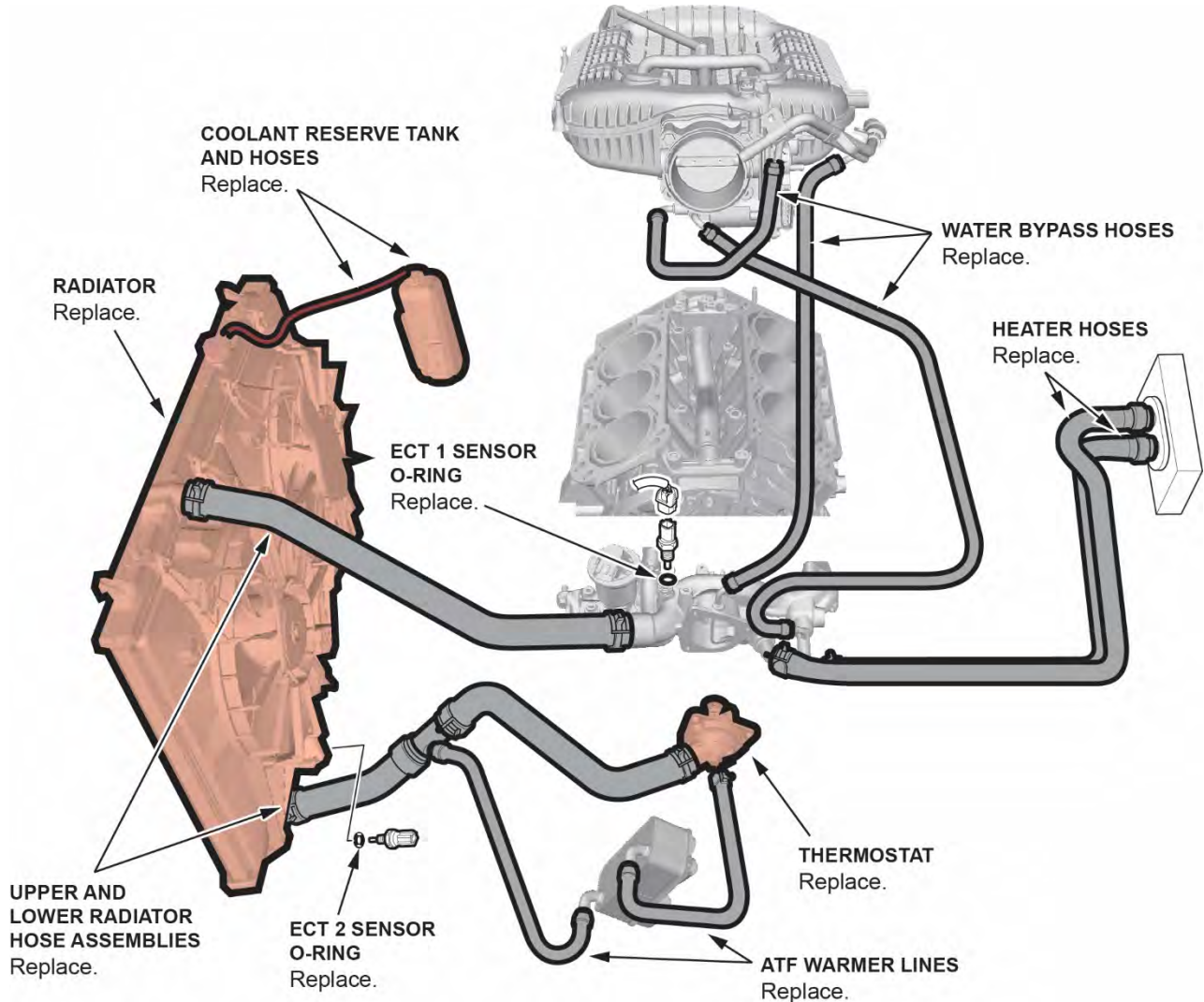

31. Install the remanufactured transmission. To ensure proper shift quality, update the TCM and PCM as necessary, then do the PCM idle learn, teach-in (Hydraulic Pressure Characteristic Calibration), and adaptation (see Tech2Tech listed below). Refer to the service information.

PCM

Trim	Program IN (or later)	Program P/N (or later)
2015-16 Base Tech	J23050	37805-5J2-3050
2015-16 ADV	J23060	37805-5J2-3060
2015-16 Tech AWD	J23070	37805-5J2-3070
2015-16 ADV AWD	J23090	37805-5J2-3090

TCM

Trim	Program IN (or later)	Program P/N (or later)
2015–16 2WD Base, Technology	J4A590	28101-5J4-A590
2015–16 2WD Advance	J4A690	28101-5J4-A690
2015–16 AWD Base, Technology	L9A700	28101-5L9-A700
2015–16 AWD Advance	L9A690	28101-5L9-A690

- Automatic Transmission Removal and Installation
- [Tech2Tech “Power Up a One-Push Start Vehicle with the i-HDS – With Replaced Components”](#)
- [Tech2Tech “9-Speed Transmission or TCM Replacement Procedure”](#)

END

REPAIR PROCEDURE D

NOTE:

- Use this procedure only if the transmission warmer failed the pressure test and the engine overheated. If the engine did not overheat, go to REPAIR PROCEDURE C.
 - Fill in the heater core part of the flush work sheet (see page 58), and attach it to the RO.
1. Remove the engine and transmission assembly. Refer to the service information.

Heater Core Flush Procedure

2. Connect the pump to the SUPPLY bucket.

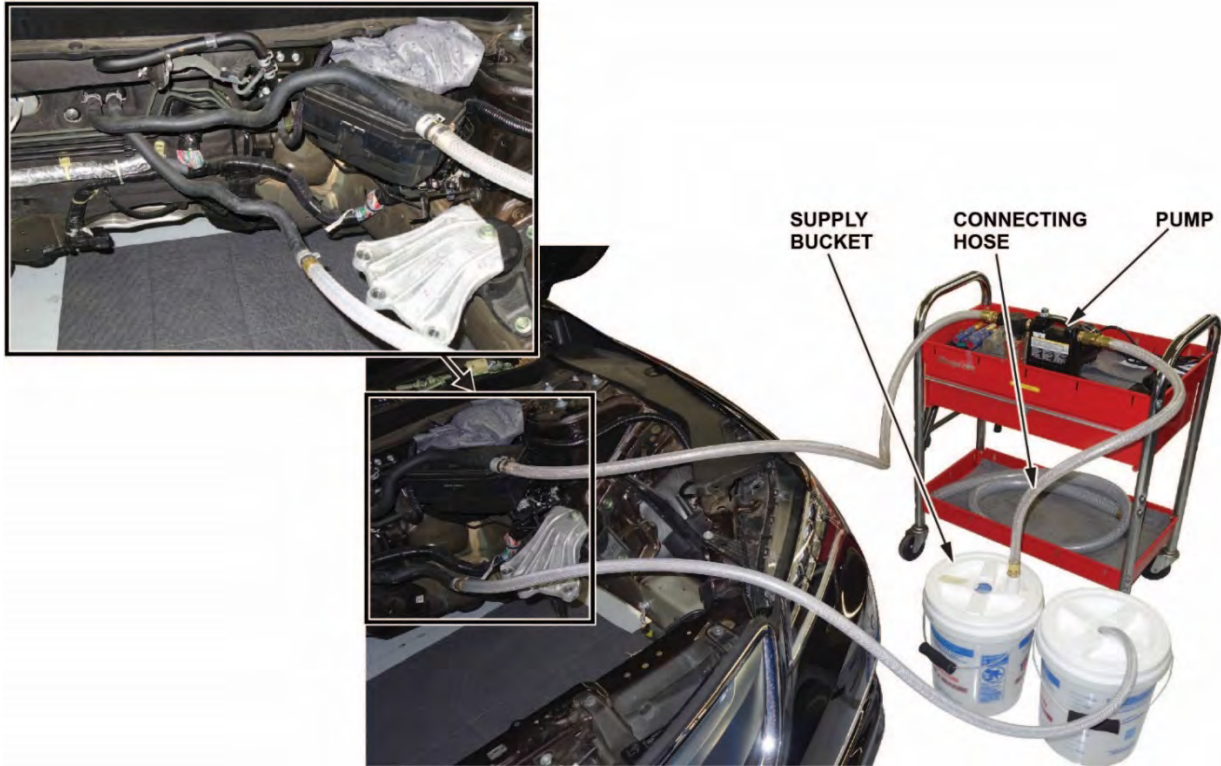

3. Make sure the 0.75 in. heater hose adaptor is installed on the pump outlet hose, then connect the pump outlet hose to the heater hose as shown.

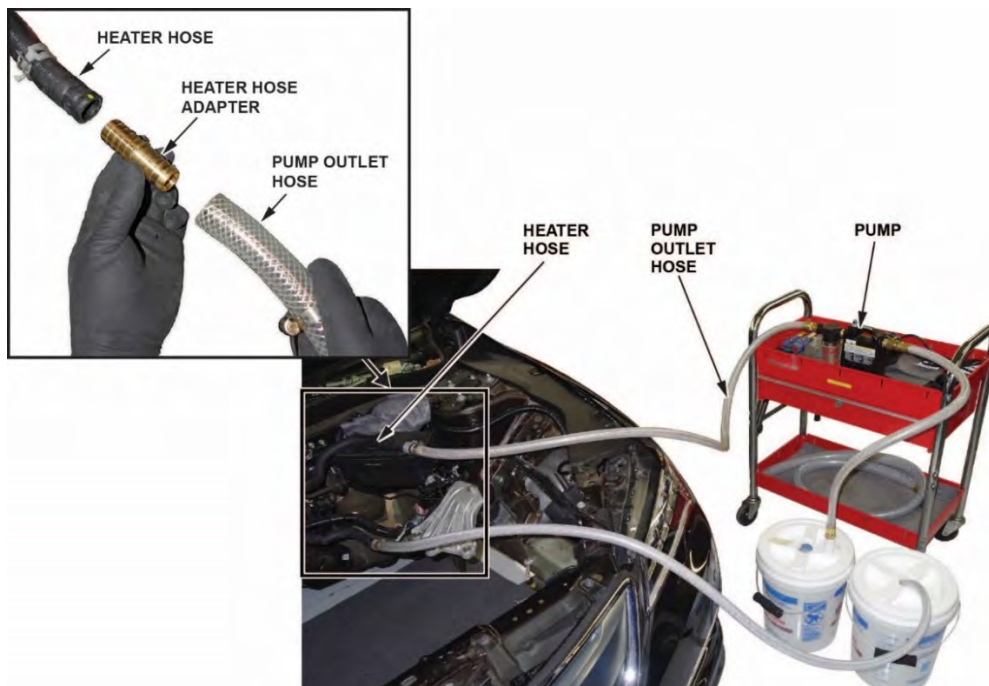

4. Install the return hose through the DUMP bucket lid, then install the lid on the bucket.

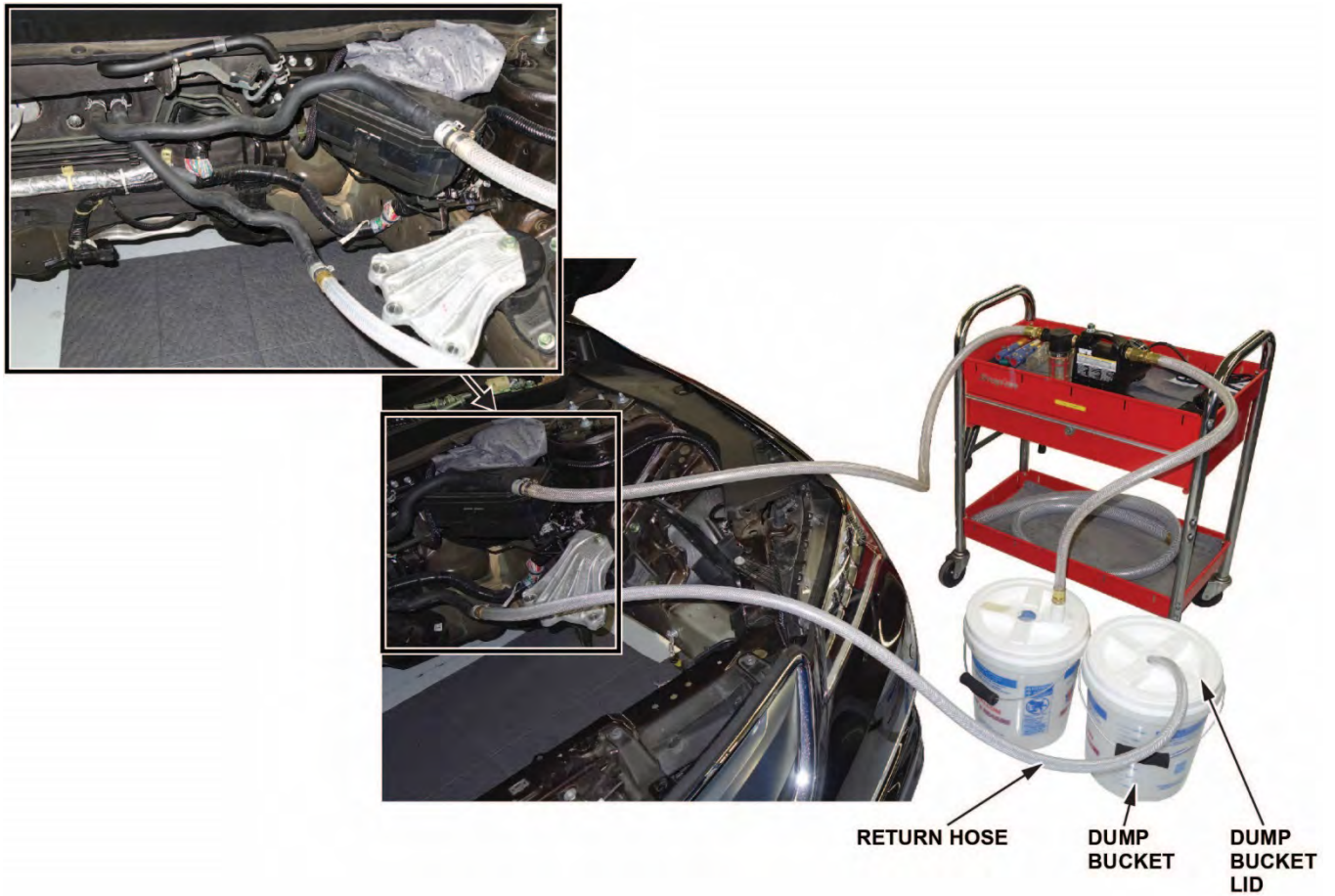

5. Attach the return hose to the heater hose as shown.

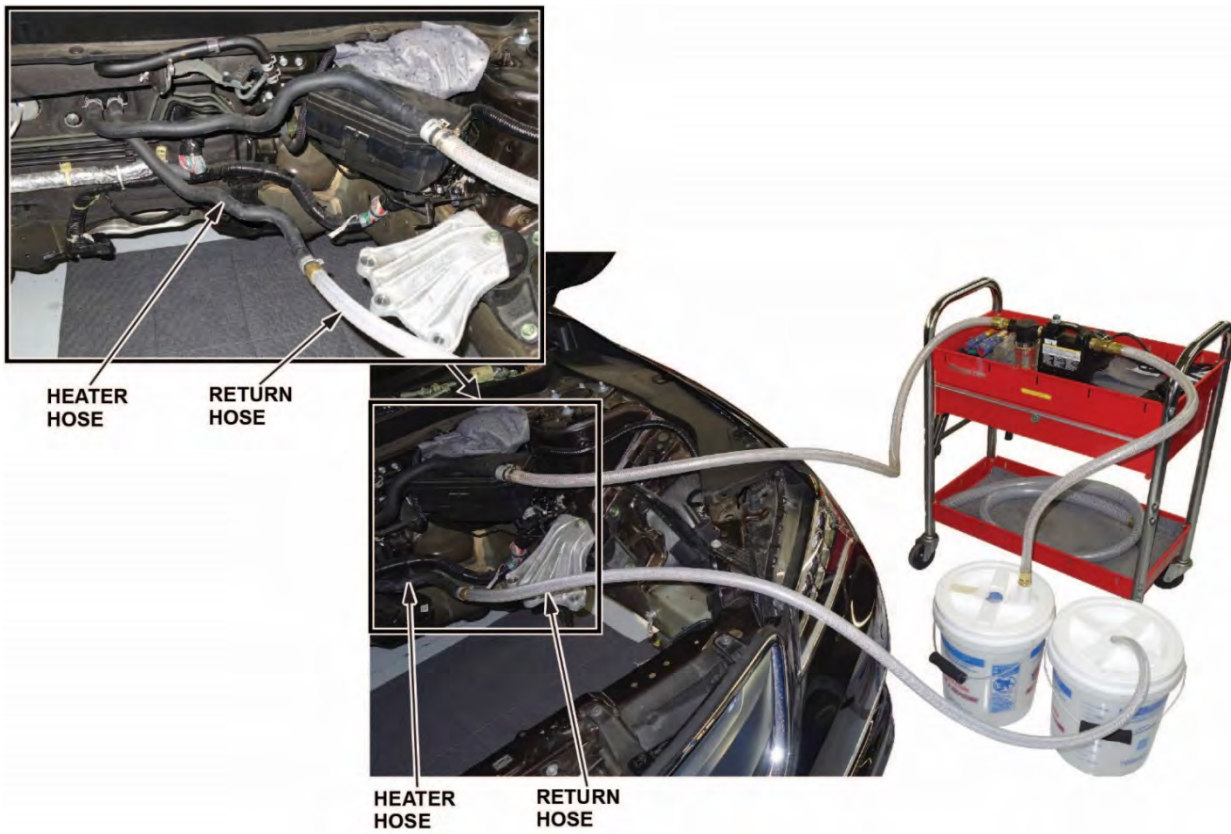

6. Fill the SUPPLY bucket with water, and run the pump until the SUPPLY bucket is empty.



SUPPLY BUCKET
Fill with water and
run the pump until
bucket is empty.

DUMP BUCKET
Empty into waste
coolant container.



FLUSH 4 TIMES TOTAL.

NOTE: If this is the first time using the pump, remove the priming plug, fill the pump with clean water, then install the plug.

PRIMING PLUG



CLEAN WATER



7. Empty the DUMP bucket into the waste coolant container.
8. Repeat the flush 3 more times.
9. Empty the DUMP bucket into the waste coolant container, and wipe off any oil residue from the bucket.
10. Remove the pump and return hose from the vehicle.

Reassemble Vehicle

11. Install a new short block, water connecting pipe, water passage, new cylinder heads, and a remanufactured transmission.
12. Replace the radiator, the 10 indicated coolant hoses, the thermostat, the water passage and water connecting pipe, the coolant reserve tank, the 2 ECT sensor (1 and 2) O-Rings, and the coolant reserve tank and hoses. Refer to the image for the location of all the components.

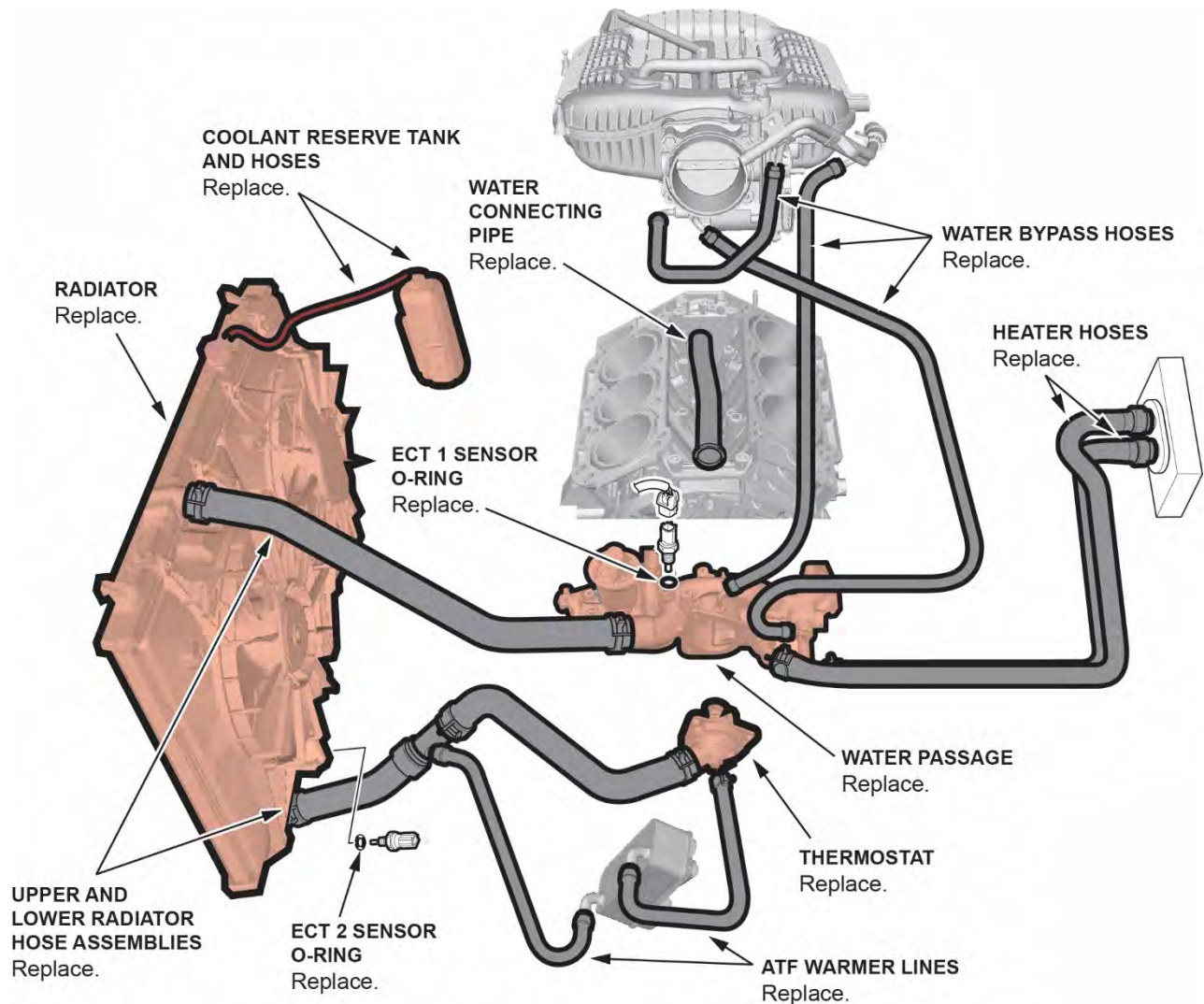

13. To ensure proper shift quality, update the TCM and PCM as necessary, then do the PCM idle learn, teach-in (Hydraulic Pressure Characteristic Calibration), adaptation (see Tech2Tech listed below), and CKP-pattern learn. Refer to the service information.

PCM

Trim	Program IN (or later)	Program P/N (or later)
2015-16 Base Tech	J23050	37805-5J2-3050
2015-16 ADV	J23060	37805-5J2-3060
2015-16 Tech AWD	J23070	37805-5J2-3070
2015-16 ADV AWD	J23090	37805-5J2-3090

TCM

Trim	Program IN (or later)	Program P/N (or later)
2015–16 2WD Base, Technology	J4A590	28101-5J4-A590
2015–16 2WD Advance	J4A690	28101-5J4-A690
2015–16 AWD Base, Technology	L9A700	28101-5L9-A700
2015–16 AWD Advance	L9A690	28101-5L9-A690

- Automatic Transmission Removal and Installation
- [Tech2Tech “Power Up a One-Push Start Vehicle with the i-HDS – With Replaced Components”](#)
- [Tech2Tech “9-Speed Transmission or TCM Replacement Procedure”](#)

14. Give your warranty clerk the digital photos and RO. For the warranty claim to be paid, the **three photos** must be included in the warranty claim. See ATTACHING PHOTOS TO A CLAIM for information about attaching photos to warranty claims.

END

VIN _____
RO _____

Flush Work Sheet.

(Check each box when completed.)
(Attach to the RO.)

ENGINE FLUSH

Prime pump.

Fill Supply bucket with 4.5 gallons of plain water flush 5 times wiping the bucket out between each flush.

1. Flush with plain water 10 min ____
2. Flush with plain water 10 min ____
3. Flush with plain water 10 min ____
4. Flush with plain water 10 min ____
5. Flush with plain water 10 min ____

Add 4.5 gallons 50/50 mix coolant for the final 2 flushes.

1. Flush with 50/50 mix 10 min ____
2. Flush with 50/50 mix 10 min ____

HEATER CORE FLUSH

Attach flush hoses to heater core. Fill supply bucket with 4.5 gallons of plain water flush 4 times.

1. Flush with plain water ____
2. Flush with plain water ____
3. Flush with plain water ____
4. Flush with plain water ____
5. Disconnect flush hoses ____
6. Remove thermostat ____ plug ____

END

ATTACHING PHOTOS TO A CLAIM

Go to the **Photo Attachments** area of the claim form to upload images as shown below.

1. To attach photos to the claim, click on **Upload Images**.

Sublet Information				
Sublet Code	Invoice No.	Work Description	Sublet Amount	Rental Days
PH	1234567899	ENGINE BLOCK	500.00	
<< SELECT >>				
Upload Images		Photo Attachments	View Images	

The **Claim Photo Attachment** screen appears.

• = Required

Claim Photo Attachment

[Close](#)

Uploaded Images 0 (Maximum 5) Fit To Window Full Size

Browse... Preview Upload

2. Click on **Browse**. The **Choose File to Upload** window appears.

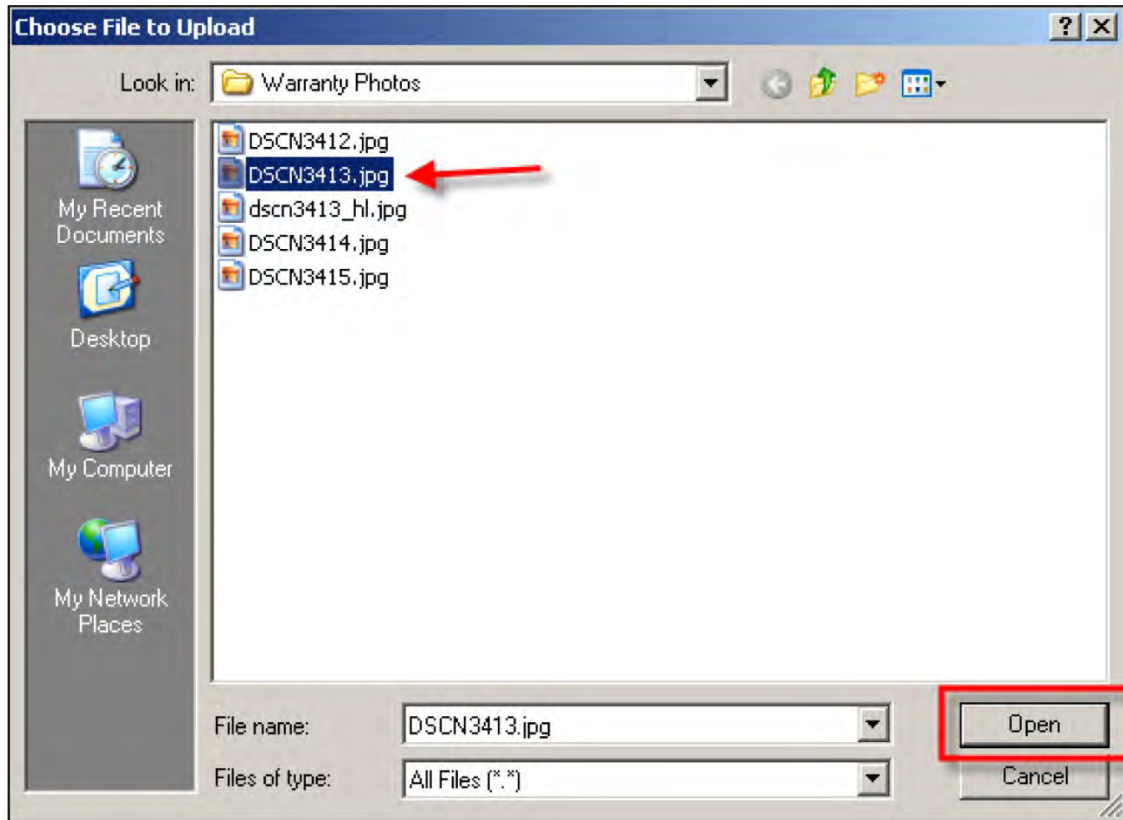

3. Click on an image file to be uploaded.
4. Click on **Open** to select the file.

5. Click on **Preview** if you would like to view the image before uploading. The preview image appears. **Fit To Window** is selected by default as the size at which the preview image is displayed. Click on **Full Size** if you want to enlarge the image, and use the scrollbars to view different areas of the enlarged image.



6. Click on **Upload** to attach the image to the warranty claim. The **Uploaded Images** count increases each time you upload a photo.



7. Click on **Browse** again and follow the same steps to continue attaching images to the claim. To properly document each warranty repair claim, at least 3 photos must be attached.

8. When finished attaching photos, click on **Close**.

The file names of your attached photos now appear in the **Photo Attachments** area of the claim form, as shown below.

Sublet Information				
Sublet Code	Invoice No.	Work Description	Sublet Amount	Rental Days
PH	1234567899	ENGINE BLOCK	500.00	
<< SELECT >>				
Upload Images		Photo Attachments		View Images
dscn3413_hl.jpg	DSCN3412.jpg	DSCN3414.jpg	DSCN3415.jpg	





VIEWING AND DELETING PHOTO ATTACHMENTS

After uploading photo attachments, you can view the photos by clicking on **View Images** in the **Photo Attachments** area. The **Claim Photo Attachment** screen displays thumbnails of all photos attached to the claim.

Sublet Information				
Sublet Code	Invoice No.	Work Description	Sublet Amount	Rental Days
PH	1234567899	ENGINE BLOCK	500.00	
<< SELECT >>				
Upload Images		Photo Attachments		View Images
dscn3413_hl.jpg	DSCN3412.jpg	DSCN3414.jpg	DSCN3415.jpg	

Claim Photo Attachment Close

Images Uploaded: 4 Fit To Window Full Size

- [Delete](#)  dscn3413_hl.jpg
- [Delete](#)  DSCN3412.jpg
- [Delete](#)  DSCN3414.jpg
- [Delete](#)  DSCN3415.jpg



Click on a thumbnail to view the photo attachment as shown above. To delete a photo attachment, simply click on **Delete** to the left of its thumbnail.



When your claim and photos are completely ready, click on **Submit** to send the claim to the American Honda Warranty department.

WARRANTY CLAIM PHOTO ATTACHMENT INQUIRY

After submitting a warranty claim, you can view its photo attachments at any time as follows:

1. Click on **Service > Warranty > Warranty Claim Photo Attachment Inquiry**.
2. Enter any of the following: **Claim Number, VIN, Repair Order Number, or Repair Order Date**.
3. Click on **submit**. Thumbnails of all photos attached to the claim appear, as shown below.
4. Click on any thumbnail to view the photo attachment.

NOTE:

- Photo attachments are archived on the iN for 2 years.
- Whenever you open a saved warranty claim and attach or delete photos, you must either **save** or **submit** the claim to retain your photo attachment changes.

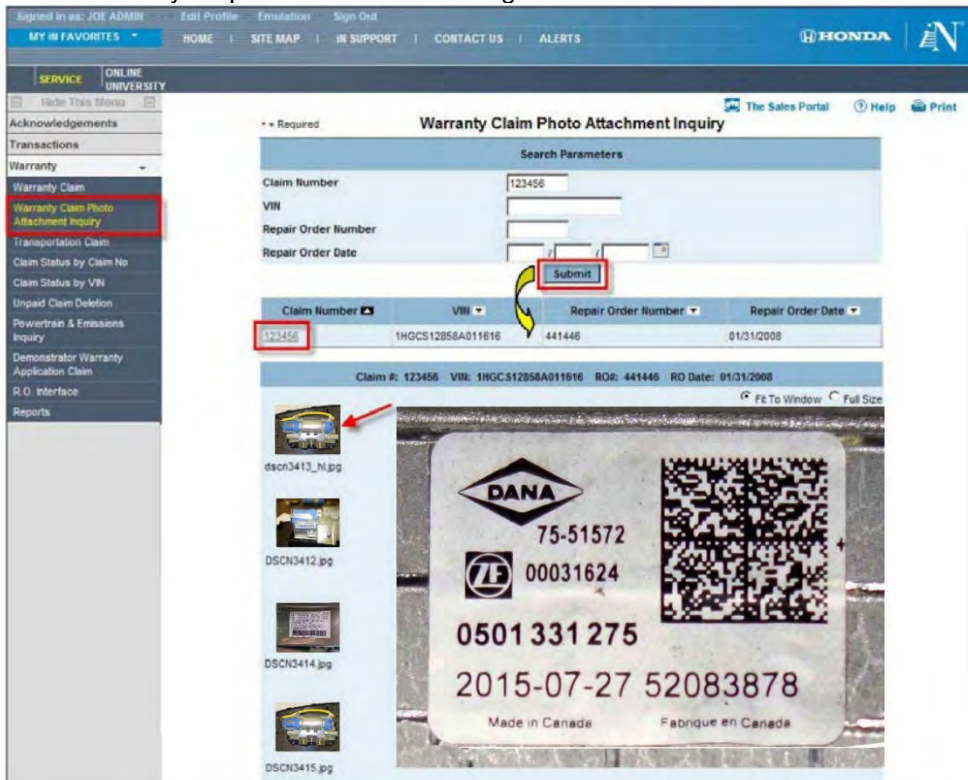

CORRECTING PHOTO PROBLEMS USING PICTURE MANAGER

Microsoft Office Picture Manager is a very useful tool to help improve the quality of photos submitted for warranty consideration.

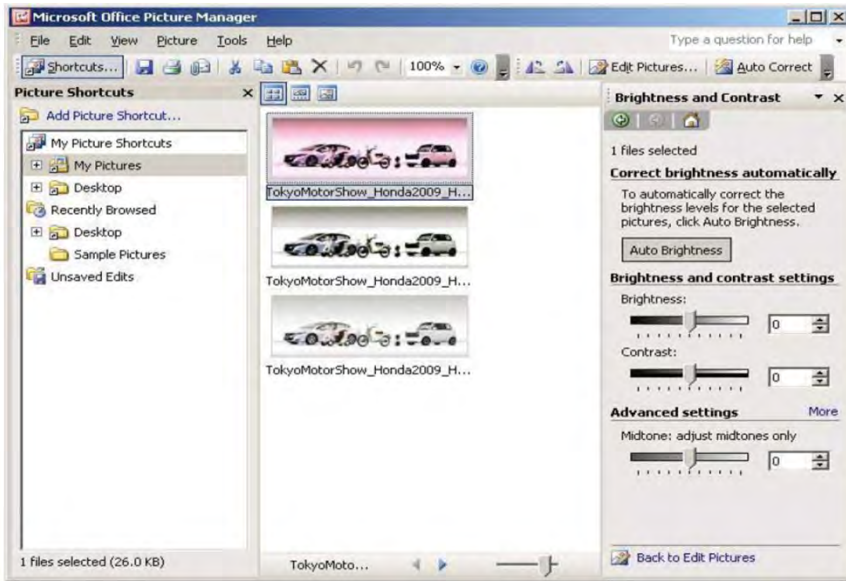

While the Picture Manager program cannot correct blurry, out-of-focus pictures, it can adjust pictures for brightness, contrast, and color, helping to reveal details. It can also crop or resize digital photo files so that they can be submitted for warranty claim consideration.

- To use this program on your PC, click on **Start > Programs > Microsoft Office > Microsoft Office Tools > Microsoft Office Picture Manager**.
- If the above instruction does not lead you to the Picture Manager program, click on **Start > Search**. Under **Search for Folders or Files**, enter **Picture Manager** in the Search window, then click on **Search Now**.
- To create a shortcut to open Microsoft Picture Manager from your desktop, go to **Start > Programs > Microsoft Office > Microsoft Office Tools > Microsoft Picture Manager >**, then right-click and choose **Create Shortcut**. The shortcut icon and title will appear below the original Microsoft Picture Manager icon and title. Left-click and hold on the shortcut icon and drag it to the desktop. Once there, if you wish to change its name, right-click on the icon and select **Rename**.
- To open and edit photos directly from Microsoft Picture Manager, right-click on any JPEG picture file, then move your cursor to **Open with**.

Another window will open listing Microsoft Office Picture Manager and other programs. **Do not** click on **Picture Manager**, but instead scroll down the list, then click on **Choose Program**.

Another window will open, with Picture Manager already selected. Check the open box next to **Always use the selected program to open this kind of file**; this will make Picture Manager your default picture management program.

NOTE: The next time you click on a JPEG photo, it will automatically open in the Picture Manager program.

Correction Example #1: Photo is Too Dark

In Picture Manager, select **Edit/Edit Pictures > Edit Using These Tools/Brightness and Contrast**. Use the sliding scales to adjust the photo to the brightness and contrast that best reveal the fault.

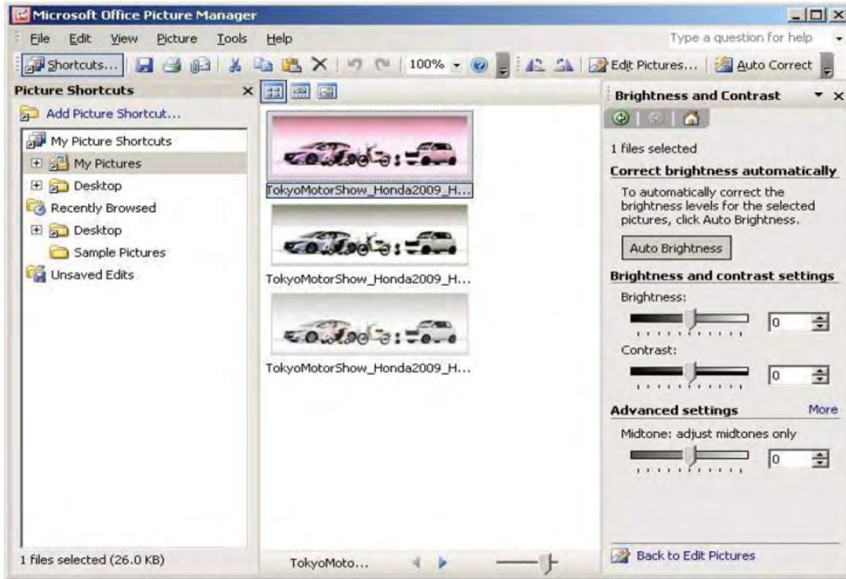

Before Picture Manager Correction

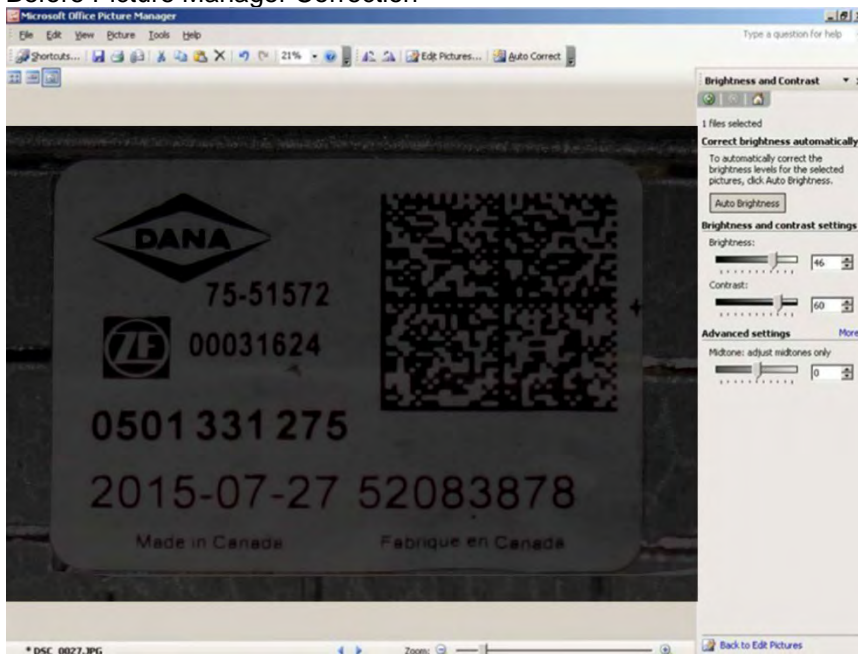

After Picture Manager Correction

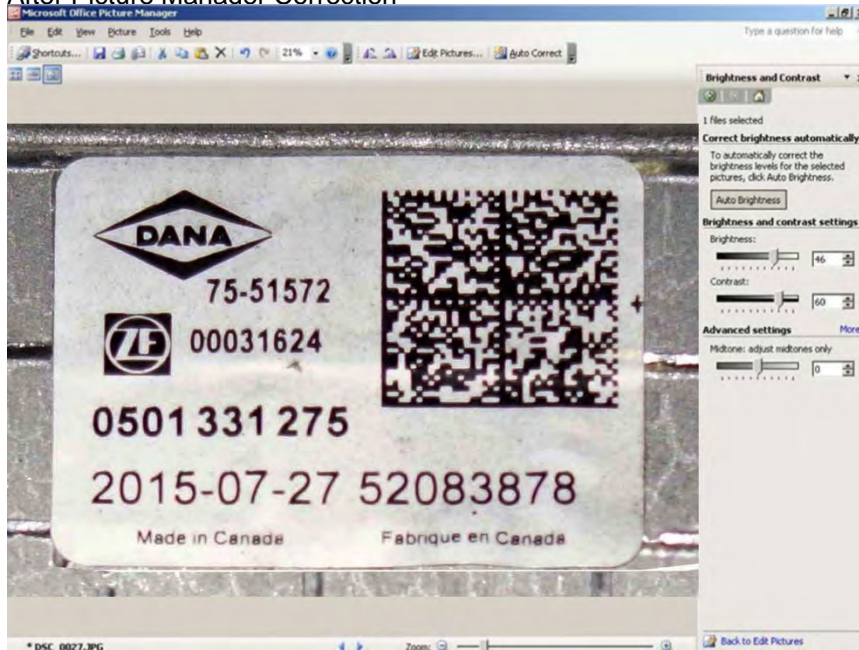

Correction Example #2: Photo Size is Too Large

For maximum clarity, **the file size for each photo must be between 500 kB and 10,000 kB (10 mB)**. ZIP-compressed files are not acceptable. Photo file sizes over 10,000 kB (10 mB) cannot be accepted by the American Honda Warranty department.

To reduce a picture's file size, open Picture Manager. Click on the photo to be reduced, then click on **Edit Pictures > Resize > Percentage of original width x height**, then click on the down arrow to reduce its percentage (%) size. View the pixel count change in **Size Setting Summary**, which displays the photo's **Original size** and its **New size**.

NOTE: The % function changes the pixels per inch, so a photo's size should be reduced only enough to meet the maximum file size requirement. For example, a 10% reduction in pixels per inch will reduce a photo's size and its resolution by almost 50%.

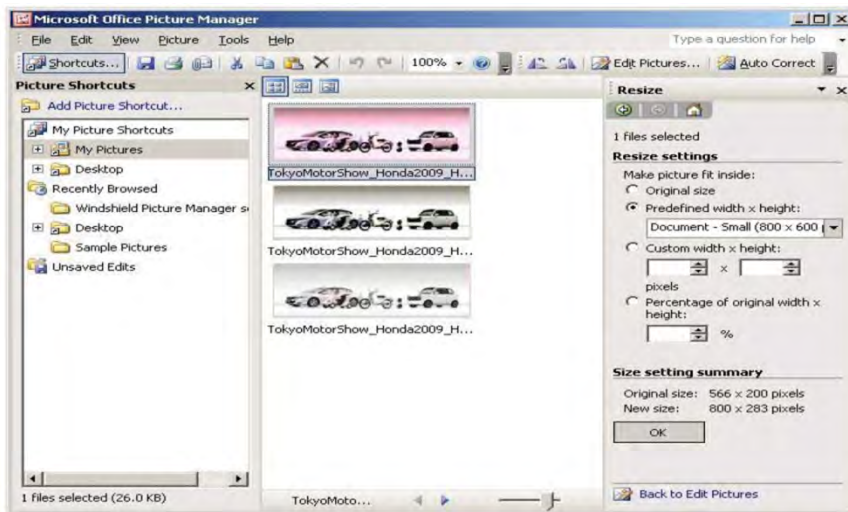

END