



SERVICE CAMPAIGN BULLETIN

Reference:

NTB18-002a

Date:

March 1, 2018

VOLUNTARY SERVICE CAMPAIGN 2016-2017 ROGUE; LEFT HAND ENGINE MOUNTING INSULATOR

This bulletin has been amended. A note with the video link was added to page 2.
No other changes have been made. Please discard all previous versions of this bulletin.

CAMPAIGN ID #: PC601
APPLIED VEHICLES: 2016-2017 Rogue (T32)

**Check Service COMM or Dealer Business Systems (DBS)
National Service History to confirm campaign eligibility.**

INTRODUCTION

Nissan is conducting this Voluntary Service Campaign on certain specific model year 2016 and 2017 Rogue vehicles. This service will be performed at no charge to the customer for parts or labor.

IDENTIFICATION NUMBER

Nissan has assigned identification number PC601 to this campaign. This number must appear on all communication and documentation of any nature dealing with this campaign.

DEALER RESPONSIBILITY

It is the dealer's responsibility to check Service COMM or Dealer Business Systems (DBS) National Service History for the campaign status on each vehicle falling within the range of this voluntary safety recall which for any reason enters the service department. This includes vehicles purchased from private parties or presented by transient (tourist) owners and vehicles in a dealer's inventory. **Federal law requires that new vehicles in dealer inventory which are the subject of a safety recall must be corrected prior to sale. Failure to do so can result in civil penalties by the National Highway Traffic Safety Administration.** While federal law applies only to new vehicles, Nissan strongly encourages dealers to correct any used vehicles in their inventory before they are retailed.

Nissan Bulletins are intended for use by qualified technicians, not 'do-it-yourselfers'. Qualified technicians are properly trained individuals who have the equipment, tools, safety instruction, and know-how to do a job properly and safely. NOTE: If you believe that a described condition may apply to a particular vehicle, DO NOT assume that it does. See your Nissan dealer to determine if this applies to your vehicle.

SERVICE PROCEDURE

NOTE: Before performing this procedure, review the video created for inspection of the engine mount. This video is available in two places:

1. At the bottom of the ASIST screen when the bulletin is being viewed (VIDEO button).
2. In Virtual Academy. See video # 554: "2016-17 ROGUE LEFT HAND ENGINE MOUNT INSULATOR CAMPAIGN". This video is located under the TECH TRAINING GARAGE VIDEOS tab.

1. Place vehicle on a suitable lift but do not lift at this time.
2. Apply parking brake.



Figure 1

3. Turn the ignition ON, engine OFF.
4. Write down the radio settings.

Presets	1	2	3	4	5	6
AM						
FM 1						
FM 2						
SAT 1						
SAT 2						
SAT 3						
Bass	Treble		Balance	Fade	Spd Sen. Vol.	

5. Record (write down) any other customer settings that will be lost when the battery is disconnected.
 - Refer to the Electronic Service Manual (ESM) section PG-Power Supply, Ground, & Circuit Elements, for a listing of systems that may lose settings or memory when disconnecting the 12V battery.
 - Look in the PG section index for ADDITIONAL SERVICE WHEN REMOVING BATTERY NEGATIVE TERMINAL.
 - This list often includes items such as audio, HVAC, power windows, clock, etc.

6. Turn the ignition OFF.
7. Disconnect battery negative terminal.
8. Remove cover on battery positive terminal.
9. Disconnect battery positive terminal.
10. Remove battery frame nuts.
11. Remove battery cover.
12. Remove battery.
13. Remove battery tray liner.

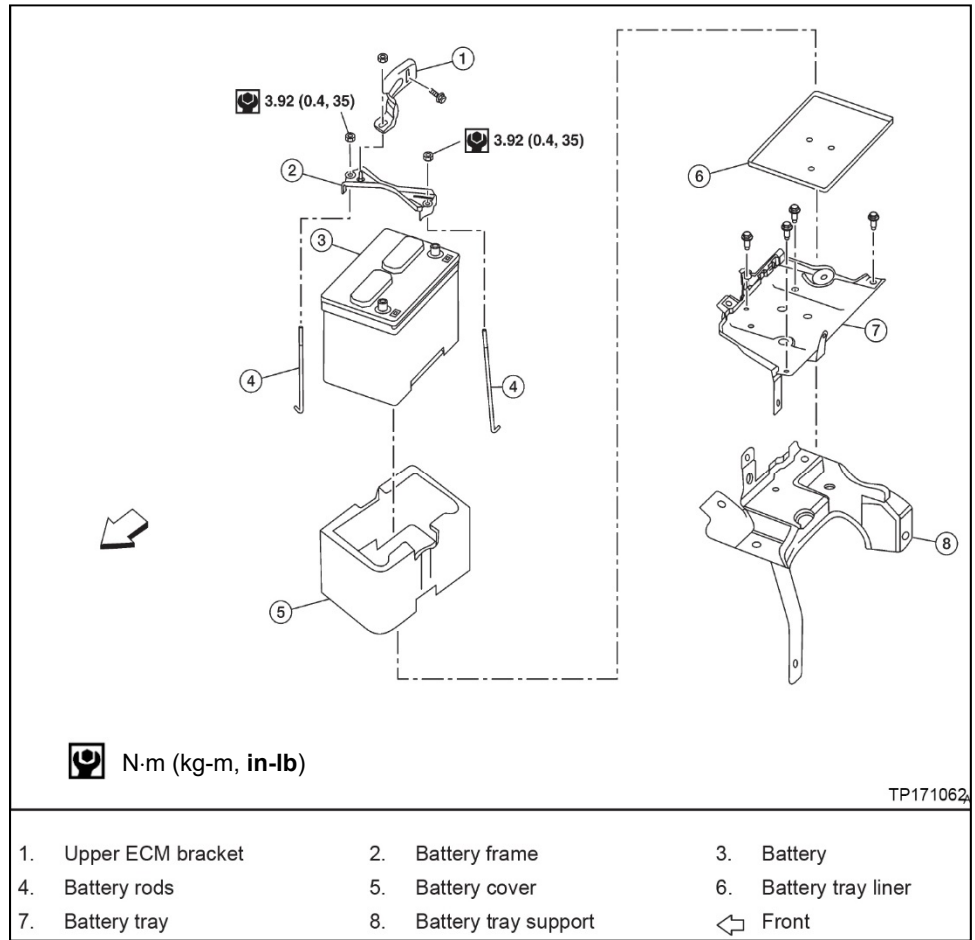

Figure 2

14. Locate the U-shaped hole in battery tray. The engine mounting insulator (LH) casting mark will be viewed at this location in the next step.

CAUTION: Edges around battery tray and U-shaped hole may be sharp.

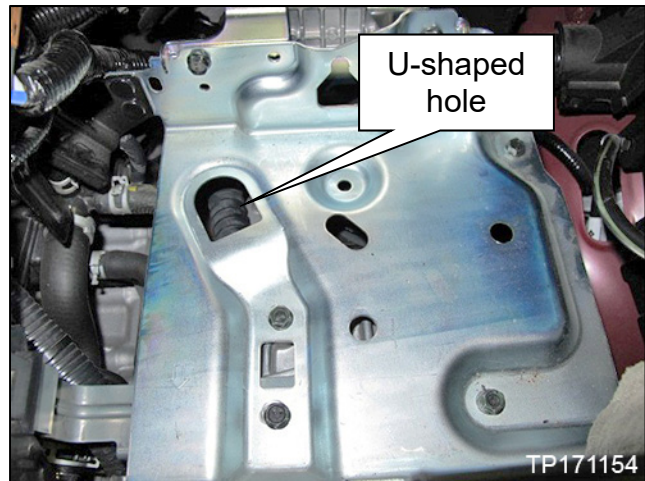

Figure 3

15. Locate the casting mark next to the date stamp. Is the casting mark "C-1"?

YES: Proceed to step 16.

NO: Inspection complete. Proceed to step 77.

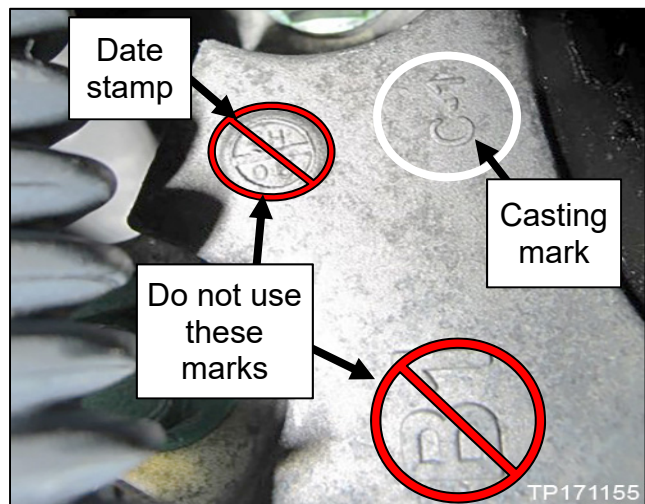

Figure 4

16. Remove the air duct assembly (fore) mounting bolt.

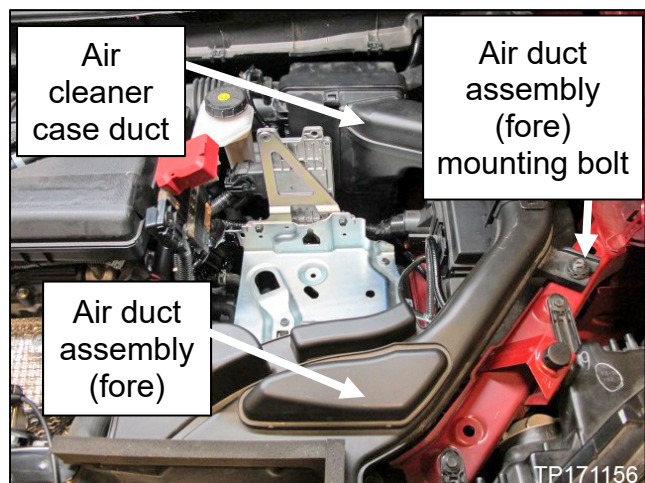

Figure 5

17. Remove the 2 clips from the air duct assembly (fore).

18. Remove the air cleaner case duct and air duct assembly (fore).

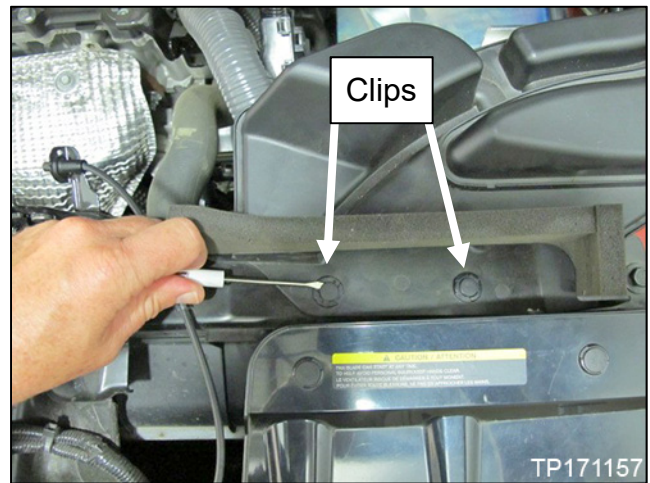

Figure 6

19. Disconnect the 3 ECM connectors.

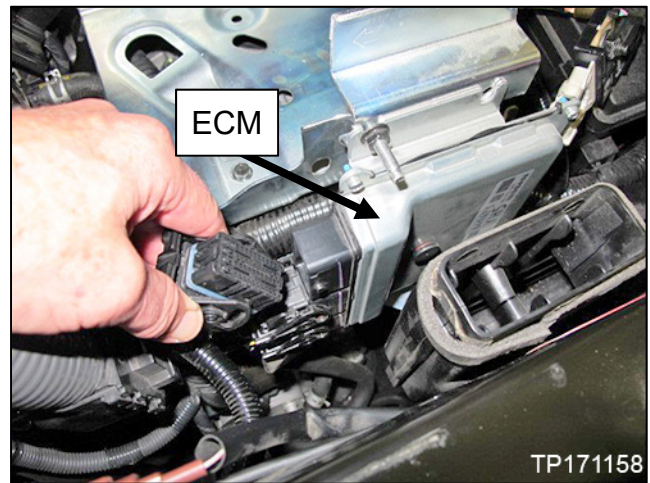

Figure 7

20. Remove the two 2 TCM bracket mounting bolts.

NOTE: Do **NOT** disconnect the TCM electrical connector at this time.

21. Remove the TCM bracket from the battery tray.

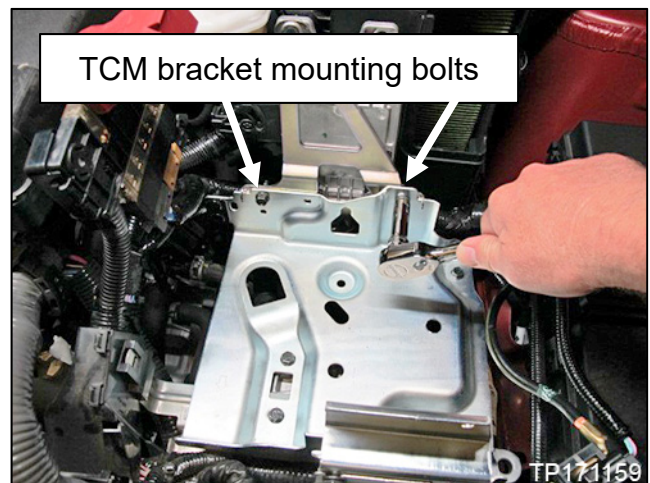

Figure 8

22. Remove the 4 battery tray mounting bolts.

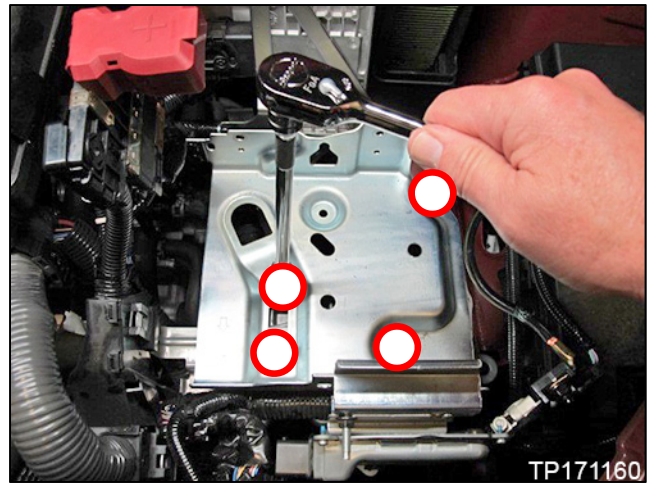

Figure 9

23. Disconnect the tie strap clip from the battery tray support.

- Refer to Figures 10 and 11.

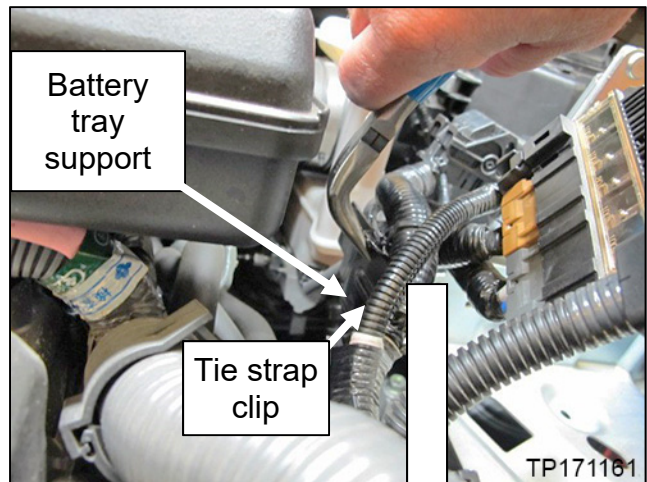

Figure 10

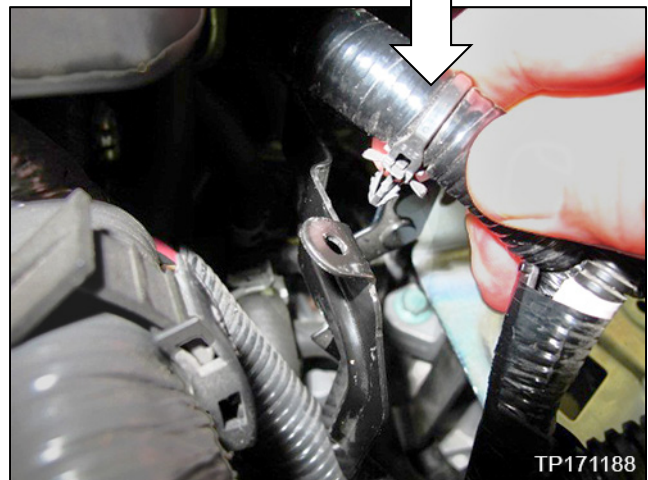

Figure 11

24. Remove the battery tray.

NOTE: The ECM will remain attached to the battery tray.

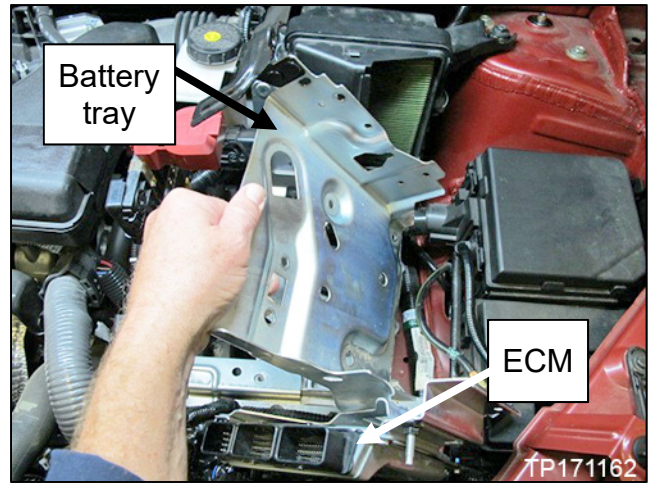

Figure 12

25. Locate the inspection areas on the engine mounting insulator (LH) as shown in Figures 13 and 14.

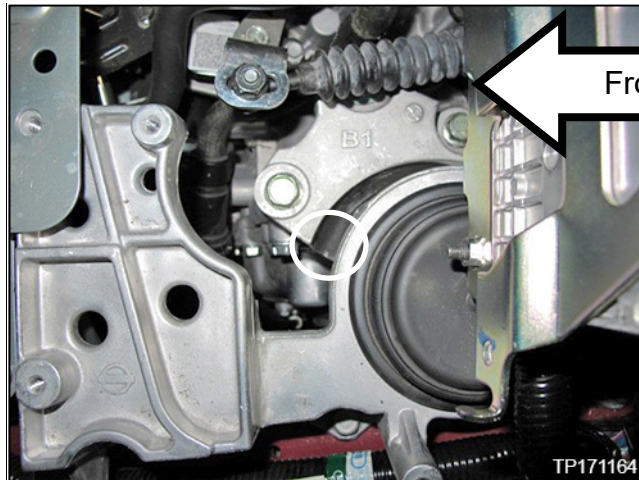

Figure 13

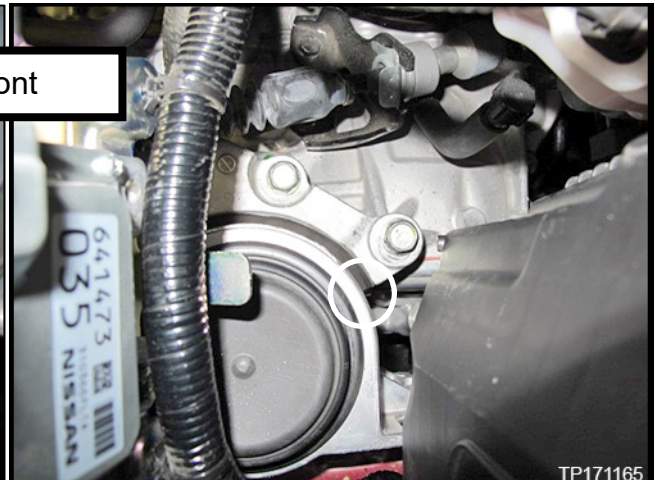

Figure 14

26. Clean the front and rear inspection areas shown in Figure 15 with mild soap and water.

CAUTION: Do NOT use harsh chemicals on engine mounting insulator.

NOTE: Engine mounting insulator (LH) has been removed for clarification.

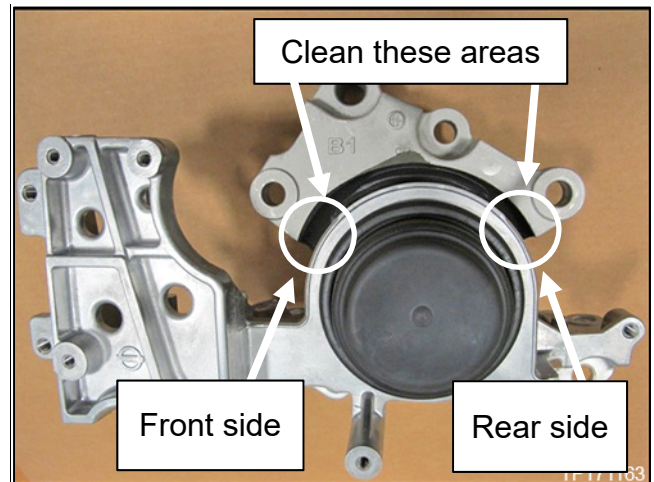

Figure 15

27. Refer to the following list when inspecting the **REAR SIDE** engine mounting insulator (LH) for scratch or dent.

- Dent / scratch will start from the edge of engine mounting insulator (LH) and will run parallel to top surface.
- Dent / scratch distance from top of engine mounting insulator (LH) (Approx. 10 mm).
- Dent / scratch length: (5.0-13.5 mm).
- Dent / scratch depth: (0.01-0.10 mm).

28. Inspect for scratch or dent as shown in Figures 16, 17, and 18. Is there at least one verified dent/scratch mark similar to the examples using specifications in step 27?

YES: Proceed to step 31 to replace the engine mounting insulator (LH).

NO: Proceed to step 29.

The examples in Figures 16, 17, and 18 show a **NO GOOD** engine mounting insulator (LH).

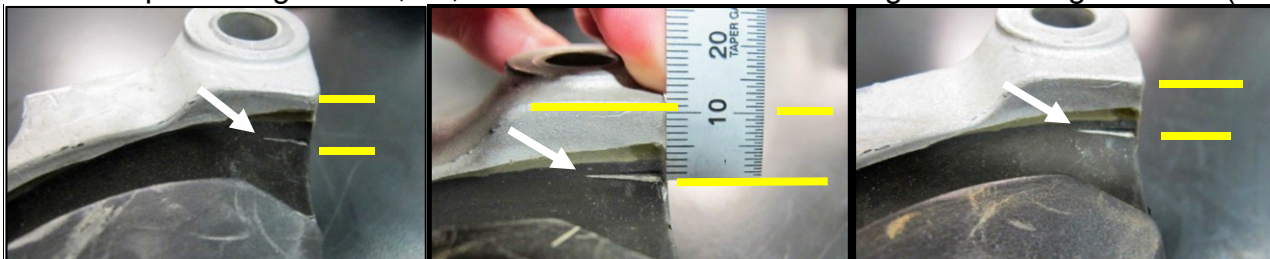

Dent/Scratch mark approximately 10 mm from top of mount.

Figure 16

Figure 17

Figure 18

The examples in Figures 19, 20, and 21 show a **GOOD** engine mounting insulator (LH).



Marks above are commonly mistaken as dent/scratch but are GOOD.

Figure 19

Figure 20

Figure 21

29. Refer to the following list when inspecting the **FRONT SIDE** engine mounting insulator (LH) for scratch or dent.

- Dent / scratch will start from the edge of engine mounting insulator (LH) and will run parallel to top surface.
- Dent / scratch distance from top of engine mounting insulator (LH) (Approx. 3 mm).
- Dent / scratch length: (9.5-12.0 mm).
- Dent / scratch depth: (0.05-0.10 mm).

30. Inspect for scratch or dent as shown in Figures 22, 23, and 24. Is there at least one verified dent/scratch mark similar to the examples using specifications in step 29?

YES: Proceed to step 31 to replace the engine mounting insulator (LH).

NO: Inspection is complete. Proceed to step 71.

The examples in Figures 22, 23, and 24 show a **NO GOOD** engine mounting insulator (LH).

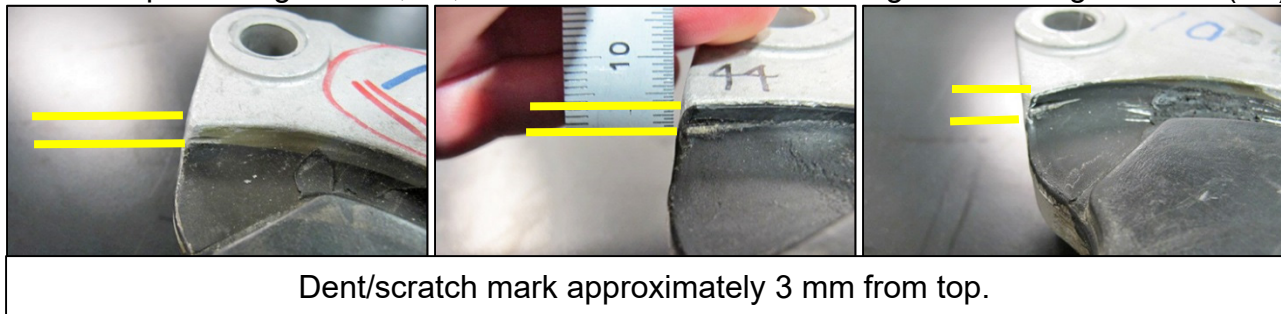

Figure 22

Figure 23

Figure 24

The examples in Figures 25, 26, and 27 show a **GOOD** engine mounting insulator (LH).

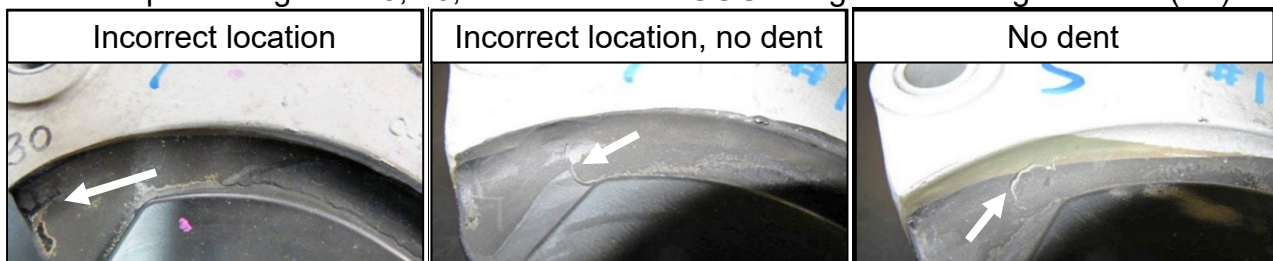

Figure 25

Figure 26

Figure 27

Replace the engine mounting insulator (LH)

31. Remove the 2 ECM harness bracket bolts.

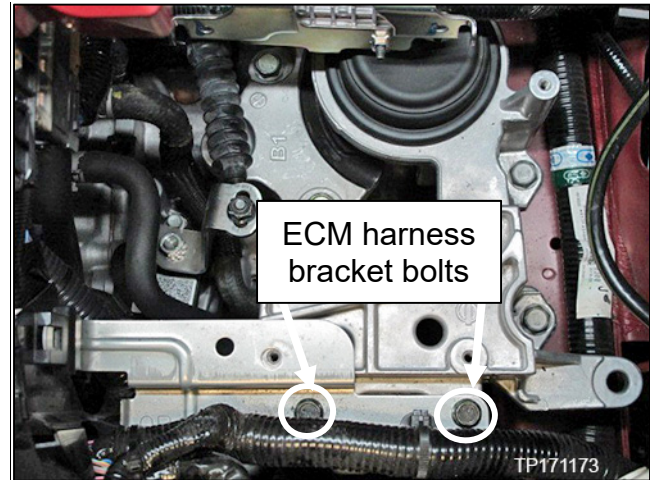

Figure 28

32. Ensure the shift selector is in Park.

33. Note the position of the manual lever and control cable end nut for reassembly.

34. Remove the control cable nut.

IMPORTANT: Ensure vehicle is in park and manual lever does not move from the park position throughout repair.

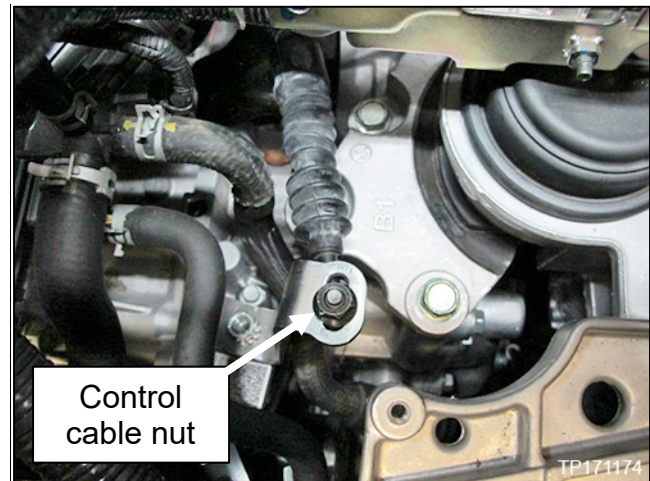

Figure 29

35. Remove the TCM.

- Disconnect the TCM electrical connector.
- Disconnect 2 harness clips attached to the TCM bracket.

NOTE: Engine mounting insulator (LH) has been removed for clarification.

CAUTION: Do not impact the TCM when removing or installing.

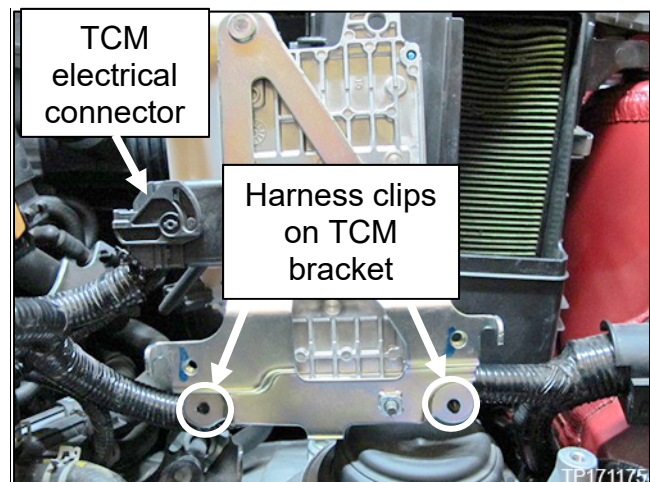

Figure 30

36. Remove the air cleaner case mounting bolt.

37. Loosen the air duct clamp.

38. Separate the air cleaner case from the air duct.

NOTE: Do not disconnect MAF electrical connector. Set to the side.

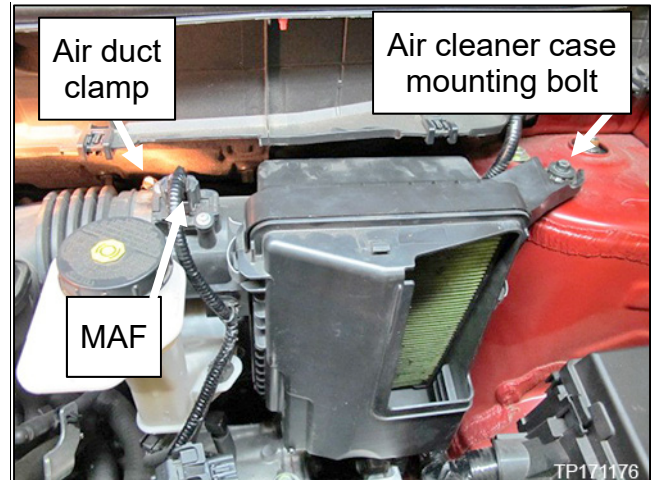

Figure 31

39. Remove the air cleaner bracket bolt.

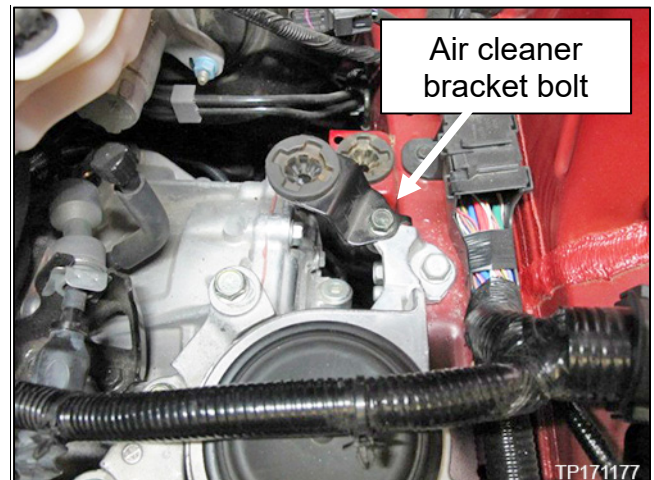

Figure 32

40. Raise the vehicle on the lift and remove the left front wheel and tire assembly.



Figure 33

41. Remove the engine side cover.

- Using a suitable tool release the 6 plastic clips.

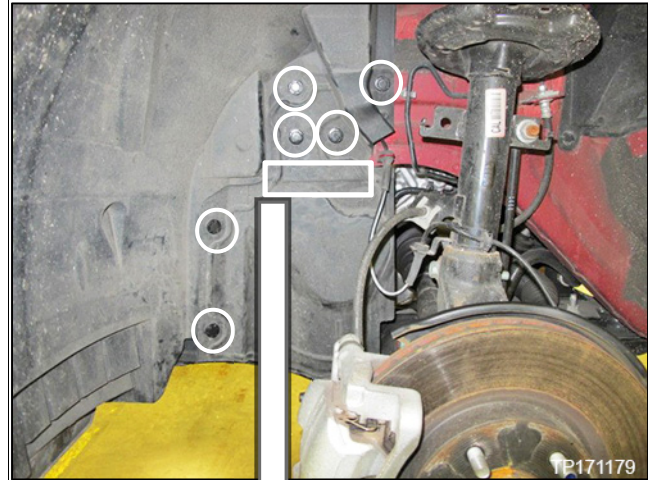

Figure 34

42. Remove the 2 engine mounting insulator (LH) bolts attaching the engine mounting insulator (LH) to the inner lower frame.

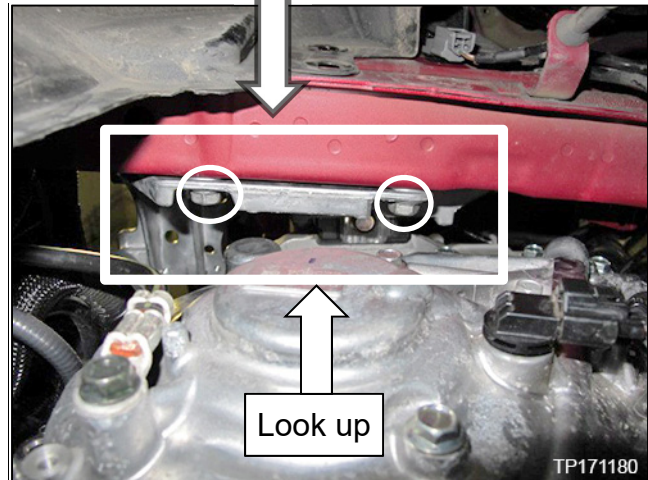

Figure 35

43. Lower vehicle until all three tires are on the ground and front end is level.

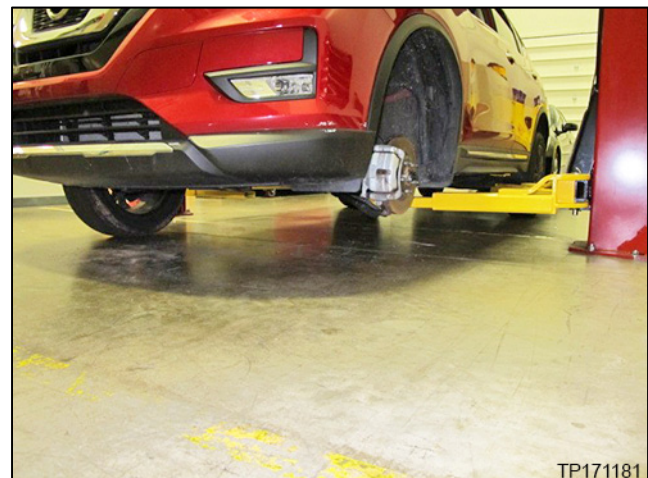

Figure 36

44. Place a floor jack under the CVT in the location shown.

- Raise floor jack until drivetrain moves slightly upward.

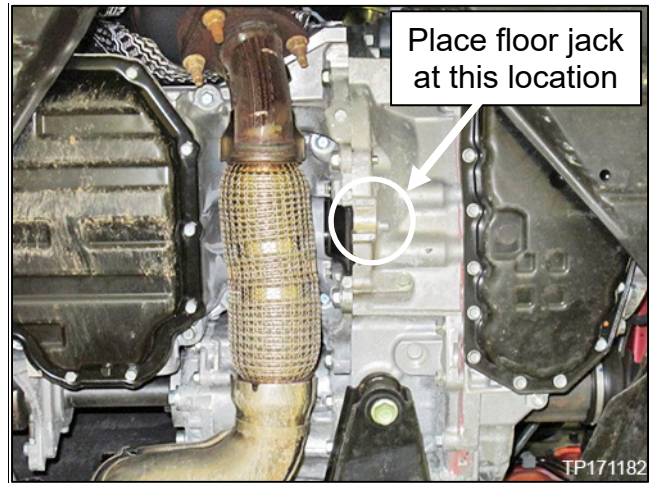

Figure 37

45. Remove the 2 bolts attaching the engine mounting insulator (LH) to the inner frame.

NOTE: Engine mounting insulator (LH) is shown removed for clarification.

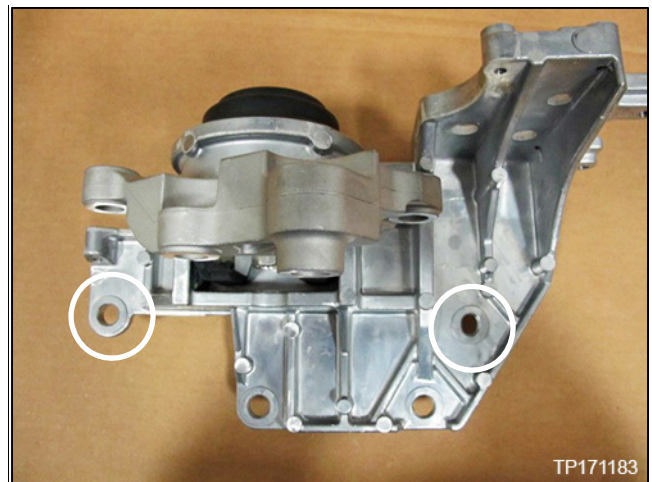

Figure 38

46. Remove the 4 bolts attaching the engine mounting insulator (LH) to the CVT. There is a tapered bolt in location indicated in Figure 39.

CAUTION: Ensure floor jack remains in place until new mount is installed. Removing floor jack prematurely will result in **damage** to the lower torque rod.

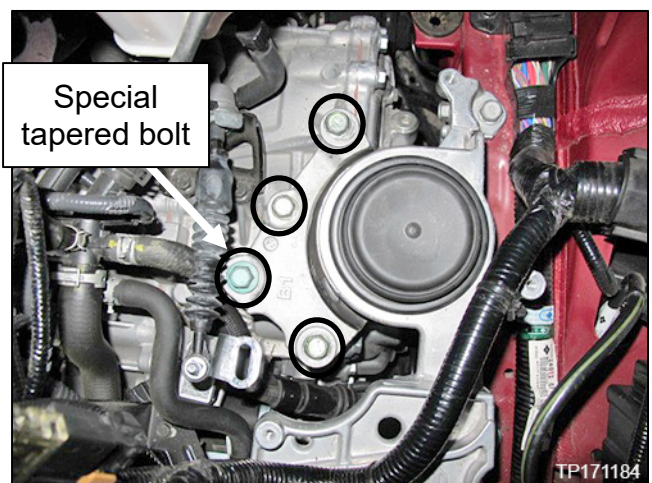

Figure 39

47. Remove the remaining 3 bolts attaching the engine mounting insulator (LH) to the upper side of the frame.

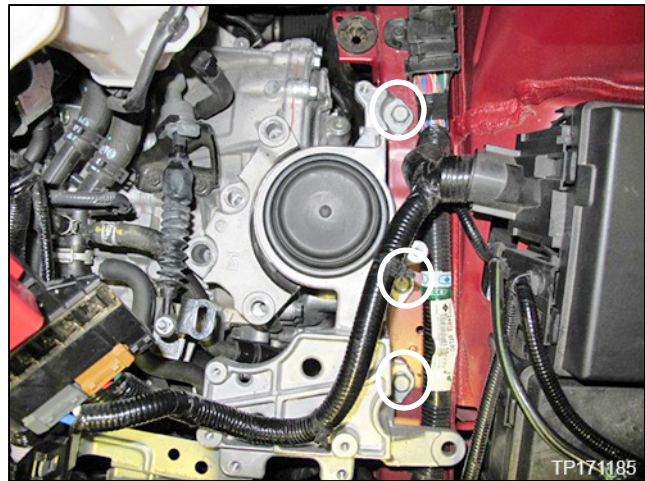

Figure 40

48. Carefully remove the old engine mounting insulator (LH).



Figure 41

49. Carefully install new engine mounting insulator (LH).

- Install bolt 1 (tapered) first then bolts 2, 3 and 4.
- Temporarily hand tighten bolts.

NOTE: Ensure drivetrain is raised high enough to remove any stress when installing and tightening bolts.

CAUTION: Ensure floor jack remains in place until new mount is installed. Removing floor jack before the engine mounting insulator (LH) is torqued could result in damage to the lower torque rod.

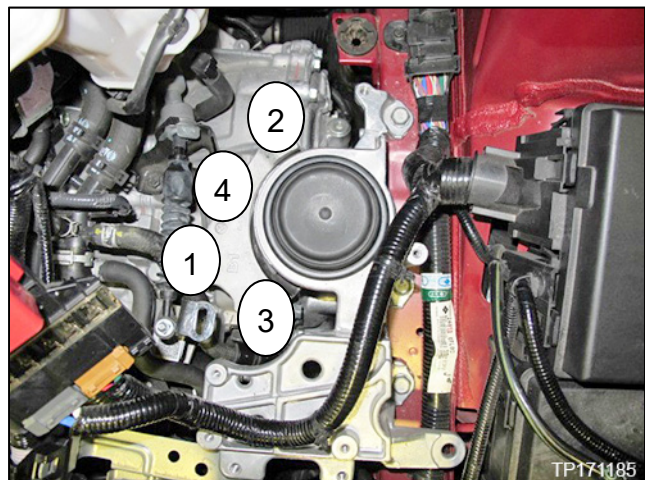

Figure 42

50. Torque the engine mounting insulator (LH) CVT side of the mount.

- Torque Bolts in sequence to 50 N·m, (5.1 kg-m, **37 ft-lb**)

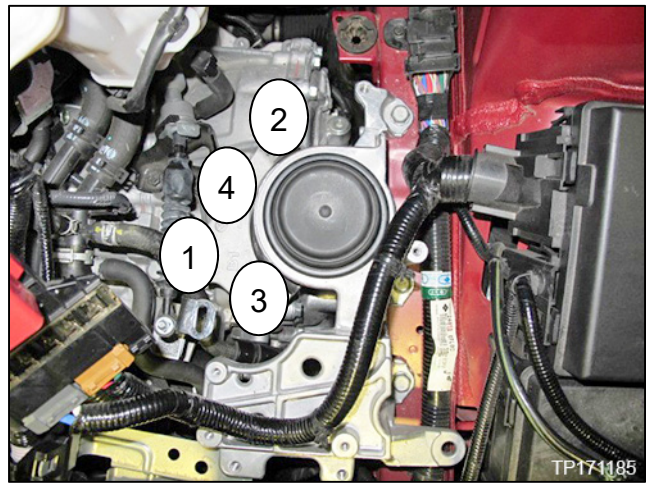

Figure 43

51. Align engine mounting insulator (LH) holes to frame.

- Hand start bolts 1, 2 and 3 on the top of the frame.

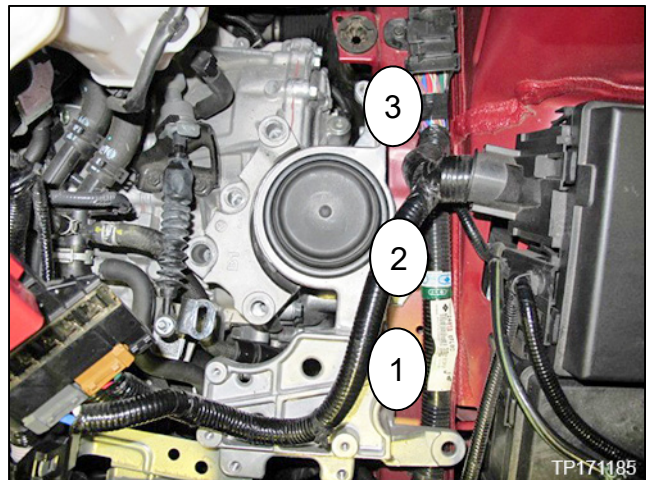

Figure 44

IMPORTANT: If the engine mounting insulator (LH) is not flush against the frame as described in the next step, step 52, then the engine mounting insulator (LH) will not operate as designed.

52. Secure bolts 4 and 5 just enough to ensure engine mounting insulator (LH) is flush against the frame of the vehicle.

53. Temporarily hand tighten all other bolts.

54. Prior to final torquing of the bolts in step 55 and step 56, lower the jack to allow the engine mounting insulator (LH) to sit flush on the frame and align with the bolt holes.

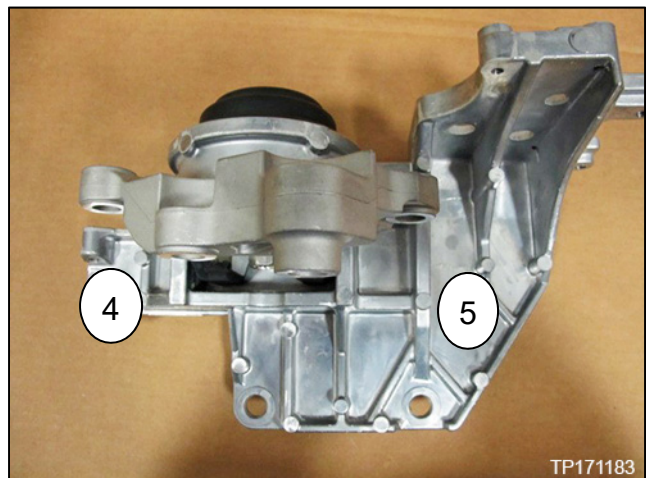

Figure 45

55. Torque the engine mounting insulator (LH).

- Torque Bolts 1, 2 and 3 in sequence to 80 N·m (8.2 kg-m, **59 ft-lb**).

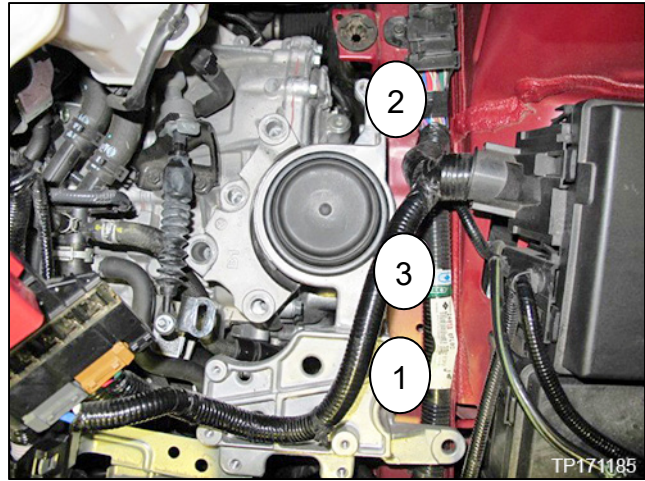

Figure 46

56. Torque Bolts 4 and 5 in sequence to 80 N·m (8.2 kg-m, **59 ft-lb**).

57. Raise vehicle on lift.

58. Hand start bolts 6 and 7.

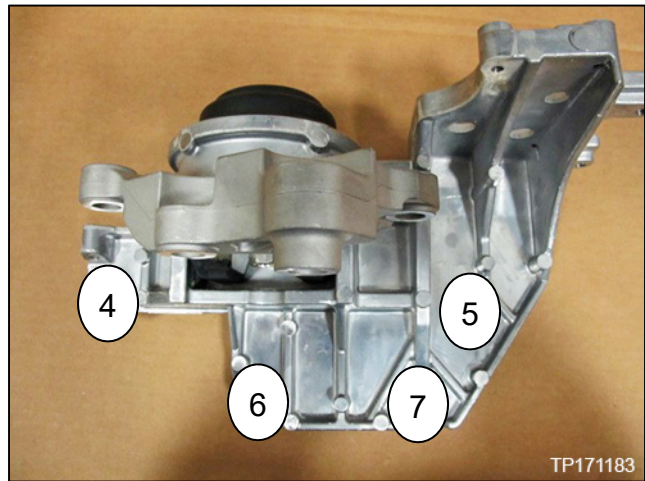

Figure 47

59. Using a click type flex-head reversible torque wrench and Nissan supplied “Torque Extension” J-52524, torque the engine mounting insulator (LH) bolts 6 and 7 on the inner lower driver side frame through the wheel well to 69 N·m (7.1 kg-m, **51 ft-lb**)*.

***NOTE:** The above torque values have already been adjusted to compensate for the length of the J-52524 tool when used with a torque wrench of 11 to 15 inches in length.

Make sure the torque extension stays in-line with the torque wrench as shown in Figure 49.

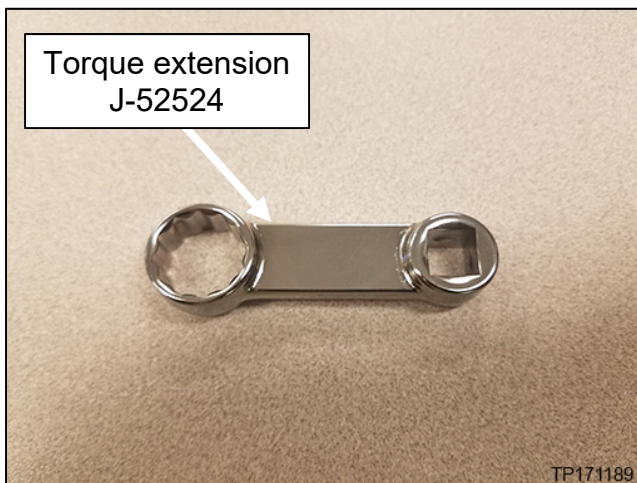

Figure 48

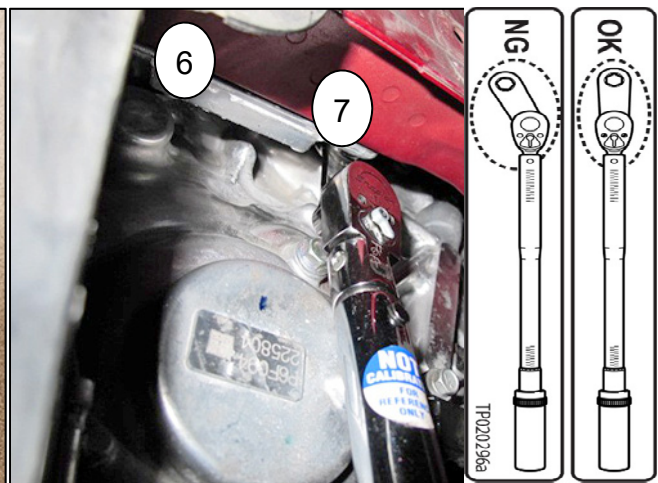

Figure 49

60. Install the engine side cover and attach the 6 clips.

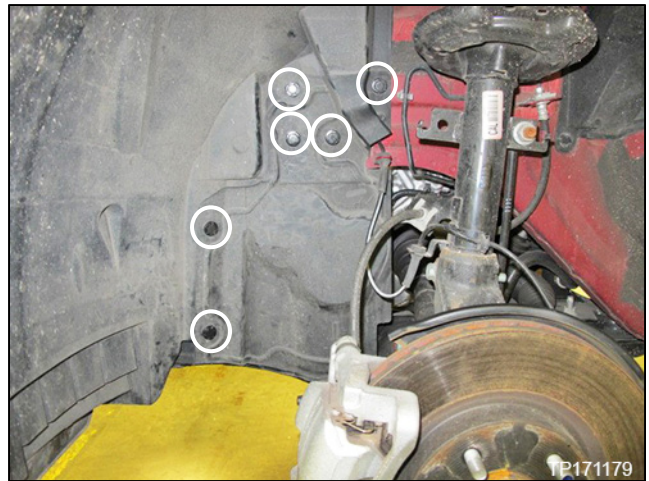

Figure 50

61. Install the left front tire and wheel assembly.

- Torque wheel nuts to 113 N·m (11.5 kg-m, **83 ft-lb**).

62. Lower vehicle from lift.

63. Install the air cleaner bracket.

- Torque air cleaner bracket bolt to 25 N·m (2.55 kg-m, **18 ft-lb**).

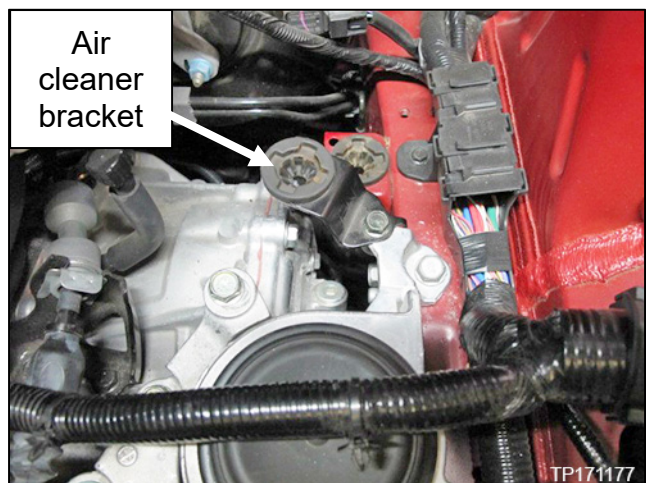

Figure 51

64. Install the air cleaner case.

- Torque air cleaner case bolt to 5.5 N·m (.56 kg-m, **49 in-lb**).
- Torque air duct clamp to 4.5 N·m (.46 kg-m, **40 in-lb**).

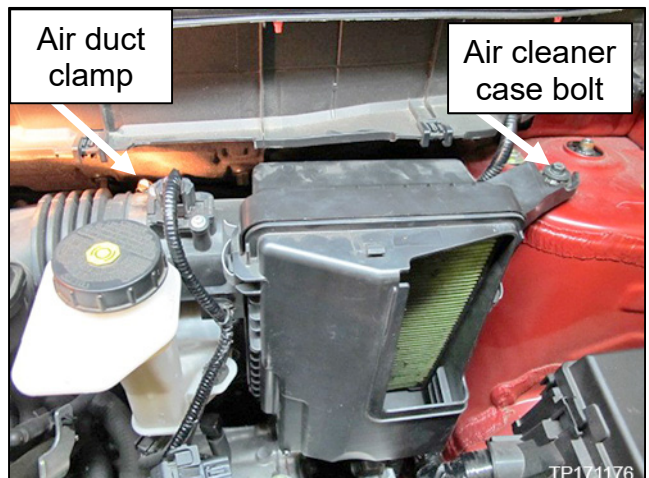

Figure 52

65. Attach the harness clips to the TCM bracket.

66. Connect the TCM harness connector to the TCM.

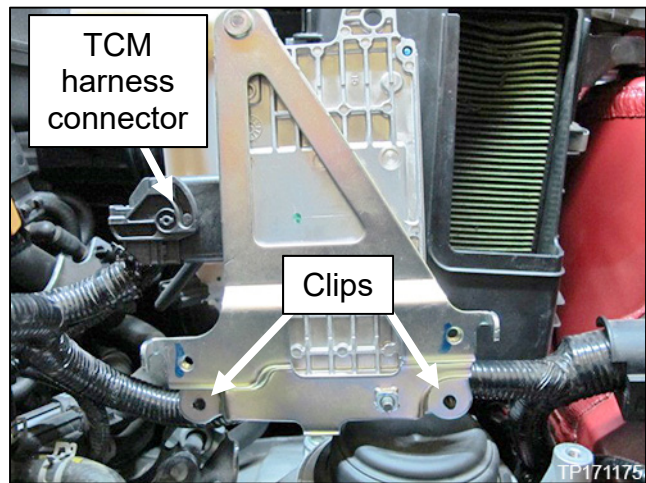

Figure 53

67. Ensure shift selector and Manual Lever are both in “Park”.

68. Install the control cable nut in its original position.

- Torque control cable nut to 13.5 N·m (1.37 kg-m, **10 ft-lb**).

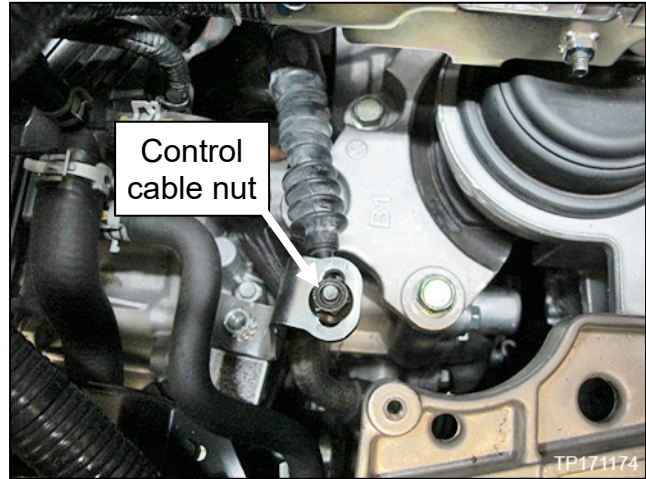

Figure 54

69. Install the 2 ECM harness bracket bolts.

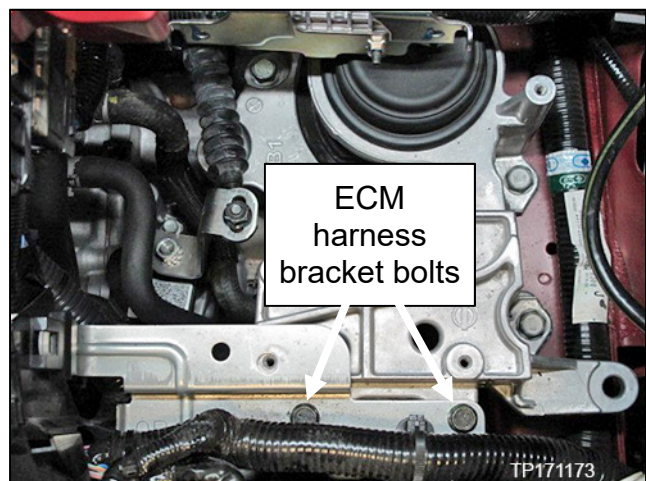

Figure 55

70. Install battery tray with ECM.

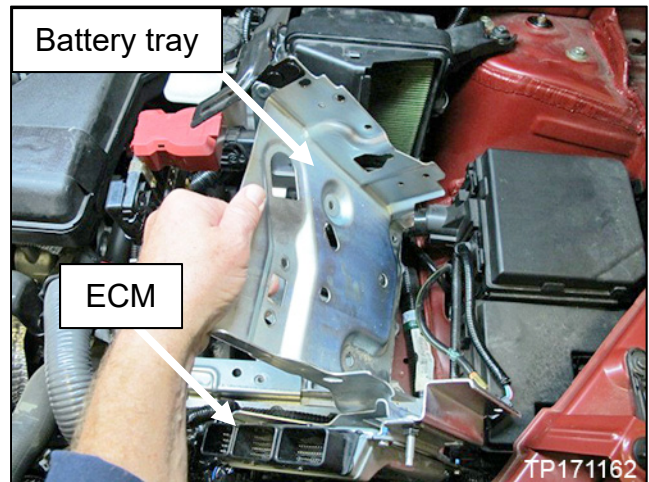

Figure 56

71. Attach tie strap clip to battery tray support.

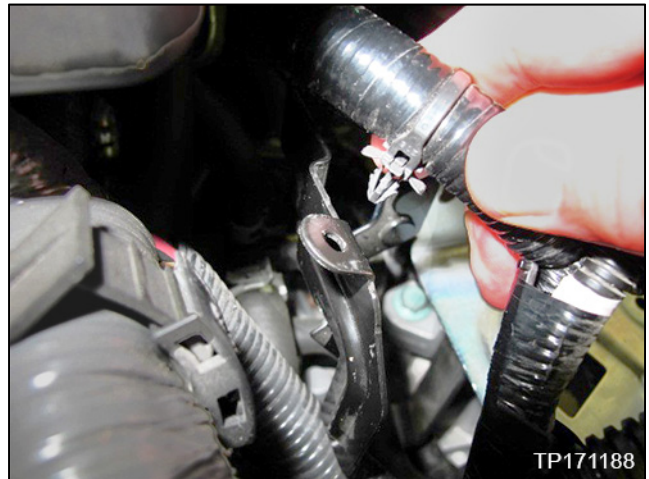

Figure 57

72. Install the 4 battery tray bolts.

- Torque bolts to 10 N·m (1.02 kg-m, 7 ft-lb).

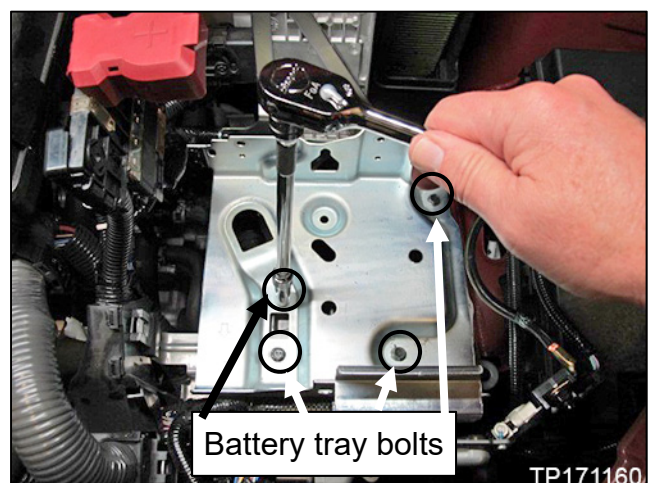

Figure 58

73. Install the TCM.

- Slide TCM bracket hooks over the edge of the battery tray and install the 2 TCM bracket bolts.
- Torque Bolts to 10N·m (1.02 kg-m, **7 ft-lb**).

CAUTION: Do not impact the TCM when removing or installing.

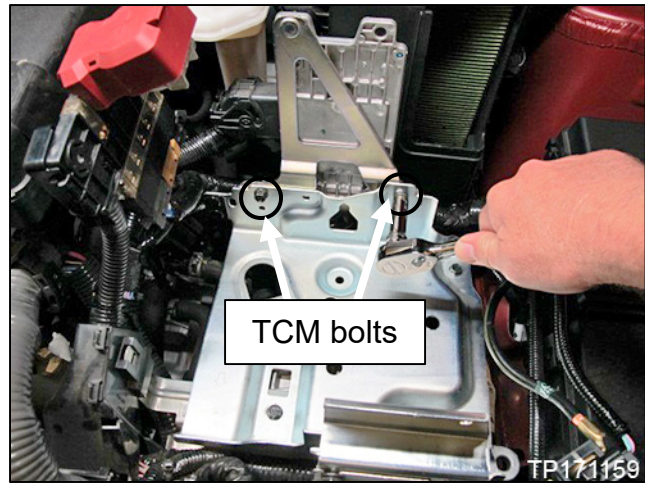

Figure 59

74. Connect the 3 ECM connectors to the ECM.

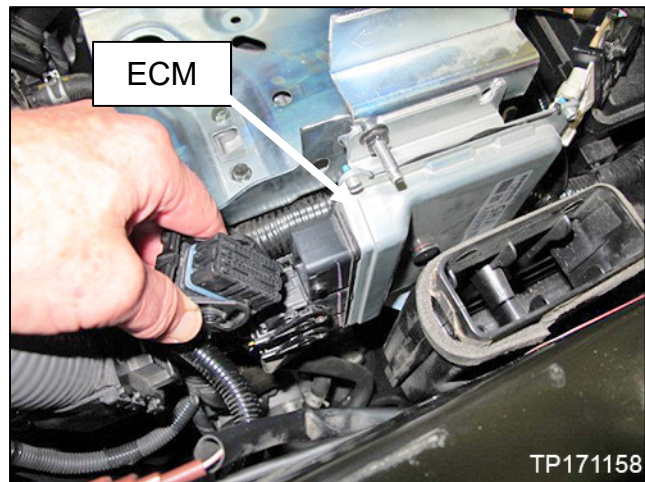

Figure 60

75. Install the air cleaner case duct and air duct assembly (fore).

- Slide the air duct assembly (fore) into the air duct.
- Using a suitable tool, install the 10 mm bolt and torque to 5.5 N·m (.56 kg-m, **49 in-lb**).
- Install the 2 mounting clips.
- Slide in the air cleaner case duct and snap into place.

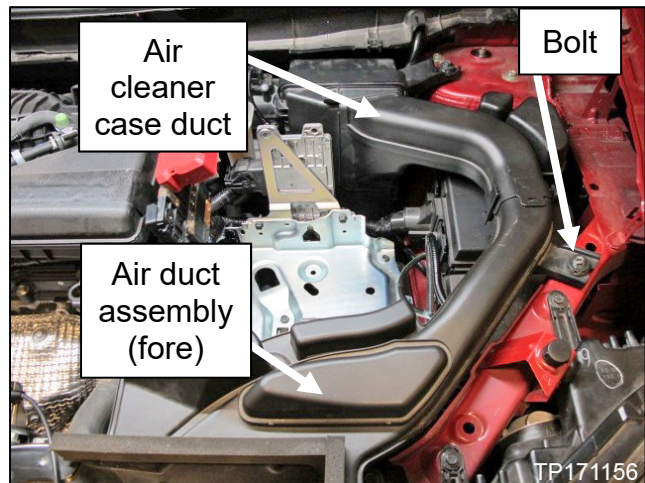

Figure 61

76. Install battery tray liner.
77. Install battery.
78. Install battery cover.
79. Install battery frame nuts.
80. Connect battery positive terminal.
81. Install cover on battery positive terminal.
82. Connect battery negative terminal.

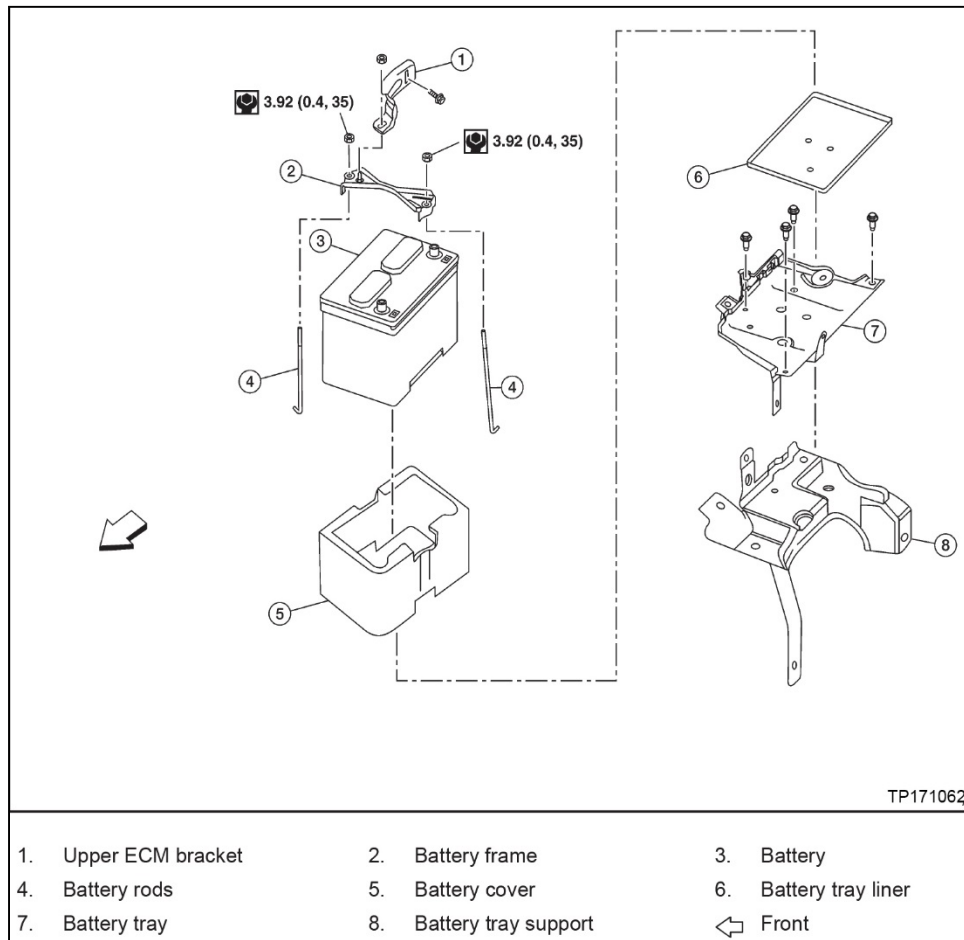

Figure 62

83. Reset/reinitialize systems as needed.

- Refer to the ESM section, PG – Power, Supply & Ground Elements for a listing of systems that require reset/initialization after reconnecting the 12V battery.
- Look in the PG section index for **ADDITIONAL SERVICE WHEN REMOVING BATTERY NEGATIVE TERMINAL.**
- This list often includes items such as audio, power windows, clock, etc.

84. Verify proper shift selector operation.

- Shift to all gear ranges and verify the actual position of the shift selector matches the position shown by the shift position indicator and manual lever on the transaxle.

PARTS INFORMATION

DESCRIPTION	PART NUMBER	QUANTITY
Engine mounting insulator (LH)	11220-4BA0B	1

CLAIMS INFORMATION

Submit a “CM” line claim using the following claims coding:

CAMPAIGN (“CM”) ID	DESCRIPTION	OP CODE	FRT
PC601	Engine Mounting Insulator (LH) Casting Mark Inspection (OK Condition)	PC6010	0.3 Hrs.
	Engine Mounting Insulator (LH) Casting Mark and Dent/Scratch Inspection (OK Condition)	PC6011	0.6 Hrs.
	Engine Mounting Insulator Casting Mark and Dent/Scratch Inspection, Remove and replace Engine Mounting Insulator (LH)	PC6012	1.4 Hrs.

