

**Brake Booster/Brake Master Cylinder**

Vehicle Type: **911 Carrera 2 (964)/911 Targa (964)/911 Speedster (964)**

Model Year: **As of 1990 up to 1994**

Subject: **Replacing brake booster during repairs**

Information: If the brake booster on the 911 Carrera 2/Targa/Speedster (964) needs to be replaced, the replacement brake booster will be a 911 (993) version.

During conversion, the brake master cylinder, mounting saddle and (push rod) joint screw must be replaced (⇒ *Figure 1*). The power steering pressure and return lines may also have to be replaced.

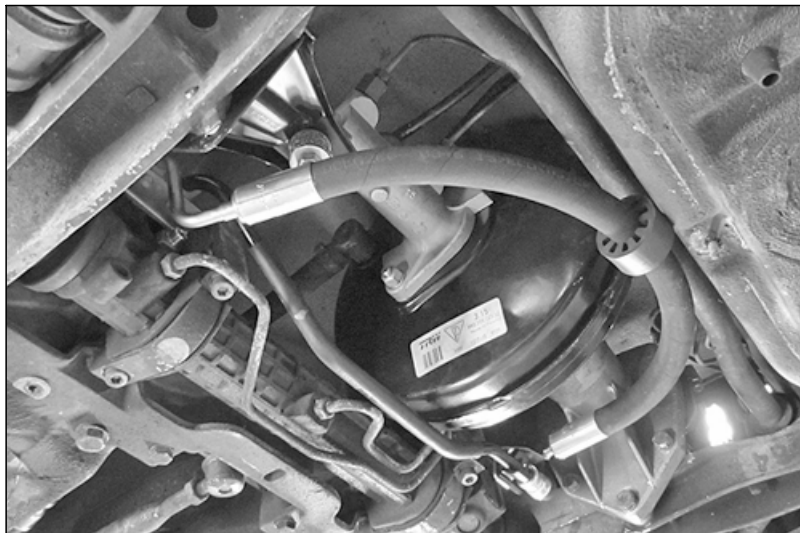

*Figure 1*

Parts Info: **PCG.355.182.01**

⇒ Brake booster, set

Parts list:

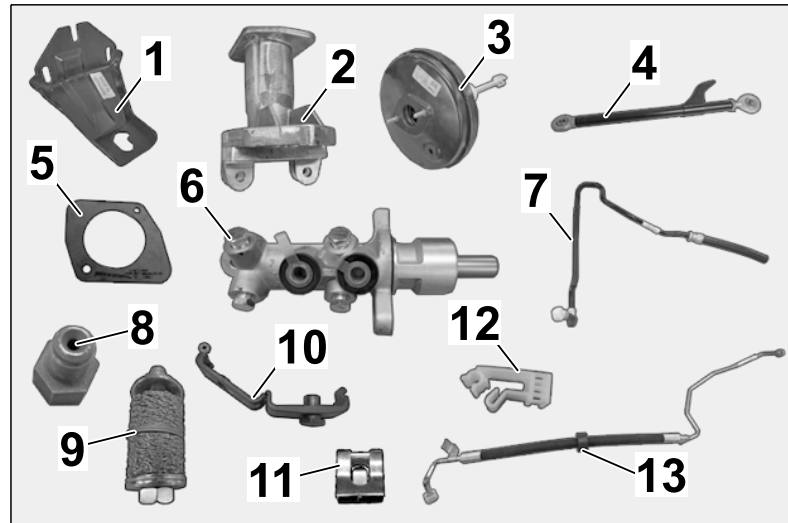

Figure 2

993.355.163.04	1 x	Brake master cylinder holder ⇒ Figure 2-1-
993.355.495.02	1 x	Mounting saddle ⇒ Figure 2-2-
993.355.023.10	1 x	Brake booster ⇒ Figure 2-3-
964.355.287.06	1 x	Push rod ⇒ Figure 2-4-
993.355.301.00	1 x	Seal ⇒ Figure 2-5-
993.355.910.00	1 x	Brake master cylinder ⇒ Figure 2-6-
993.347.449.01	1 x	Return line ⇒ Figure 2-7-
PCG.355.910.00	2 x	Brake line adapter ⇒ Figure 2-8-
— — —	1 x	Damping element comprising ⇒ Figure 2-9-: 1 x hexagon-head bolt, M8 x 55 (900.074.139.03) 2 x washer (900.151.008.02) 2 x washer (999.025.903.00) 2 x damping piece (964.355.485.00) 1 x lock nut (900.910.003.04) 1 x sleeve (964.355.483.00)
964.356.555.00	1 x	Clamp for pressure and return lines ⇒ Figure 2-10-
999.166.076.01	1 x	Safety clip, small ⇒ Figure 2-11-
999.507.396.40	1 x	Brake line holder ⇒ Figure 2-12-
993.347.448.11	1 x	Pressure line ⇒ Figure 2-13-
993.355.212.00	1 x	Seal between brake master cylinder and brake booster (not shown)
900.025.007.03	5 x	Washer (not shown)
999.084.425.02	2 x	Lock nut securing mounting saddle to brake booster
900.910.003.04	3 x	Lock nut
999.025.903.00	2 x	Washer (not shown)

964.356.557.00	1 x	Rubber mounting for pressure and return lines (not shown)
900.123.026.20	4 x	Sealing ring, 12 x 16 (not shown)
944.347.467.00	2 x	Cable clip (not shown)
999.512.346.00	1 x	Hose clamp for return hose (not shown)
999.166.077.02	1 x	Safety clips
993.555.545.00	1 x	Felt strips (not shown)
999.591.880.40	1 x	Brake line holder (not shown)
900.075.085.02	3 x	Hexagon-head bolt, M8 x 20 (not shown)
993.347.473.00	1 x	Line bracket (not shown)

Materials:

— — —	x	Brake fluid
— — —	x	Hydraulic oil

Tools:

- 9718** PIWIS Tester I "The Hammer"
- 9900** PIWIS Tester III "PT3G"
- VAS 6860** or Locally Available Brake Bleeder/Filler

- Work Procedure: 1 Preparatory work:
- 1.1 Extract brake fluid from reservoir.
  - 1.2 Remove wheels.
  - 1.3 Loosen push rod on the reversing lever.
    - 1.3.1 Pull bellows ⇒ *Figure 3-1*- off the cover ⇒ *Figure 3-2*- (⇒ *Figure 3-a*-).
- 3** – Steering gear

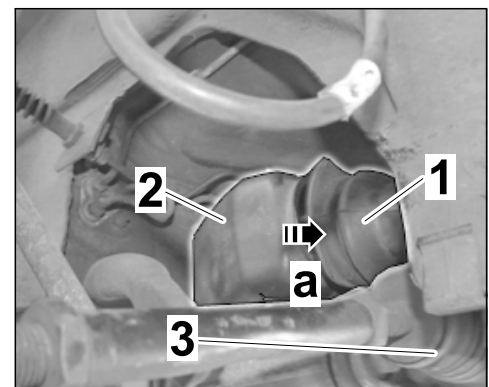

Figure 3

- 1.3.2 Remove safety clip ⇒ *Figure 4-1-*.  
Pull out bolt ⇒ *Figure 4-2-*.  
Guide the push rod ⇒ *Figure 4-3-*  
out of the reversing lever ⇒ *Figure 4-4-*.

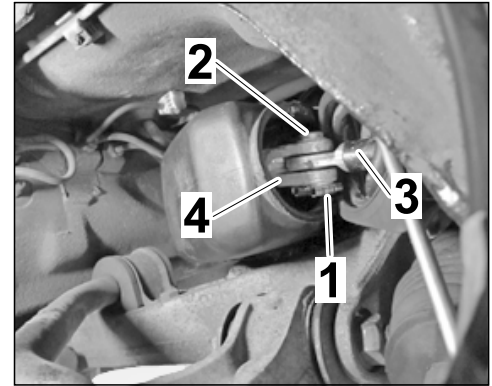

Figure 4

- 1.4 Remove underbody panelling ⇒ *Figure 5-1, 2, 3-*.

- 1 – Front axle  
2 – Center tunnel  
3 – Fuel pump

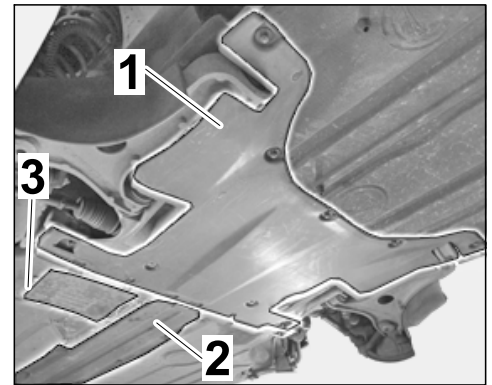

Figure 5

- 2 Remove brake master cylinder.

- 2.1 Remove brake master cylinder holder.  
2.1.1 Unscrew nut ⇒ *Figure 6-1-*.  
2.1.2 Unscrew hexagon-head bolts ⇒ *Figure 6-2-*.  
2.1.3 Remove brake master cylinder holder ⇒ *Figure 6-3-*.

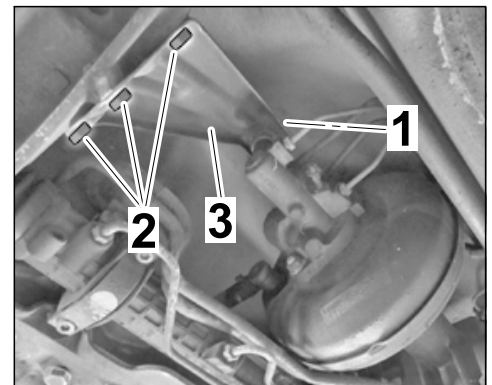

Figure 6

2.2 Unscrew cap screws ⇒ *Figure 7-1-* on the brake master cylinder.

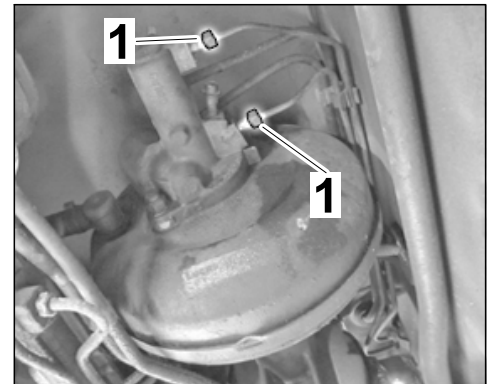
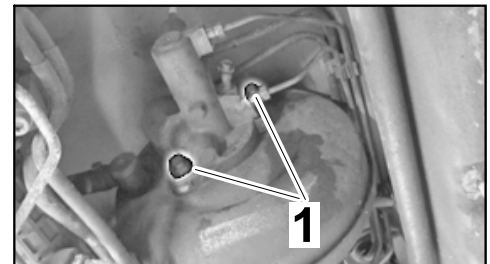

Figure 7

2.3 Unscrew hexagon nuts ⇒ *Figure 3-1-* from brake master cylinder.

Remove brake fluid feed lines ⇒ *Figure 8-2-* from brake master cylinder.



3 Remove mounting saddle.

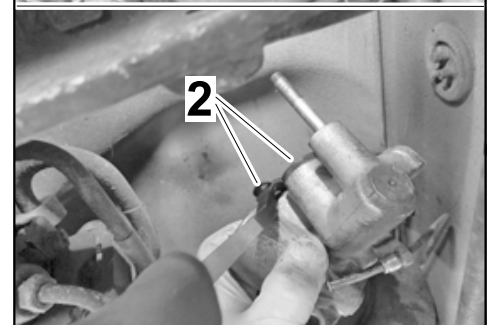

Figure 8

3.1 Loosen mounting saddle.

3.1.1 Pull vacuum hose ⇒ *Figure 9-1-* out of the brake booster ⇒ *Figure 9-a-*.

3.1.2 Unscrew hexagon-head bolts ⇒ *Figure 9-2-*.

3.2 Remove power steering pressure and return lines.

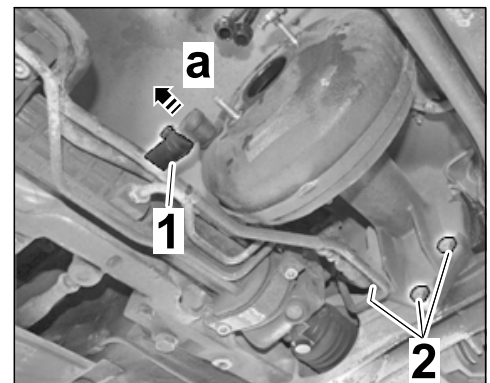

Figure 9

3.2.1 Loosen hose clamp ⇒ *Figure 10-3-*.

- 1 – Pressure line
- 2 – Return line

Pull off return line ⇒ *Figure 10-a-*.

Disconnect threaded connection ⇒ *Figure 10-4-* from pressure line.

Close off openings using suitable stoppers or use a collecting container.

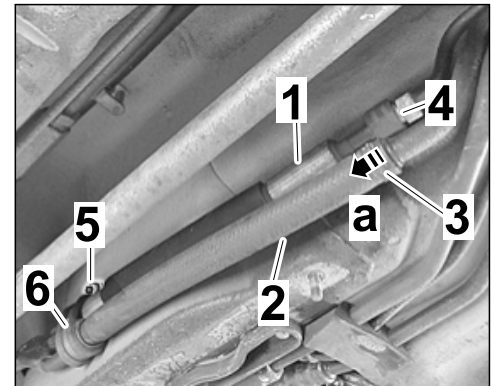

Figure 10

3.2.2 Unscrew hexagon nut ⇒ *Figure 10-5-* and remove holding clamp ⇒ *Figure 10-6-*.

3.2.3 Move the mounting saddle ⇒ *Figure 11-a-* so that the banjo bolts ⇒ *Figure 11-1-* on the steering gear are accessible.

Unscrew banjo bolts.

3.2.4 Unclip and remove pressure and return lines from the holder on the steering gear.

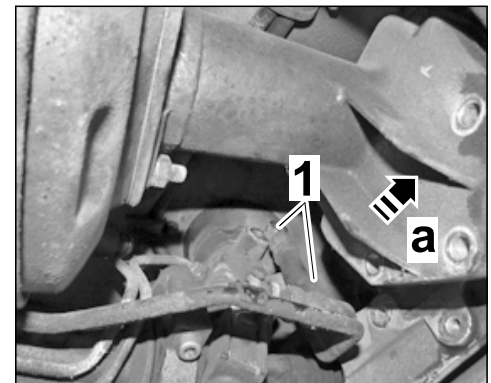

Figure 11

3.2.5 Swivel mounting saddle with brake booster downwards ⇒ *Figure 12-a-* and remove it ⇒ *Figure 12-b-*.

4 Assemble new mounting saddle.

4.1 Remove reversing lever from standard mounting saddle.

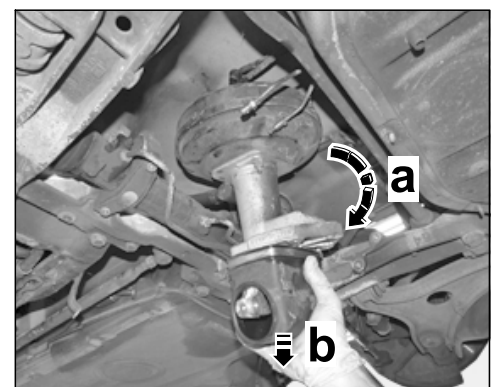

Figure 12

4.1.1 Unscrew hose clamp ⇒ *Figure 13-1-*.

Pull cover ⇒ *Figure 13-2-* off the mounting saddle ⇒ *Figure 13-3-*.

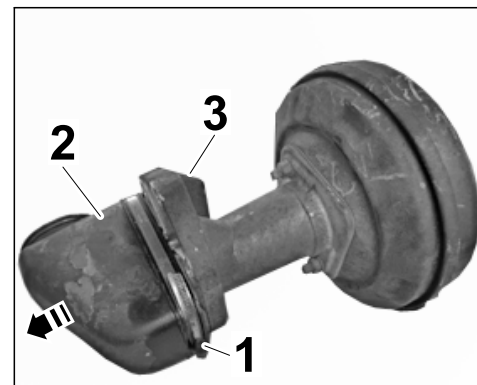

Figure 13

4.1.2 Remove safety clip ⇒ *Figure 14-1-* and pull out the bolt.

Remove safety clip ⇒ *Figure 14-2-* and pull out the bolt.

Remove reversing lever ⇒ *Figure 14-3-*.

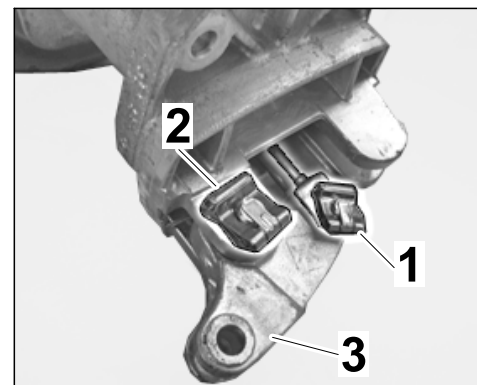

Figure 14

4.2 Position standard reversing lever ⇒ *Figure 15-1-* on the fork of the mounting saddle ⇒ *Figure 15-2-*.

Insert standard bolt ⇒ *Figure 15-3-* through the clevis bracket and reversing lever.

Fit new safety clip (999.166.077.02) ⇒ *Figure 15-4-*.

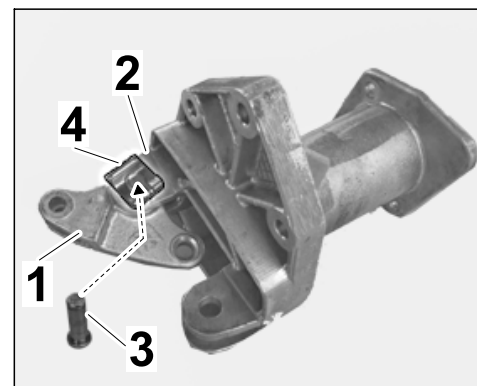

Figure 15

- 4.3 Join mounting saddle ⇒ *Figure 16-1-* and brake booster ⇒ *Figure 16-3-* using a new seal ⇒ *Figure 16-2-*.

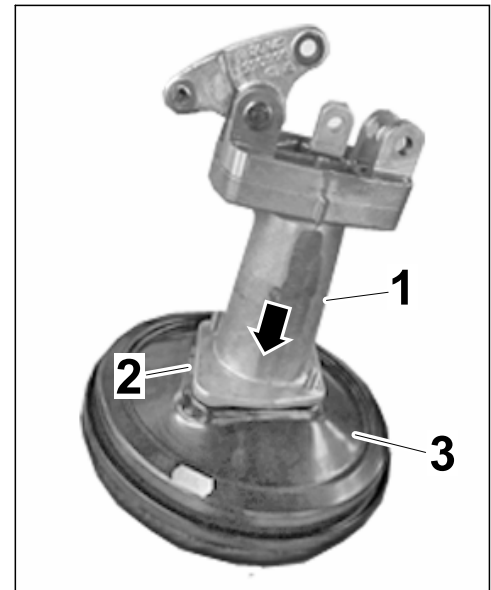

Figure 16

- 4.4 Tighten new hexagon nuts (999.084.425.02) ⇒ *Figure 17-2-*.

**Tightening torque 23 Nm (17 ftlb.)**

Use new washers (900.025.007.03).

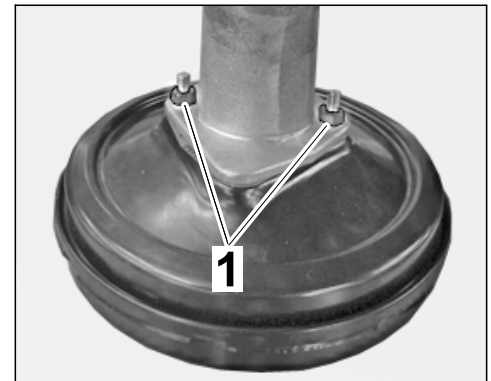

Figure 17

- 4.5 Insert standard bolt ⇒ *Figure 18-3-* through the clevis bracket on the push rod ⇒ *Figure 18-2-* and reversing lever ⇒ *Figure 18-1-*.

Fit new safety clip (999.166.076.01) ⇒ *Figure 18-4-*.

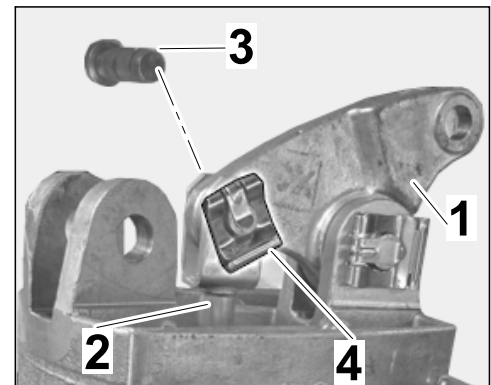

Figure 18



- 4.6 Affix felt tape in the marked area (widest circumference of the brake booster).
- 5 Remove tucker stud.



Figure 19

- 5.1 Pull brake line holder ⇒ *Figure 20-1*- off the tucker stud.
- 5.2 Cut tucker stud using side cutters.
- 5.3 Apply corrosion protection on bare surfaces.
- 6 Replace line bracket on the steering gear.

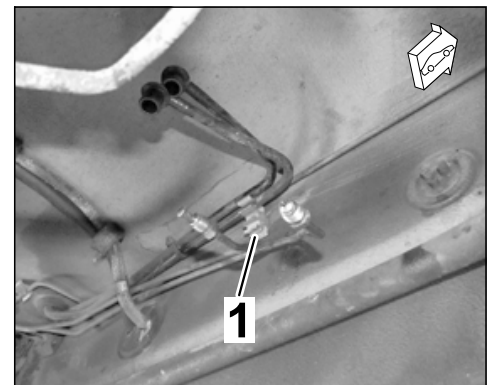

Figure 20

- 6.1 Unscrew hexagon socket head bolt ⇒ *Figure 21-1*-. Remove line bracket ⇒ *Figure 21-2*-.

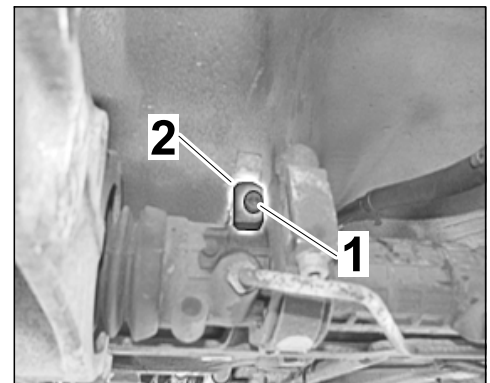

Figure 21

- 6.2 Remove cable clip ⇒ *Figure 22-1-* (944.347.467.00) from the old line bracket and fit it in the new line bracket ⇒ *Figure 22-2-*.

Secure new line bracket with a hexagon socket head bolt ⇒ *Figure 22-3-*.

- 7 Install mounting saddle.

- 7.1 Insert mounting saddle with brake booster ⇒ *Figure 23-1-* (⇒ *Figure 23-a-*) and swivel it up ⇒ *Figure 23-b-*.

- 7.2 Position mounting saddle ⇒ *Figure 24-1-* so that the connections on the steering gear ⇒ *Figure 24-2-* are accessible. Secure it to prevent it from falling down, if necessary.

- 7.3 Install power steering pressure and return lines.

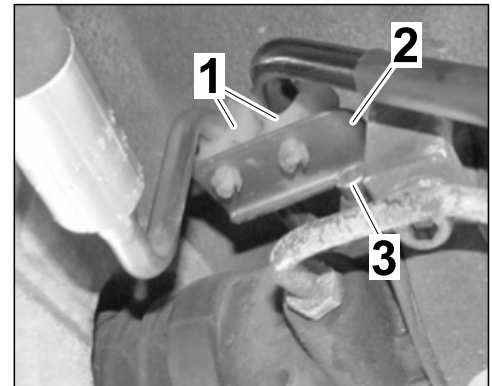

Figure 22

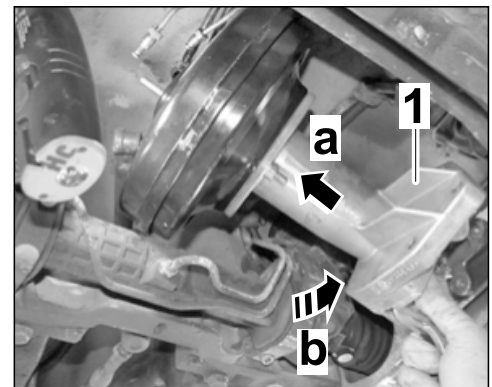

Figure 23

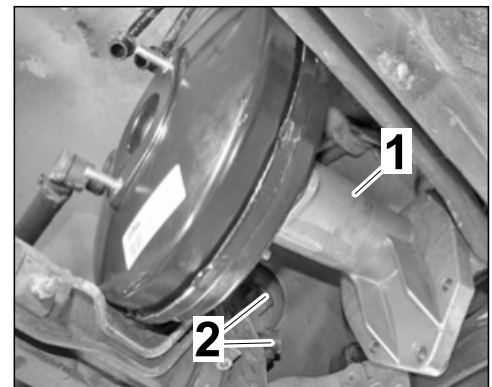

Figure 24

7.3.1 Clip cable clip (944.347.467.00) ⇒ *Figure 25-1*- into the holder on the pressure line.

7.3.2 Screw pressure and return lines onto the steering gear using banjo bolts ⇒ *Figure 25-2*- and new sealing rings (900.123.026.00). Only tighten banjo bolts slightly.

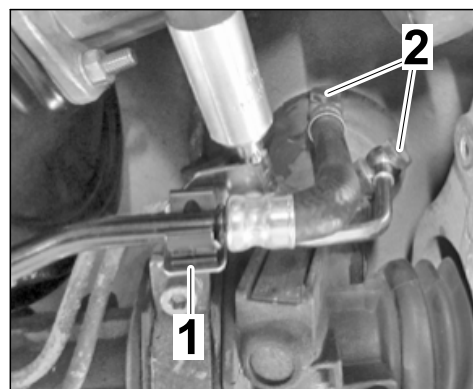

Figure 25

7.3.3 Clip pressure and return lines ⇒ *Figure 26-1*- into the new holder ⇒ *Figure 26-2*-.

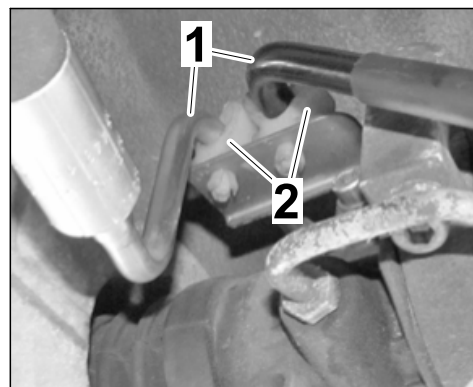

Figure 26

7.3.4 Screw pressure line ⇒ *Figure 27-1*- together in the centre tunnel. **Tightening torque 25 Nm (19 ftlb.)**

Push on return line ⇒ *Figure 27-2*- and secure with a new hose clamp (999.512.346.00).

7.3.5 Secure pressure and return lines to the threaded bolt using a new rubber mounting (964.356.557.00) and a new clamp (964.356.555.00 ⇒ *Figure 27-3*-.

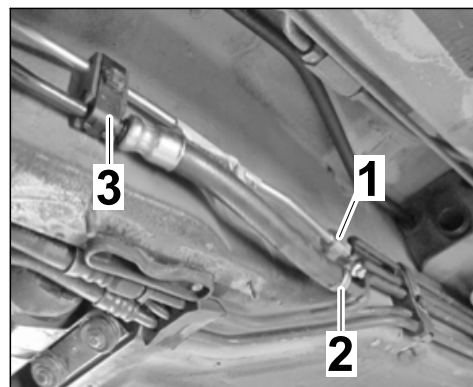
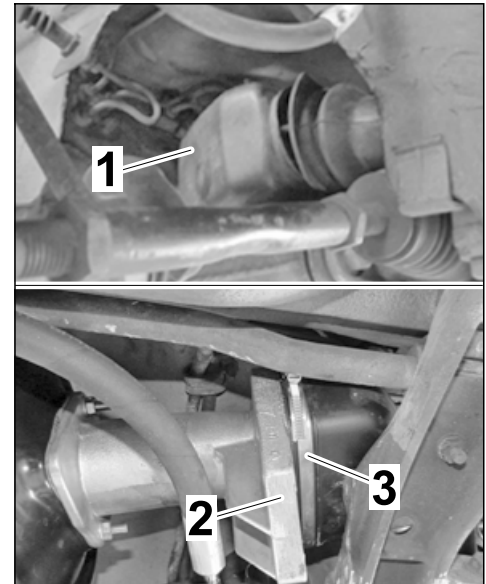

Figure 27

7.3.6 Tighten banjo bolts on the steering gear. **Tightening torque 20 Nm (15 ftlb.)**

- 7.4 Fit cover ⇒ *Figure 28-1-* over the wheel arch access point on the mounting saddle ⇒ *Figure 28-2-*.

Tighten hose clamp ⇒ *Figure 28-3-*.



*Figure 28*

- 7.5 Secure mounting saddle ⇒ *Figure 29-1-* to the front axle housing ⇒ *Figure 29-2-*.  
**Tightening torque 23 Nm (17 ftlb.)**

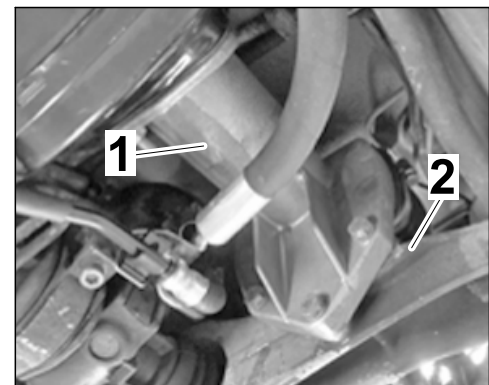

*Figure 29*

- 7.6 Replace push rod.
- 7.6.1 Disengage tension spring ⇒ *Figure 30-1-*.
  - 7.6.2 Remove safety clip ⇒ *Figure 30-2-*.
  - 7.6.3 Loosen lock nut ⇒ *Figure 30-3-* on the brake pushrod.
  - 7.6.4 Remove joint screw ⇒ *Figure 30-4-* from brake pedal.
  - 7.6.5 Pull out push rod ⇒ *Figure 30-5-*.
  - 7.6.6 The new push rod is installed in reverse order to removal.

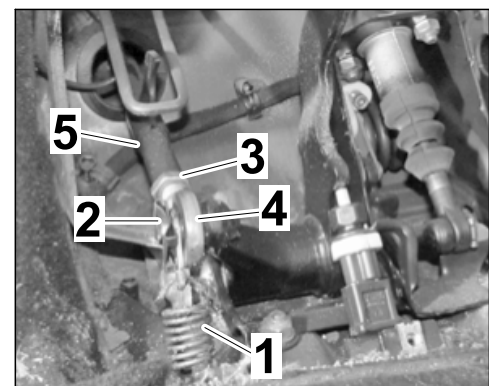

*Figure 30*

- 7.7 Secure push rod on the reversing lever.
  - 7.7.1 Insert bolt  $\Rightarrow$  *Figure 31-2-* through the swivel head on the reversing lever  $\Rightarrow$  *Figure 31-4-* and push rod  $\Rightarrow$  *Figure 31-3-*.
  - 7.7.2 Tighten safety clip  $\Rightarrow$  *Figure 31-1-*.

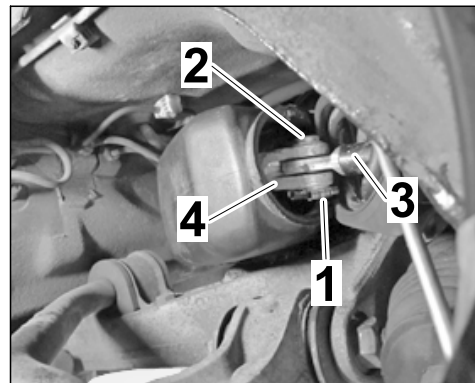

Figure 31

- 7.7.3 Fit bellows  $\Rightarrow$  *Figure 32-1-* on the cover  $\Rightarrow$  *Figure 32-2-*.

- 7.8 Fit vacuum hose into the brake booster.

8 Install brake master cylinder.

- 8.1 Assemble brake master cylinder.

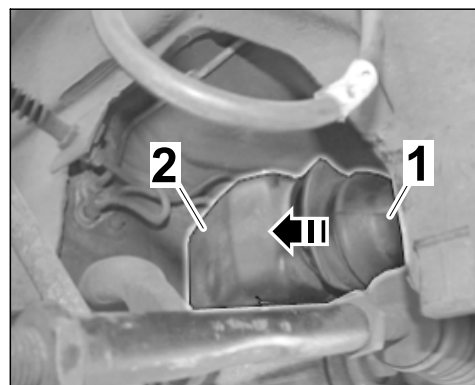

Figure 32

- 8.1.1 Unscrew and remove screw plugs  $\Rightarrow$  *Figure 33-2-*.

Screw brake line adapter  $\Rightarrow$  *Figure 33-3-* securely into the brake master cylinder.

**Tightening torque 12 Nm (9 ftlb.) +4 Nm (+3 ftlb.)**

- 8.1.2 Tighten screw plugs  $\Rightarrow$  *Figure 33-1-*.

**Tightening torque 12 Nm (9 ftlb.) +4 Nm (+3 ftlb.)**

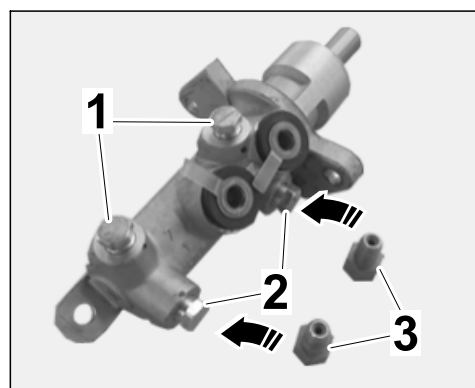

Figure 33

- 8.2 Insert brake master cylinder and secure with new washers ⇒ *Figure 34 -1-* and M8 lock nuts ⇒ *Figure 34 -2-*.

**Tightening torque 23 Nm (17 ftlb.)**

- 8.3 Carefully bend the brake line until the cap screw in the brake line adapter can be screwed in by hand. Tighten cap screw.

**Tightening torque 13 Nm (9.5 ftlb.)  
+/-1 Nm (+/-0.5 ftlb.)**

- 8.4 Fit brake fluid feed lines into the brake master cylinder.

- 8.5 Install brake master cylinder holder.

- 8.5.1 Screw brake master cylinder holder ⇒ *Figure 35 -1-* onto the front axle housing using new washers (900.025.007.03) and new hexagon-head bolts (N 010.240.11) ⇒ *Figure 35-2-*. Only tighten hexagon-head bolts slightly.

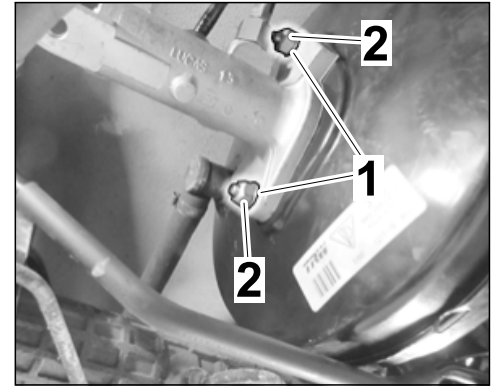

*Figure 34*

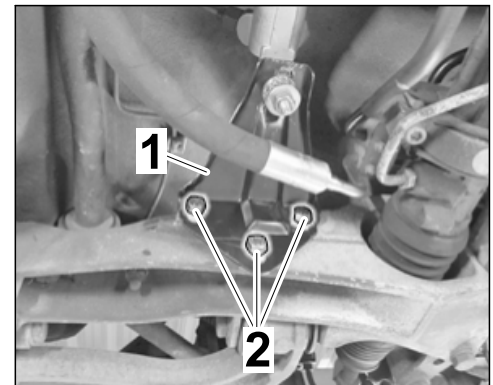

*Figure 35*

- 8.5.2 Connect brake master cylinder holder and brake master cylinder as shown.

- 1 – Hexagon-head bolt, M8 x 55 (900.074.139.03)
- 2 – Washer (900.151.008.02)
- 3 – Washer (999.025.903.00)
- 4 – Damping piece (964.355.485.00)
- 5 – Lock nut (900.910.003.04)
- 6 – Sleeve (964.355.483.00)

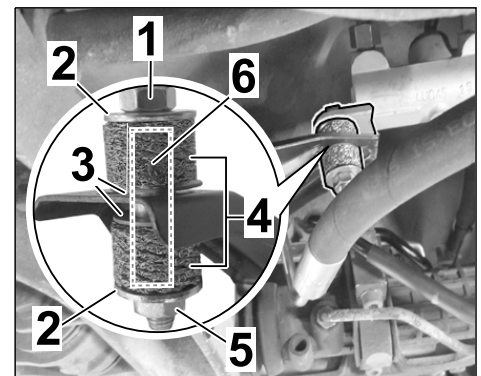

*Figure 36*

- 8.5.3 Secure brake master cylinder holder to the front axle housing.  
**Tightening torque 23 Nm (17 ftlb.)**

- 8.6 Secure brake lines with two holders.

- 8.6.1 Secure brake lines in the area where the tucker stud was removed ⇒ *Figure 37 -arrow-* using a holder (999.591.880.40) ⇒ *Figure 37 -1-*.

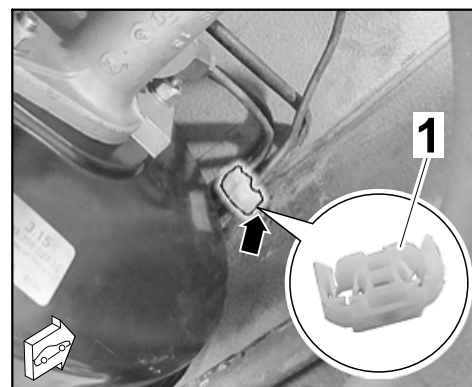

Figure 37

- 8.6.2 Secure brake lines in the mounting saddle area ⇒ *Figure 38-2-* using a holder (999.507.396.40) ⇒ *Figure 38-1-*.

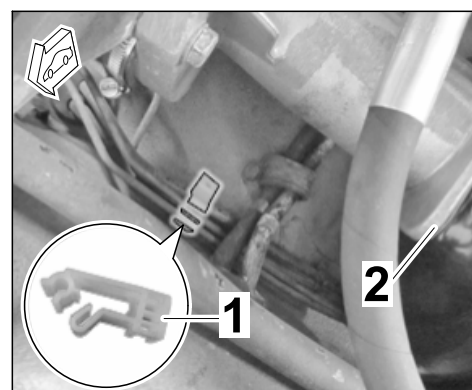

Figure 38

9 Concluding work:

- 9.1 Bleed the brake system.
- 9.2 Fit wheels.  
**Tightening torque 130 Nm (96 ftlb.)**
- 9.3 Bleed the steering and check for leaks.

- 9.4 Install underbody panelling ⇒ *Figure 39-1, 2, 3-*.

- 1 – Front axle
- 2 – Center tunnel
- 3 – Fuel pump

- 9.5 Check the brake pushrod (brake pedal) and brake light switch setting and make adjustments if necessary. ⇒ PIWIS Information system/Document title 4602

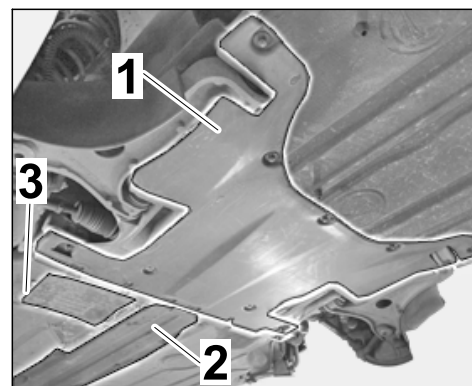

Figure 39

- 47013100: Converting brake system Labor time: **332 TU**  
Includes: Removing and installing front and rear wheels, underbody covers (3 x), brake master cylinder, mounting saddle with brake booster, and push rod, replacing pressure and return lines on steering gear, bleeding the steering system  
Without: Bleeding the brake system
- 47010750: Bleeding the brake system Labor time: **110 TU**  
Without: Removing and installing wheels

**Important Notice:** Technical Bulletins issued by Porsche Cars North America, Inc. are intended only for use by professional automotive technicians who have attended Porsche service training courses. They are written to inform those technicians of conditions that may occur on some Porsche vehicles, or to provide information that could assist in the proper servicing of a vehicle. Porsche special tools may be necessary in order to perform certain operations identified in these bulletins. Use of tools and procedures other than those Porsche recommends in these bulletins may be detrimental to the safe operation of your vehicle, and may endanger the people working on it. Properly trained Porsche technicians have the equipment, tools, safety instructions, and know-how to do the job properly and safely. Part numbers listed in these bulletins are for reference only. The work procedures updated electronically in the Porsche PIWIS diagnostic and testing device take precedence and, in the event of a discrepancy, the work procedures in the PIWIS Tester are the ones that must be followed.

© 2018 Porsche Cars North America, Inc.