



NUMBER: 08-107-14

GROUP: Electrical

DATE: December 06, 2014

This bulletin is supplied as technical information only and is not an authorization for repair. No part of this publication may be reproduced, stored in a retrieval system, or transmitted, in any form or by any means, electronic, mechanical, photocopying, or otherwise, without written permission of Chrysler Group LLC.

SUBJECT:

Radio Loss Of Audio Signal Or Static Interference On FM Stations

OVERVIEW:

This bulletin involves verifying the static concern on FM radio station frequencies and if applicable, replacing the inner combination tail stop backup lamp.

MODELS:

2015 (LA) Dodge Challenger

NOTE: This bulletin applies to vehicles built on or before September 25, 2014 (MDH 0925XX).

SYMPTOM/CONDITION:

The customer may describe a loss of audio signal or static interference on FM radio stations.

DIAGNOSIS:

If the customer describes the symptom, perform the Repair Procedure.

PARTS REQUIRED:

| Qty. | Part No. | Description |
|--------|------------|-------------------------------|
| 1 (AR) | 68195784AE | LAMP, Tail Stop Backup, Inner |

REPAIR PROCEDURE:

1. Turn the engine on.
2. Turn the air conditioning on, with the blower on the highest speed and the temperature on the lowest temperature setting.
3. Allow the vehicle to run for 10 minutes.
4. Turn the radio to the lowest receivable FM station frequency band (Ex. 88.7 FM) and verify an audible station is present.
5. Turn the park lamps on (NOT the headlamps).
6. Listen for noise (radio static) or no audio output (audio is muted) while cycling the park lamps off/on to determine if the noise or audio level changes.
 - a. If noise or audio level changes while cycling the park lamps off/on, proceed to [Step #10](#).
 - b. If the sound is clear and unchanged while cycling the park lamps off/on, continue to [Step #7](#).

7. Turn the headlamp switch to the off position.
8. Using the radio SCAN button, tune to the next receivable FM station frequency band.
9. Repeat [Step #5](#) and [Step #6](#) until you reach the end of the FM station frequency band (Ex. 107.9 FM).
 - a. If the sound is clear and unchanged while cycling the park lamps off/on throughout the entire FM frequency band, this Bulletin does not apply. Further diagnosis is required.
 - b. If radio reception is poor (radio static) or no audio output (audio is muted) with the parking lamps on continue to [Step #10](#).
10. Disconnect the rear inner combination tail stop backup lamp by removing fuse 6 from the power distribution center located in the trunk, as shown in ([Fig. 1](#)).

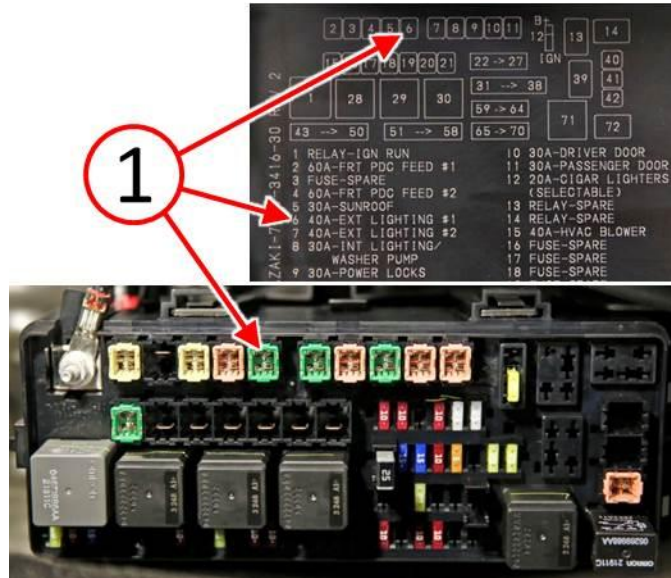

Fig. 1 Fuse 6

1 - Fuse 6

11. With the radio tuned to an FM station frequency band experiencing static, turn the park lamps on (NOT the headlamps).
12. With fuse 6 removed, listen for noise (radio static) or no audio output (audio is muted). Cycle the park lamps off/on to determine if the noise or audio level changes.
 - a. If the sound remains clear and unchanged while cycling the park lamps off/on, continue to [Step #13](#).
 - b. If noise or audio level changes while cycling the park lamps off/on, this Bulletin does not apply. Install fuse 6 and clear any diagnostic trouble codes that may have set due to fuse 6 being disconnected. Further diagnosis is required.
13. Replace the inner combination tail stop backup lamp. Refer to the detailed service procedures available in DealerCONNECT> TechCONNECT under: Service Info> 08 - Electrical> 8L - Lamps and Lighting> Lamps/Lighting - Exterior> LAMP, Rear inner combination> Removal/Installation.

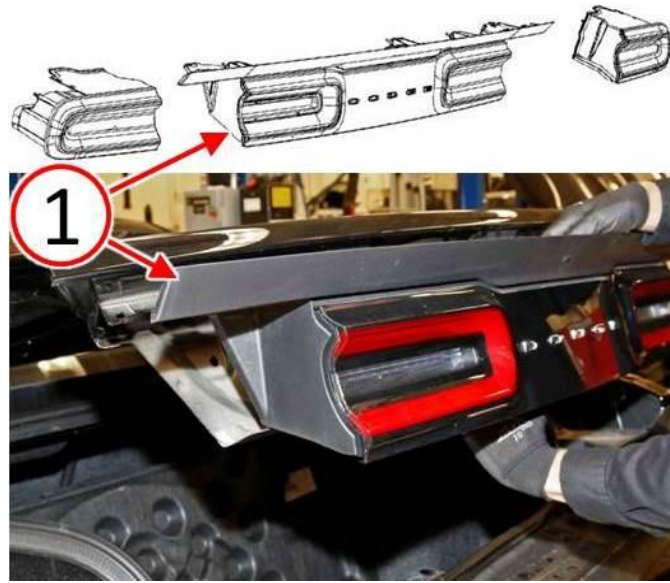

Fig. 2 Replace Inner Combination Tail Stop Backup Lamp

1 - Inner Combination Tail Stop Backup Lamp

14. Install fuse 6 and clear any diagnostic trouble codes that may have set due to fuse 6 being disconnected.

POLICY:

Reimbursable within the provisions of the warranty.

TIME ALLOWANCE:

| Labor Operation No: | Description | Skill Category | Amount |
|---------------------|--|---------------------------------|----------|
| 08-50-89-92 | Test Radio Reception Only (0 - Low Skilled) | 6 - Electrical and Body Systems | 0.4 Hrs. |
| 08-50-89-93 | Test Radio Reception And Replace Tail Stop Backup Lamp (0 - Low Skilled) | 6 - Electrical and Body Systems | 0.6 Hrs. |

FAILURE CODE:

| | |
|----|----------------|
| ZZ | Service Action |
|----|----------------|