

FLA COE  
FLB COE  
> FLD Conventional  
Business Class

FLC 112 Conventional  
> Century Class Conventional  
Argosy COE  
Cargo

> Columbia  
> Coronado  
> Business Class M2  
> Cascadia

**Freightliner  
Service Bulletin**

**Description of Revisions:** *This replaces the version dated February 2009; two more crossover part numbers are added to [Table 2](#).*

## General Information

As part of the changes made for early production EPA07 engines, the transmission oil cooler was moved into the radiator, and transmission oil cooler lines equipped with Gates Quick-Detach (QLD) connectors were fitted.

In May 2007, on all vehicles equipped with Eaton Autoshift, Eaton Ultrashift, or heavy-duty manual transmissions, the QLD connectors were removed from production and replaced by JIC fittings; see [Table 1](#).

In October 2007, on all vehicles equipped with Allison transmissions, the QLD connectors were removed from production and replaced by Jiffy-tite fittings. Replacement radiators should be ordered according to the vehicle specification as shown in [Table 1](#). For radiator removal and installation (for replacement) instructions, see the appropriate workshop manual.

Production Use of Gates QLD Connectors			
Dates	Transmissions	Early Production	Connector Now Used
01/07 into 05/07	Eaton Autoshift, Eaton Ultrashift, or Heavy-Duty Manual	QLD	JIC
01/07 into 10/07	Allison Automatics	QLD	Jiffy-tite

**Table 1, Production Use of Gates QLD Connectors**

**IMPORTANT:** Only Jiffy-tite- and JIC-equipped replacement radiators are available from the PDCs. There are no QLD-equipped replacement radiators available.

## Adapting Jiffy-tite Replacement Radiators to QLD-Equipped Vehicles

On vehicles equipped with Allison automatic transmissions, Jiffy-tite connectors replace the QLDs. On them, the transmission oil cooler lines must be replaced when the radiator is replaced. See [Table 2](#) for part crossover information.

QLD to Jiffy-tite Transmission Oil Cooler Line Crossover Part Numbers	
QLD-Equipped (Discontinued)	Jiffy-tite Replacement
GT 1200QLD058	GT 1200JT058
GT 1245QLD060	GT 1245JT072
GT 1245QLD064	GT 1245JT064
GT 1245QLD072	GT 1245JT072
GT 1245QLD075	GT 1245JT074
GT 1245QLD076	GT 1245JT076
GT 1245QLD080	GT 1245JT080
GT 1290QLD071	GT 1290JT071
GT 1290QLD073	GT 1290JT073
GT 1290QLD075	GT 1290JT088
GT 1290QLD078	GT 1290JT078

## Freightliner Service Bulletin

FLA COE  
FLB COE  
> FLD Conventional  
Business Class

FLC 112 Conventional  
> Century Class Conventional  
Argosy COE  
Cargo

> Columbia  
> Coronado  
> Business Class M2  
> Cascadia

QLD to Jiffy-tite Transmission Oil Cooler Line Crossover Part Numbers	
QLD-Equipped (Discontinued)	Jiffy-tite Replacement
GT 1290QLD083	GT 1290JT083
GT 1290QLD087	GT 1290JT088
GT 1290QLD091	GT 1290JT092
GT 1200QLD070	GT 1200JT069
GT 1200QLD072	GT 1200JT073
GT 1200QLD075	GT 1200JT075
GT 1290QLD080	GT 1290JT080
GT 1200QLD077	GT 1200JT077
GT 1290QLD095	GT 1290JT095

**Table 2, QLD to Jiffy-tite Transmission Oil Cooler Line Crossover Part Numbers**

## Connecting

To connect the Jiffy-tite-equipped line, pull back on the socket collar, insert the line into the port connector, then release the collar.

## Adapting QLD-Equipped Transmission Oil Cooler Lines to a JIC-Equipped Radiator

To replace a radiator having QLD connectors with a JIC-equipped radiator, order two adapters, p/n GT 7213 0003 (see [Fig. 1](#)), and install them on the radiator so that the existing QLD lines can attach. Tighten them 53 lbf·ft (72 N·m).

The adapter connectors are installed only at the radiator; the original QLD transmission oil cooler lines continue to be used.

## Warranty

Normal warranty applies.

FLA COE  
FLB COE  
> FLD Conventional  
Business Class

FLC 112 Conventional  
> Century Class Conventional  
Argosy COE  
Cargo

> Columbia  
> Coronado  
> Business Class M2  
> Cascadia

**Freightliner  
Service Bulletin**

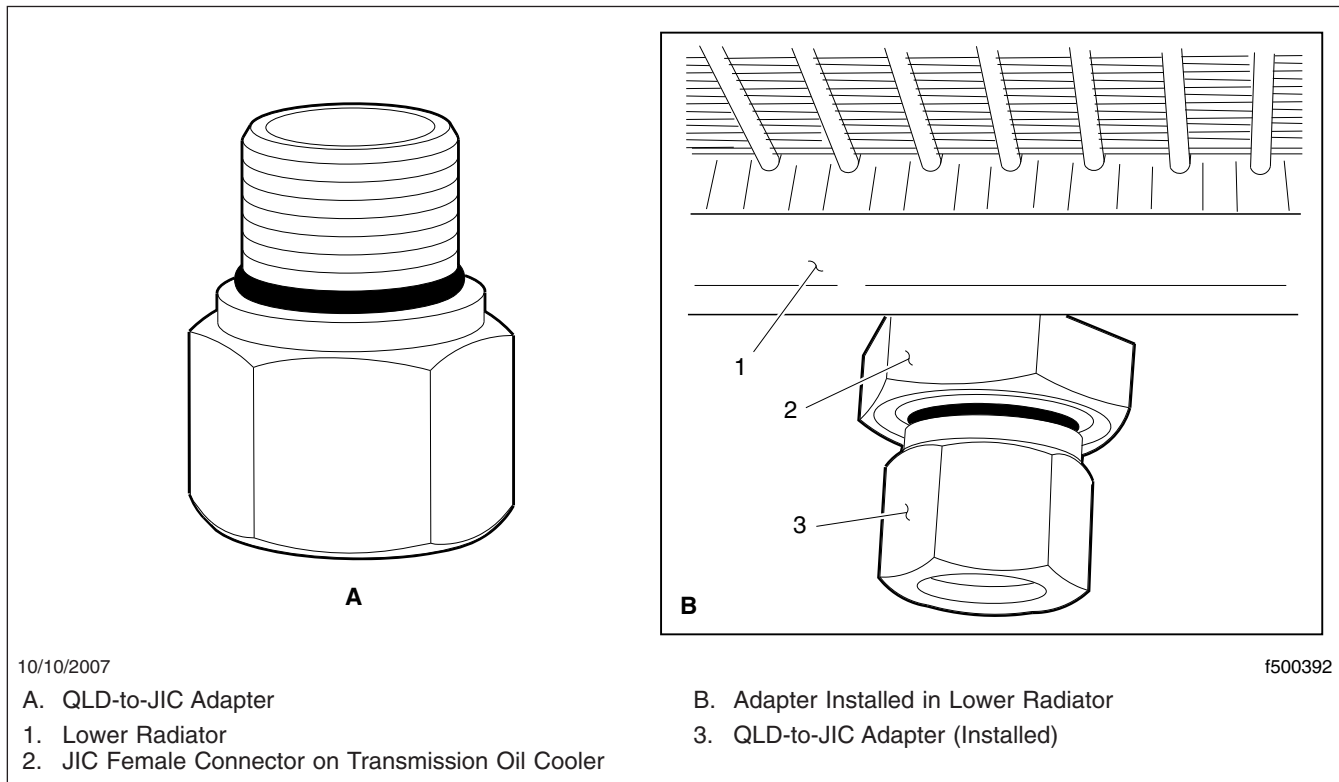

**Fig. 1, QLD-to-JIC Adapter, p/n GT 7213 0003**