

JTB00457NAS1

TECHNICAL BULLETIN

23 MAY 2018



© Jaguar Land Rover North America, LLC

NOTE: The information in Technical Bulletins is intended for use by trained, professional Technicians with the knowledge, tools, and equipment required to do the job properly and safely. It informs these Technicians of conditions that may occur on some vehicles, or provides information that could assist in proper vehicle service. The procedures should not be performed by 'do-it-yourselfers'. If you are not a Retailer, do not assume that a condition described affects your vehicle. Contact an authorized Jaguar service facility to determine whether this bulletin applies to a specific vehicle.

INFORMATION**SECTION:**

303-04E: Fuel Charging and Controls - Turbocharger

SUBJECT/CONCERN:

Whine/Whistle Noise From The Turbocharger

AFFECTED VEHICLE RANGE:

MODEL:	MODEL YEAR:	VIN:	ASSEMBLY PLANT:	APPLICABILITY:
F-PACE (X761)	2017	046303-097602	Solihull	INGENIUM I4 2.0L Diesel

MARKETS:

NORTH AMERICA

CONDITION SUMMARY:**SITUATION:**

A whine or whistle noise from the exhaust system may be evident when the engine is between 1,700-2,000 Revolutions Per Minute (RPM). This noise may also be heard inside the passenger compartment when driving at low speeds up to 64 km/h (40 mph).

CAUSE:

This may be caused by noise from the turbocharger being transmitted via the exhaust system mounting rubber.

NOTE:

This issue affects only vehicles with an engine serial number up to and including 151001W0302. Use the Jaguar Land Rover (JLR) Claims Submission System to obtain the engine serial number or refer to the Service Information below.

ACTION:

Should a customer express this concern, follow the Workshop Procedure below.

PARTS:**NOTE:**

* - an allowance \$1.87 (or local equivalent) has been provided to cover the cost of the 2 locally sourced exhaust mounting rubber O-rings (10mm internal diameter). Claim using Sundry Code 'ZZZ001'.

PART NUMBER	DESCRIPTION	QUANTITY
JDE39467	Turbocharger assembly	1
JDE38503	Turbocharger to exhaust manifold gasket	1
C2C41707	Exhaust isolator system rubber	1

PART NUMBER	DESCRIPTION	QUANTITY
AJ813362	Oil supply tube sealing washers	4
JDE36824	Oil drain tube upper O-ring	1
JDE36825	Oil drain tube lower O-ring	1
T2H11760	Turbocharger to diesel particulate filter gasket	1
T4N15214	Exhaust Gas Recirculation (EGR) to turbocharger O-ring	1
AJ813344	EGR cooler to valve gasket	1

TOOLS:



E179225

Jaguar Land Rover-approved diagnostic tool with latest SDD Software Management Pack



E192494

Jaguar Land Rover-approved Midtronics battery power supply



E201918

Inline Diagnostic Unit 2 (IDU2)



E205520

Noise, vibration and harshness unit

WARRANTY:

NOTES:

- Repair procedures are under constant review, and therefore times are subject to change; those quoted here must be taken as guidance only. Always refer to JLR claims submission system to obtain the latest repair time.
- The JLR Claims Submission System requires the use of causal part numbers. Labor only claims must show the causal part number with a quantity of zero.

DESCRIPTION	SRO	TIME (HOURS)	CONDITION CODE	CAUSAL PART
Turbocharger - Noise, Vibration and Harshness - Application	86.98.46	0.2	42	JDE36863
Install a new exhaust mounting rubber	30.20.02	0.2	42	C2C41707
Turbocharger - Renew - F-PACE (X761)	18.50.32	1.2	42	JDE36863

 **NOTE:**

Normal Warranty procedures apply.

SERVICE INFORMATION:

1

 **NOTE:**

This issue affects only vehicles with an engine serial number up to and including **151001W0302**. Use the Jaguar Land Rover (JLR) claims submission system to obtain the engine serial number or go to Step 1.

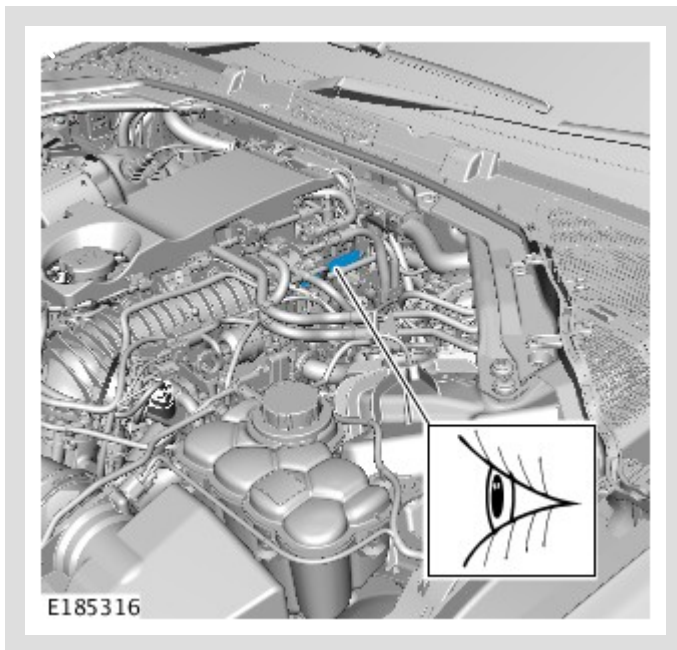

Locate and record the engine serial number.

- If the engine serial number is higher than **151002W0302**, do not continue with this Technical Bulletin.
- If the engine serial number is **151001W0302** or lower, go to the Workshop Procedure below.

WORKSHOP PROCEDURE:

WARNING:

Observe due care when working near a hot exhaust system.

1

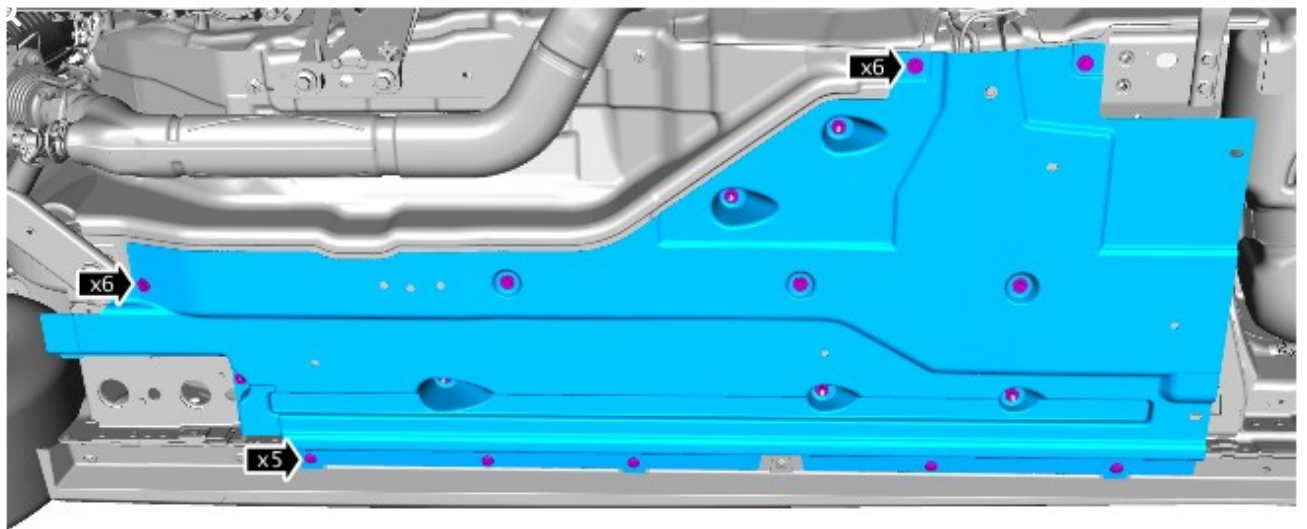

E171834

Remove the right undershield.

2

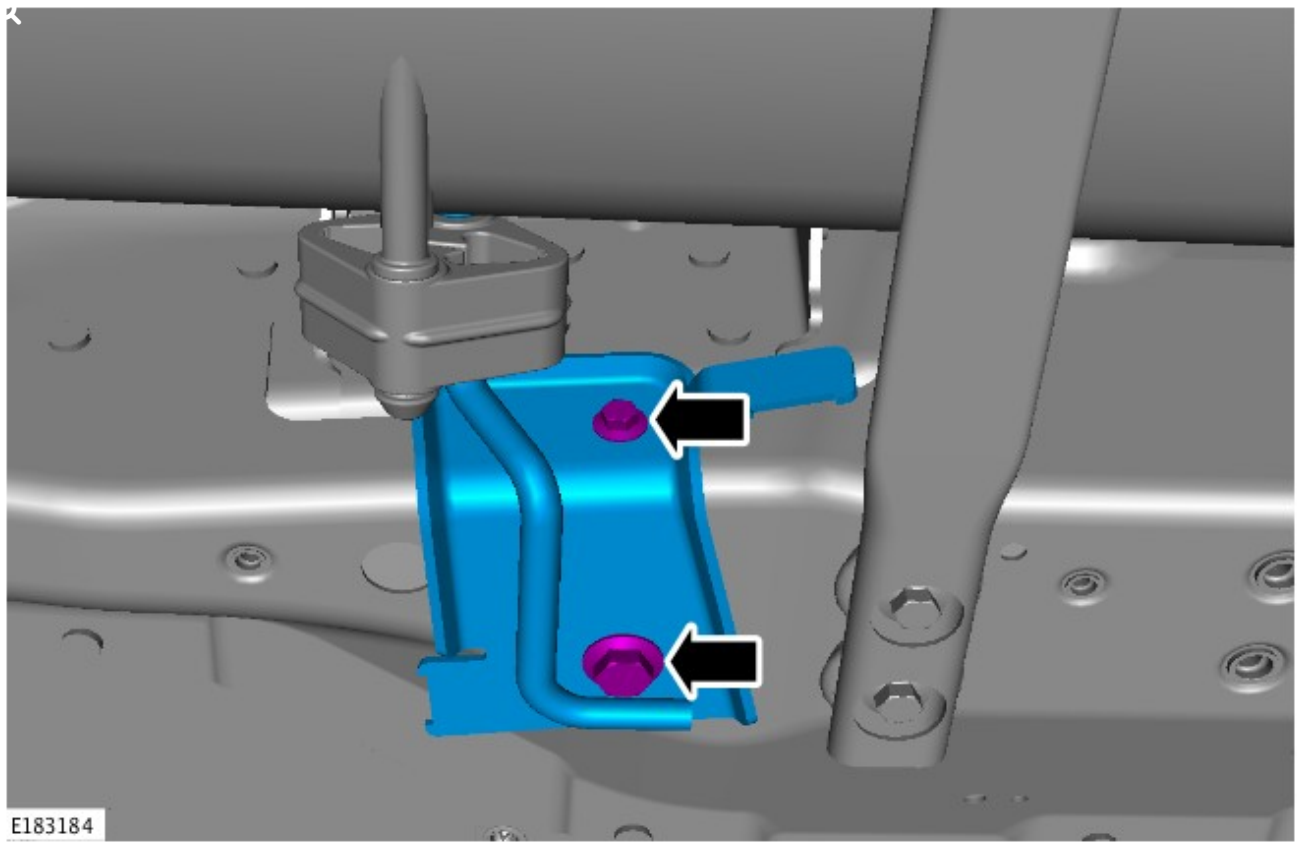

E183184

Remove the 2 exhaust system mounting rubber bracket retaining bolts.

3

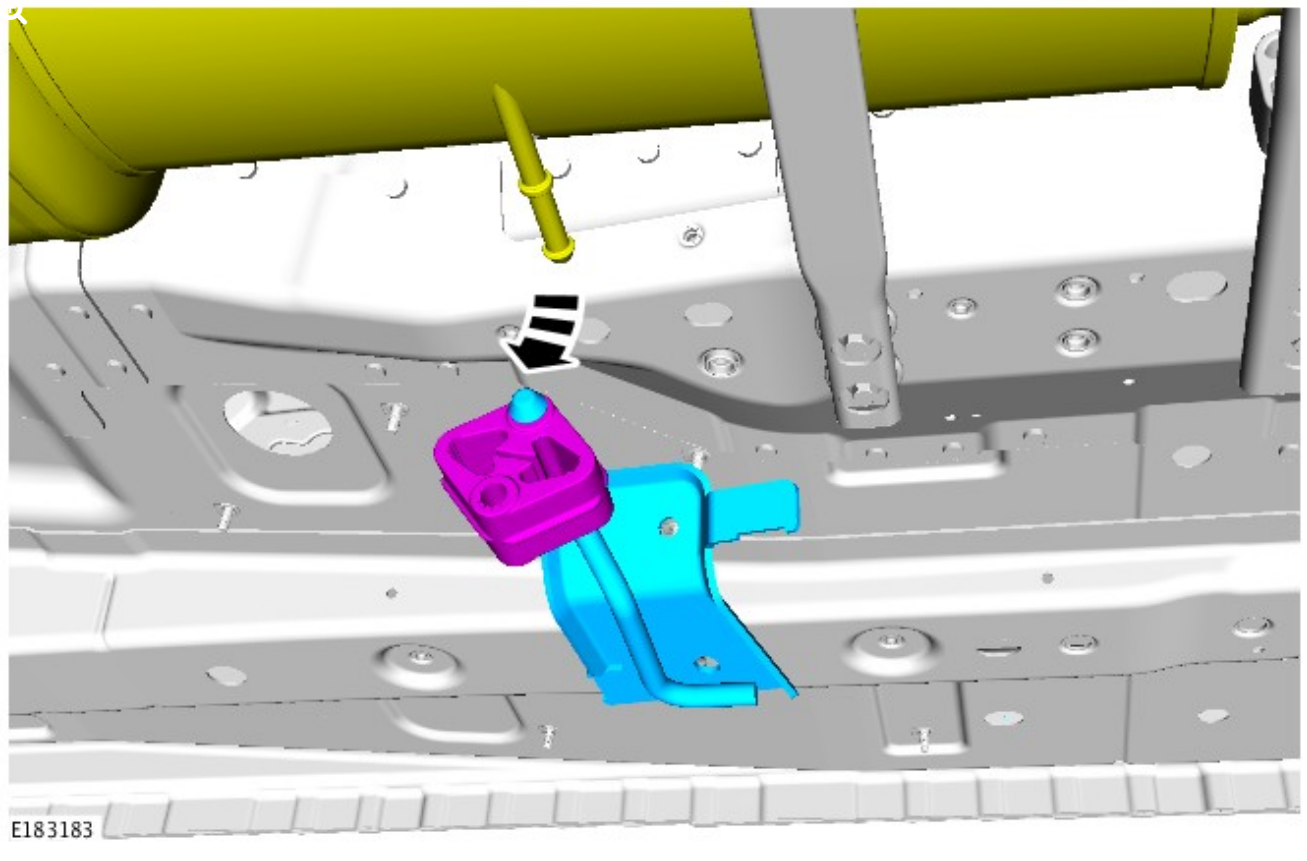

Remove the exhaust hanger bracket and exhaust mounting rubber from the exhaust system.

4

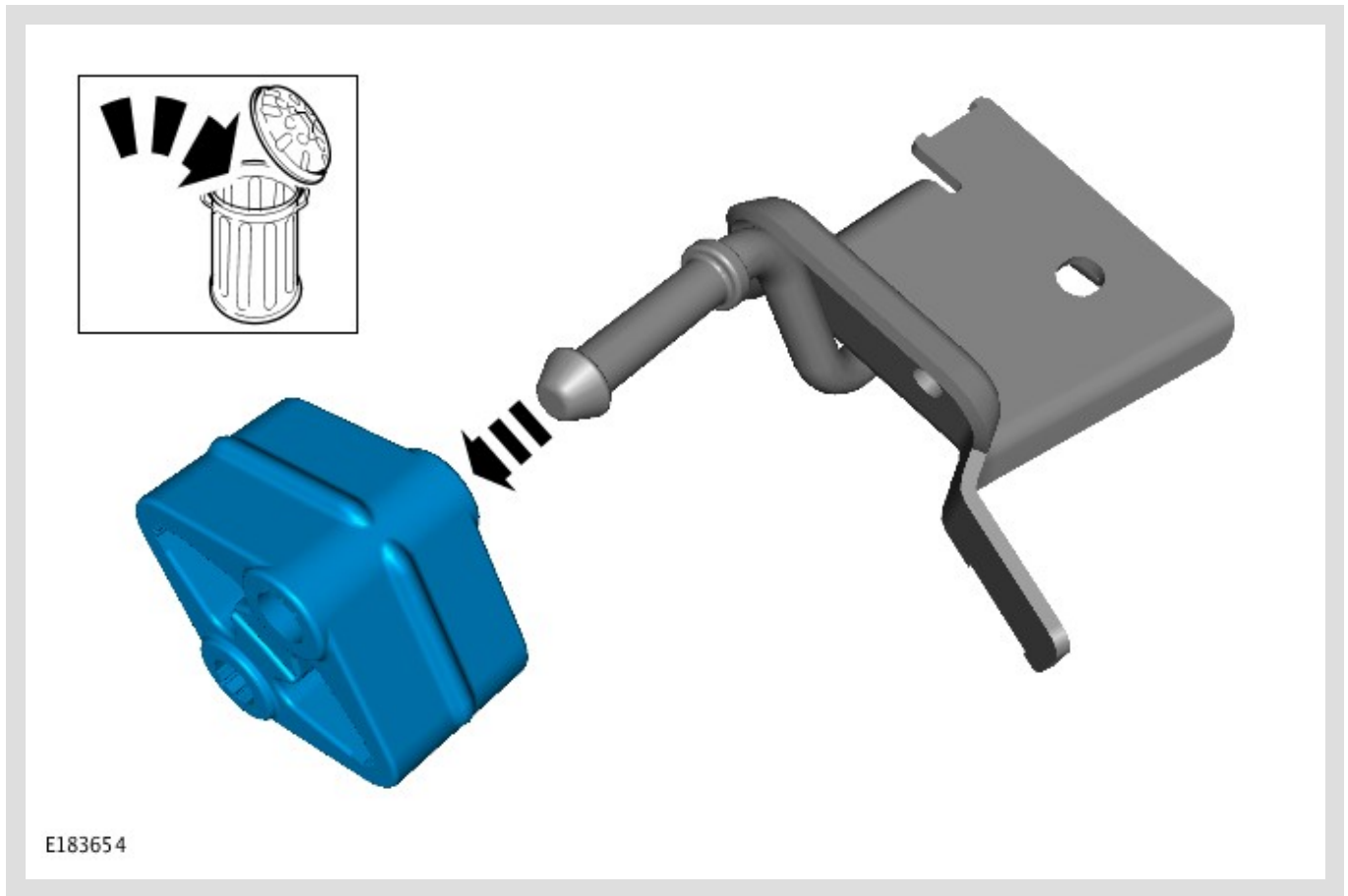

Remove and discard the exhaust mounting rubber from the exhaust hanger.

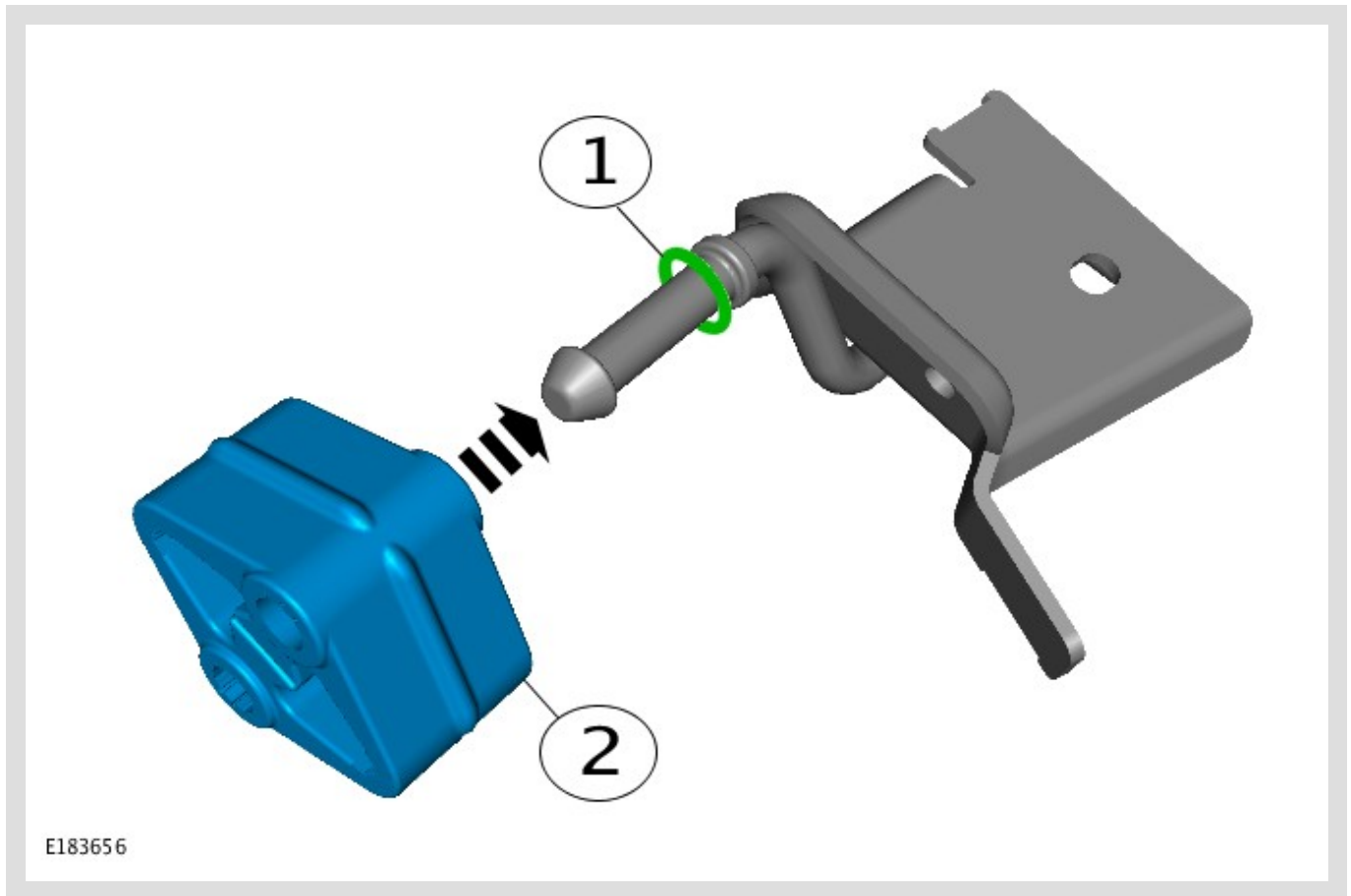

Install 1 locally sourced, 10mm internal diameter rubber O-ring onto the exhaust mounting rubber bracket **(1)**.

- Install the exhaust mounting rubber **(2)**.

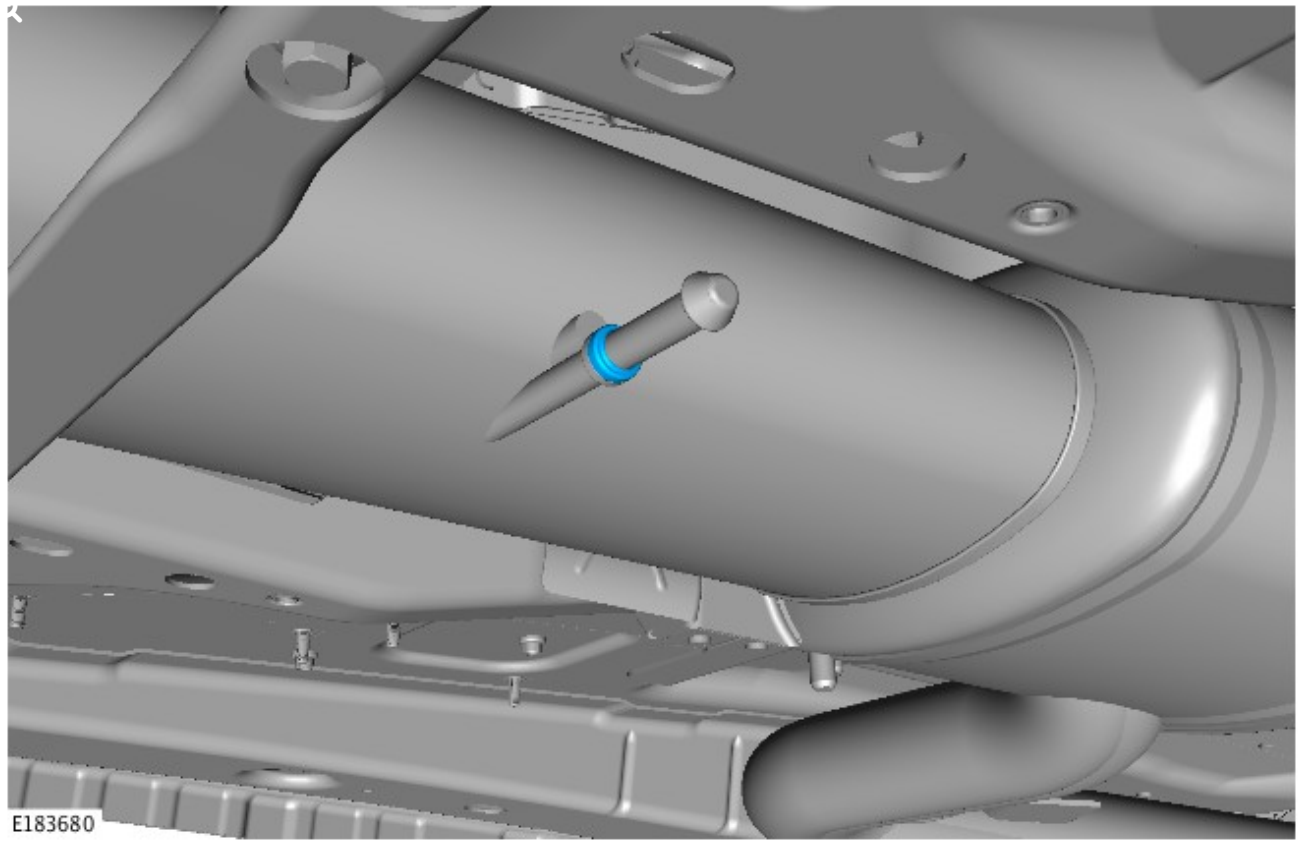

Install 1 locally sourced, 10mm internal diameter rubber O-ring onto the exhaust system.

7

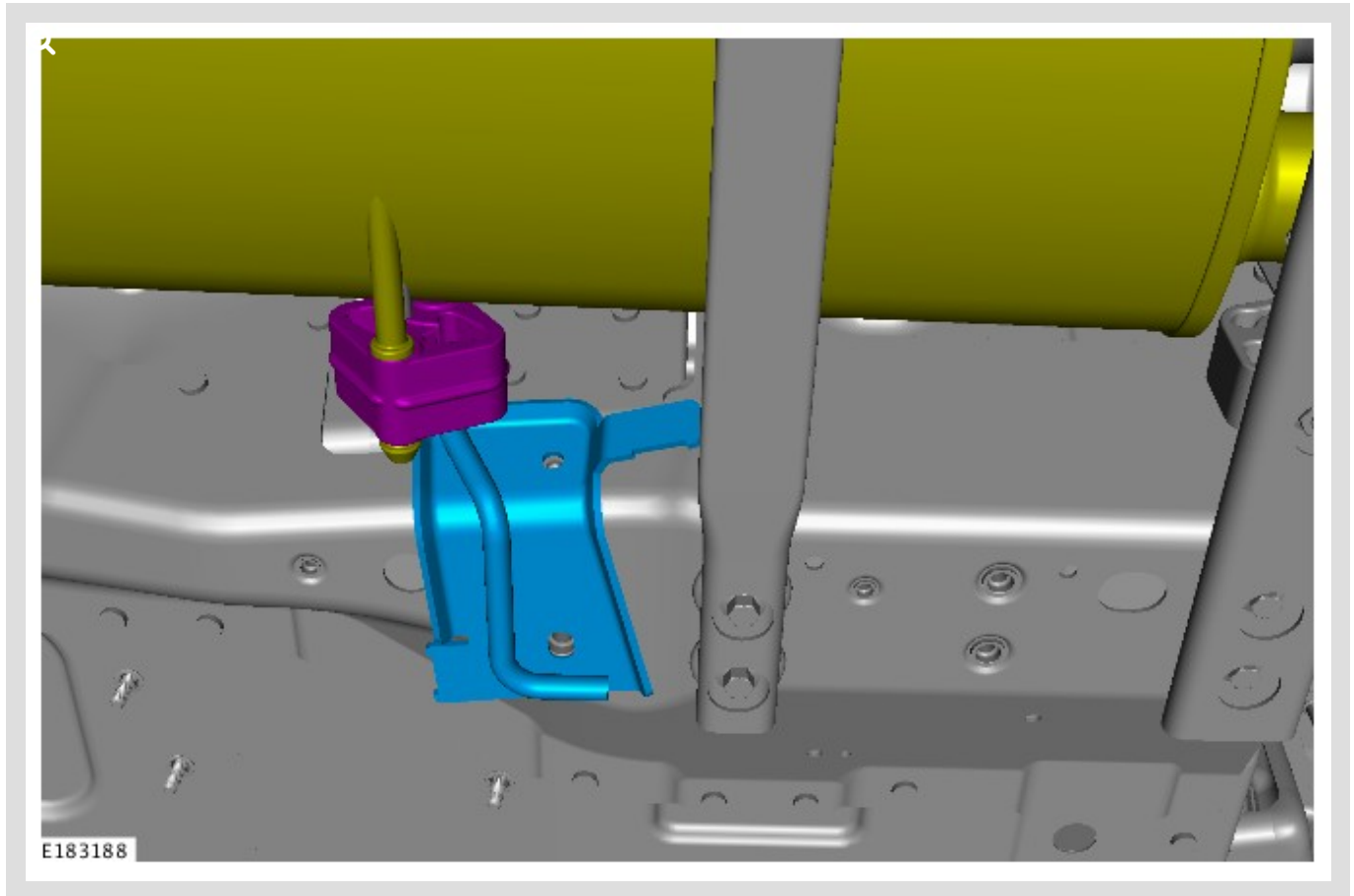

Install the exhaust hanger bracket and the new exhaust mounting rubber to the exhaust system.

8

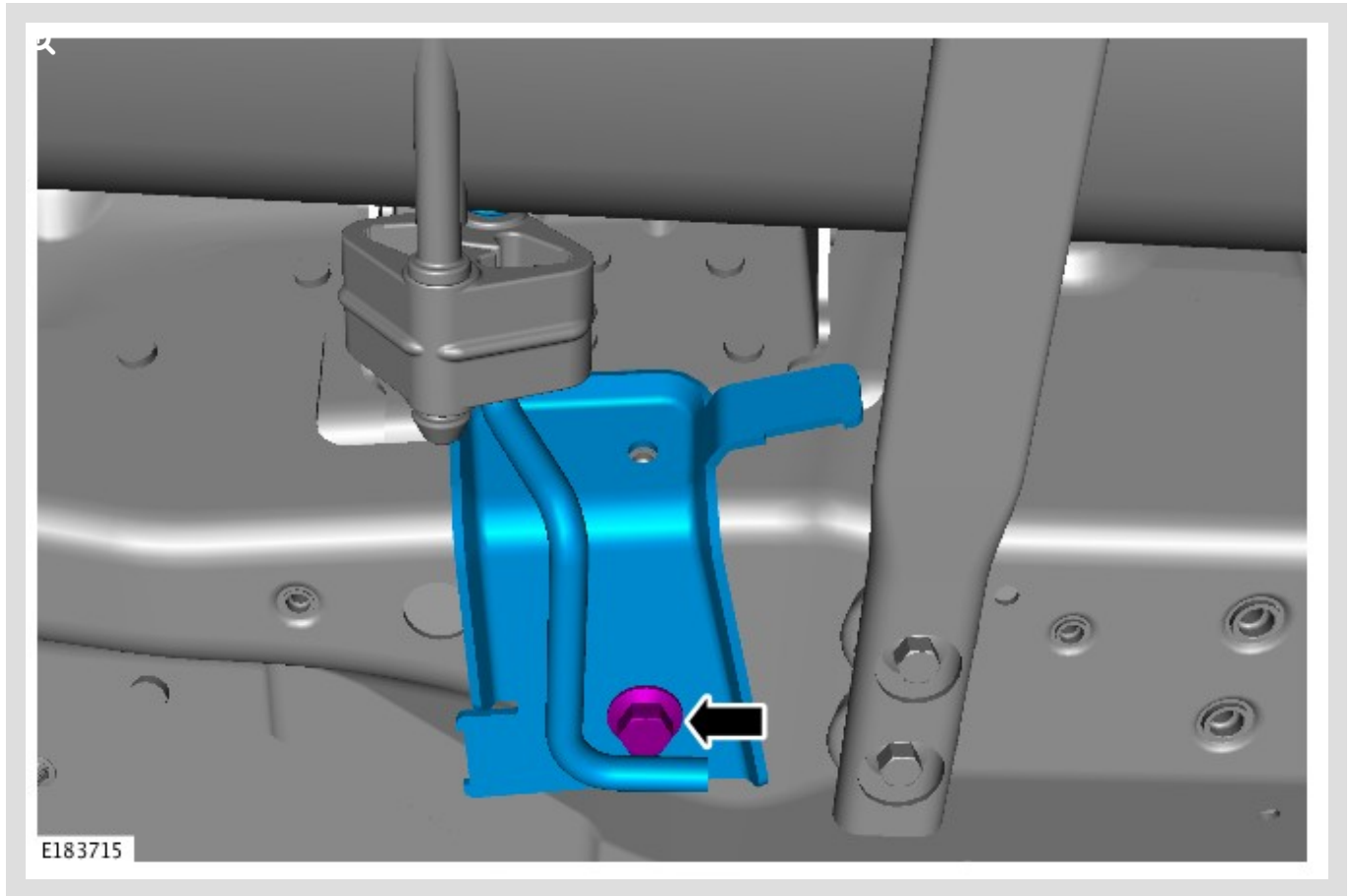

Install the exhaust system hanger bracket retaining bolt.

- Torque: **26 Nm.**

9

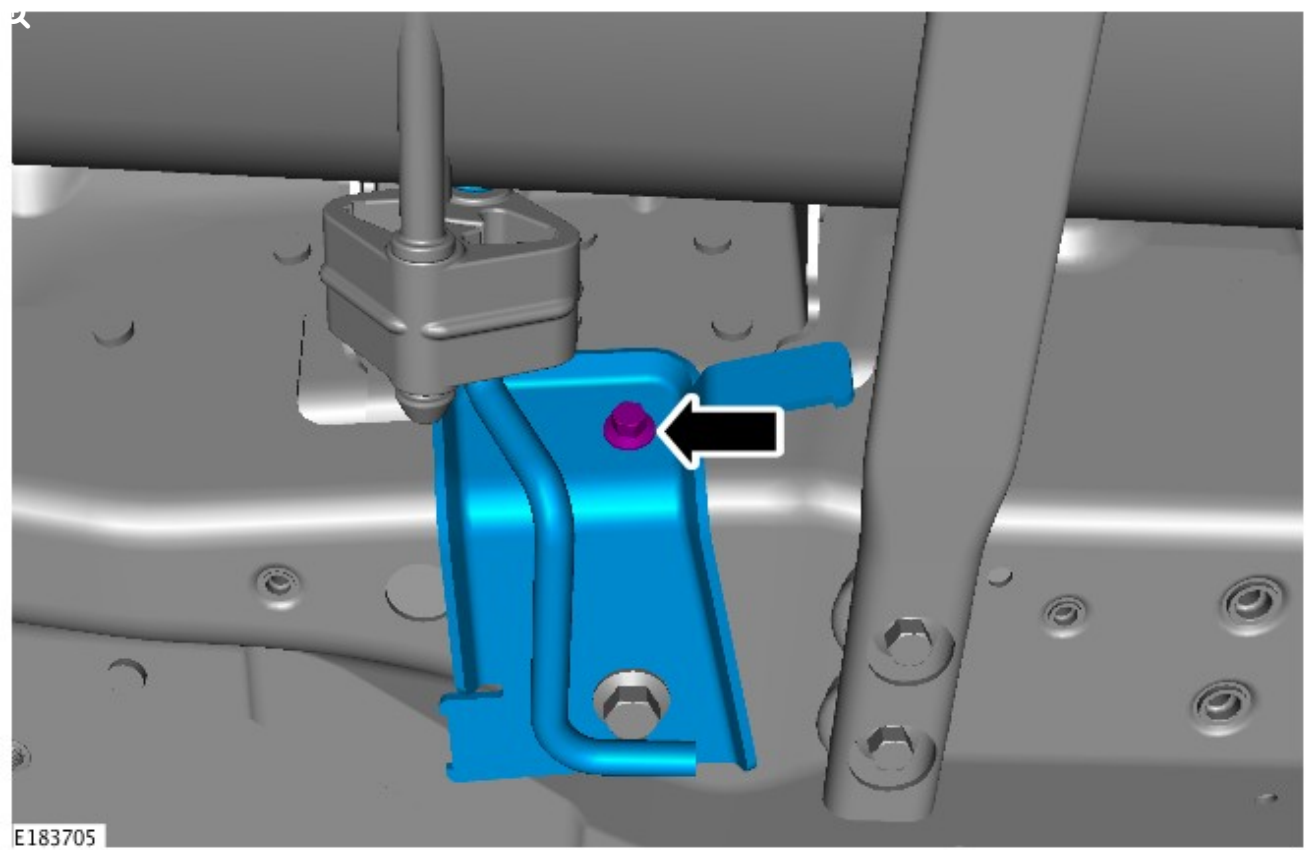

Install the exhaust hanger bracket retaining bolt.

- Torque: **10 Nm.**

10

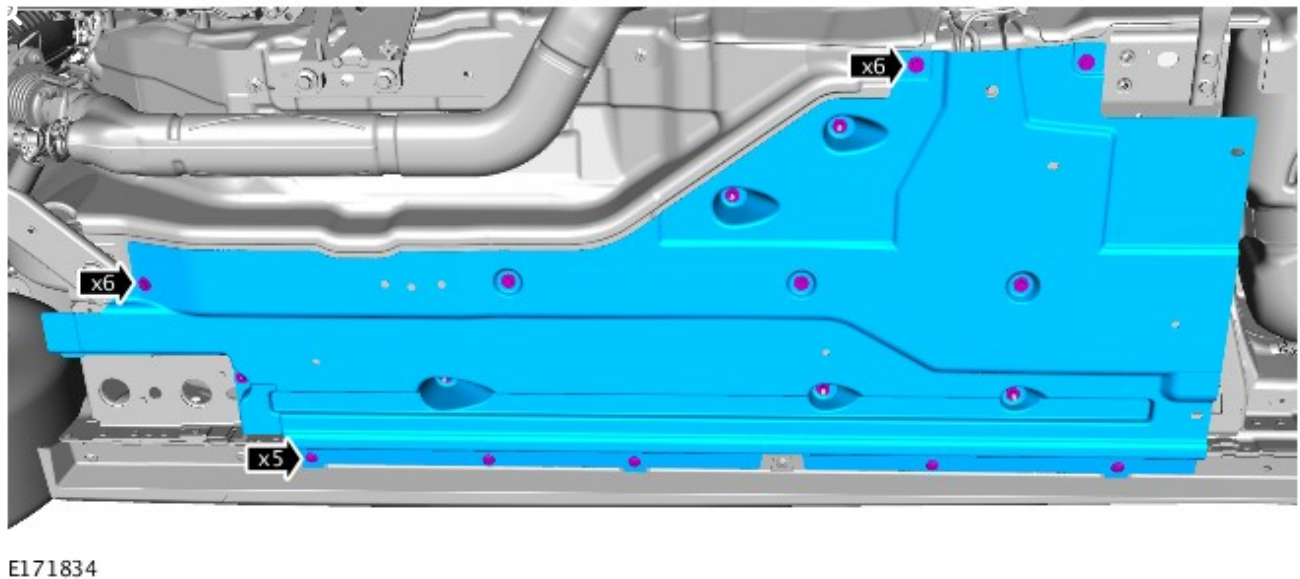

Install the right undershield.

11 Road test the vehicle to verify the turbocharger whine/whistle noise is reduced.

- If the turbocharger whine/whistle is reduced, **do not** continue with this Technical Bulletin.
 - Return the vehicle to the customer.
- If the turbocharger whine/whistle noise is not reduced, go to the Diagnostic Procedure below.

DIAGNOSTIC PROCEDURE:

CAUTIONS:

- A Jaguar Land Rover-approved Midtronics battery power supply must be connected to the vehicle startup battery during diagnosis / module programming.
- All ignition ON/OFF requests must be carried out. Failure to perform these steps may cause damage to control modules in the vehicle.

1

NOTE:

The Jaguar Land Rover-approved diagnostic tool must be loaded with SDD152.04 Software Management Pack v288 (or later).

Connect the Jaguar Land Rover-approved diagnostic tool to the vehicle and begin a new session.

2 Follow all on-screen instructions, allowing the diagnostic tool to read the VIN, identify the vehicle, and initiating the data collect sequence.

3 If the hyperlink is not available:

- 1 Select **Diagnosis** from the Session Type screen.
- 2 Select the **Selected Symptoms** tab.
- 3 Select **Powertrain - Engine system - Engine performance**
- 4 Select **continue**.

5 Select the **Recommendations** tab.

6 Select **Run** to perform the '**Special applications - Noise, vibration and harshness sensor diagnostic test - Turbocharger**' option.

4 Follow all on-screen instructions until the application completes successfully.

1 When all tasks are complete, go to the next Step.

5 Exit the current session.

1 Select the **Session** tab.

2 Select the **Close Session** option.

6 Disconnect the diagnostic tool and battery power supply from the vehicle.

7

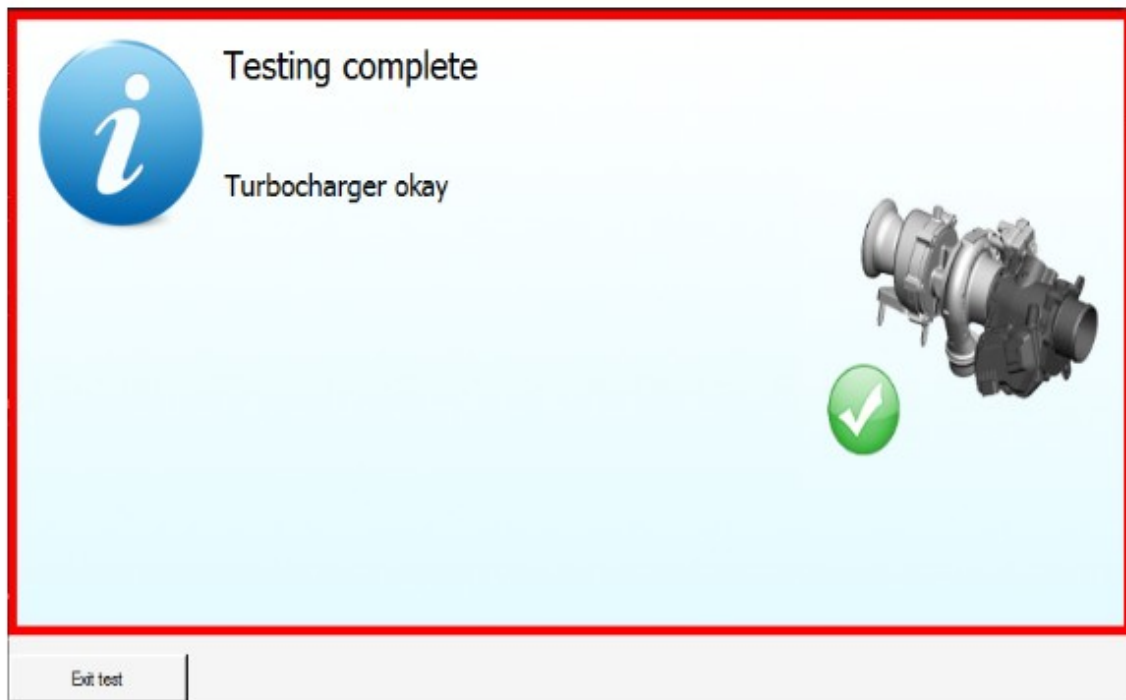

E203627

Example of a 'pass'.

- If the turbocharger does pass (✓) the diagnostic test, carry out further diagnostics (see TOPIx Workshop Manual section 303-04E: Fuel Charging and Controls -

Turbocharger - INGENIUM I4 2.0L Diesel - Diagnosis and Testing - Turbocharger .

8

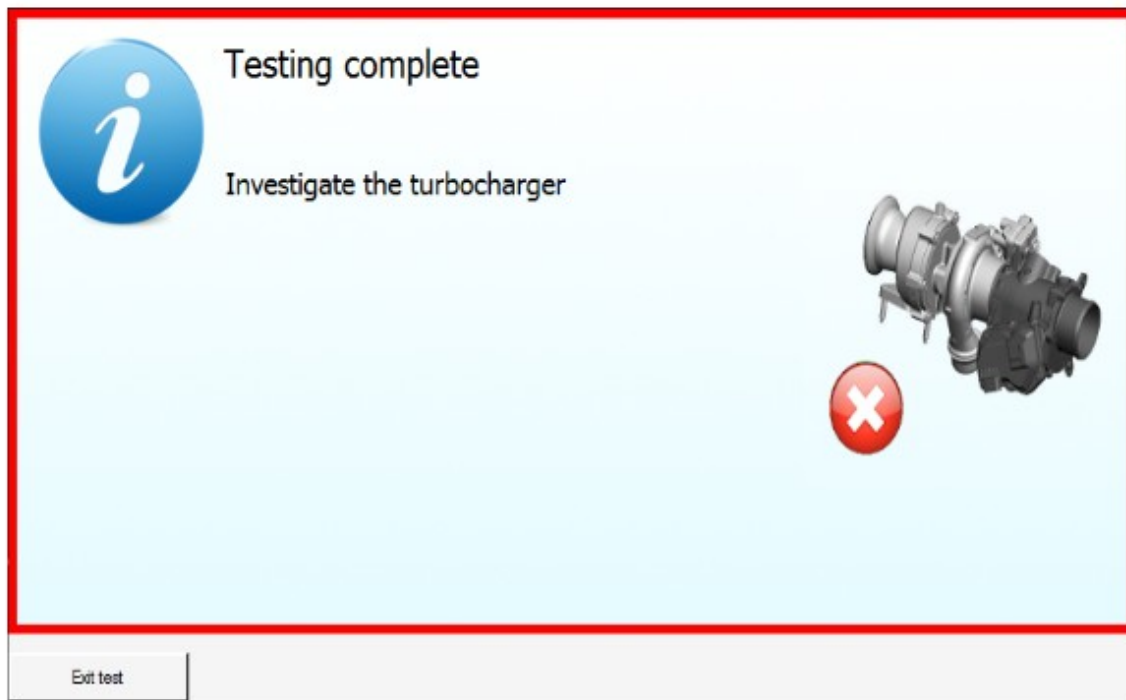

E203628

Example of a 'fail'.

- If the turbocharger does not pass [fails - (X)] the diagnostic test, replace the turbocharger (see TOPIx Workshop Manual section 303-04E: Fuel Charging and Controls - Turbocharger - INGENIUM I4 2.0L Diesel - Removal and Installation - Turbocharger).